

groov EPIC Chassis

Features

- > Secure mounting for power supply and processor, with or without *groov*® I/O modules
- > Mount on a panel or 35 mm DIN-rail
- > Modules pivot into place, plug into a module connector, and lock onto the chassis with a single screw
- > Processor and power supply interlock and are secured with a screw
- > UL Hazardous Locations approved and ATEX compliant



GRV-EPIC-CHS4

DESCRIPTION

All *groov* EPIC® I/O mounting chassis are designed to hold an intelligent *groov* EPIC processor and power supply, with models available that can also hold 0, 4, 8, or 16 *groov* I/O modules.

The **GRV-EPIC-CHS4**, **GRV-EPIC-CHS8**, and **GRV-EPIC-CHS16** can hold a mix of *groov* analog, discrete, and serial I/O modules, because all modules have the same footprint. Analog and discrete modules can be placed in any module position on the chassis. Serial modules can be placed in any of the first four positions and are directly connected to the *groov* EPIC processor via the bus on the chassis.

Field devices are wired directly to the top-mounted connectors on the modules. The module and chassis design allows each module to pivot into a specific mounting position on the chassis.

The **GRV-EPIC-CHS0** mounts the processor and power supply only (no I/O modules) and is ideal for applications where I/O is not needed and cabinet space is at a premium.

A Complete I/O Unit Where You Need It

With a GRV-EPIC-CHS4, GRV-EPIC-CHS8, or GRV-EPIC-CHS16, you can have a powerful I/O unit wherever you need it. From small applications in a limited physical space, to larger applications with complex requirements, the three models are designed to meet a large range of application requirements and physical space limitations.

Beyond a PLC – Processing Power at the Edge

With a GRV-EPIC-CHS0, you can put a *groov* EPIC processor (GRV-EPIC-PR1) in tough, industrial locations where typical computers or networking equipment may not be able to operate. The processor can provide the computing power and networking connectivity you need to modernize and extend your applications and systems. To learn more about the capabilities of the *groov* EPIC processor, see [groov EPIC Processor Data Sheet](#) (form 2245).

Agency Approvals and Compliance

All *groov* power supplies, voltage converters, pass-through power adapters, I/O modules, and processors are UL/cUL listed and compliant with the ATEX, Low Voltage, and EMC CE directives. Each module is factory tested twice before shipment and most modules are guaranteed for life.



Part Numbers

Part	Description
GRV-EPIC-CHS0	Processor and power supply only mounting chassis
GRV-EPIC-CHS4	4-module analog/discrete/serial mounting chassis
GRV-EPIC-CHS8	8-module analog/discrete/serial mounting chassis
GRV-EPIC-CHS16	16-module analog/discrete/serial mounting chassis

SPECIFICATIONS

All specifications assume the following:

- The air temperature 1 inch below the bottom of the chassis vents does not exceed 70 °C.
- The vents are unobstructed.
- The chassis is mounted in a horizontal orientation with the back of the unit mounted on a vertical surface.

For a diagram that shows the bottom of the chassis, see “Overall Dimensions with Power Supply, Processor, and Modules Mounted” on page 4. For a diagram that shows the chassis in standard orientation, see “Orientation and Clearances” on page 5.

Specification	GRV-EPIC-CHS16	GRV-EPIC-CHS8	GRV-EPIC-CHS4	GRV-EPIC-CHS0
Number of module slots	16	8	4	0
Maximum Power Rating	60 W with GRV-EPIC-PSAC 50 W with GRV EPIC PSDC 108 W with GRV-EPIC-PSPT			
Temperature (operating)	-20 °C to +70 °C			
Temperature (storage)	-40 °C to +85 °C			
Humidity (non-condensing)	5–95% RH			
Agency Approvals	UL/cUL(Class 1 Div. 2), CE, ATEX(Category 3, Zone 2), RoHS, DFARS; CB Scheme			
Warranty	30 months			

DIMENSIONS: GRV-EPIC-CHS0, GRV-EPIC-CHS4, GRV-EPIC-CHS8, AND GRV-EPIC-CHS16

If you want to import these dimensions into an AutoCAD software system, go to the Opto 22 website and download [CAD Drawings: groov EPIC chassis](#).

Part Number	Description	Width (inches)	Width (mm)	Length (inches)	Length (mm)	Depth (inches)	Depth (mm)
GRV-EPIC-CHS0	0-module chassis	5.36	136.2	3.54	90.0	2.95	101.1
GRV-EPIC-CHS4	4-module chassis	5.36	136.2	6.81	173.0	3.98	101.1
GRV-EPIC-CHS8	8-module chassis	5.36	136.2	10.18	258.5	3.98	101.1
GRV-EPIC-CHS16	16-module chassis	5.36	136.2	16.91	429.6	3.98	101.1

Depth and Length Dimensions

These diagrams show the bottom view of the chassis.

GRV-EPIC-CHS0

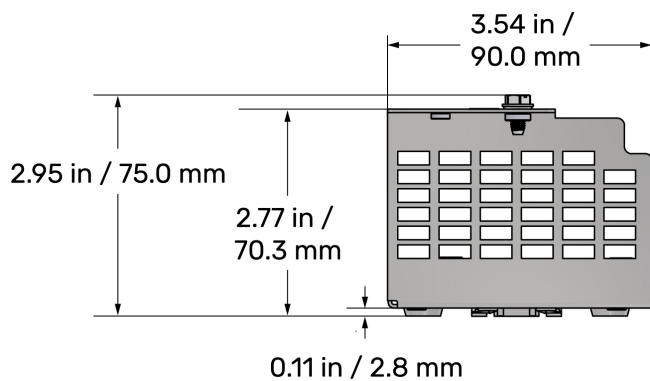

GRV-EPIC-CHS4

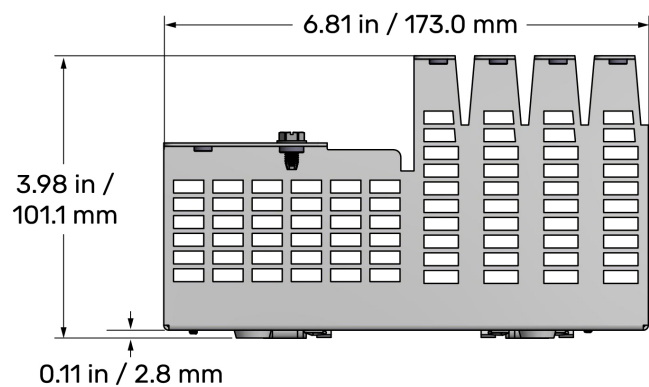

GRV-EPIC-CHS8

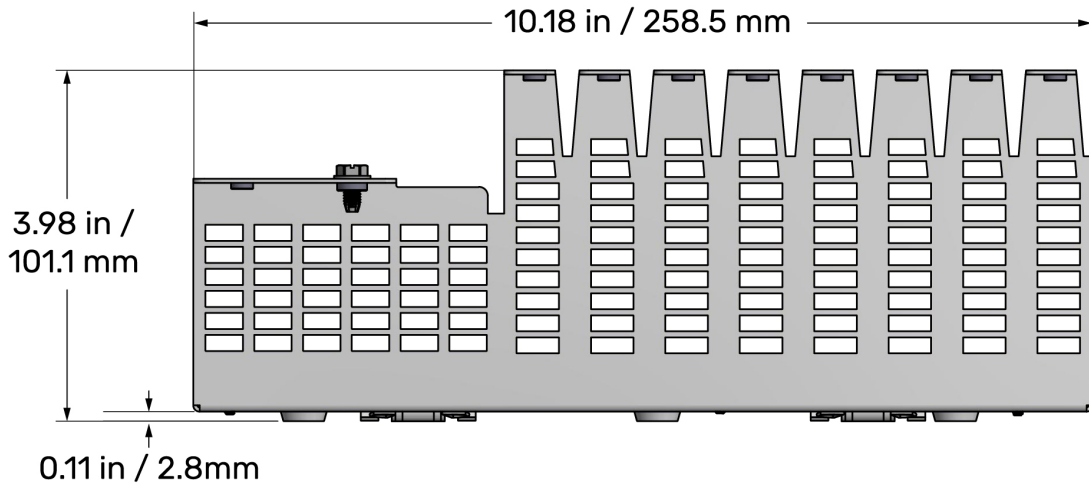

GRV-EPIC-CHS16

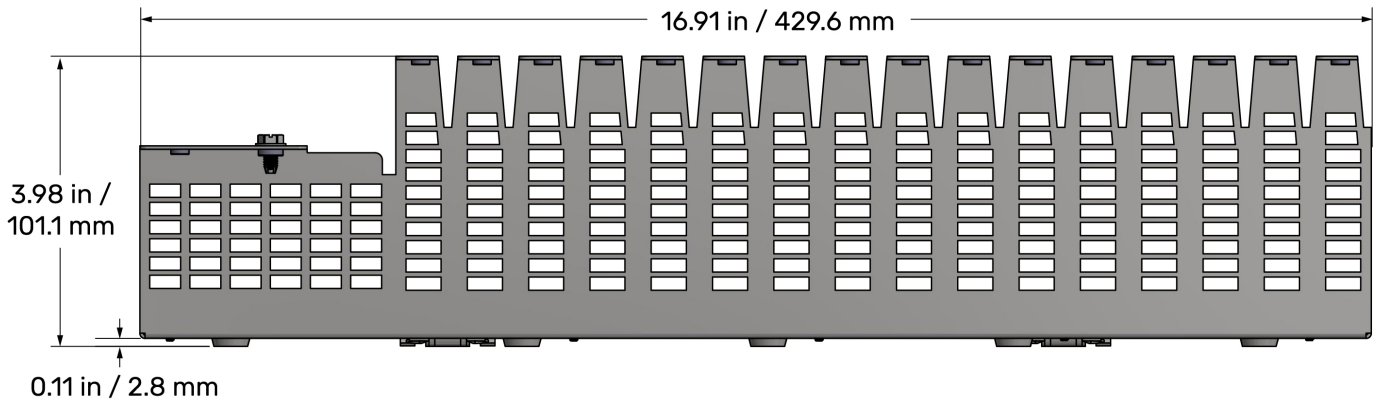

Overall Dimensions with Power Supply, Processor, and Modules Mounted

The following diagrams show the dimensions of a 16-module chassis with a power supply, processor, and 16 modules mounted on it, with the touchscreen open in a two different positions. The DIN rail shown is a standard 35 mm DIN rail (not sold by Opto 22). When you are determining a location for the chassis, ensure you comply with the orientation and clearances indicated in "Orientation and Clearances" on page 5.

End View

The dimensions shown in the diagram to the right show the touchscreen in two positions:

- Open. Those are the dimensions at the top of the diagram.
- Closed. Those are the dimensions at the bottom of the diagram.

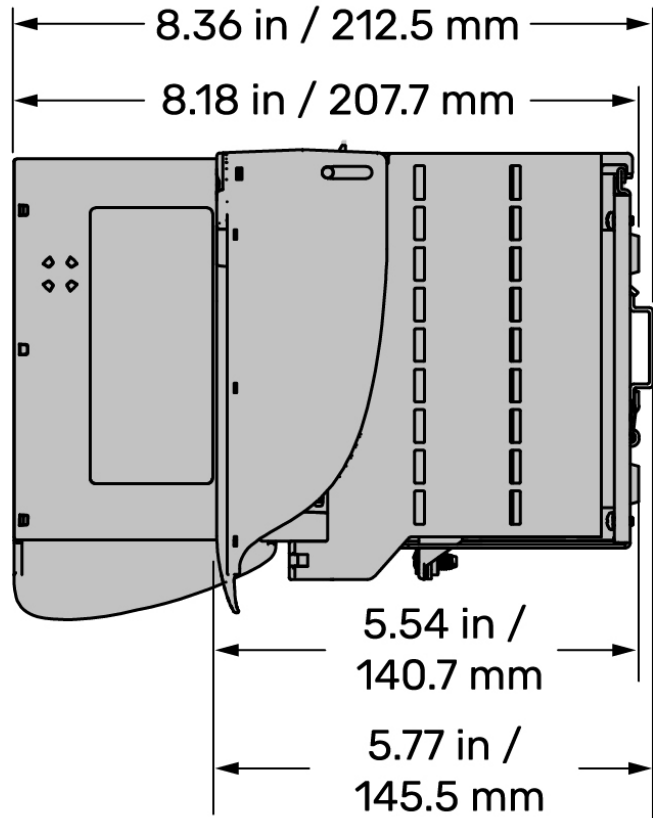

Back View

The dimensions shown in the following diagram indicate the distance between the DIN rail (if used) and the edges of the chassis and the edges of the unit (if modules are mounted to the chassis). The view shows the touchscreen open upright, perpendicular to the view.

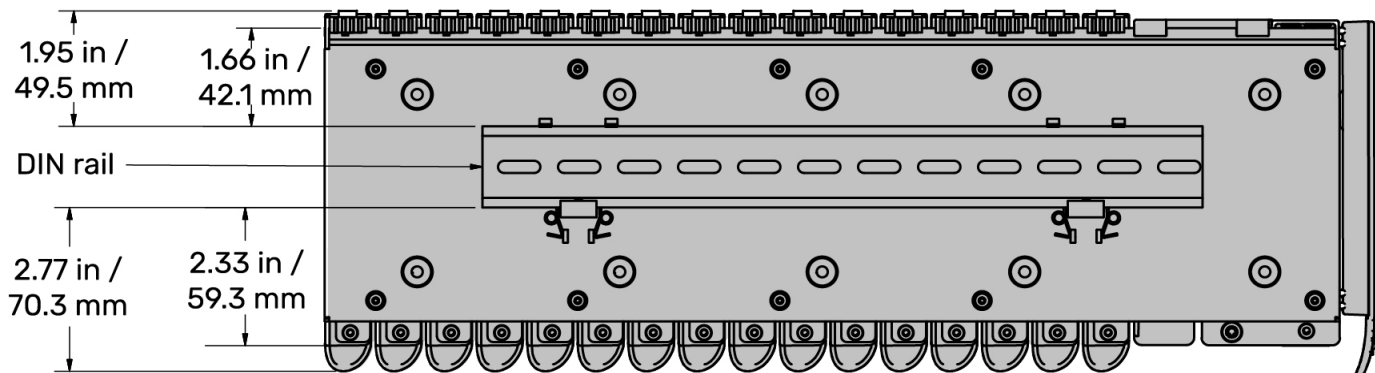

Bottom View

The dimensions in the following diagram show the display open in two positions: upright and out to its fullest extension.

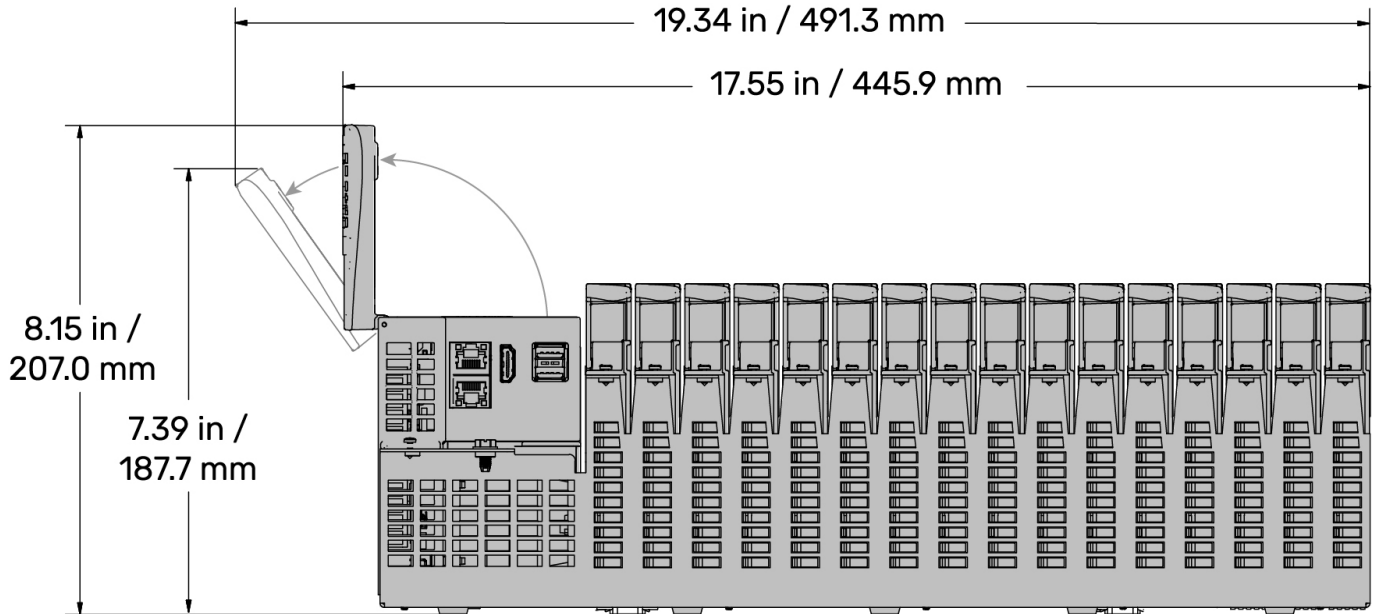

ORIENTATION AND CLEARANCES

The diagrams in this section show the orientation and the clearances recommended to ensure compliance with the specifications.

The diagram below shows a chassis (with modules, power supply, and *groov* EPIC processor mounted on the chassis) with arrows indicating a minimum 2 inch clearance all around the unit.

The diagram below shows the chassis mounted in a cabinet in a horizontal orientation.

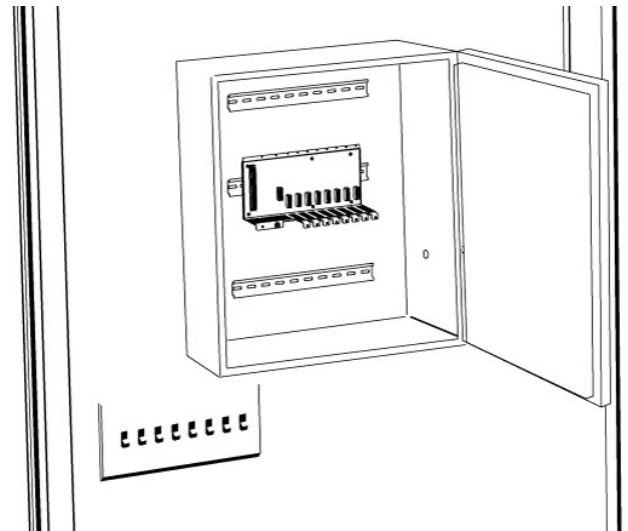
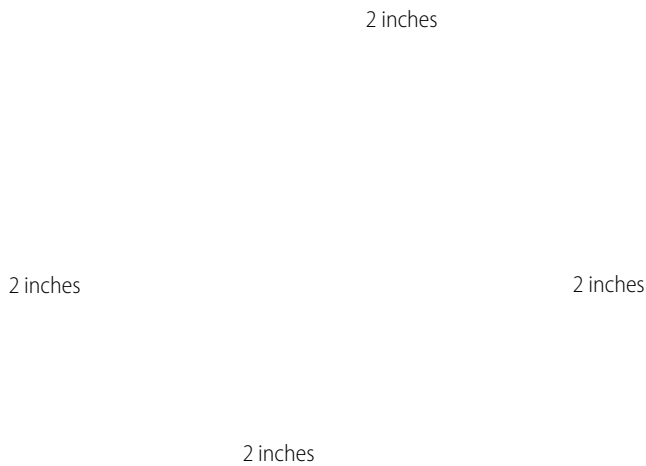

ASSEMBLING AND MOUNTING

Before assembling and mounting your equipment, make sure you have the necessary clearances to ensure good ventilation, and that the area where you will be installing the equipment does not exceed the specifications listed in “Specifications” on page 2. Check the following:

- Ensure that there is a minimum of 2 inches clearance on the top, bottom, each side, and front of the rack, after the processor, power supply, and modules are mounted.
- Ensure that the vents at the bottom of the chassis are not obstructed.
- When you choose a mounting location, ensure that the location complies with the orientation and clearances specified in “Orientation and Clearances” on page 5.

Mounting on a DIN Rail

The chassis is built with DIN rail adapters for use on 35 mm DIN rail. No additional assembly is required.

Mount the empty chassis to the DIN rail before installing the *groov* EPIC power supply, processor, or I/O modules.

To mount the chassis to a DIN rail, follow these steps:

1. Hold the chassis so that the module connector numbers are facing right side up.
2. Hold the chassis at an angle such that the top of the DIN rail adapter is away from the DIN rail and the bottom of the DIN rail adapter can slide behind the bottom lip of the DIN rail.
3. Push the bottom part of the chassis upward, making sure that you feel the clip catch on to the rail, and simultaneously push the top half of the chassis toward the DIN rail until the top of the DIN rail adapter engages the top lip of the DIN rail.

Before you release the chassis, verify that the top and bottom of the DIN rail adapters have engaged the DIN rail.

4. For all chassis models, mount the power supply and the processor. For the chassis models that also hold *groov* I/O modules, mount the modules onto the chassis.

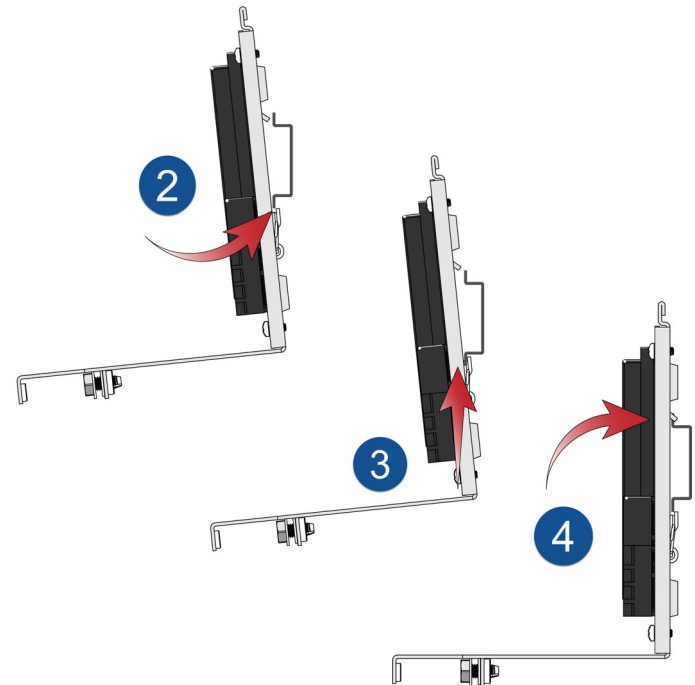

Mounting on a Panel

Using Chassis as Template

Use this method if you have the chassis on hand to use as a template.

1. Review the mounting hole dimensions on the next page and the dimensional drawings in previous pages to determine required product and option clearances.
2. Opto 22 ships the backplane attached to the chassis, so remove the backplane to gain access to the chassis mounting holes.
3. Use the chassis as a template to mark holes.
4. After the chassis is securely mounted, attach the backplane with the retention screws provided.

Alternate Method: Prefabrication of Panels

If you do not have the chassis on hand, review the diagrams on the next page to determine mounting hole positions.

Mounting Hole Dimensions

The following diagrams show the length measurements from the edges of the chassis to the center positions of the mounting holes. When you install the chassis, use pan head screws of up to 10-32 in size.

GRV-EPIC-CHS0

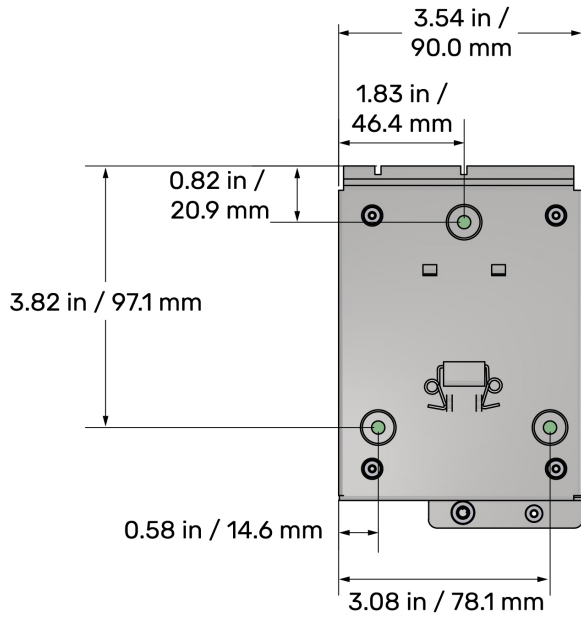

GRV-EPIC-CHS4

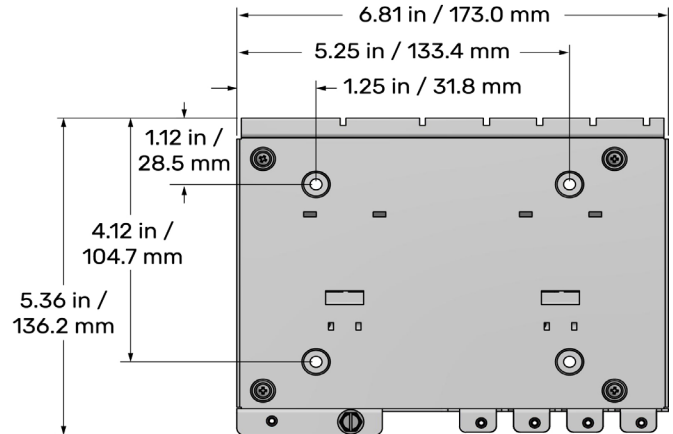

GRV-EPIC-CHS8

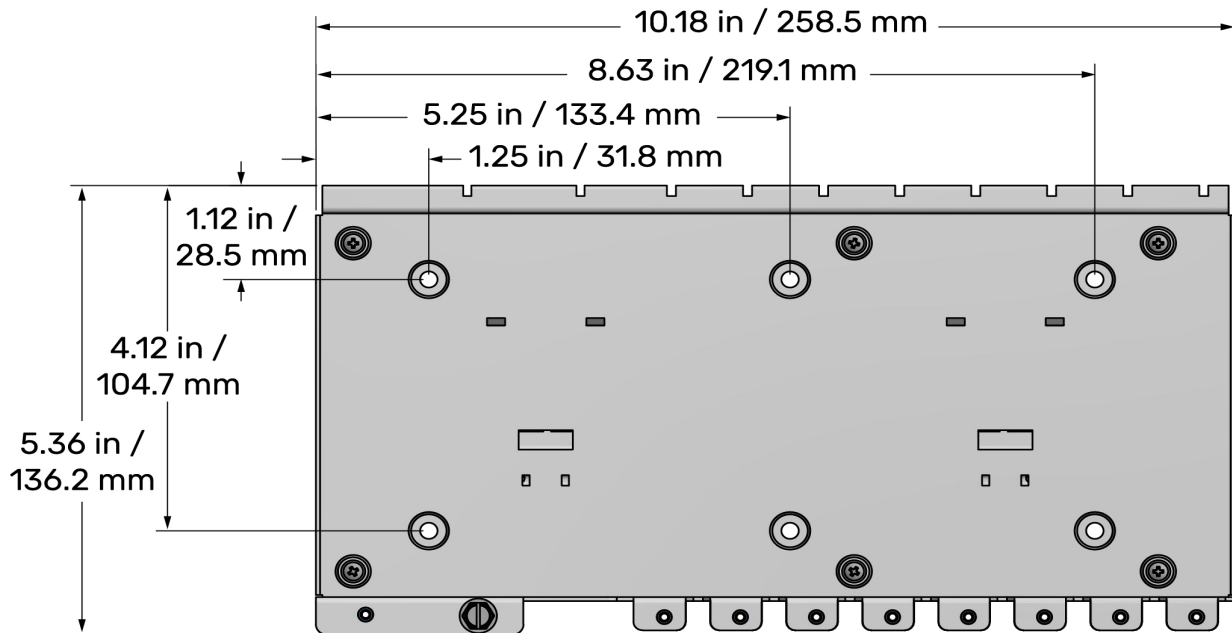

GRV-EPIC-CHS16

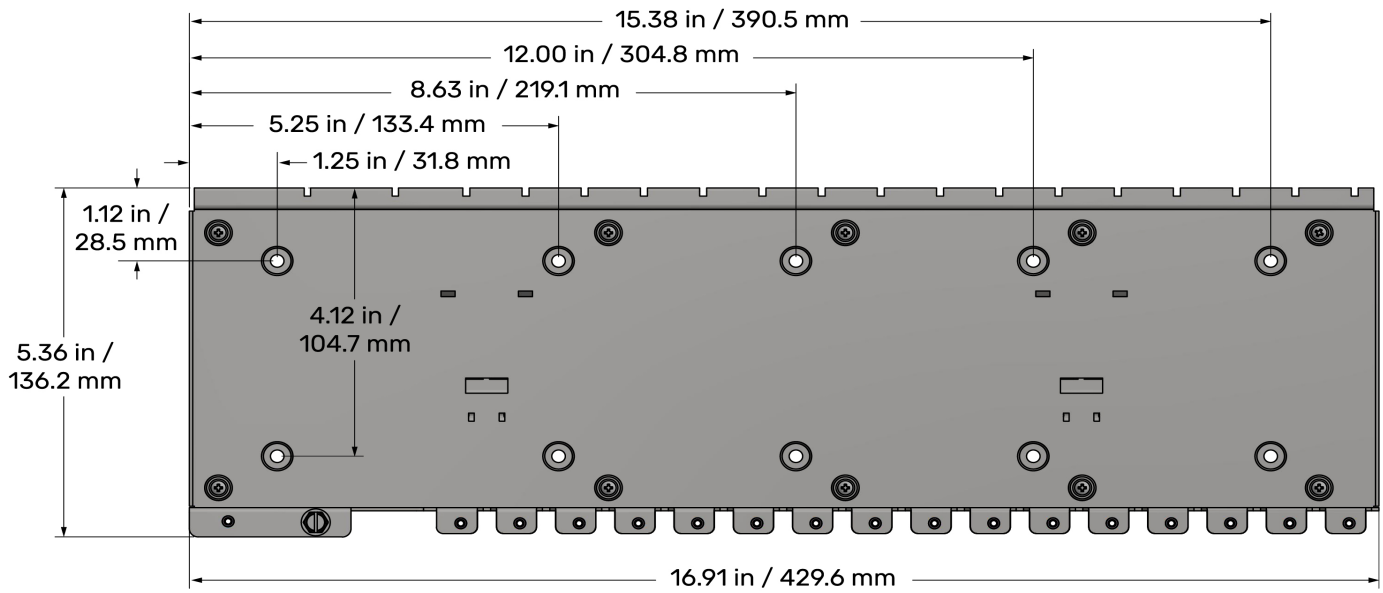

PRODUCTS

Opto 22 develops and manufactures reliable, easy-to-use, open standards-based hardware and software products.

Industrial automation, process control, building automation, industrial refrigeration, remote monitoring, data acquisition, and industrial internet of things (IIoT) applications worldwide all rely on Opto 22.

groov EPIC® System

Opto 22's *groov* Edge Programmable Industrial Controller (EPIC) system is the culmination of over 40 years of experience in designing products for the automation industry.

groov EPIC gives you an industrially hardened system with guaranteed-for-life I/O, a flexible Linux®-based processor with gateway functions, and software that meets the needs of your automation and IIoT applications.

groov EPIC I/O

I/O provides the local connection to sensors and equipment. *groov* I/O offers up to 24 channels on each I/O module, with a spring-clamp terminal strip, integrated wireway, swing-away cover, and LEDs indicating module health and digital channel status.

groov I/O is hot swappable, UL Hazardous Locations approved, and ATEX compliant. Opto 22 I/O is so reliable, we guarantee it for life.

groov EPIC Processor

The heart of the system is the *groov* EPIC processor. It handles a wide range of digital, analog, and serial functions for data collection, remote monitoring, process control, and discrete and hybrid manufacturing.

In addition, the EPIC provides secure data communications among physical assets, control systems, software applications, online services, and more, both on premises and in the cloud.

Configuring and troubleshooting I/O and networking is easier with the EPIC's integrated high-resolution color touchscreen. Authorized users can manage the system locally on the touchscreen or on a monitor connected via the HDMI or USB ports.

groov EPIC Software

Software included in the *groov* EPIC controller:

- PAC Control engine to run PAC Control strategies and PAC Display projects
- CODESYS Runtime engine to run IEC61131-3 compliant programs built with CODESYS Development System

- Optional access to the Linux operating system through a secure shell (SSH) to download and run custom applications
- *groov* View for building your own device-independent HMI, viewable on the touchscreen, PCs, and mobile devices.
- Node-RED for creating simple logic flows from pre-built nodes
- Ignition Edge® from Inductive Automation®, with OPC-UA drivers to Allen-Bradley®, Siemens®, and other control systems, and MQTT/Sparkplug communications for efficient IIoT data transfer

Older products

From solid state relays (our first products) to world-famous G4 and SNAP I/O, to SNAP PAC controllers, older Opto 22 products are still supported and still doing the job at thousands of installations worldwide. You can count on us to give you the reliability and service you expect, now and in the future.

QUALITY

Founded in 1974, Opto 22 has established a worldwide reputation for high-quality products. All are made in the U.S.A. at our manufacturing facility in Temecula, California.

Because we test each product twice before it leaves our factory rather than testing a sample of each batch, we can afford to guarantee most solid-state relays and optically isolated I/O modules for life.



FREE PRODUCT SUPPORT

Opto 22's California-based Product Support Group offers free, comprehensive technical support for Opto 22 products from engineers with decades of training and experience. Support is available in English and Spanish by phone or email, Monday–Friday, 7 a.m. to 5 p.m. PST.

Support is always available on our website, including [free online training](#) at OptoU, how-to [videos](#), [user's guides](#), the Opto 22 KnowledgeBase, troubleshooting tips, and [OptoForums](#). In addition, instructor-led, hands-on [Premium Factory Training](#) is available at our Temecula, California headquarters, and you can [register online](#).

PURCHASING OPTO 22 PRODUCTS

Opto 22 products are sold directly and through a worldwide network of distributors, partners, and system integrators. For more information, contact Opto 22 headquarters at **800-321-6786** (toll-free in the U.S. and Canada) or **+1-951-695-3000**, or visit our website at www.opto22.com.