



ELECTRONICS, INC.
 44 FARRAND STREET
 BLOOMFIELD, NJ 07003
 (973) 748-5089
<http://www.nteinc.com>

NTE74LS26 Integrated Circuit TTL – Quad 2–Input High Voltage Positive NAND Gate

Description:

The NTE74LS26 is a quad 2–Input open–collector NAND gate in a 14–Lead plastic DIP type package featuring high–output voltage ratings for interfacing with low–threshold–voltage MOS logic circuits or other 12V systems. Although the output is rated to withstand 15V, the V_{CC} terminal is connected to the standard 5V source.

Absolute Maximum Ratings: (Note 1)

Supply Voltage, V_{CC} 7V
 DC Input Voltage, V_{IN} 7V
 Operating Temperature Range, T_A 0°C to +70°C
 Storage Temperature Range, T_{stg} –65°C to +150°C

Note 1. Unless otherwise specified, all voltages are referenced to GND.

Recommended Operating Conditions:

Parameter	Symbol	Min	Typ	Max	Unit
Supply Voltage	V _{CC}	4.75	5.0	5.25	V
High–Level Input Voltage	V _{IH}	2	–	–	V
Low–Level Input Voltage	V _{IL}	–	–	0.8	V
High–Level Output Current	I _{OH}	–	–	15	mA
Low–Level Output Current	I _{OL}	–	–	8	mA
Operating Temperature Range	T _A	0	–	+70	°C

Electrical Characteristics: (Note 2, Note 3)

Parameter	Symbol	Test Conditions	Min	Typ	Max	Unit
Input Clamp Voltage	V_{IK}	$V_{CC} = \text{MIN}, I_I = -18\text{mA}$	-	-	-1.5	V
High Level Output Current	I_{OH}	$V_{CC} = \text{MIN}, V_{IL} = \text{Max}, V_{OH} = 12\text{V}$	-	-	50	μA
		$V_{CC} = \text{MIN}, V_{IL} = \text{Max}, V_{OH} = 15\text{V}$	-	-	1	mA
Low Level Output Voltage	V_{OL}	$V_{CC} = \text{MIN}, V_{IH} = 2\text{V}, I_{OL} = 4\text{mA}$	-	0.25	0.4	V
		$V_{CC} = \text{MIN}, V_{IH} = 2\text{V}, I_{OL} = 8\text{mA}$	-	0.35	0.5	V
Input Current	I_I	$V_{CC} = \text{MAX}, V_I = 7\text{V}$	-	-	0.1	mA
High Level Input Current	I_{IH}	$V_{CC} = \text{MAX}, V_I = 2.7\text{V}$	-	-	20	μA
Low Level Input Current	I_{IL}	$V_{CC} = \text{MAX}, V_I = 0.4\text{V}$	-	-	-0.4	mA
High Level Supply Current	I_{CCH}	$V_{CC} = \text{MAX}, V_I = 0\text{V}$	-	0.8	1.6	mA
Low Level Supply Current	I_{CCL}	$V_{CC} = \text{MAX}, V_I = 4.5\text{V}$	-	2.4	4.4	mA

Note 2. For conditions shown as MIN or MAX, use the appropriate value specified under "Recommended Operation Conditions".

Note 3. All typical values are at $V_{CC} = 5\text{V}, T_A = +25^\circ\text{C}$.

Switching Characteristics: ($V_{CC} = 5\text{V}, T_A = +25^\circ\text{C}$ unless otherwise specified)

Parameter	Symbol	Test Conditions	Min	Typ	Max	Unit
Propagation Delay Time From A or B Input to Y Output)	t_{PLH}	$R_L = 2\text{k}\Omega, C_L = 15\text{pF}$	-	17	32	ns
	t_{PHL}		-	15	28	ns

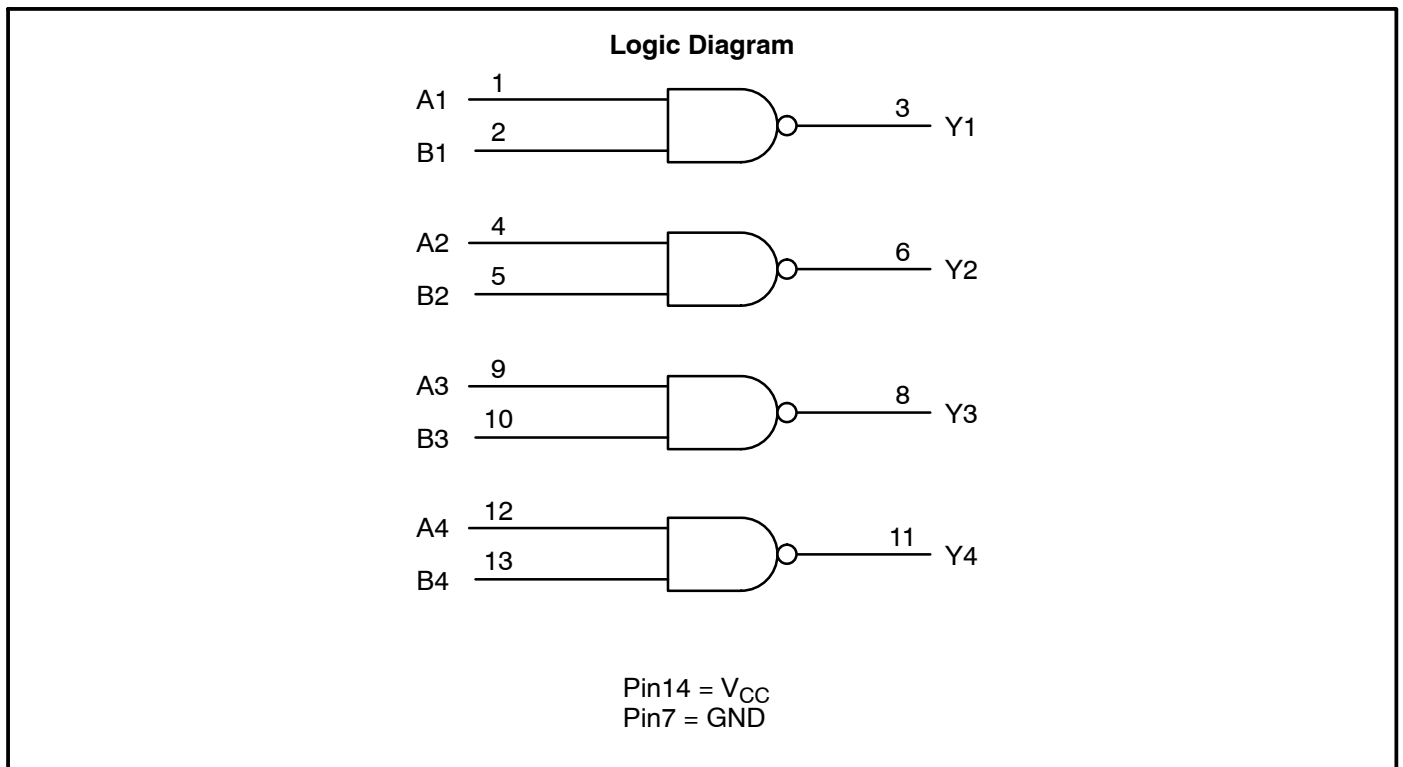

Pin Connection Diagram

