



ELECTRONICS, INC.  
 44 FARRAND STREET  
 BLOOMFIELD, NJ 07003  
 (973) 748-5089  
<http://www.nteinc.com>

## NTE74H22 Integrated Circuit TTL – Dual 4–Input Positive NAND Gate with Open Collector Outputs

**Description:**

The NTE74H22 contains two independent 4–Input NAND gates in a 14–Lead plastic DIP type package. The open collector outputs require pull–up resistors to perform correctly. They may be connected to other open collector outputs to implement active–low wired–OR or active–high wired–AND functions. Open collector devices are often used to generate higher  $V_{OH}$  levels.

**Absolute Maximum Ratings:** (Note 1)

Supply Voltage,  $V_{CC}$  ..... 7V  
 DC Input Voltage,  $V_{IN}$  ..... 5.5V  
 Operating Temperature Range,  $T_A$  ..... 0°C to +70°C  
 Storage Temperature Range,  $T_{stg}$  ..... –65°C to +150°C

Note 1. Unless otherwise specified, all voltages are referenced to GND.

**Recommended Operating Conditions:**

Parameter	Symbol	Min	Typ	Max	Unit
Supply Voltage	$V_{CC}$	4.75	5.0	5.25	V
High–Level Input Voltage	$V_{IH}$	2	–	–	V
Low–Level Input Voltage	$V_{IL}$	–	–	0.8	V
High–Level Output Voltage	$V_{OH}$	–	–	5.5	V
Low–Level Output Current	$I_{OL}$	–	–	20	mA
Operating Temperature Range	$T_A$	0	–	+70	°C

**Electrical Characteristics:** (Note 2, Note 3)

Parameter	Symbol	Test Conditions	Min	Typ	Max	Unit
Input Clamp Voltage	$V_{IK}$	$V_{CC} = \text{MIN}, I_I = -8\text{mA}$	–	–	–1.5	V
High Level Output Current	$I_{OH}$	$V_{CC} = \text{MIN}, V_{IL} = 0.8\text{V}, V_{OH} = 5.5\text{V}$	–	–	0.25	mA
Low Level Output Voltage	$V_{OL}$	$V_{CC} = \text{MIN}, V_{IH} = 2\text{V}, I_{OL} = 20\text{mA}$	–	0.2	0.4	V
Input Current	$I_I$	$V_{CC} = \text{MAX}, V_I = 5.5\text{V}$	–	–	1	mA

Note 2. For conditions shown as MIN or MAX, use the appropriate value specified under “Recommended Operation Conditions”.

Note 3. All typical values are at  $V_{CC} = 5\text{V}, T_A = +25^\circ\text{C}$ .

**Electrical Characteristics (Cont'd):** (Note 2, Note 3)

Parameter	Symbol	Test Conditions	Min	Typ	Max	Unit
High Level Input Current	$I_{IH}$	$V_{CC} = \text{MAX}, V_I = 2.4V$	-	-	50	$\mu A$
Low Level Input Current	$I_{IL}$	$V_{CC} = \text{MAX}, V_I = 0.4V$	-	-	-2	mA
High Level Supply Current	$I_{CCH}$	$V_{CC} = \text{MAX}, V_I = 0$	-	5.0	8.4	mA
Low Level Supply Current	$I_{CCL}$	$V_{CC} = \text{MAX}, V_I = 4.5V$	-	13	20	mA

Note 2. For conditions shown as MIN or MAX, use the appropriate value specified under "Recommended Operation Conditions".

Note 3. All typical values are at  $V_{CC} = 5V, T_A = +25^\circ C$ .

**Switching Characteristics:** ( $V_{CC} = 5V, T_A = +25^\circ C$  unless otherwise specified)

Parameter	Symbol	Test Conditions	Min	Typ	Max	Unit
Propagation Delay Time From Any Input to Y Output)	$t_{PLH}$	$R_L = 280\Omega, C_L = 25pF$	-	10	15	ns
	$t_{PHL}$		-	7.5	12	ns

**Function Table (Each Gate):**

Inputs				Output
A	B	C	D	Y
H	H	H	H	L
L	X	X	X	H
X	L	X	X	H
X	X	L	X	H
X	X	X	L	H

H = HIGH Voltage Level

L = LOW Voltage Level

X = Don't Care

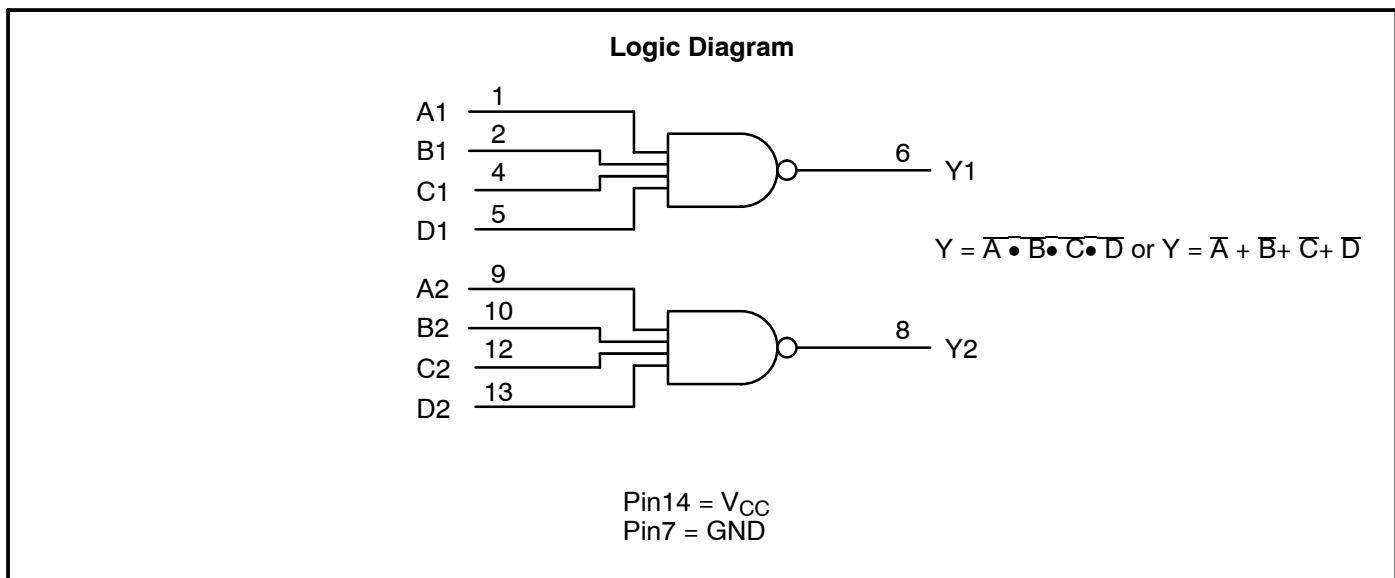

### Pin Connection Diagram

