

LM78LXX Series 3-Terminal Positive Regulators

 Check for Samples: [LM78L05](#), [LM78L09](#), [LM78L12](#), [LM78L15](#), [LM78L62](#), [LM78L82](#)

FEATURES

- LM78L05 in DSBGA Package
- Output Voltage Tolerances of $\pm 5\%$ Over the Temperature Range
- Output Current of 100mA
- Internal Thermal Overload Protection
- Output Transistor Safe Area Protection
- Internal Short Circuit Current Limit
- Available in TO-92 and SOIC-8 Low Profile Packages
- No External Components
- Output Voltages of 5.0V, 6.2V, 8.2V, 9.0V, 12V, 15V
- See AN-1112 ([SNVA009](#)) for DSBGA Considerations

DESCRIPTION

The LM78LXX series of three terminal positive regulators is available with several fixed output voltages making them useful in a wide range of applications. When used as a zener diode/resistor combination replacement, the LM78LXX usually results in an effective output impedance improvement of two orders of magnitude, and lower quiescent current. These regulators can provide local on card regulation, eliminating the distribution problems associated with single point regulation. The voltages available allow the LM78LXX to be used in logic systems, instrumentation, HiFi, and other solid state electronic equipment.

Connection Diagram

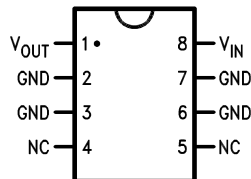

Figure 1. SOIC-8 (D)
(Top View, Narrow Body)

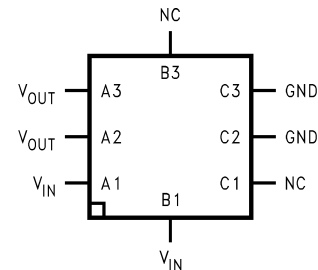

Figure 2. 8-Bump DSBGA
(Top View, Bump Side Down)

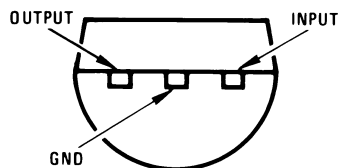

Figure 3. TO-92 Package (LP)
(Bottom View)

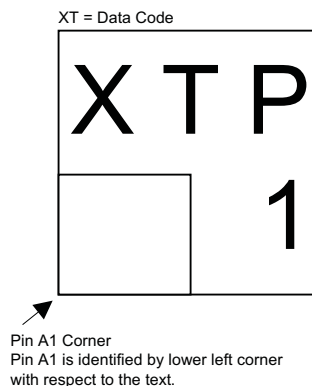

Figure 4. DSBGA Marking Orientation
(Top View)



Please be aware that an important notice concerning availability, standard warranty, and use in critical applications of Texas Instruments semiconductor products and disclaimers thereto appears at the end of this data sheet.

All trademarks are the property of their respective owners.



These devices have limited built-in ESD protection. The leads should be shorted together or the device placed in conductive foam during storage or handling to prevent electrostatic damage to the MOS gates.

DESCRIPTION (CONTINUED)

The LM78LXX is available in the plastic TO-92 (LP) package, the SOIC-8 (D) package and a chip sized package (8-Bump DSBGA) using TI's DSBGA package technology. With adequate heat sinking the regulator can deliver 100mA output current. Current limiting is included to limit the peak output current to a safe value. Safe area protection for the output transistors is provided to limit internal power dissipation. If internal power dissipation becomes too high for the heat sinking provided, the thermal shutdown circuit takes over preventing the IC from overheating.

Absolute Maximum Ratings⁽¹⁾⁽²⁾

Power Dissipation ⁽³⁾	Internally Limited
Input Voltage	35V
Storage Temperature	-65°C to +150°C
ESD Susceptibility ⁽⁴⁾	1kV
Operating Junction Temperature	
LM78LxxACZ, TO-92	0°C to 125°C
LM78LxxACM, SOIC-8	0°C to 125°C
LM78LxxAIM, SOIC-8	-40°C to 125°C
LM78LxxIBPX, DSBGA	-40°C to 85°C
LM78LxxITP, Thin DSBGA	-40°C to 85°C
Soldering Information	
Infrared or Convection (20 sec.)	235°C
Wave Soldering (10 sec.)	260°C (lead time)

- (1) Absolute Maximum Ratings indicate limits beyond which damage to the device may occur. Electrical specifications do not apply when operating the device outside of its stated operating conditions.
- (2) If Military/Aerospace specified devices are required, please contact the Texas Instruments Sales Office/Distributors for availability and specifications.
- (3) Typical thermal resistance values for the packages are:
LP Package: $\theta_{JC} = 60 \text{ }^\circ\text{C/W}$, $\theta_{JA} = 230 \text{ }^\circ\text{C/W}$
D Package: $\theta_{JA} = 180 \text{ }^\circ\text{C/W}$
DSBGA Package: $\theta_{JA} = 230.9 \text{ }^\circ\text{C/W}$
- (4) Human body model, 1.5 k Ω in series with 100pF.

LM78LXX Electrical Characteristics LM78L05AC / LM78L05AI / LM78L05I

Limits in standard typeface are for $T_J = 25^\circ\text{C}$, **Bold typeface applies over the entire operating temperature range of the indicated package.** Limits are ensured by production testing or correlation techniques using standard Statistical Quality Control (SQC) methods. Unless otherwise specified: $I_O = 40\text{mA}$, $C_I = 0.33\mu\text{F}$, $C_O = 0.1\mu\text{F}$.

Unless otherwise specified, $V_{IN} = 10\text{V}$

Symbol	Parameter	Conditions	Min	Typ	Max	Units
V_O	Output Voltage		4.8	5	5.2	V
		$7\text{V} \leq V_{IN} \leq 20\text{V}$ $1\text{mA} \leq I_O \leq 40\text{mA}$ (1)	4.75		5.25	
		$1\text{mA} \leq I_O \leq 70\text{mA}$ (1)	4.75		5.25	
ΔV_O	Line Regulation	$7\text{V} \leq V_{IN} \leq 20\text{V}$		18	75	mV
		$8\text{V} \leq V_{IN} \leq 20\text{V}$		10	54	
ΔV_O	Load Regulation	$1\text{mA} \leq I_O \leq 100\text{mA}$		20	60	
		$1\text{mA} \leq I_O \leq 40\text{mA}$		5	30	

(1) Power dissipation $\leq 0.75\text{W}$.

LM78LXX Electrical Characteristics LM78L05AC / LM78L05AI / LM78L05I (continued)

Limits in standard typeface are for $T_J = 25^\circ\text{C}$, **Bold typeface applies over the entire operating temperature range of the indicated package.** Limits are ensured by production testing or correlation techniques using standard Statistical Quality Control (SQC) methods. Unless otherwise specified: $I_O = 40\text{mA}$, $C_I = 0.33\mu\text{F}$, $C_O = 0.1\mu\text{F}$.

Unless otherwise specified, $V_{IN} = 10\text{V}$

Symbol	Parameter	Conditions	Min	Typ	Max	Units
I_Q	Quiescent Current			3	5	mA
ΔI_Q	Quiescent Current Change	$8\text{V} \leq V_{IN} \leq 20\text{V}$ $1\text{mA} \leq I_O \leq 40\text{mA}$			1.0 0.1	
V_n	Output Noise Voltage	$f = 10\text{ Hz to } 100\text{ kHz}^{(2)}$		40		μV
$\Delta V_{IN}/\Delta V_{OUT}$	Ripple Rejection	$f = 120\text{ Hz}$ $8\text{V} \leq V_{IN} \leq 16\text{V}$	47	62		dB
I_{PK}	Peak Output Current			140		mA
$\Delta V_O/\Delta T$	Average Output Voltage Tempco	$I_O = 5\text{mA}$		-0.65		$\text{mV}/^\circ\text{C}$
$V_{IN}(\text{Min})$	Minimum Value of Input Voltage Required to Maintain Line Regulation			6.7	7	V
θ_{JA}	Thermal Resistance (8-Bump micro SMD)			230.9		$^\circ\text{C}/\text{W}$

(2) Recommended minimum load capacitance of $0.01\mu\text{F}$ to limit high frequency noise.

LM78LXX Electrical Characteristics LM78L62AC

Unless otherwise specified, $V_{IN} = 12\text{V}$

Symbol	Parameter	Conditions	Min	Typ	Max	Units
V_O	Output Voltage		5.95	6.2	6.45	V
		$8.5\text{V} \leq V_{IN} \leq 20\text{V}$ $1\text{mA} \leq I_O \leq 40\text{mA}$ (1)	5.9		6.5	
		$1\text{mA} \leq I_O \leq 70\text{mA}$ (1)	5.9		6.5	
ΔV_O	Line Regulation	$8.5\text{V} \leq V_{IN} \leq 20\text{V}$		65	175	mV
		$9\text{V} \leq V_{IN} \leq 20\text{V}$		55	125	
ΔV_O	Load Regulation	$1\text{mA} \leq I_O \leq 100\text{mA}$		13	80	
		$1\text{mA} \leq I_O \leq 40\text{mA}$		6	40	
I_Q	Quiescent Current			2	5.5	mA
ΔI_Q	Quiescent Current Change	$8\text{V} \leq V_{IN} \leq 20\text{V}$ $1\text{mA} \leq I_O \leq 40\text{mA}$			1.5 0.1	
V_n	Output Noise Voltage	$f = 10\text{ Hz to } 100\text{ kHz}$ (2)		50		μV
$\Delta V_{IN}/\Delta V_{OUT}$	Ripple Rejection	$f = 120\text{ Hz}$ $10\text{V} \leq V_{IN} \leq 20\text{V}$	40	46		dB
I_{PK}	Peak Output Current			140		mA
$\Delta V_O/\Delta T$	Average Output Voltage Tempco	$I_O = 5\text{mA}$		-0.75		$\text{mV}/^\circ\text{C}$
$V_{IN}(\text{Min})$	Minimum Value of Input Voltage Required to Maintain Line Regulation			7.9		V

(1) Power dissipation $\leq 0.75\text{W}$.

(2) Recommended minimum load capacitance of $0.01\mu\text{F}$ to limit high frequency noise.

LM78LXX Electrical Characteristics LM78L82AC

Unless otherwise specified, $V_{IN} = 14V$

Symbol	Parameter	Conditions	Min	Typ	Max	Units
V_O	Output Voltage		7.87	8.2	8.53	V
		$11V \leq V_{IN} \leq 23V$ $1mA \leq I_O \leq 40mA$ (1)	7.8		8.6	
		$1mA \leq I_O \leq 70mA$ (1)	7.8		8.6	
ΔV_O	Line Regulation	$11V \leq V_{IN} \leq 23V$		80	175	mV
		$12V \leq V_{IN} \leq 23V$		70	125	
ΔV_O	Load Regulation	$1mA \leq I_O \leq 100mA$		15	80	mV
		$1mA \leq I_O \leq 40mA$		8	40	
I_Q	Quiescent Current			2	5.5	mA
ΔI_Q	Quiescent Current Change	$12V \leq V_{IN} \leq 23V$			1.5	
		$1mA \leq I_O \leq 40mA$			0.1	
V_n	Output Noise Voltage	$f = 10 \text{ Hz to } 100 \text{ kHz}$ (2)		60		μV
$\Delta V_{IN}/\Delta V_{OUT}$	Ripple Rejection	$f = 120 \text{ Hz}$ $12V \leq V_{IN} \leq 22V$	39	45		dB
I_{PK}	Peak Output Current			140		mA
$\Delta V_O/\Delta T$	Average Output Voltage Tempco	$I_O = 5mA$		-0.8		$mV/^\circ C$
$V_{IN}(\text{Min})$	Minimum Value of Input Voltage Required to Maintain Line Regulation			9.9		V

(1) Power dissipation $\leq 0.75W$.

(2) Recommended minimum load capacitance of $0.01\mu F$ to limit high frequency noise.

LM78LXX Electrical Characteristics LM78L09AC / LM78L09I

Unless otherwise specified, $V_{IN} = 15V$

Symbol	Parameter	Conditions	Min	Typ	Max	Units
V_O	Output Voltage		8.64	9.0	9.36	V
		$11.5V \leq V_{IN} \leq 24V$ $1mA \leq I_O \leq 40mA$ (1)	8.55		9.45	
		$1mA \leq I_O \leq 70mA$ (1)	8.55		9.45	
ΔV_O	Line Regulation	$11.5V \leq V_{IN} \leq 24V$		100	200	mV
		$13V \leq V_{IN} \leq 24V$		90	150	
ΔV_O	Load Regulation	$1mA \leq I_O \leq 100mA$		20	90	mV
		$1mA \leq I_O \leq 40mA$		10	45	
I_Q	Quiescent Current			2	5.5	mA
ΔI_Q	Quiescent Current Change	$11.5V \leq V_{IN} \leq 24V$			1.5	
		$1mA \leq I_O \leq 40mA$			0.1	
V_n	Output Noise Voltage			70		μV
$\Delta V_{IN}/\Delta V_{OUT}$	Ripple Rejection	$f = 120 \text{ Hz}$ $15V \leq V_{IN} \leq 25V$	38	44		dB
I_{PK}	Peak Output Current			140		mA
$\Delta V_O/\Delta T$	Average Output Voltage Tempco	$I_O = 5mA$		-0.9		$mV/^\circ C$
$V_{IN}(\text{Min})$	Minimum Value of Input Voltage Required to Maintain Line Regulation			10.7		V

(1) Power dissipation $\leq 0.75W$.

LM78LXX Electrical Characteristics LM78L12AC

 Unless otherwise specified, $V_{IN} = 19V$

Symbol	Parameter	Conditions	Min	Typ	Max	Units
V_O	Output Voltage		11.5	12	12.5	V
		$14.5V \leq V_{IN} \leq 27V$ $1mA \leq I_O \leq 40mA$ (1)	11.4		12.6	
		$1mA \leq I_O \leq 70mA$ (1)	11.4		12.6	
ΔV_O	Line Regulation	$14.5V \leq V_{IN} \leq 27V$		30	180	mV
		$16V \leq V_{IN} \leq 27V$		20	110	
ΔV_O	Load Regulation	$1mA \leq I_O \leq 100mA$		30	100	
		$1mA \leq I_O \leq 40mA$		10	50	
I_Q	Quiescent Current			3	5	mA
ΔI_Q	Quiescent Current Change	$16V \leq V_{IN} \leq 27V$			1	
		$1mA \leq I_O \leq 40mA$			0.1	
V_n	Output Noise Voltage			80		μV
$\Delta V_{IN}/\Delta V_{OUT}$	Ripple Rejection	$f = 120 \text{ Hz}$ $15V \leq V_{IN} \leq 25$	40	54		dB
I_{PK}	Peak Output Current			140		mA
$\Delta V_O/\Delta T$	Average Output Voltage Tempco	$I_O = 5mA$		-1.0		$mV/^\circ C$
$V_{IN} \text{ (Min)}$	Minimum Value of Input Voltage Required to Maintain Line Regulation			13.7	14.5	V

 (1) Power dissipation $\leq 0.75W$.

LM78LXX Electrical Characteristics LM78L15AC

 Unless otherwise specified, $V_{IN} = 23V$

Symbol	Parameter	Conditions	Min	Typ	Max	Units
V_O	Output Voltage		14.4	15.0	15.6	V
		$17.5V \leq V_{IN} \leq 30V$ $1mA \leq I_O \leq 40mA$ (1)	14.25		15.75	
		$1mA \leq I_O \leq 70mA$ (1)	14.25		15.75	
ΔV_O	Line Regulation	$17.5V \leq V_{IN} \leq 30V$		37	250	mV
		$20V \leq V_{IN} \leq 30V$		25	140	
ΔV_O	Load Regulation	$1mA \leq I_O \leq 100mA$		35	150	
		$1mA \leq I_O \leq 40mA$		12	75	
I_Q	Quiescent Current			3	5	mA
ΔI_Q	Quiescent Current Change	$20V \leq V_{IN} \leq 30V$			1	
		$1mA \leq I_O \leq 40mA$			0.1	
V_n	Output Noise Voltage			90		μV
$\Delta V_{IN}/\Delta V_{OUT}$	Ripple Rejection	$f = 120 \text{ Hz}$ $18.5V \leq V_{IN} \leq 28.5V$	37	51		dB
I_{PK}	Peak Output Current			140		mA
$\Delta V_O/\Delta T$	Average Output Voltage Tempco	$I_O = 5mA$		-1.3		$mV/^\circ C$
$V_{IN} \text{ (Min)}$	Minimum Value of Input Voltage Required to Maintain Line Regulation			16.7	17.5	V

 (1) Power dissipation $\leq 0.75W$.

Typical Performance Characteristics

Maximum Average Power Dissipation (LP Package)

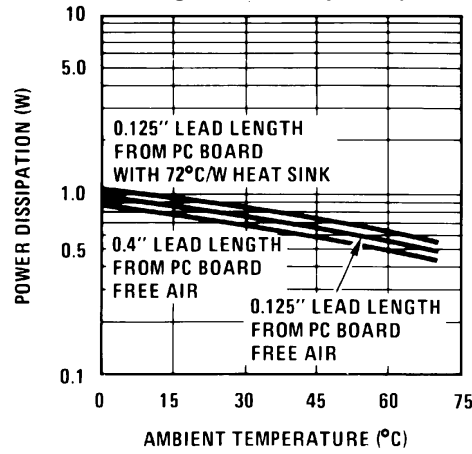

Figure 5.

Peak Output Current

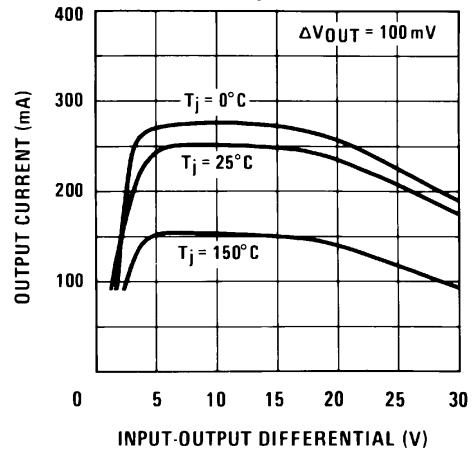

Figure 6.

Dropout Voltage

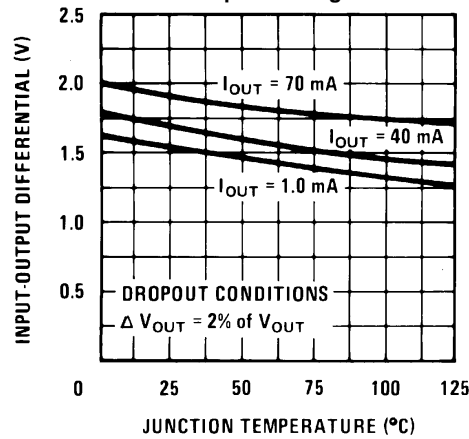

Figure 7.

Ripple Rejection

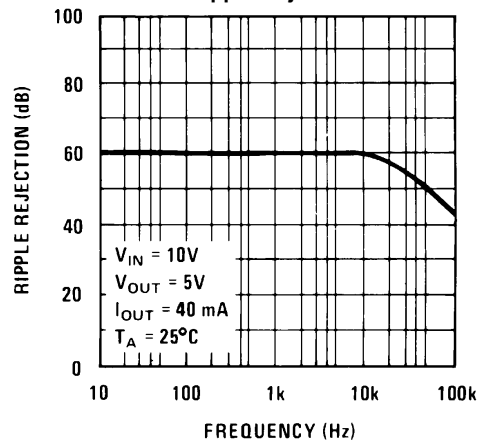

Figure 8.

Output Impedance

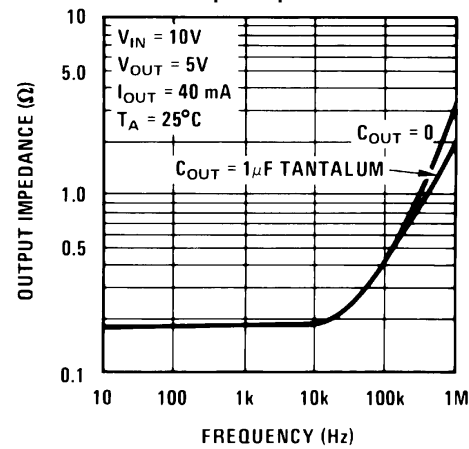

Figure 9.

Quiescent Current

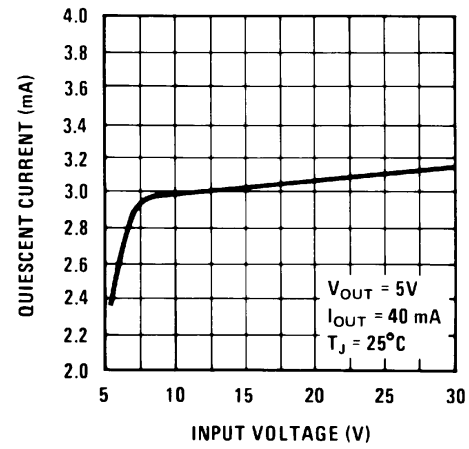
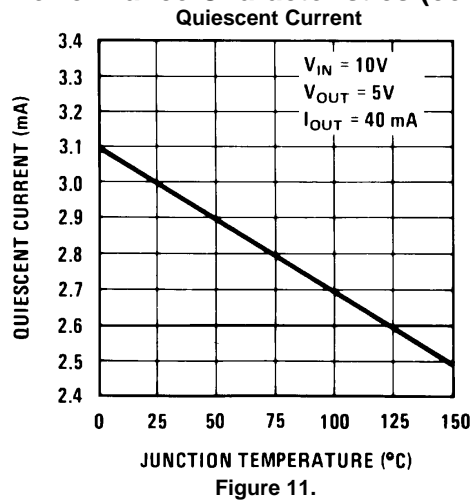

Figure 10.

Typical Performance Characteristics (continued)



EQUIVALENT CIRCUIT

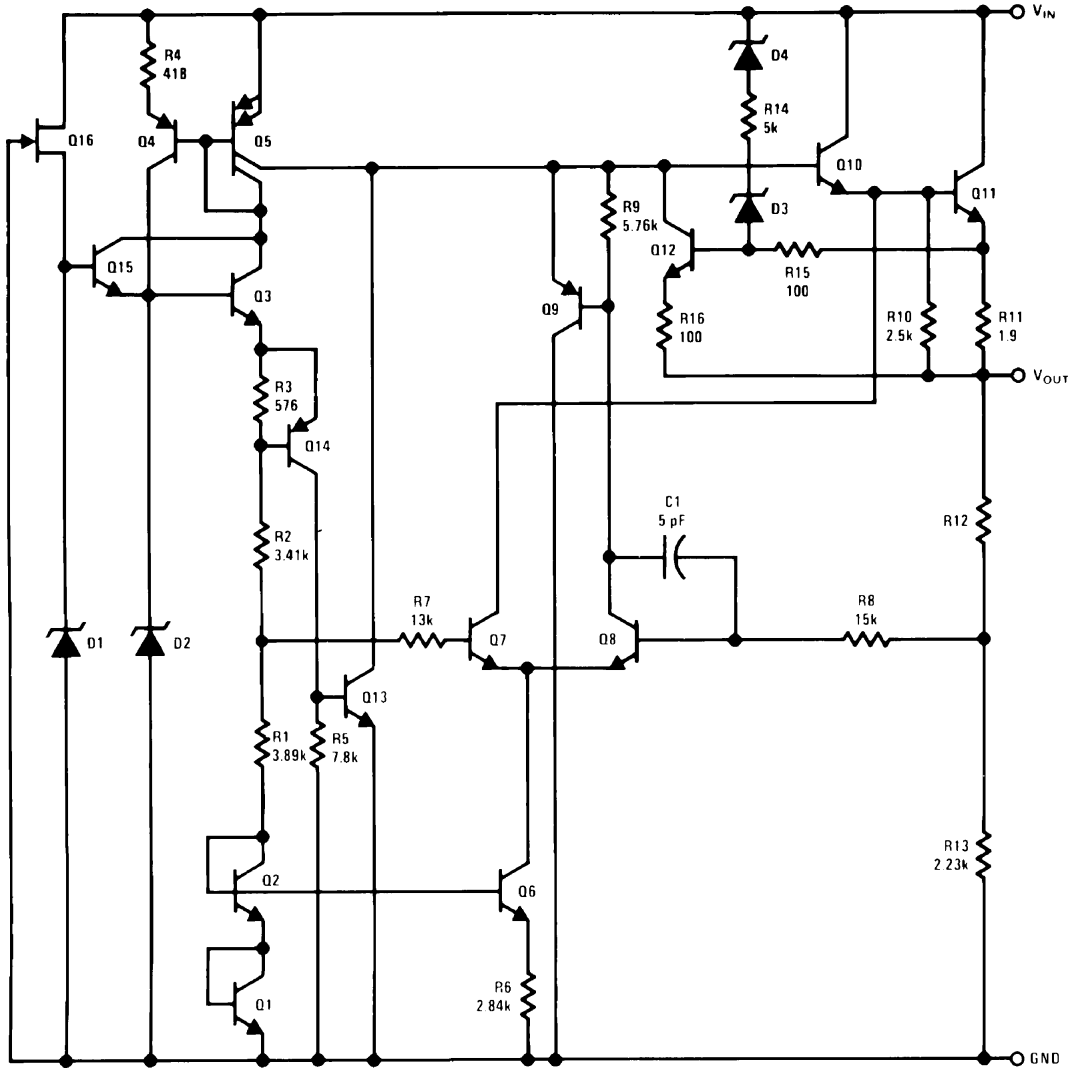
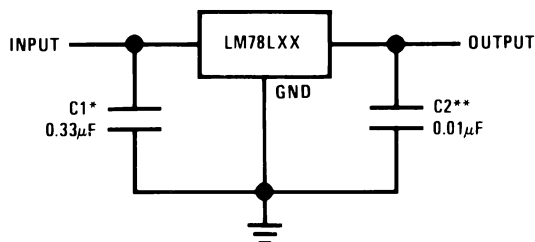

Figure 12. LM78LXX

Typical Applications



*Required if the regulator is located more than 3" from the power supply filter.

**See (1) in the electrical characteristics table.

Figure 13. Fixed Output Regulator

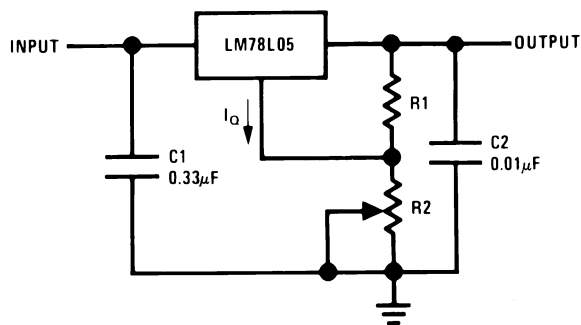

$$V_{OUT} = 5V + (5V/R1 + I_Q) R2$$

$$5V/R1 > 3 I_Q, \text{ load regulation } (L_r) \approx [(R1 + R2)/R1] (L_r \text{ of LM78L05})$$

Figure 14. Adjustable Output Regulator

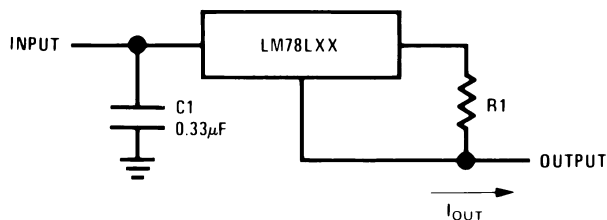

$$I_{OUT} = (V_{OUT}/R1) + I_Q$$

$$>I_Q = 1.5\text{mA over line and load changes}$$

Figure 15. Current Regulator

(1) Recommended minimum load capacitance of 0.01µF to limit high frequency noise.

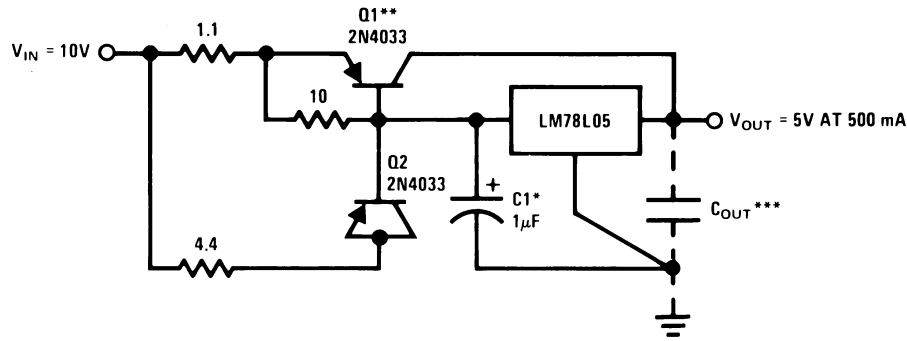

*Solid tantalum.
 **Heat sink Q1.
 ***Optional: Improves ripple rejection and transient response.
 Load Regulation: 0.6% $0 \leq I_L \leq 250\text{mA}$ pulsed with $t_{ON} = 50\text{ms}$.

Figure 16. 5V, 500mA Regulator with Short Circuit Protection

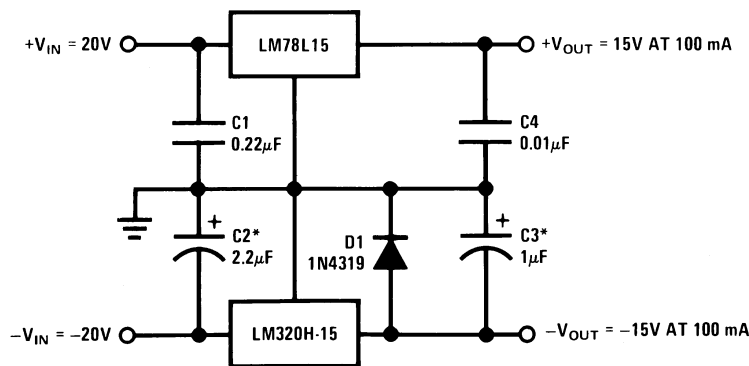

*Solid tantalum.

Figure 17. ±15V, 100mA Dual Power Supply

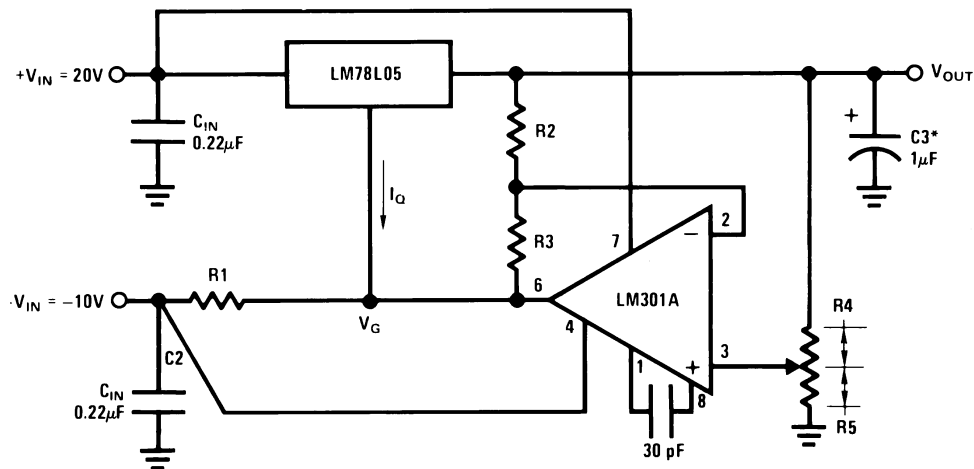

*Solid tantalum.
 $V_{OUT} = V_G + 5V$, $R1 = (-V_{IN}/I_Q \text{ LM78L05})$
 $V_{OUT} = 5V (R2/R4)$ for $(R2 + R3) = (R4 + R5)$
 A 0.5V output will correspond to $(R2/R4) = 0.1$ $(R3/R4) = 0.9$

Figure 18. Variable Output Regulator 0.5V-18V

REVISION HISTORY

Changes from Revision I (April 2013) to Revision J	Page
• added the AI suffix	2
• added the AI suffix	3

PACKAGING INFORMATION

Orderable Device	Status (1)	Package Type	Package Drawing	Pins	Package Qty	Eco Plan (2)	Lead/Ball Finish (6)	MSL Peak Temp (3)	Op Temp (°C)	Device Marking (4/5)	Samples
LM78L05ACM	NRND	SOIC	D	8	95	TBD	Call TI	Call TI	-40 to 85	LM78L 05ACM	
LM78L05ACM/NOPB	ACTIVE	SOIC	D	8	95	Green (RoHS & no Sb/Br)	CU SN	Level-1-260C-UNLIM	-40 to 85	LM78L 05ACM	Samples
LM78L05ACMX	NRND	SOIC	D	8	2500	TBD	Call TI	Call TI	-40 to 85	LM78L 05ACM	
LM78L05ACMX/NOPB	ACTIVE	SOIC	D	8	2500	Green (RoHS & no Sb/Br)	SN CU SN	Level-1-260C-UNLIM	-40 to 85	LM78L 05ACM	Samples
LM78L05ACZ/LFT1	ACTIVE	TO-92	LP	3	2000	Green (RoHS & no Sb/Br)	SN CU SN	N / A for Pkg Type		LM78L 05ACZ	Samples
LM78L05ACZ/LFT3	ACTIVE	TO-92	LP	3	2000	Green (RoHS & no Sb/Br)	SN CU SN	N / A for Pkg Type		LM78L 05ACZ	Samples
LM78L05ACZ/LFT4	ACTIVE	TO-92	LP	3	2000	Green (RoHS & no Sb/Br)	SN CU SN	N / A for Pkg Type		LM78L 05ACZ	Samples
LM78L05ACZ/LFT7	ACTIVE	TO-92	LP	3	2000	Green (RoHS & no Sb/Br)	SN CU SN	N / A for Pkg Type		LM78L 05ACZ	Samples
LM78L05ACZ/NOPB	ACTIVE	TO-92	LP	3	1800	Green (RoHS & no Sb/Br)	SN Call TI	N / A for Pkg Type	-40 to 85	LM78L 05ACZ	Samples
LM78L05AIM/NOPB	ACTIVE	SOIC	D	8	95	Green (RoHS & no Sb/Br)	SN CU SN	Level-1-260C-UNLIM		LM78L 05AM	Samples
LM78L05AIMX/NOPB	ACTIVE	SOIC	D	8	2500	Green (RoHS & no Sb/Br)	SN CU SN	Level-1-260C-UNLIM		LM78L 05AM	Samples
LM78L05ITP/NOPB	ACTIVE	DSBGA	YPB	8	250	Green (RoHS & no Sb/Br)	SNAGCU	Level-1-260C-UNLIM		P 03	Samples
LM78L05ITPX/NOPB	ACTIVE	DSBGA	YPB	8	3000	Green (RoHS & no Sb/Br)	SNAGCU	Level-1-260C-UNLIM		P 03	Samples
LM78L09ITPX/NOPB	ACTIVE	DSBGA	YPB	8	3000	Green (RoHS & no Sb/Br)	SNAGCU	Level-1-260C-UNLIM		P 02	Samples
LM78L12ACM	NRND	SOIC	D	8	95	TBD	Call TI	Call TI	-40 to 85	LM78L 12ACM	
LM78L12ACM/NOPB	ACTIVE	SOIC	D	8	95	Green (RoHS & no Sb/Br)	CU SN	Level-1-260C-UNLIM	-40 to 85	LM78L 12ACM	Samples
LM78L12ACMX	NRND	SOIC	D	8	2500	TBD	Call TI	Call TI	-40 to 85	LM78L 12ACM	

Orderable Device	Status (1)	Package Type	Package Drawing	Pins	Package Qty	Eco Plan (2)	Lead/Ball Finish (6)	MSL Peak Temp (3)	Op Temp (°C)	Device Marking (4/5)	Samples
LM78L12ACMX/NOPB	ACTIVE	SOIC	D	8	2500	Green (RoHS & no Sb/Br)	SN CU SN	Level-1-260C-UNLIM	-40 to 85	LM78L 12ACM	Samples
LM78L12ACZ/LFT3	ACTIVE	TO-92	LP	3	2000	Green (RoHS & no Sb/Br)	SN CU SN	N / A for Pkg Type		LM78L 12ACZ	Samples
LM78L12ACZ/LFT4	ACTIVE	TO-92	LP	3	2000	Green (RoHS & no Sb/Br)	SN CU SN	N / A for Pkg Type		LM78L 12ACZ	Samples
LM78L12ACZ/LFT7	ACTIVE	TO-92	LP	3	2000	Green (RoHS & no Sb/Br)	SN CU SN	N / A for Pkg Type		LM78L 12ACZ	Samples
LM78L12ACZ/NOPB	ACTIVE	TO-92	LP	3	1800	Green (RoHS & no Sb/Br)	SN CU SN	N / A for Pkg Type	-40 to 85	LM78L 12ACZ	Samples
LM78L15ACM	NRND	SOIC	D	8	95	TBD	Call TI	Call TI	-40 to 85	LM78L 15ACM	
LM78L15ACM/NOPB	ACTIVE	SOIC	D	8	95	Green (RoHS & no Sb/Br)	CU SN	Level-1-260C-UNLIM	-40 to 85	LM78L 15ACM	Samples
LM78L15ACMX	NRND	SOIC	D	8	2500	TBD	Call TI	Call TI	-40 to 85	LM78L 15ACM	
LM78L15ACMX/NOPB	ACTIVE	SOIC	D	8	2500	Green (RoHS & no Sb/Br)	SN CU SN	Level-1-260C-UNLIM	-40 to 85	LM78L 15ACM	Samples
LM78L15ACZ/LFT4	ACTIVE	TO-92	LP	3	2000	Green (RoHS & no Sb/Br)	SN CU SN	N / A for Pkg Type		LM78L (12ACZ ~ 15ACZ)	Samples
LM78L15ACZ/NOPB	ACTIVE	TO-92	LP	3	1800	Green (RoHS & no Sb/Br)	SN CU SN	N / A for Pkg Type	-40 to 85	LM78L 15ACZ	Samples
LM78L62ACZ/NOPB	ACTIVE	TO-92	LP	3	1800	Green (RoHS & no Sb/Br)	SN CU SN	N / A for Pkg Type	-40 to 85	LM78L 62ACZ	Samples

(1) The marketing status values are defined as follows:

ACTIVE: Product device recommended for new designs.

LIFEBUY: TI has announced that the device will be discontinued, and a lifetime-buy period is in effect.

NRND: Not recommended for new designs. Device is in production to support existing customers, but TI does not recommend using this part in a new design.

PREVIEW: Device has been announced but is not in production. Samples may or may not be available.

OBSELETE: TI has discontinued the production of the device.

(2) Eco Plan - The planned eco-friendly classification: Pb-Free (RoHS), Pb-Free (RoHS Exempt), or Green (RoHS & no Sb/Br) - please check <http://www.ti.com/productcontent> for the latest availability information and additional product content details.

TBD: The Pb-Free/Green conversion plan has not been defined.

Pb-Free (RoHS): TI's terms "Lead-Free" or "Pb-Free" mean semiconductor products that are compatible with the current RoHS requirements for all 6 substances, including the requirement that lead not exceed 0.1% by weight in homogeneous materials. Where designed to be soldered at high temperatures, TI Pb-Free products are suitable for use in specified lead-free processes.

Pb-Free (RoHS Exempt): This component has a RoHS exemption for either 1) lead-based flip-chip solder bumps used between the die and package, or 2) lead-based die adhesive used between the die and leadframe. The component is otherwise considered Pb-Free (RoHS compatible) as defined above.

Green (RoHS & no Sb/Br): TI defines "Green" to mean Pb-Free (RoHS compatible), and free of Bromine (Br) and Antimony (Sb) based flame retardants (Br or Sb do not exceed 0.1% by weight in homogeneous material)

⁽³⁾ MSL, Peak Temp. - The Moisture Sensitivity Level rating according to the JEDEC industry standard classifications, and peak solder temperature.

⁽⁴⁾ There may be additional marking, which relates to the logo, the lot trace code information, or the environmental category on the device.

⁽⁵⁾ Multiple Device Markings will be inside parentheses. Only one Device Marking contained in parentheses and separated by a "~" will appear on a device. If a line is indented then it is a continuation of the previous line and the two combined represent the entire Device Marking for that device.

⁽⁶⁾ Lead/Ball Finish - Orderable Devices may have multiple material finish options. Finish options are separated by a vertical ruled line. Lead/Ball Finish values may wrap to two lines if the finish value exceeds the maximum column width.

Important Information and Disclaimer: The information provided on this page represents TI's knowledge and belief as of the date that it is provided. TI bases its knowledge and belief on information provided by third parties, and makes no representation or warranty as to the accuracy of such information. Efforts are underway to better integrate information from third parties. TI has taken and continues to take reasonable steps to provide representative and accurate information but may not have conducted destructive testing or chemical analysis on incoming materials and chemicals. TI and TI suppliers consider certain information to be proprietary, and thus CAS numbers and other limited information may not be available for release.

In no event shall TI's liability arising out of such information exceed the total purchase price of the TI part(s) at issue in this document sold by TI to Customer on an annual basis.

TAPE AND REEL INFORMATION

QUADRANT ASSIGNMENTS FOR PIN 1 ORIENTATION IN TAPE

*All dimensions are nominal

Device	Package Type	Package Drawing	Pins	SPQ	Reel Diameter (mm)	Reel Width W1 (mm)	A0 (mm)	B0 (mm)	K0 (mm)	P1 (mm)	W (mm)	Pin1 Quadrant
LM78L05ACMX	SOIC	D	8	2500	330.0	12.4	6.5	5.4	2.0	8.0	12.0	Q1
LM78L05ACMX/NOPB	SOIC	D	8	2500	330.0	12.4	6.5	5.4	2.0	8.0	12.0	Q1
LM78L05AIMX/NOPB	SOIC	D	8	2500	330.0	12.4	6.5	5.4	2.0	8.0	12.0	Q1
LM78L05ITP/NOPB	DSBGA	YPB	8	250	178.0	8.4	1.5	1.5	0.66	4.0	8.0	Q1
LM78L05ITPX/NOPB	DSBGA	YPB	8	3000	178.0	8.4	1.5	1.5	0.66	4.0	8.0	Q1
LM78L09ITPX/NOPB	DSBGA	YPB	8	3000	178.0	8.4	1.5	1.5	0.66	4.0	8.0	Q1
LM78L12ACMX	SOIC	D	8	2500	330.0	12.4	6.5	5.4	2.0	8.0	12.0	Q1
LM78L12ACMX/NOPB	SOIC	D	8	2500	330.0	12.4	6.5	5.4	2.0	8.0	12.0	Q1
LM78L15ACMX	SOIC	D	8	2500	330.0	12.4	6.5	5.4	2.0	8.0	12.0	Q1
LM78L15ACMX/NOPB	SOIC	D	8	2500	330.0	12.4	6.5	5.4	2.0	8.0	12.0	Q1

TAPE AND REEL BOX DIMENSIONS



*All dimensions are nominal

Device	Package Type	Package Drawing	Pins	SPQ	Length (mm)	Width (mm)	Height (mm)
LM78L05ACMX	SOIC	D	8	2500	367.0	367.0	35.0
LM78L05ACMX/NOPB	SOIC	D	8	2500	367.0	367.0	35.0
LM78L05AIMX/NOPB	SOIC	D	8	2500	367.0	367.0	35.0
LM78L05ITP/NOPB	DSBGA	YPB	8	250	210.0	185.0	35.0
LM78L05ITPX/NOPB	DSBGA	YPB	8	3000	210.0	185.0	35.0
LM78L09ITPX/NOPB	DSBGA	YPB	8	3000	210.0	185.0	35.0
LM78L12ACMX	SOIC	D	8	2500	367.0	367.0	35.0
LM78L12ACMX/NOPB	SOIC	D	8	2500	367.0	367.0	35.0
LM78L15ACMX	SOIC	D	8	2500	367.0	367.0	35.0
LM78L15ACMX/NOPB	SOIC	D	8	2500	367.0	367.0	35.0

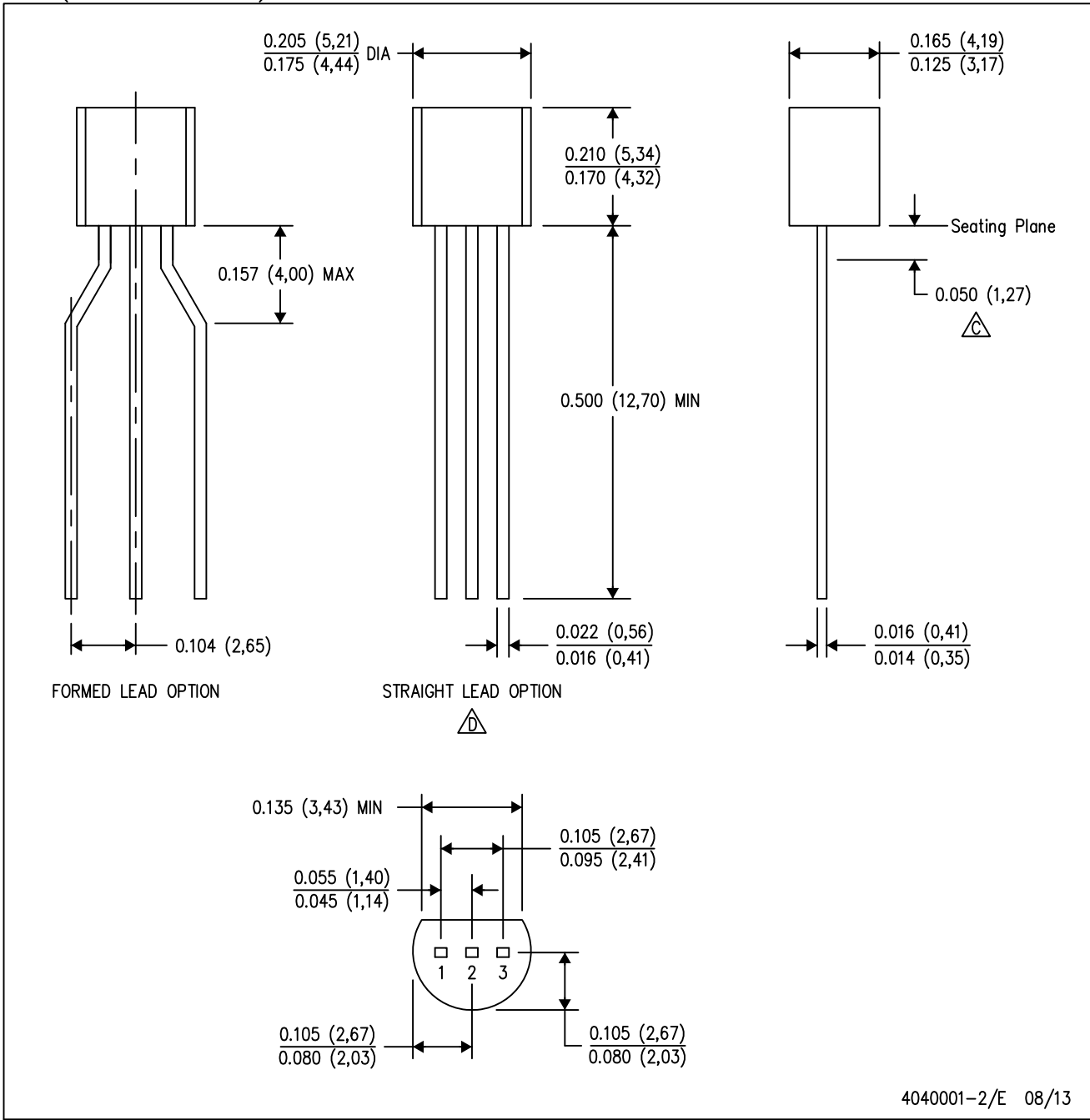

MECHANICAL DATA

LP (O-PBCY-W3)

PLASTIC CYLINDRICAL PACKAGE



4040001-2/E 08/13

- NOTES:
- A. All linear dimensions are in inches (millimeters).
 - B. This drawing is subject to change without notice.
 -  Lead dimensions are not controlled within this area.
 -  Falls within JEDEC TO-226 Variation AA (TO-226 replaces TO-92).
 - E. Shipping Method:
 Straight lead option available in bulk pack only.
 Formed lead option available in tape & reel or ammo pack.
 Specific products can be offered in limited combinations of shipping mediums and lead options.
 Consult product folder for more information on available options.

MECHANICAL DATA

LP (O-PBCY-W3)

PLASTIC CYLINDRICAL PACKAGE

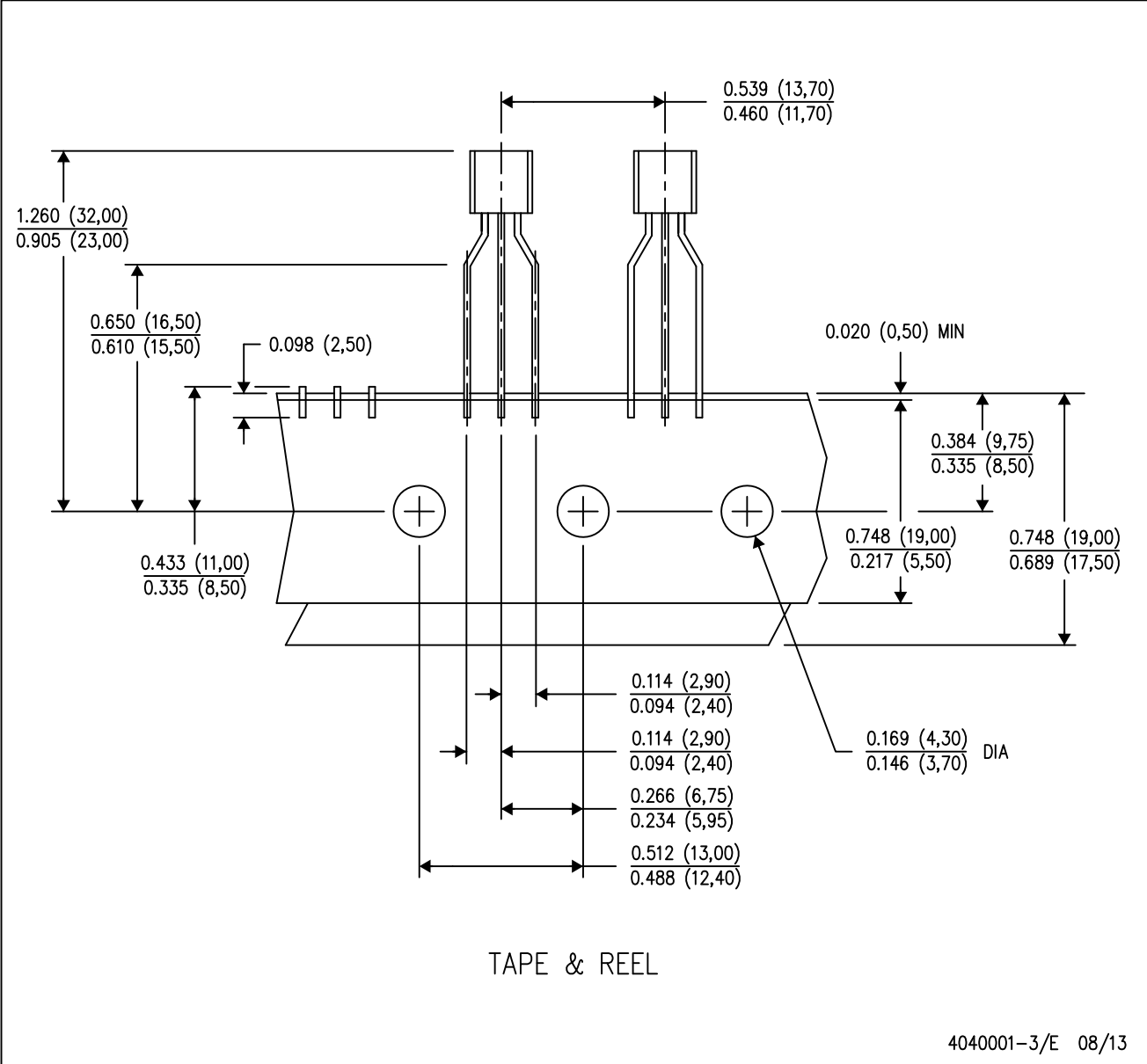

- NOTES:
- A. All linear dimensions are in inches (millimeters).
 - B. This drawing is subject to change without notice.
 - C. Tape and Reel information for the Formed Lead Option package.

YPB0008

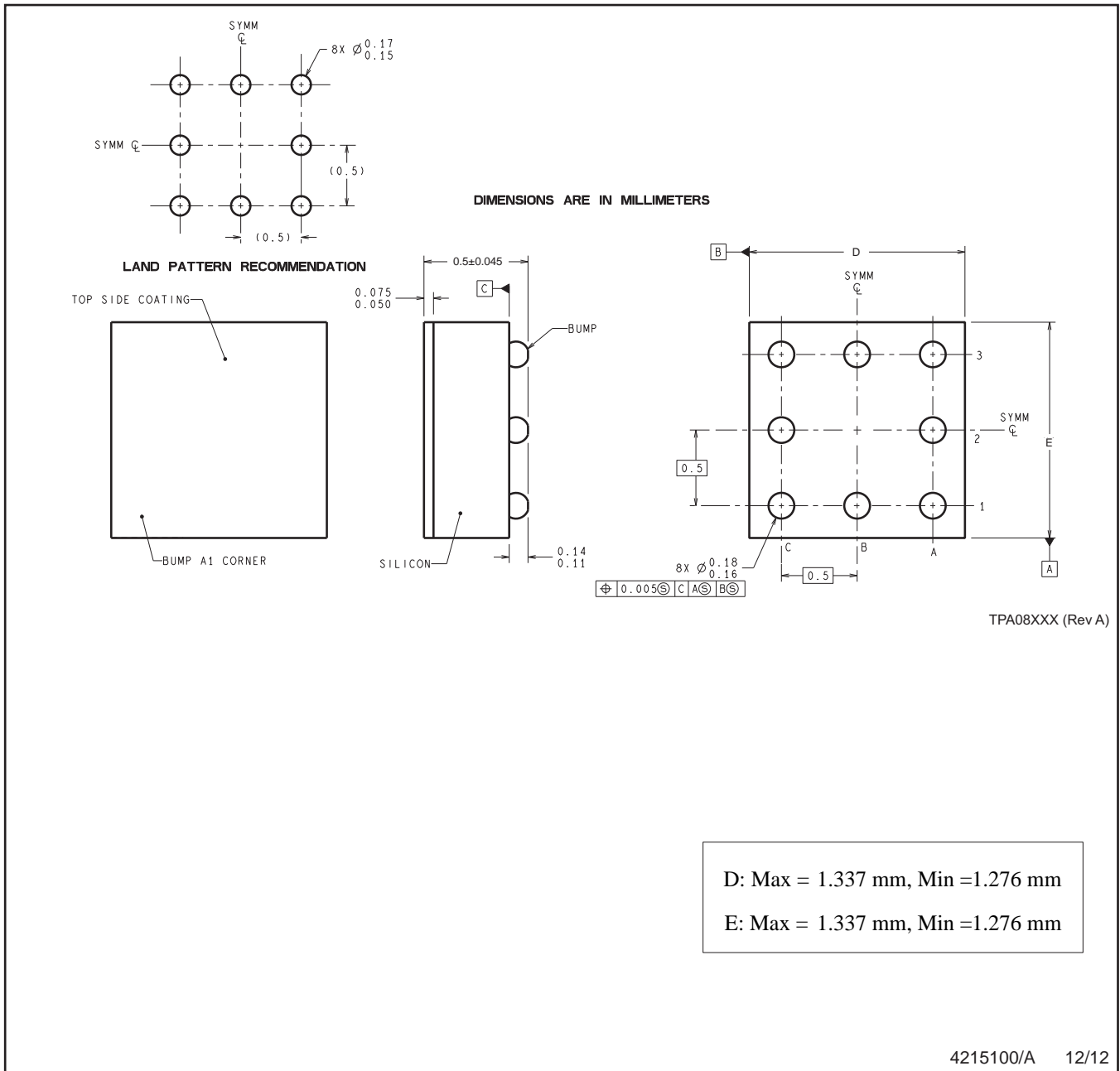

NOTES: A. All linear dimensions are in millimeters. Dimensioning and tolerancing per ASME Y14.5M-1994.
 B. This drawing is subject to change without notice.

IMPORTANT NOTICE

Texas Instruments Incorporated and its subsidiaries (TI) reserve the right to make corrections, enhancements, improvements and other changes to its semiconductor products and services per JESD46, latest issue, and to discontinue any product or service per JESD48, latest issue. Buyers should obtain the latest relevant information before placing orders and should verify that such information is current and complete. All semiconductor products (also referred to herein as "components") are sold subject to TI's terms and conditions of sale supplied at the time of order acknowledgment.

TI warrants performance of its components to the specifications applicable at the time of sale, in accordance with the warranty in TI's terms and conditions of sale of semiconductor products. Testing and other quality control techniques are used to the extent TI deems necessary to support this warranty. Except where mandated by applicable law, testing of all parameters of each component is not necessarily performed.

TI assumes no liability for applications assistance or the design of Buyers' products. Buyers are responsible for their products and applications using TI components. To minimize the risks associated with Buyers' products and applications, Buyers should provide adequate design and operating safeguards.

TI does not warrant or represent that any license, either express or implied, is granted under any patent right, copyright, mask work right, or other intellectual property right relating to any combination, machine, or process in which TI components or services are used. Information published by TI regarding third-party products or services does not constitute a license to use such products or services or a warranty or endorsement thereof. Use of such information may require a license from a third party under the patents or other intellectual property of the third party, or a license from TI under the patents or other intellectual property of TI.

Reproduction of significant portions of TI information in TI data books or data sheets is permissible only if reproduction is without alteration and is accompanied by all associated warranties, conditions, limitations, and notices. TI is not responsible or liable for such altered documentation. Information of third parties may be subject to additional restrictions.

Resale of TI components or services with statements different from or beyond the parameters stated by TI for that component or service voids all express and any implied warranties for the associated TI component or service and is an unfair and deceptive business practice. TI is not responsible or liable for any such statements.

Buyer acknowledges and agrees that it is solely responsible for compliance with all legal, regulatory and safety-related requirements concerning its products, and any use of TI components in its applications, notwithstanding any applications-related information or support that may be provided by TI. Buyer represents and agrees that it has all the necessary expertise to create and implement safeguards which anticipate dangerous consequences of failures, monitor failures and their consequences, lessen the likelihood of failures that might cause harm and take appropriate remedial actions. Buyer will fully indemnify TI and its representatives against any damages arising out of the use of any TI components in safety-critical applications.

In some cases, TI components may be promoted specifically to facilitate safety-related applications. With such components, TI's goal is to help enable customers to design and create their own end-product solutions that meet applicable functional safety standards and requirements. Nonetheless, such components are subject to these terms.

No TI components are authorized for use in FDA Class III (or similar life-critical medical equipment) unless authorized officers of the parties have executed a special agreement specifically governing such use.

Only those TI components which TI has specifically designated as military grade or "enhanced plastic" are designed and intended for use in military/aerospace applications or environments. Buyer acknowledges and agrees that any military or aerospace use of TI components which have **not** been so designated is solely at the Buyer's risk, and that Buyer is solely responsible for compliance with all legal and regulatory requirements in connection with such use.

TI has specifically designated certain components as meeting ISO/TS16949 requirements, mainly for automotive use. In any case of use of non-designated products, TI will not be responsible for any failure to meet ISO/TS16949.

Products

Audio	www.ti.com/audio
Amplifiers	amplifier.ti.com
Data Converters	dataconverter.ti.com
DLP® Products	www.dlp.com
DSP	dsp.ti.com
Clocks and Timers	www.ti.com/clocks
Interface	interface.ti.com
Logic	logic.ti.com
Power Mgmt	power.ti.com
Microcontrollers	microcontroller.ti.com
RFID	www.ti-rfid.com
OMAP Applications Processors	www.ti.com/omap
Wireless Connectivity	www.ti.com/wirelessconnectivity

Applications

Automotive and Transportation	www.ti.com/automotive
Communications and Telecom	www.ti.com/communications
Computers and Peripherals	www.ti.com/computers
Consumer Electronics	www.ti.com/consumer-apps
Energy and Lighting	www.ti.com/energy
Industrial	www.ti.com/industrial
Medical	www.ti.com/medical
Security	www.ti.com/security
Space, Avionics and Defense	www.ti.com/space-avionics-defense
Video and Imaging	www.ti.com/video

TI E2E Community

e2e.ti.com