

# MICRO SWITCH

FREEPORT ILLINOIS, U.S.A  
A DIVISION OF HONEYWELL

FED. MFG. CODE 91929

# ACTUATOR-SWITCH

CATALOG LISTING  
**8AS153**

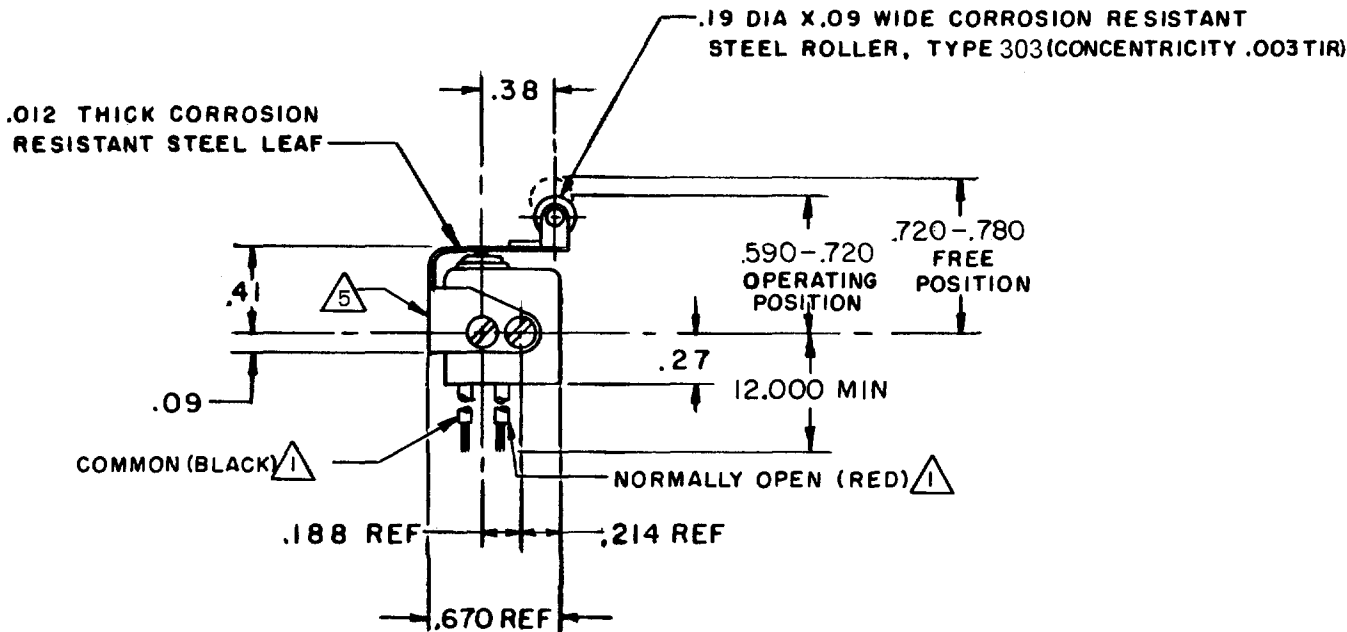
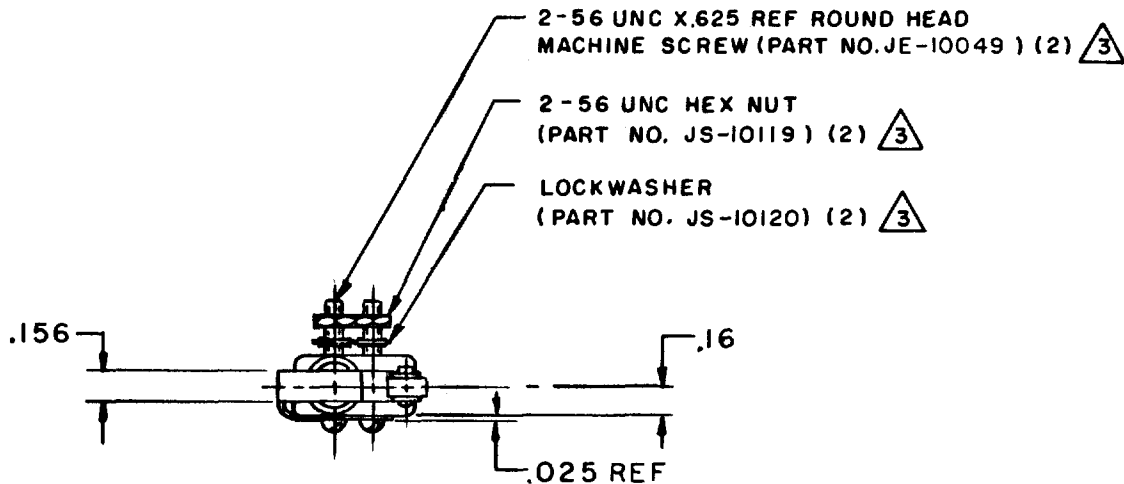

**NOTE -**

- $\triangle 1$  - (2) NO. 22 WIRE LEAD PER MIL-W-22759/11 EMBEDDED IN EPOXY CASTING RESIN
- 2 - UNIT INCLUDES CATALOG LISTING 14XE12 BASIC SWITCH
- $\triangle 3$  - CORROSION RESISTANT STEEL HARDWARE
- 4 - SLIGHT ROTATION BETWEEN BASIC AND ACTUATOR MAY BE NECESSARY TO OBTAIN OPERATING POSITION
- $\triangle 5$  - CATALOG LISTING PERMANENT MARKED ON ACTUATOR

THIS DRAWING COVERS A PROPRIETARY ITEM AND IS THE PROPERTY OF MICRO SWITCH, A DIVISION OF HONEYWELL. THIS DRAWING IS NOT TO BE COPIED OR USED WITHOUT THE APPROVAL OF MICRO SWITCH.

**CHARACTERISTICS**

OPERATING FORCE - - - - 21 OZ MAX

RELEASE FORCE - - - - - 2 OZ MIN

DIFFERENTIAL TRAVEL - - - .018 MAX

OVERTRAVEL - - - - - .009 MIN

**ELECTRICAL DATA**

CONTACT ARRANGEMENT  
S P N O

**SCALE FULL**

DO NOT SCALE PRINT

UNLESS OTHERWISE NOTED  
DIMENSIONS ARE IN INCHES

**TOLERANCES ARE:**

ONE PLACE	(.0)	$\pm .030$
TWO PLACE	(.00)	$\pm .015$
THREE PLACE	(.000)	$\pm .005$
ANGLES		$\pm .005$

WEIGHT

8AS153

M

DRAWING NUMBER

9

ISSUE

REVISIONS

A	NEW DWG	MBF	21 JUN 67
B	ETS	DMW	3 AUG 67
C	PR-729	GCH	24 MAY 69
D	CO26025	RER	13 JUN 69
E	CO28538	RER	FEB 71
F	CO33008	KPK	7 JAN 74
G	CO-84678	CSL	21 APR 97
H	0015428	SPK	14 SEP 05

FORMTEK

DRAWN

REPLACES

PR-729

14SEP05

RJ

CHECK

GCH

21 JUN 67

DMW

3 AUG 67

GCH

24 MAY 69

RER

13 JUN 69

RER

FEB 71

KPK

7 JAN 74

CO-

84678

CSL

21 APR 97

0015428

SPK

14 SEP 05

CHECK

LSD

21 JUN 67

MBF