

HONEYWELL

See full Datasheet below...

onlinecomponents.com
THE ONLINE DISTRIBUTOR OF ELECTRONIC COMPONENTS

BUY NOW

 **MASTER**TM
E L E C T R O N I C S

BUY NOW

masterelectronics.com & onlinecomponents.com
are **authorized** e-commerce distributors
of electronic components.

ASDXL DO Series

Microstructure Pressure Sensors

0 in to ± 5 in H₂O, 0 in to 10 in H₂O, 0 in to ± 10 in H₂O

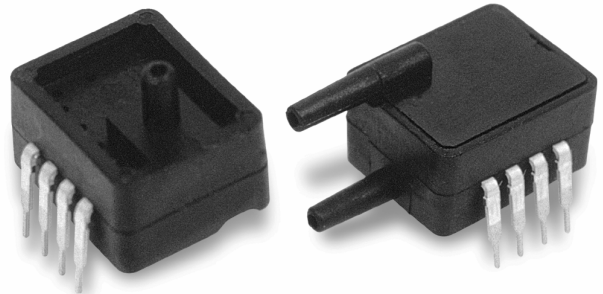

DESCRIPTION

The ASDXL DO Series pressure sensors are fully calibrated and temperature compensated with on-board Application Specific Integrated Circuitry (ASIC). This ASDXL DO sensor is in a DIP format (Dual In-line Package) and provides digital correction of sensor offset, sensitivity, temperature coefficients and non-linearity. The ASDXL DO Series has 12-bit I²C compatible protocol interface which allows easy interfacing to most commonly used microcontrollers and microprocessors.

The 2-wire I²C interface has a Serial Clock Line input (SCL) and serial digital output data line. The output of the device is a corrected pressure value in hexadecimal format with 12-bit accuracy (unsigned) and not ratiometric to the supply voltage.

FEATURES

- Available in differential and gage packages
- Calibrated and temperature compensated output
- 12-bit digital output (I²C compatible protocol)
- Pressure ranges from 0 in to ± 5 in H₂O, 10 in H₂O, ± 10 in H₂O
- Response time of 8 ms
- DIP package
- ASIC-enhanced output

All ASDXL DO sensors are accurate to within ± 2.5 % Full Scale Span (FSS) and are intended for use with non-corrosive, non-ionic working fluids such as air and dry gases. (Contact factory for media compatibility on G2/D4 packages.)

This series is designed and manufactured in accordance with ISO 9001 standards and is compliant with the WEEE and RoHS directives.

POTENTIAL APPLICATIONS

- Medical equipment
- HVAC controls
- Pneumatic controls

ASDXL DO Series

0 in to ±5 in H₂O, 0 in to 10 in H₂O, 0 in to ±10 in H₂O

GENERAL SPECIFICATIONS

Characteristic	Parameter	Characteristic	Parameter
Supply voltage (Vs)	4.75 Vdc to 5.25 Vdc	Lead soldering temperature	4 s at 250 °C [482 °F]
Maximum supply voltage	6.50 Vdc max.	Vibration	10 g at 20 Hz to 2000 Hz
Current consumption	6 mA typ.	Shock	100 g for 11 ms
Output current - sink	2 mA max.	Life	1 million cycles min.
Output current - source	2 mA max.	Position sensitivity	50 μV/V/g typical

ENVIRONMENTAL SPECIFICATIONS

Characteristic	Range
Compensated	0 °C to 85 °C [32 °F to 185 °F]
Operating	-20 °C to 105 °C [-4 °F to 221 °F]
Storage	-40 °C to 125 °C [-40 °F to 257 °F]

PRESSURE RANGE SPECIFICATIONS

Listing	Pressure Range	Burst Pressure ⁽¹⁾
ASDXL05	0 in to ±5 in H ₂ O	3 PSI
ASDXL10	0 in to 10 in H ₂ O 0 in to ±10 H ₂ O	3 PSI

PERFORMANCE CHARACTERISTICS 4D DO ^(2,3)

Characteristic	Min.	Typ.(5)	Max.	Unit
Full scale span (FSS) ^(4,5)	—	CCC	—	counts hex
Zero pressure offset ⁽⁵⁾	07AE	0800	0851	counts hex
Output at full scale pressure (P2) ^(5,6)	0E14	0E66	0EB8	counts hex
Output at full scale pressure (P1) ^(5,6)	0147	019A	01EB	counts hex
Accuracy ⁽⁷⁾	—	—	±2.5	% FSS
Output resolution	—	12	—	bit
Response time ⁽⁸⁾	—	8	11	ms

PERFORMANCE CHARACTERISTICS 4R DO ^(2,3)

Characteristic	Min.	Typ.	Max.	Unit
Full scale span (FSS) ^(4,5)	—	CCC	—	counts hex
Zero pressure offset ⁽⁵⁾	0147	019A	01EB	counts hex
Output at full scale pressure ⁽⁵⁾	0E14	0E66	0EB8	counts hex
Accuracy ⁽⁷⁾	—	—	±2.5	% FSS
Output resolution	—	12	—	bit
Response time ⁽⁸⁾	—	8	11	ms

Notes:

- If burst pressure is exceeded, even momentarily, the package may leak or the pressure sensing die may fracture.
- Reference conditions (unless otherwise noted): supply voltage, V_S=5.0 ±0.01 Vdc, T_a=25 °C [77 °F].
- Read operation: *Start, Slave Address, R/W=1, Data Byte 1 (MSB), Ackn Bit, Data Byte 2 (LSB)*. The output is corrected pressure as unsigned 12 bits. Slave Address is F0h. Acknowledge Bit - pull data line LOW, master generates an extra clock pulse for this purpose.
- Span is the algebraic difference between the output voltage at the specified pressure and the output at zero pressure.
- Output is non-ratiometric within the supply voltage range (Vs).
- Output of the device when maximum positive pressure is applied on the backside (P2) or the front side (P1) of the sensing element.
- Accuracy is the combined errors from offset and span calibration, linearity, pressure hysteresis, and temperature effects. Calibration errors include the deviation of offset and full scale from nominal values. Linearity is the measured deviation based on a straight line. Hysteresis is the maximum output difference at any point within the operating pressure range for increasing and decreasing pressure and temperature.
- Response time for 0 PSI to full scale pressure step change, 10% to 90% rise time.
- 220 nF capacitor required between +Vs and GND.

ELECTRICAL CONNECTIONS ^(1,2,3)

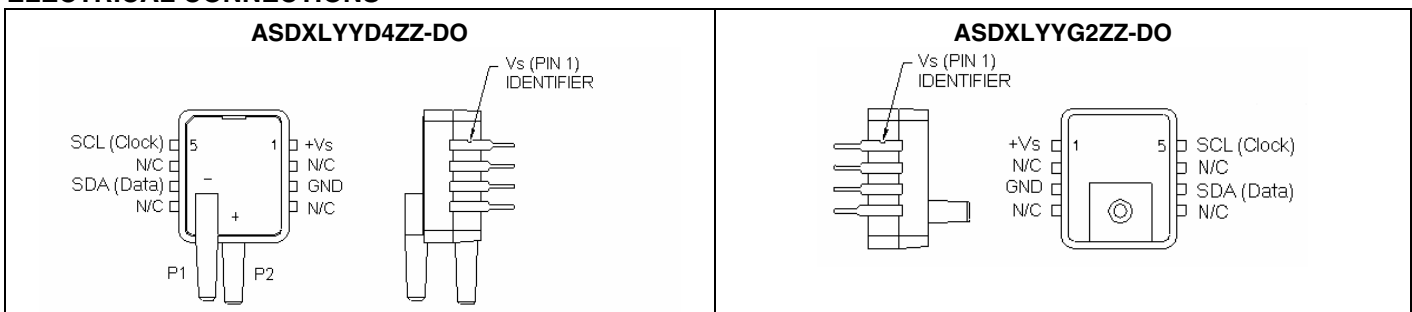

Notes:

- N/C means no connection. Connecting to ground or other potential may damage sensors.
- Capacitor 220 nF required between +Vs and GND.
- The sensor is not reverse polarity protected. Incorrect application of excitation voltage or ground to the wrong pin can cause electrical failure. Application of supply voltage above the maximum can cause electrical failure.

Microstructure Pressure Sensors

DIMENSIONS (For reference only, mm/in.)

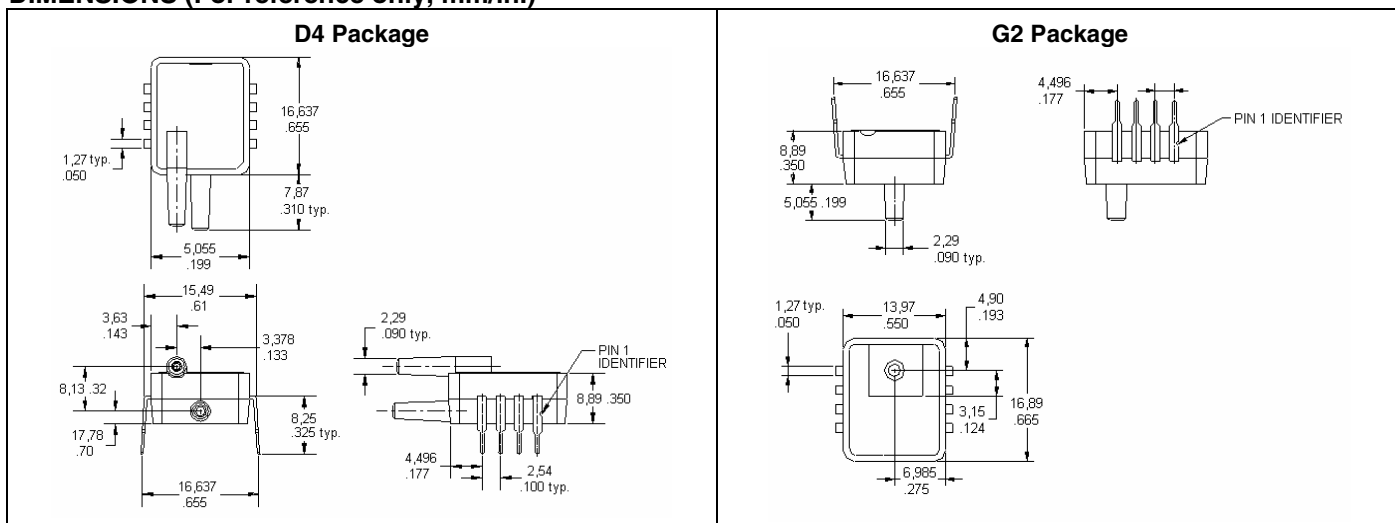

SERIAL INTERFACE PARAMETERS

Parameter	Symbol	Condition	Min.	Typ.	Max.	Unit
Input high level	VIH	—	4.5	—	1	Vs
Input low level	VIL	—	0	—	0.5	Vs
Output low level	VOL	open drain IOL = -4 mA	—	—	0.1	Vs
Pull up current	VOH	pin SCL and SDA	5	—	20	µA
Load capacitance SDA	CLSDA	—	—	—	400	pF
SCL clock frequency	fSCL	—	—	—	100	kHz
Bus free time between STOP and START condition	tBUF	—	4.7	—	—	µs
Hold time (repeated) START condition	tHD, STA	to first clock pulse	4.0	—	—	µs
LOW period of SCL	tLOW	—	4.7	—	—	µs
High period of SCL	tHIGH	—	4.0	—	—	µs
Setup time repeated START condition	tSU, STA	—	4.7	—	—	µs
Data hold time	tHD, DAT	—	0	—	—	ns
Data setup time	tSU, DAT	—	250	—	—	ns
Rise time of both SDA and SCL	tR	—	—	—	300	ns
Fall time of both SDA and SCL	—	—	—	—	300	ns
Setup time for STOP condition	tSU, STO	—	4	—	—	µs
Input filter spike suppression	tsp	spikes on SDA or SCL of that length are suppressed	—	—	50	µs

SERIAL INTERFACE TIMING CHARACTERISTICS BLOCK DIAGRAM

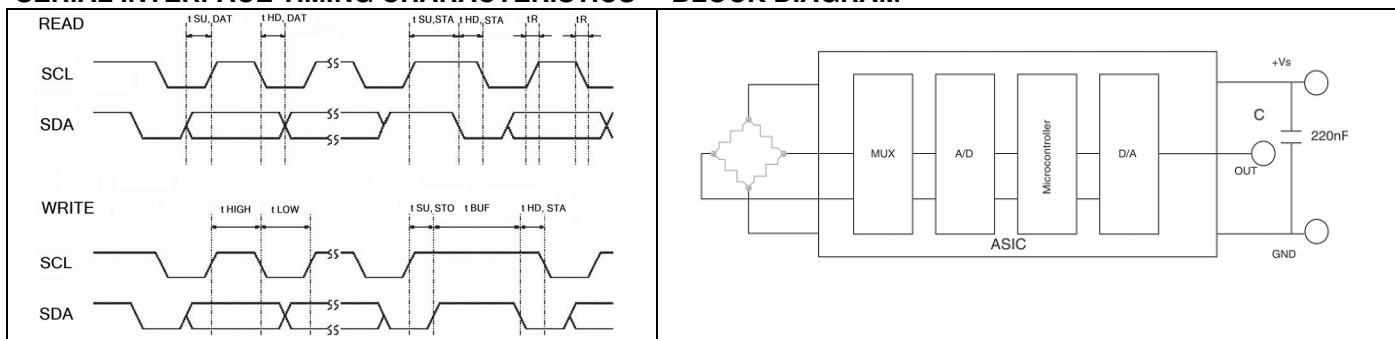

ORDERING INFORMATION

Pressure Range	Gage	Differential	Bidirectional
0 in to ± 5 in H ₂ O	–	–	ASDXL05D44D-DO
0 in to 10 in H ₂ O	ASDXL10G24R-DO	ASDXL10D44R-DO	–
0 in to ± 10 in H ₂ O	–	–	ASDXL10D44D-DO

WARNING

PERSONAL INJURY

DO NOT USE these products as safety or emergency stop devices or in any other application where failure of the product could result in personal injury.

Failure to comply with these instructions could result in death or serious injury.

WARRANTY/REMEDY

Honeywell warrants goods of its manufacture as being free of defective materials and faulty workmanship. Honeywell's standard product warranty applies unless agreed to otherwise by Honeywell in writing; please refer to your order acknowledgement or consult your local sales office for specific warranty details. If warranted goods are returned to Honeywell during the period of coverage, Honeywell will repair or replace, at its option, without charge those items it finds defective. **The foregoing is buyer's sole remedy and is in lieu of all other warranties, expressed or implied, including those of merchantability and fitness for a particular purpose. In no event shall Honeywell be liable for consequential, special, or indirect damages.**

While we provide application assistance personally, through our literature and the Honeywell web site, it is up to the customer to determine the suitability of the product in the application.

Specifications may change without notice. The information we supply is believed to be accurate and reliable as of this printing. However, we assume no responsibility for its use.

WARNING

MISUSE OF DOCUMENTATION

- The information presented in this product sheet is for reference only. Do not use this document as a product installation guide.
- Complete installation, operation, and maintenance information is provided in the instructions supplied with each product.

Failure to comply with these instructions could result in death or serious injury.

SALES AND SERVICE

Honeywell serves its customers through a worldwide network of sales offices, representatives and distributors. For application assistance, current specifications, pricing or name of the nearest Authorized Distributor, contact your local sales office or:

E-mail: info.sc@honeywell.com

Internet: www.honeywell.com/sensing

Phone and Fax:

Asia Pacific +65 6355-2828
+65 6445-3033 Fax
Europe +44 (0) 1698 481481
+44 (0) 1698 481676 Fax
Latin America +1-305-805-8188
+1-305-883-8257 Fax
USA/Canada +1-800-537-6945
+1-815-235-6847
+1-815-235-6545 Fax

Automation and Control Solutions

Sensing and Control

Honeywell

1985 Douglas Drive North

Minneapolis, MN 55422

www.honeywell.com/sensing

008140-2-EN IL50 GLO Printed in USA
June 2006

Copyright © 2006 Honeywell International Inc. All rights reserved.

Honeywell