

HONEYWELL

See full Datasheet below...

onlinecomponents.com
THE ONLINE DISTRIBUTOR OF ELECTRONIC COMPONENTS

BUY NOW

 **MASTER**TM
E L E C T R O N I C S

BUY NOW

masterelectronics.com & onlinecomponents.com
are **authorized** e-commerce distributors
of electronic components.

Microstructure Pressure Sensors

0 psi to 1 psi through 0 psi to 100 psi

ASDX Series

FEATURES

- ASIC enhanced output
- Wide compensated temperature range 0 °C to 85 °C [32 °F to 185 °F]
- Available in absolute, differential and gage types
- Pressure ranges from 0 psi to 1 psi through 0 psi to 100 psi
- Accuracy ± 2 % max. Volts Full Scale
- Quantization step of 3 mV
- Response time 8 ms

TYPICAL APPLICATIONS

- Flow calibrators
- Ventilation and air flow monitors
- Gas flow instrumentation
- Dialysis equipment
- Sleep apnea monitoring and therapy equipment
- Barometry
- HVAC controls
- Pneumatic controls

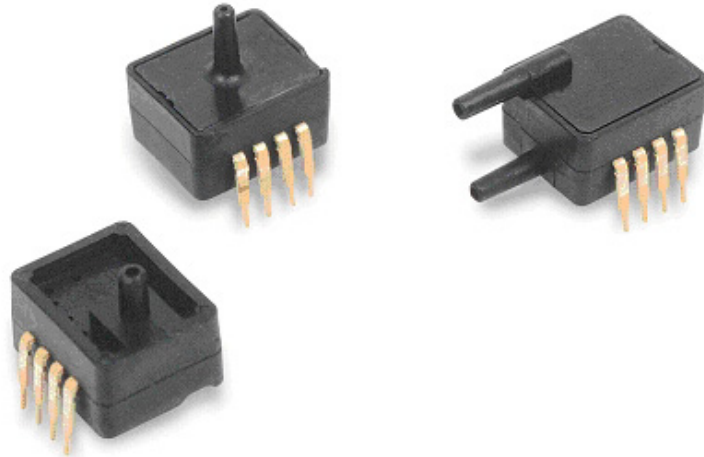

The ASDX series is an amplified version of Honeywell's proven performer and industry leading SDX series sensor. The amplified ASDX sensor's footprint is slightly larger than the SDX but it offers a high level output (4.0 Vdc span) on a very cost-effective basis. This series is fully calibrated and temperature compensated with on-board Application Specific Integrated Circuitry (ASIC). They are intended for use with non-corrosive, non-ionic working fluids; such as air and dry gases.

Sensors are available to measure absolute, differential, and gage pressures. The absolute devices have an internal vacuum reference and an output voltage proportional to absolute pressure. Differential devices allow application of pressure to either side of the sensing diaphragm and can be used for gauge or differential measurements.

All ASDX devices are accurate to within ± 2.0 % full scale, designed for operation from a single 5.0 Vdc supply and are manufactured in accordance with ISO 9001 standards.

⚠ WARNING

PERSONAL INJURY

DO NOT USE these products as safety or emergency stop devices or in any other application where failure of the product could result in personal injury.

Failure to comply with these instructions could result in death or serious injury.

⚠ WARNING

MISUSE OF DOCUMENTATION

- The information presented in this product sheet is for reference only. Do not use this document as a product installation guide.
- Complete installation, operation, and maintenance information is provided in the instructions supplied with each product.

Failure to comply with these instructions could result in death or serious injury.

Microstructure Pressure Sensors

0 psi to 1 psi through 0 psi to 100 psi

ASDX Series

BLOCK DIAGRAM

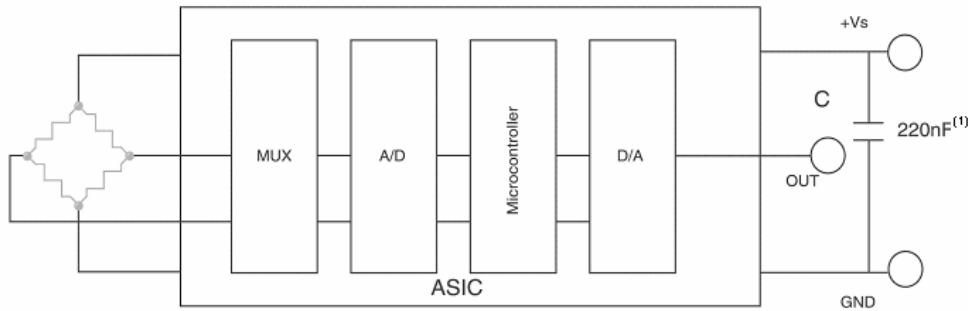

ELECTRICAL CONNECTIONS⁽²⁾ PIN OUT

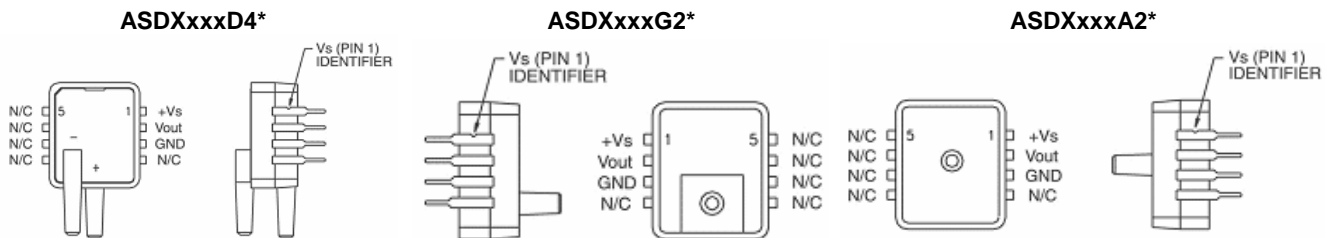

* N/C means no connection, connecting to ground will damage to sensor.

SPECIFICATIONS (Maximum Ratings)

Supply Voltage (Vs)*	4.75 Vdc to 5.25 Vdc
Maximum Supply Voltage*	6.50 Vdc (max.)
Consumption Current	6 mA (typ.)
Output Current - Sink	2 mA (max.)
Output Current - Source	2 mA (max.)
Lead Temperature	2 Sec to 4 Sec @ 250 °C [482 °F]

*Note: The sensor is not reverse polarity protected. Incorrect application of excitation voltage or ground to the wrong pin can cause electrical failure. Application of supply voltage above the maximum can cause electrical failure.

ENVIRONMENTAL SPECIFICATIONS (ALL DEVICES)

Temperature Ranges:	
Compensated:	0 °C to 85 °C [32 °F to 185 °F]
Operating:	-20 °C to 105 °C [-4 °F to 221 °F]
Storage:	-40 °C to 125 °C [-40 °F to 257 °F]
Vibration:	10 g at 20 Hz to 2000 Hz
Shock:	50 g for 11 ms
Life:	1 million cycles minimum

PRESSURE RANGE SPECIFICATIONS

Part No.	Pressure Range	Burst Pressure ⁽³⁾	Sensitivity
ASDX001	0 psi to 1 psi	5 psi	4.00 V/psi
ASDX005	0 psi to 5 psi	20 psi	0.80 V/psi
ASDX015	0 psi to 15 psi	30 psi	0.267 V/psi
ASDX030	0 psi to 30 psi	60 psi	0.133 V/psi
ASDX100	0 psi to 100 psi	150 psi	0.040 V/psi

Microstructure Pressure Sensors

0 psi to 1 psi through 0 psi to 100 psi

ASDX Series

PERFORMANCE SPECIFICATIONS⁽⁴⁾

Characteristic	Symbol	Min.	Typ.	Max.	Units
Zero Pressure Offset	V _{off}	0.420	0.500	0.580	Vdc
Full Scale Span ⁽⁵⁾	V _{fss}		4.00		Vdc
Output at FS Pressure	V _{fso}	4.420	4.500	4.580	Vdc
Accuracy ⁽⁶⁾	–	–	–	±2.0	% V _{fs}
Response Time ⁽⁷⁾		–	8	–	ms
Quantization Step ⁽⁸⁾		–	3	–	mV

SPECIFICATION NOTES

- Note 1: Capacitor 220 nF required between +Vs and GND pin.
 Note 2: Pins 4, 5, 6, 7 and 8 are internal device connections and should not be connected to external circuitry or ground.
 Note 3: If maximum burst pressure is exceeded, even momentarily, the package may leak or burst, or the pressure sensing die may fracture.
 Note 4: Reference Conditions (unless otherwise noted): Supply voltage, V_s=5.0 ± 0.01 Vdc; T_a=25 °C [77 °F]. Output is ratiometric within the supply voltage range (Vs).
 Note 5: Span is the algebraic difference between the output voltage at the specified pressure and the output at zero pressure. Span is ratiometric to the supply voltage.
 Note 6: Accuracy is the combined errors from offset and span calibration, linearity, pressure hysteresis, and temperature effects. Linearity is the measured deviation based on a straight line. Hysteresis is the maximum output difference at any point within the operating pressure range for increasing and decreasing pressure. Calibration errors include the deviation of offset and full scale from nominal values.
 Note 7: Response time for a 0 psi to full-scale pressure step change, 10 % to 90 % rise time.
 Note 8: The smallest change in the output voltage, given any change in pressure.

PRESSURE TRANSDUCER PERFORMANCE CHARACTERISTICS

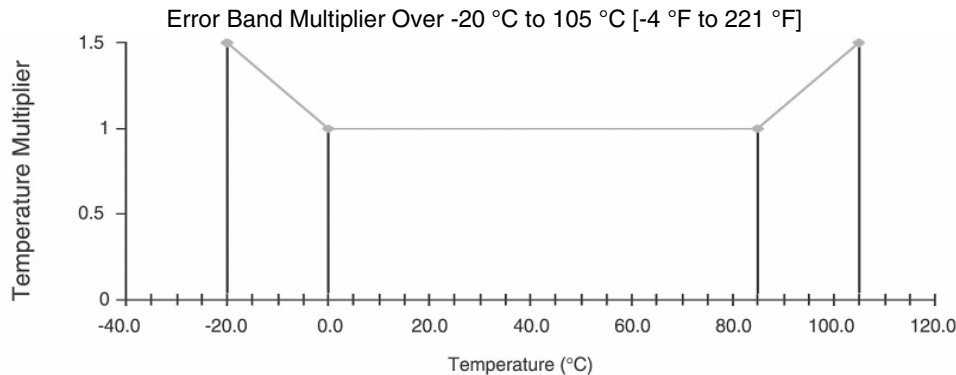

ORDERING INFORMATION - PART NUMBER DESCRIPTION

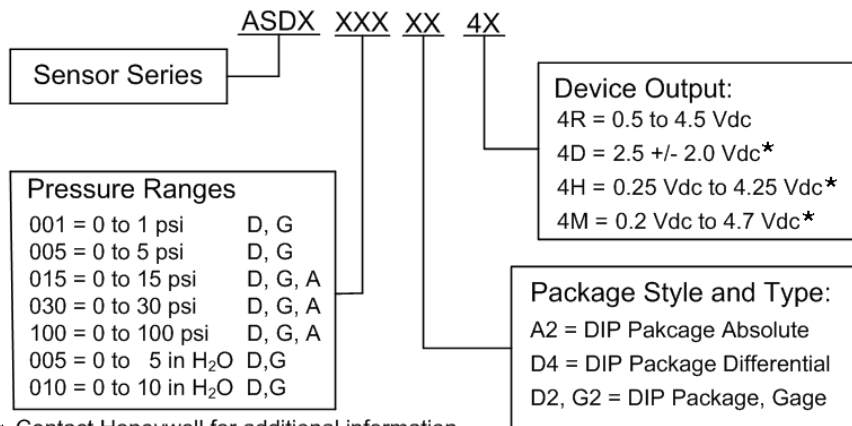

For example:

Part #ASDX015A24R=ASDX device 15 psi absolute, A2 Package, 0.5 Vdc to 4.5 Vdc Output

* Contact Honeywell for additional information

Microstructure Pressure Sensors

ASDX Series

0 to 1 psi through 0 to 100 psi

TO ORDER, USE THE FOLLOWING PART NUMBER(S)

Pressure Range	Absolute	Gauge	Differential	Bidirectional
0 psi to 1 psi	—	ASDX001G24R	ASDX001D44R	ASDX001D44D
0 psi to 5 psi	—	ASDX005G24R	ASDX005D44R	ASDX005D44D
0 psi to 15 psi	ASDX015A24R	ASDX015G24R	ASDX015D44R	ASDX015D44D
0 psi to 30 psi	ASDX030A24R	ASDX030G24R	ASDX030D44R	ASDX030D44D
0 psi to 100 psi	ASDX100A24R	ASDX100G24R	ASDX100D44R	ASDX100D44D

DIMENSIONAL DRAWINGS - For Reference Only mm [in]

D4 Package

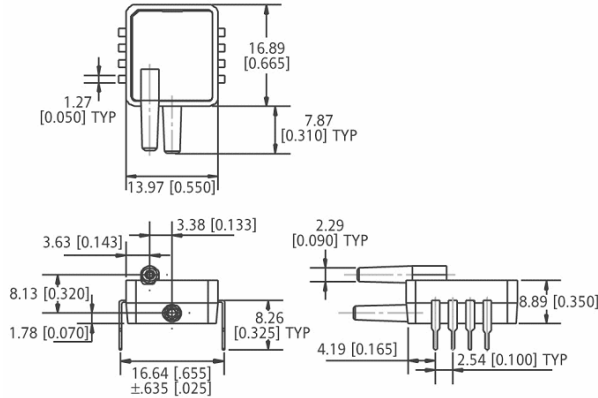

G2 Package

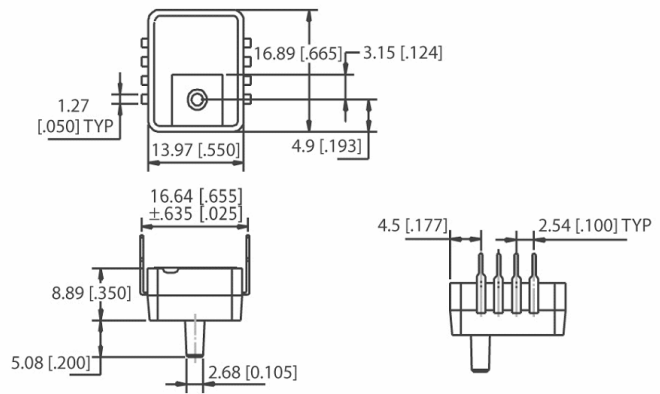

A2 Package

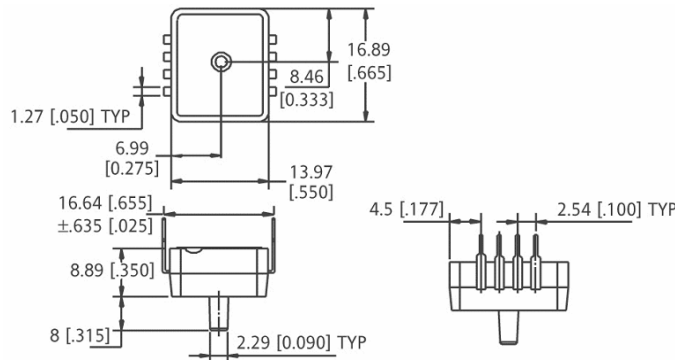

WARRANTY/REMEDY

Honeywell warrants goods of its manufacture as being free of defective materials and faulty workmanship. Contact your local sales office for warranty information. If warranted goods are returned to Honeywell during the period of coverage, Honeywell will repair or replace without charge those items it finds defective. **The foregoing is Buyer's sole remedy and is in lieu of all other warranties, expressed or implied, including those of merchantability and fitness for a particular purpose.**

Specifications may change without notice. The information we supply is believed to be accurate and reliable as of this printing. However, we assume no responsibility for its use.

While we provide application assistance personally, through our literature and the Honeywell web site, it is up to the customer to determine the suitability of the product in the application. For application assistance, current specifications, or name of the nearest Authorized Distributor, contact a nearby sales office. Or call:

1-800-537-6945 USA
1-800-737-3360 Canada
1-815-235-6847 International

FAX
1-815-235-6545 USA

INTERNET
www.honeywell.com/sensing
info.sc@honeywell.com

Honeywell

Sensing and Control
www.honeywell.com/sensing

Honeywell
11 West Spring Street
Freeport, Illinois 61032