



VLT69273X11J

Vehicular 3-Port MIMO Antenna
698-960 MHz/1710-2700 MHz
4900-5900 MHz/GNSS

The TE Connectivity vehicular three-port MIMO antenna covers the 698-960/1710-2700 MHz and 2300-2700/4900-5900 MHz frequency ranges with an added global navigational antenna. Configured with one 3G/4G port, one dual band Wi-Fi port and a third port configured with a GNSS navigational antenna.

Connector options include, but not limited to, SMA male connectors for 3G/4G LTE and GNSS ports with an RPSMA male connector for the Wi-Fi port. The housing incorporates a low-profile, rugged design that meets IP67, EN61373 Shock & Vibration and EN50155 Temperature and Humidity standards. The antenna also features high impact, UVresistant polycarbonate plastic radome available in black or white.

APPLICATION

- FirstNet/Public Safety
- Passenger Fleet
- Commercial Vehicle Fleet
- Rail Transit

ELECTRICAL SPECIFICATIONS

Number of Ports	3G/4G LTE - 1		Wi-Fi - 1	
	698-960	1710-2700	2300-2700	4900-5900
Operating Frequency (MHz)	698-960	1710-2700	2300-2700	4900-5900
Peak Gain - Average* (dBi)	2.0	4.1	4.2	4.9
Peak Gain - Max* (dBi)	2.6	4.7	4.9	6.0
VSWR- Average**	1.4	1.2	1.3	1.2
VSWR- Max**	2.0	2.0	2.0	2.0
Isolation** LTE to WIFI (dB)	-25	-25	-25	-38
Nominal Impedance (Ohms)	50			
Max Power - Ambient 25°C (W)	50			
Polarization	Vertical Linear			
Horizontal Plane 3 dB Beamwidth Port 1	Omnidirectional			

* Measured on 1 ft (30.48 cm) diameter ground plane

** Measured on 1 ft (30.48 cm) diameter ground plane and 17 ft (518 cm) Antenna specification is subjected to change according to the ground plane size

MECHANICAL SPECIFICATIONS

Dimensions - diameter x height - mm (in.)	132 x 75 (5.20 x 2.9)
Weight - kg (lbs)	0.74 (1.63)
Cable Type	LMR*-195 or equivalent
Mounting	P- Mount
Radome and Base Plate Material	PC, UL94 - V0 Rating, UV Stable

ENVIRONMENTAL SPECIFICATIONS

Operating Temperature - °C (°F)	-30 to +70 (-22 to +158)
Storage Temperature - °C (°F)	-40 to +85 (-40 to +185)
Shock and Vibration Tests	EN61373 Compliant
Temperature and Humidity Tests	EN50155 Compliant
Ingress Protection Rating	IP67
Material Substance Compliance	RoHS

CONFIGURATION

PART NUMBER	CABLE LENGTH	CONNECTOR LTE PORT	CONNECTOR WI-FI PORT	COLOR	NAVIGATION
VLT69273B11J-518A	5.18M (17FT)	SMA MALE	RPSMA MALE	BLACK	GNSS
VLT69273W11J-518A	5.18M (17FT)	SMA MALE	RPSMA MALE	WHITE	GNSS

GNSS ANTENNA SPECIFICATIONS

Model Number	VHP69273X22J		
Number of Ports	GNSS- 1		
Frequency Band (MHz)	BEIDOU	GPS	GLONASS
Frequency of Operation (MHz)	1561.098 ± 2.046	1.575.42 ± 1.023	1602.0 ± 5.0
Amplifier Gain (dB)	28 dB ± 3		
Nominal Impedance (Ohms)	50 Ω		
Output VSWR	< 2:1		
DC Voltage	2.5 - 7 VDC		
Current Consumption, mA	8.5 ± 3 (AT 3.0V)		
Input Max Power, dBm	-10		
Out of Band Rejection, dBc	> 80 (698- 960 MHZ)	> 80 (1428- 2700 MHZ)	> 70 (4900- 5800 MHZ)
Working/Storage Temperature	-40°C - +85°C (-40°F - +185°F)		
Connector	SMA-Male		
Cable - Exposed Length	RG174-518.2 cm (17 ft.)		

PACKAGING INFORMATION

PACKAGED DIMENSIONS	CARTON	MASTER CARTON	AIR PALLET	OCEAN PALLET
Number of Antennas	4	8	192	240
Height- mm (in.)	305 (12.0)	305 (12.0)	1363 (53.66)	1668 (65.67)
Length- mm (in.)	525 (20.7)	525 (20.7)	1200 (47.24)	1200 (47.24)
Width- mm (in.)	132 (5.22)	265 (10.4)	800 (31.5)	800 (31.5)
Shipping Weight- kg (lb.)	5.0 (11)	10.1 (22.3)	255 (562)	316 (697)

MECHANICAL DRAWINGS

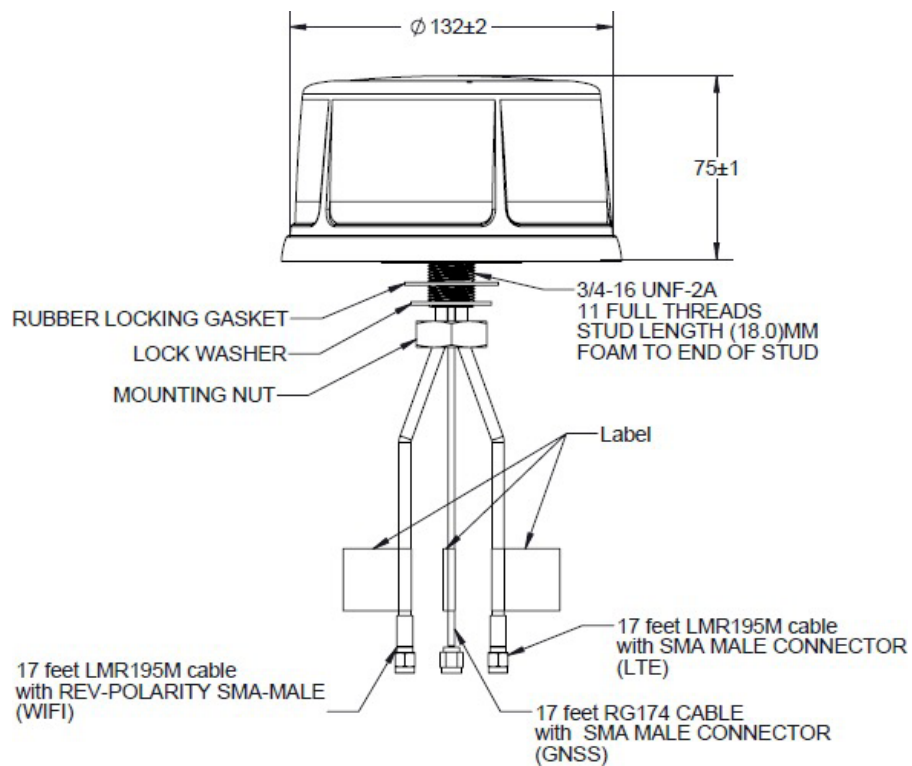

RADIATION PATTERNS- LTE/CELL PORTS

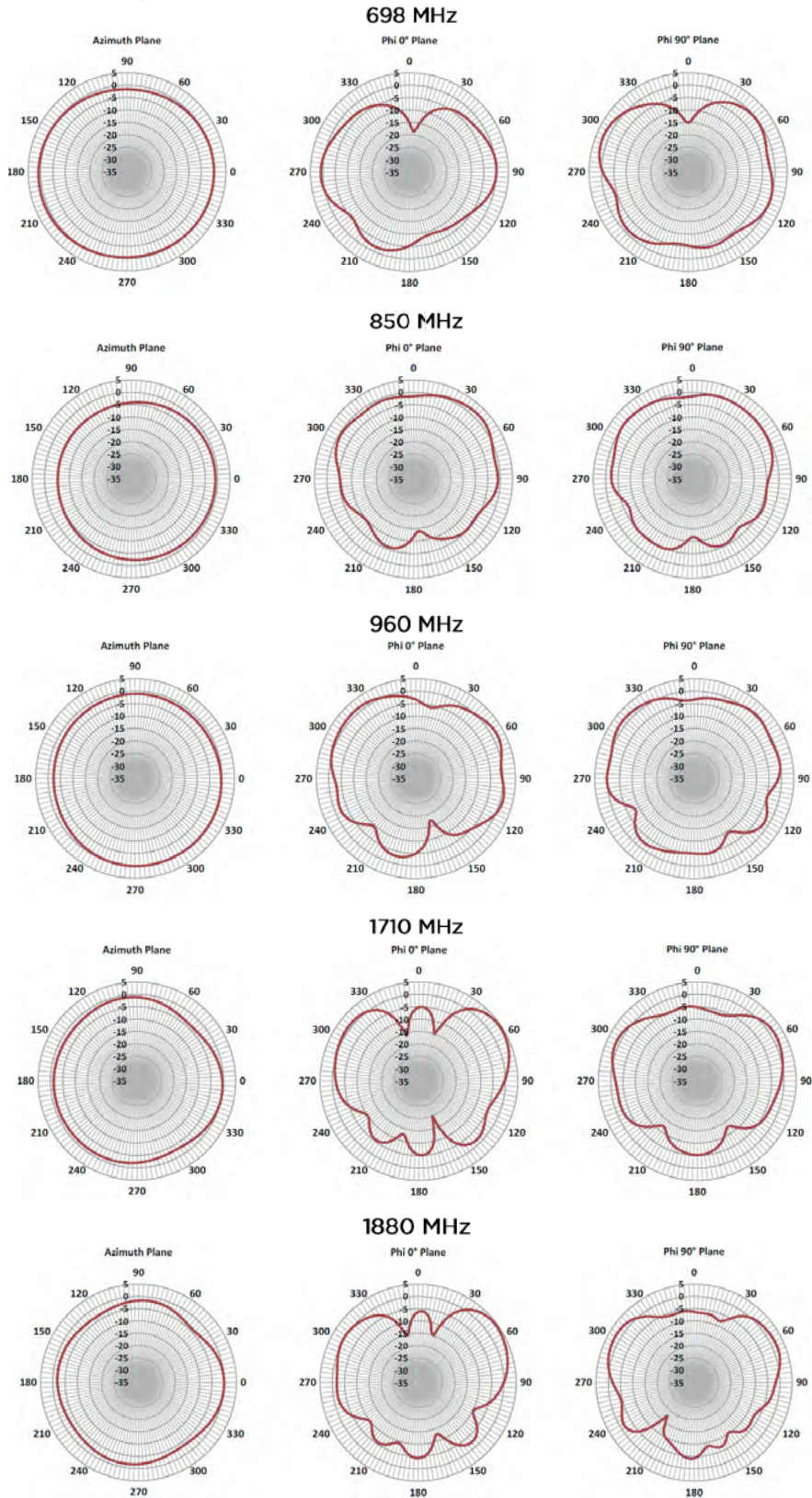

RADIATION PATTERNS- LTE/CELL PORTS

1930 MHz

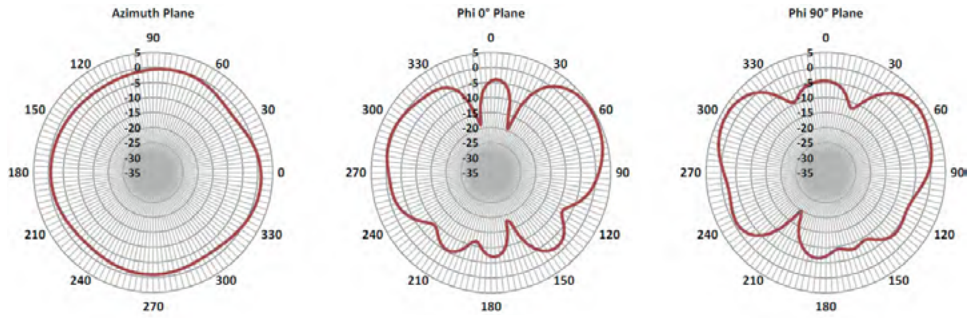

2170 MHz

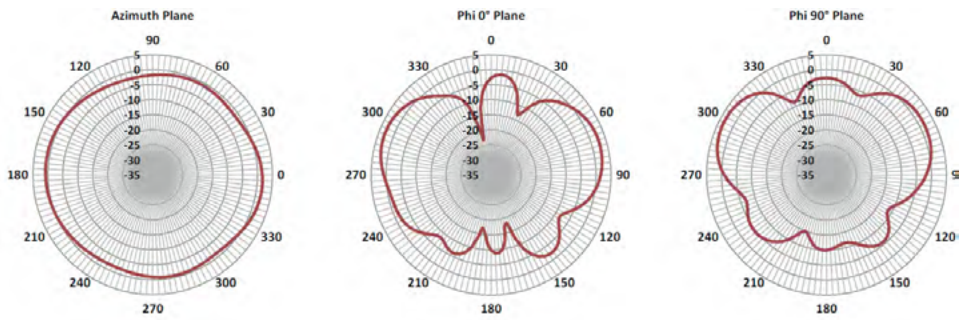

2310 MHz

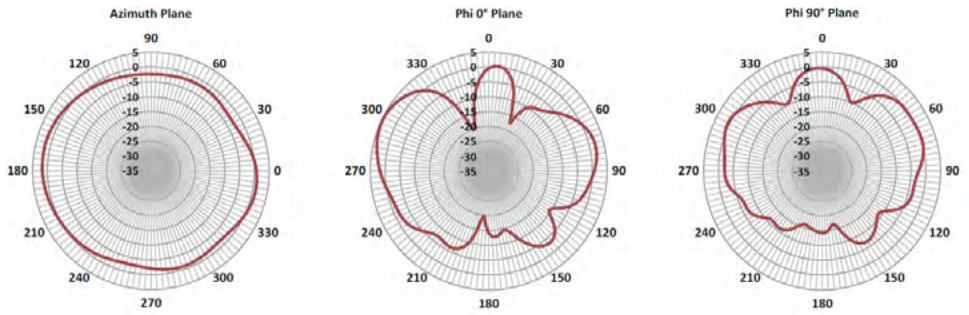

2700 MHz

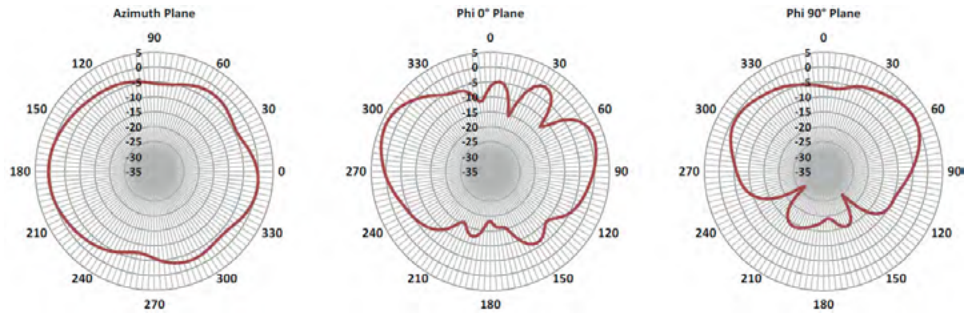

RADIATION PATTERNS- WI-FL PORTS

2400 MHz

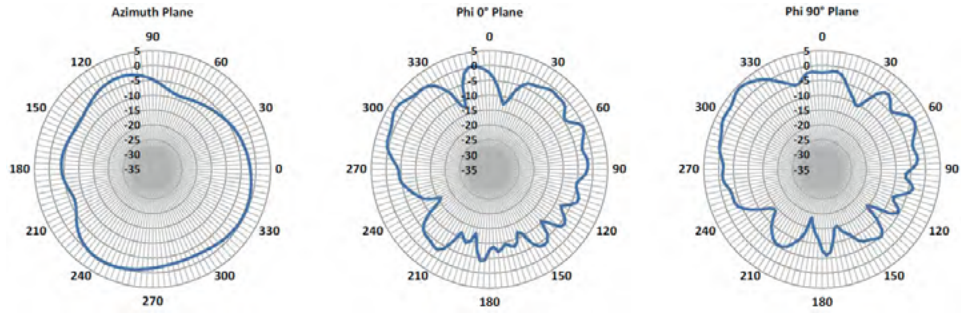

2460 MHz

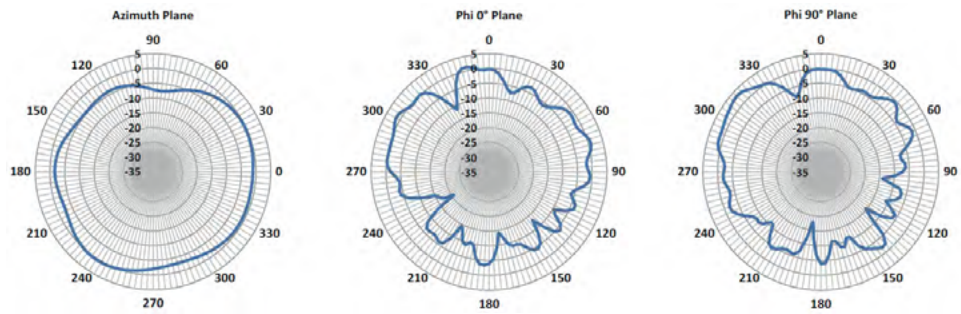

2500 MHz

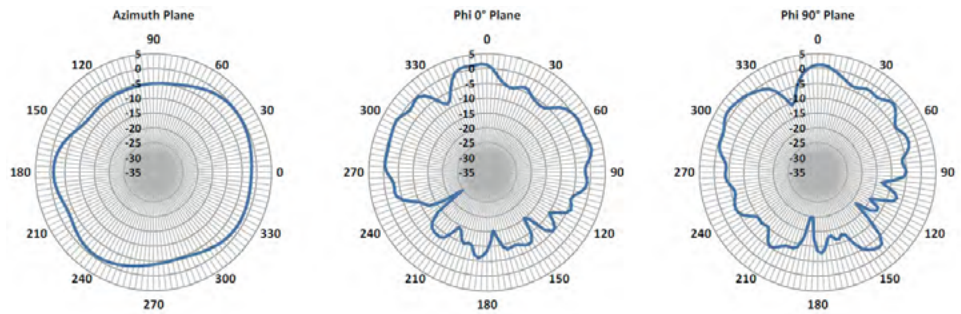

4900 MHz

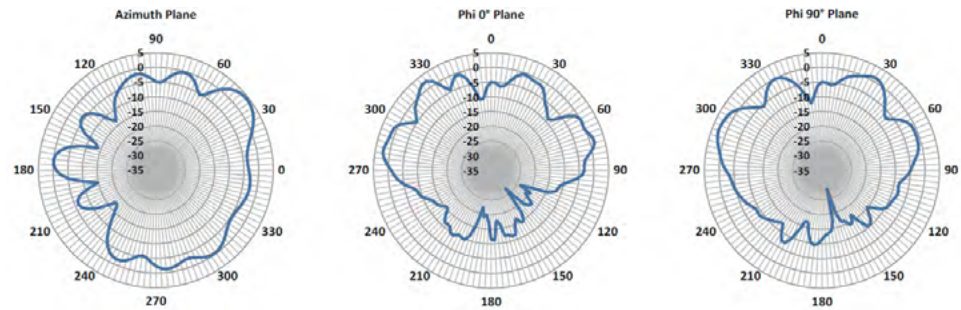

RADIATION PATTERNS- WI-FL PORTS

5470 MHz

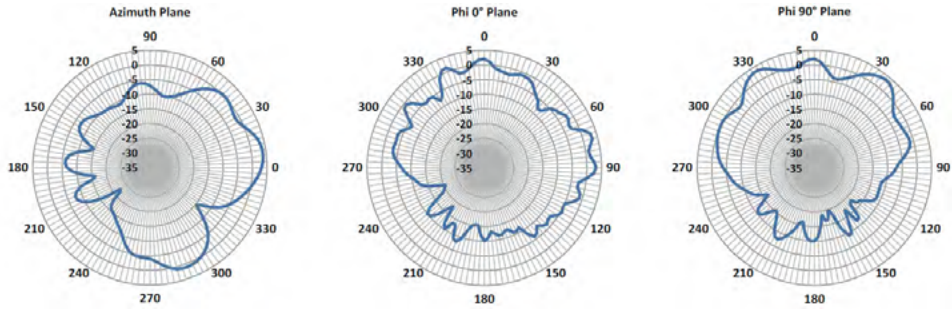

5725 MHz

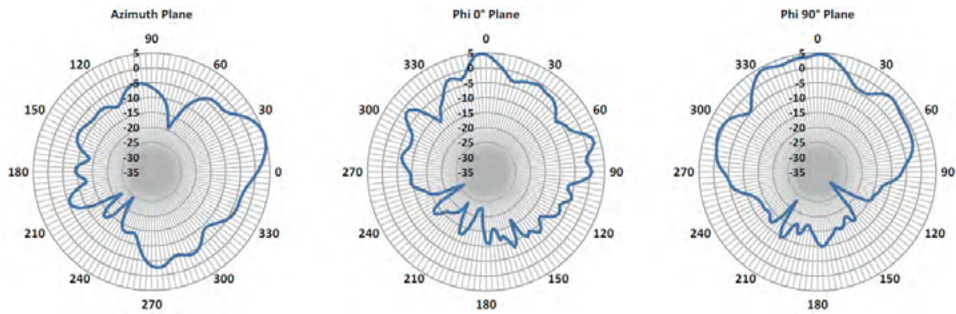

5925 MHz

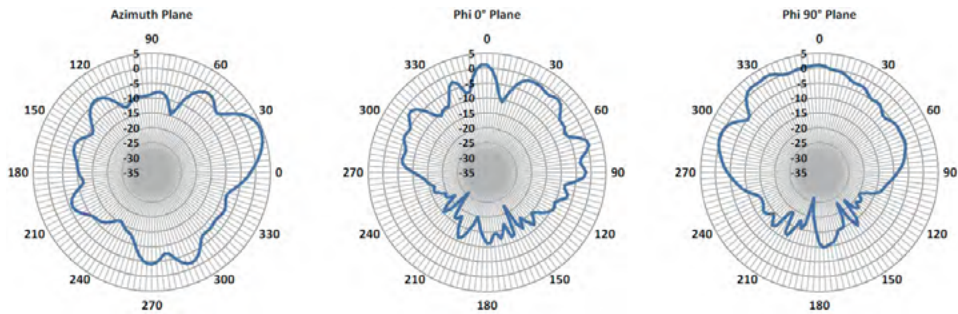

te.com

TE, TE Connectivity, TE connectivity (logo), and EVERY CONNECTION COUNTS are trademarks owned or licensed by the TE Connectivity plc family of companies. Other product names, logos, and company names mentioned herein may be trademarks of their respective owners.

While TE has made every reasonable effort to ensure the accuracy of the information in this document, TE does not guarantee that it is error-free, nor does TE make any other representation, warranty or guarantee that the information is accurate, complete, correct, reliable or current. TE reserves the right to make any adjustments to the information contained herein at any time without notice. TE EXPRESSLY DISCLAIMS ALL IMPLIED WARRANTIES REGARDING THE INFORMATION CONTAINED HEREIN, INCLUDING, BUT NOT LIMITED TO, ANY IMPLIED WARRANTIES OF MERCHANTABILITY OR FITNESS FOR A PARTICULAR PURPOSE. In no event will TE be liable for any direct, indirect, incidental, special or consequential damages arising from or related to recipient's use of the information. It is the sole responsibility of recipient of this information to verify the results of this information using their engineering and product environment. Recipient assumes any and all risks associated with the use of the information. Antenna performance may vary. TE is a component manufacturer, and customer and/or end-user is responsible for all end-use compliance and regulatory requirements.

©2025 TE Connectivity. All Rights Reserved.

05/25 Original

TE TECHNICAL SUPPORT CENTER

USA:	+1 (800) 522-6752
Canada:	+1 (905) 475-6222
Mexico:	+52 (0) 55-1106-0800
Latin/S. America:	+54 (0) 11-4733-2200
Germany:	+49 (0) 6251-133-1999
UK:	+44 (0) 800-267666
France:	+33 (0) 1-3420-8686
Netherlands:	+31 (0) 73-6246-999
China:	+86 (0) 400-820-6015