

DESCRIPTION	MATERIAL	FINISH
BODY	BRASS	NICKEL
PIN	BRASS	GOLD
INSULATION	PTFE	N/A

REVISIONS			
REV	DESCRIPTION	DATE	APPV
B	UPDATED FOOTPRINT AND DIMENSIONS; ADDED NEW TITLE BLOCK	29-JUN-12	SAH
C	ADDED DIMPLE TO PART	3-JUN-13	SAH

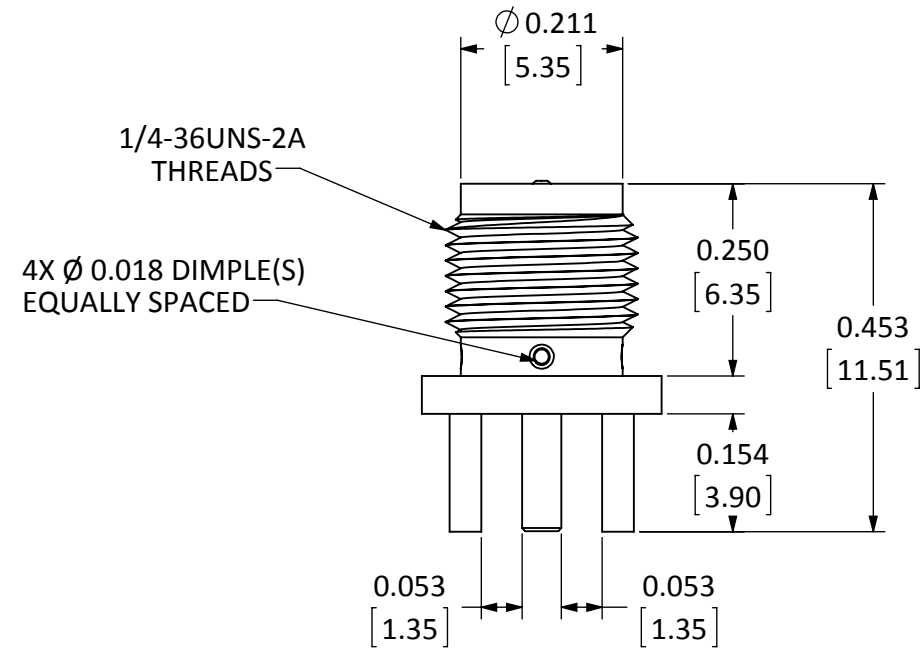

TOP VIEW

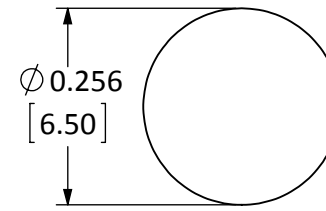

RECOMMENDED MOUNTING HOLE

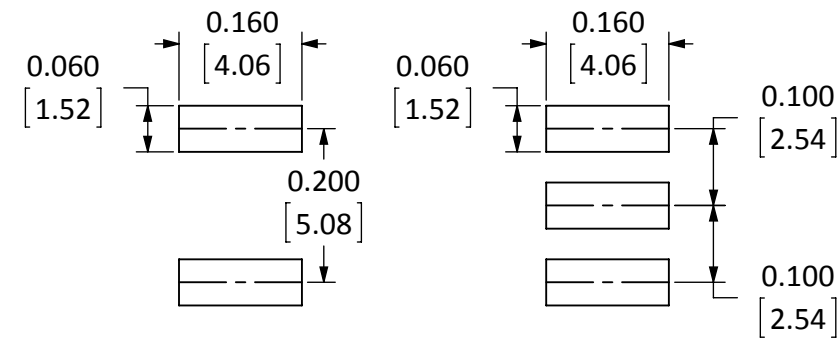

BOTTOM

TOP

RECOMMENDED FOOTPRINT

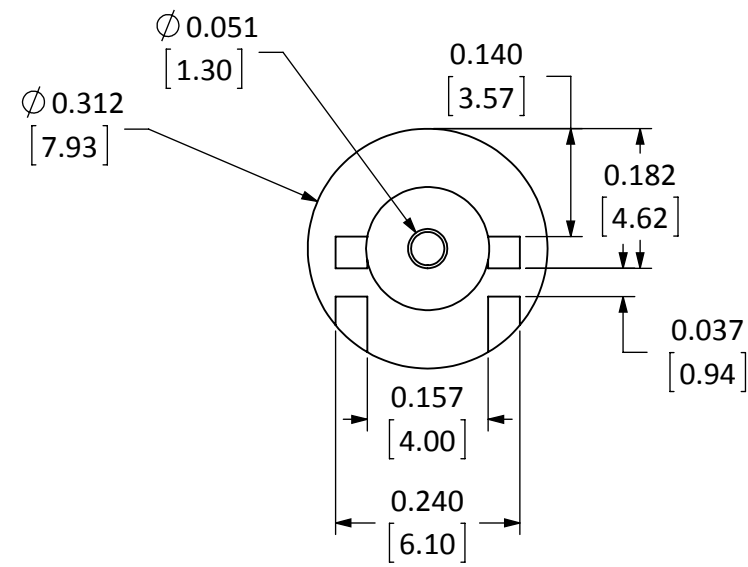

BACK VIEW

NOTES: (UNLESS OTHERWISE SPECIFIED)

1. ALL DIMENSIONS ARE IN INCHES [mm].
2. DIMENSIONS APPLY AFTER FINISHING.
3. MANUFACTURE TO BE COMPLIANT WITH EU RoHS DIRECTIVE.
4. SAFETY BREAK ALL SHARP CORNERS AND EDGES .02 MAXIMUM.

WARNING: THIS DRAWING CONTAINS PROPRIETARY INFORMATION THAT IS THE SOLE PROPERTY OF LINX TECHNOLOGIES, AND SHALL BE TREATED AS SUCH. NO DISCLOSURE OR REPRODUCTION OF THIS DOCUMENT IS PERMITTED, IN WHOLE OR IN PART, WITHOUT THE EXPRESS WRITTEN PERMISSION OF LINX TECHNOLOGIES OR ITS DESIGNATED AGENTS.



TITLE: **RP-SMA FEMALE EDGE MOUNT FOR 0.031" THICK BOARD**

MATERIAL:	INTERPRET DIMENSIONS AND TOLERANCES PER ASME Y14.5.	PROJECTION:
FINISH:	SURFACE FINISH: $\sqrt{}$ ANGLES: $\pm 1^\circ$	
	TOLERANCES: .X \pm .1 .XX \pm .01 .XXX \pm .005	
	DRAWN: B.MURPHY DT: 11-MAR-13	
	ENGR: S.HOGAN DT: 3-JUN-13	

SIZE	DWG. NO.	REV
B	CONREVSMA003.031	C
SCALE: 4:1	DO NOT SCALE DRAWING	SHEET 1 OF 1