

LTR	REVISION	DATE	APPD
G	091318-EE01: UPDATED DIMENSIONS AND NOTES	09-14-18	GP

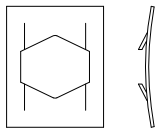

Actual Size

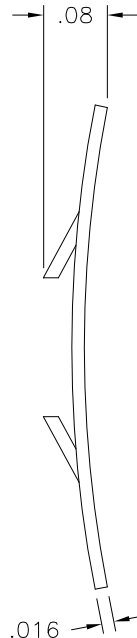
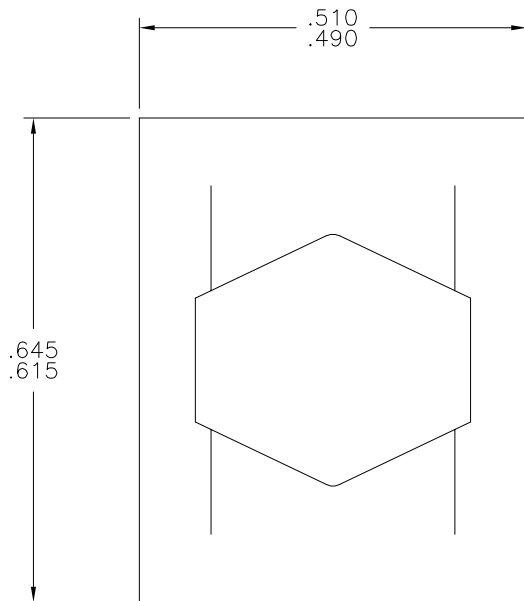
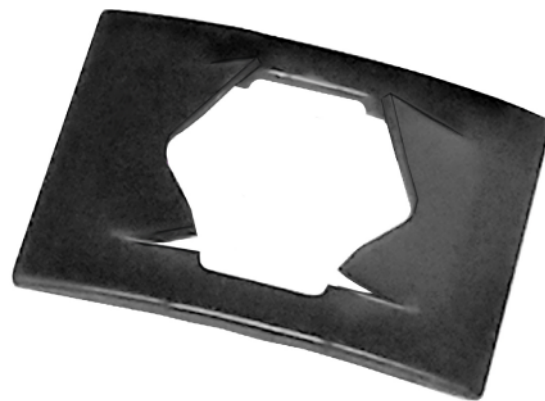

NOTES:

1. MATERIAL: SPRING STEEL
2. FRICTION FIT FOR 0.306"±0.003" SHAFT/STUD

REVISION NOTIFICATION	
<input type="checkbox"/>	DLC
<input type="checkbox"/>	UL/ETL
<input type="checkbox"/>	MADE IN USA
<input type="checkbox"/>	CUSTOMER _____
<input type="checkbox"/>	OTHER
REDLINE CHECKLIST	
<input type="checkbox"/>	REDLINE(YES)
<input type="checkbox"/>	DATE: _____
<input type="checkbox"/>	INITIATED BY: _____
<input type="checkbox"/>	ECR REQUIRED YES <input type="checkbox"/> NO <input type="checkbox"/>
<input type="checkbox"/>	WORK ORDER# _____

LED[®]
LEDTRONICS,™ INC.
 23105 KASHIWA COURT
 TORRANCE, CA 90505

-PROPRIETARY-
 This document contains Proprietary information of LEDTRONICS,™ INC. It may not be copied, used or disclosed for any purpose without the prior express written consent of LEDTRONICS,™ INC.

.XXX ± .010 TOLERANCE PER ANSI-Y14.5
 .XX ± .025 (UNLESS OTHERWISE STATED)
 ANGLES ± 0°,30'
 FRACT. ± 1/32

TITLE					
MTG CLIP SN312					
DWG NO	SCALE	SHEET	DATE		
CMHD0009	4:1	1 OF 1	04-19-95		
CODE IDENT NO.	DWG BY	CHK BY	QA	MFG	R&D
8Z410	SMA 04-19-95		EE 09-14-18	SB 09-14-18	LUV 09-14-18