

ENGINEERING DATA SHEET

SERIES Y

*RELAY - NONLATCH
4 PDT, LOW LEVEL TO 5 AMP*

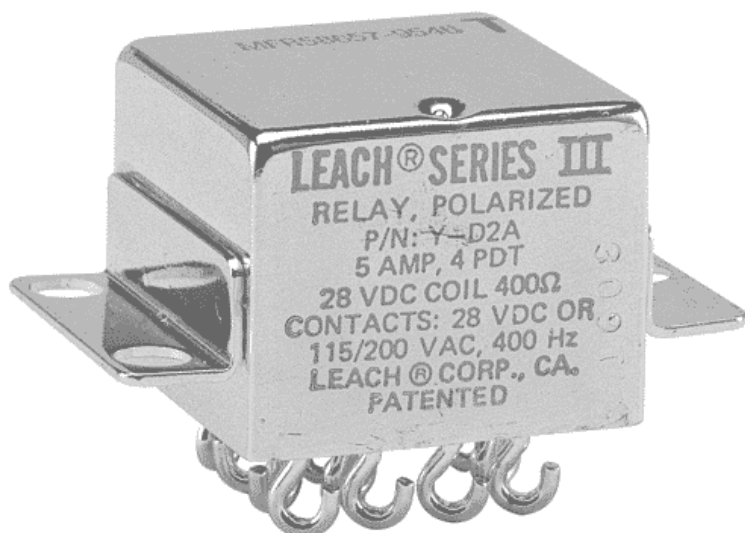

APPLICATION NOTES:

- [101](#)
- [102](#)
- [103A](#)
- [007](#)
- [023](#)

APPLICABLE SOCKETS:

- [SO-1066-001](#)
- [SM-1002-003](#)

All welded construction

Contact arrangement **4 PDT**

Qualified to **MIL-PRF-83536**

PRINCIPLE TECHNICAL CHARACTERISTICS

Contacts rated at **Low level, 28 Vdc and 115/200 Vac 400Hz, 3Ø, case grounded**

Weight **0.058lb max**

Dimensions **.81in x .81in x .64in**

Special models available upon request.

Hermetically sealed, corrosion resistant metal can.

CONTACT ELECTRICAL CHARACTERISTICS

Contact rating per pole and load type [1]	Load current in Amps		
	@28 Vdc	@115 Vac, 400 Hz, 1Ø	@115/200 Vac, 400 Hz, 3Ø
Resistive	5	5	5
Inductive [2]	3	5	5
Motor	2	3	3
Lamp	1	1	-
Overload	20	30	30
Rupture	25	40	40
Low level [3]	-	-	-
Time current characteristics [4]	-	-	-



Featuring **LEACH®** power and control solutions
www.esterline.com

AMERICAS
 6900 Orangethorpe Ave.
 P.O. Box 5032
 Buena Park, CA 90622

Tel: (01) 714-736-7599
 Fax: (01) 714-670-1145

EUROPE
 2 Rue Goethe
 57430 Sarralbe
 France

Tel: (33) 3 87 97 31 01
 Fax: (33) 3 87 97 96 86

ASIA
 Units 602-603 6/F Lakeside 1
 No.8 Science Park West Avenue
 Phase Two, Hong Kong Science Park
 Pak Shek Kok, Tai Po, N.T.
 Hong Kong
 Tel: (852) 2 191 3830
 Fax: (852) 2 389 5803

Data sheets are for initial product selection and comparison. Contact Esterline Power Systems prior to choosing a component.

COIL CHARACTERISTICS (Vdc)**SERIES Y**

CODE	A	B	C	M	N [5]	R [5]	V [5]
Nominal operating voltage	28	12	6	48	28	12	6
Maximum operating voltage	29	14.5	7.3	50	29	14.5	7.3
Maximum pickup voltage							
- Cold coil at +125° C	18	9	4.5	36	18	9	4.5
- During high temp test at +125° C	19.8	9.9	5	38	19.8	9.9	5
- During continuous current test at +125° C	22.5	11.25	5.7	42	22.5	11.25	5.7
Maximum drop-out voltage	7	4.5	2.5	14	7	4.5	2.5
Coil resistance in Ω $\pm 10\%$ at +25° C, except types "C" and "V" +20%, -10%	400	100	25	1275	400	100	25

GENERAL CHARACTERISTICS

Temperature range	-70°C to +125°C
Minimum operating cycles (life) at rated load	100,000
Minimum operating cycles (life) at 25% rated load	400,000
Dielectric strength at sea level	
- All circuits to ground and circuit to circuit	1000 Vrms
- Coil to ground	1000 Vrms
Dielectric strength at altitude 80,000 ft	500 Vrms [6]
Insulation resistance	
- Initial (500 Vdc)	100 M Ω min
- After environmental tests (500 Vdc)	50 M Ω min
Sinusoidal vibration (A and D mounting)	0.12DA / 10 to 70 Hz 30G / 70 to 3000 Hz
Sinusoidal vibration (E mounting in track)	0.06DA / 10 to 57 Hz 10G / 57 to 500 Hz 20G / 500 to 3000 Hz
Sinusoidal vibration (G and J mounting)	0.12DA / 10 to 57 Hz 20G / 57 to 3000 Hz
Random vibration	
- Applicable specification	MIL-STD-202
- Method	214
- Test condition - A and D mounting	1G (0.4G ² /Hz, 50 to 2000 Hz)
- Test condition - E, J and G mounting (E in track)	1E (0.2G ² /Hz, 50 to 2000 Hz)
- Duration	15 minutes each plane
Shock (A, D and J mounting)	200G / 6 ms
Shock (E mounting in track)	50G / 11 ms
Shock (G and J mounting)	100G / 6 ms
Maximum contact opening time under vibration and shock	10 μ s
Operate time at nominal voltage@25°C	6 ms max
Release time at nominal voltage@25°C	6 ms max
Contact make bounce at nominal voltage@25°C	0.5 ms max
Contact release break bounce at nominal voltage@25°C	0.1 ms max [7]
Weight maximum	0.058lb

Unless otherwise noted, the specified temperature range applies to all relay characteristics.

- [1] Standard Intermediate current test applicable; relay can also switch low level load while switching any of the other rated loads on adjacent contacts.
- [2] Inductive load life, 20,000 cycles.
- [3] Low level endurance test: contact load of 10 to 50 millivolt, 10 to 50 microamp, 100 Ohm max. contact resistance.
- [4] Refer to MIL-PRF-83536 for details.
- [5] "N" "R" & "V" coils have back EMF suppression to 42 volts maximum.
- [6] 500 Vrms with silicone gasket compressed, 250 Vrms all other conditions.
- [7] Applicable to Type "N", "R" & "V" coils only.
- 8. Relay will not operate, but will not be damaged by application of reverse polarity to the coil.
- 9. Reference MIL-PRF-83536/5,6,7,8.

NUMBERING SYSTEM

	Y	A	1	A
Basic series designation _____				
1-Mounting Style (A,D,E,G,J) _____				
2-Terminal Types (1,2,4) _____				
3-Coil Voltage see coil characteristics (A,B,C,M,N,R & V) _____				

MOUNTING STYLES

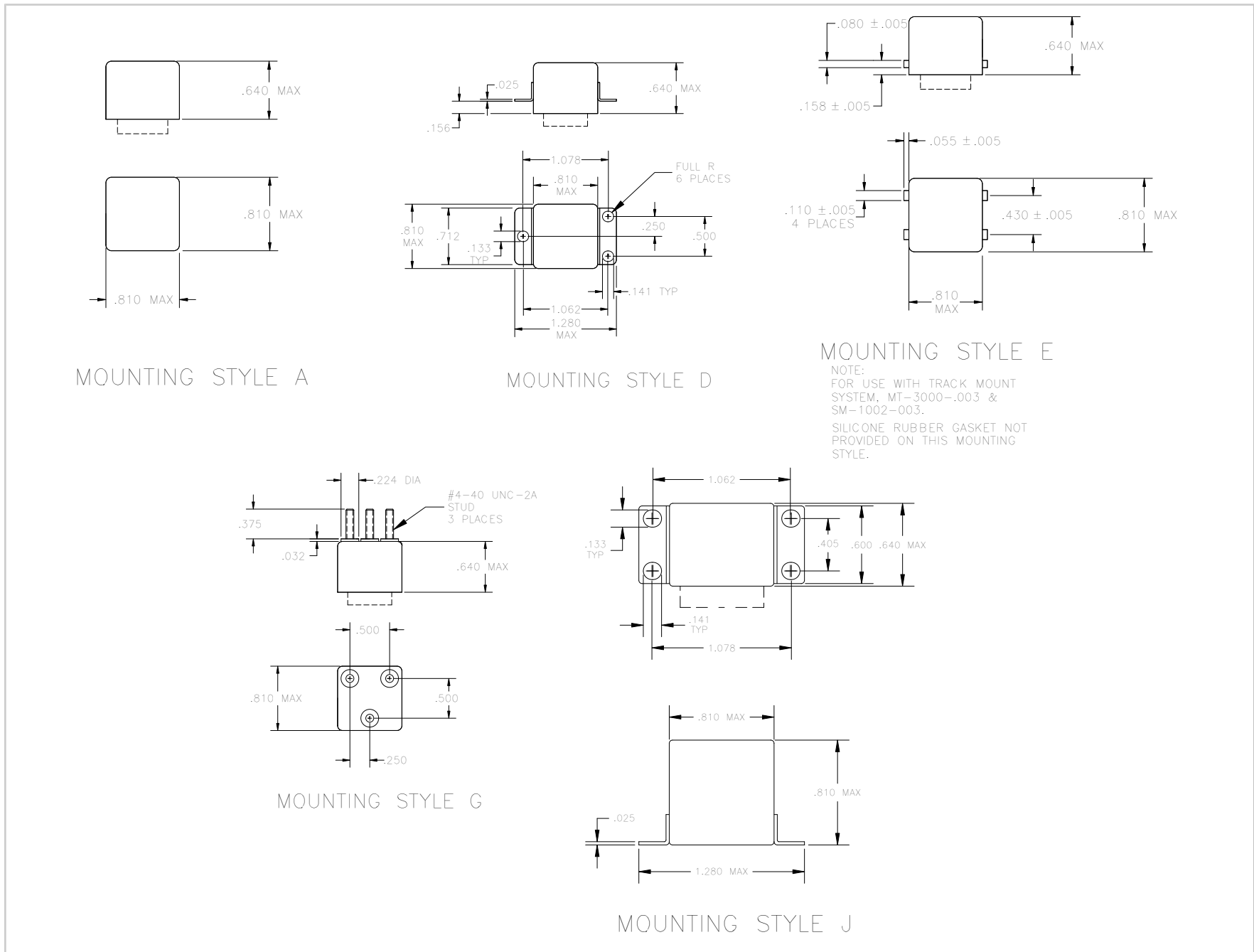

TERMINAL TYPES

SERIES Y

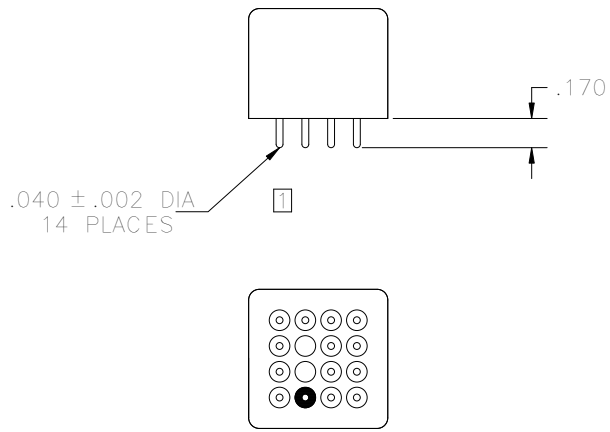

1 INSULATOR P/N RC-RP8000050-1 AVAILABLE FROM ROBISON ELECTRONICS, SAN LUIS OBISPO, CA.

TERMINAL TYPE 1

FINISH:
BODY-TIN/LEAD
TERMINALS-TIN/LEAD

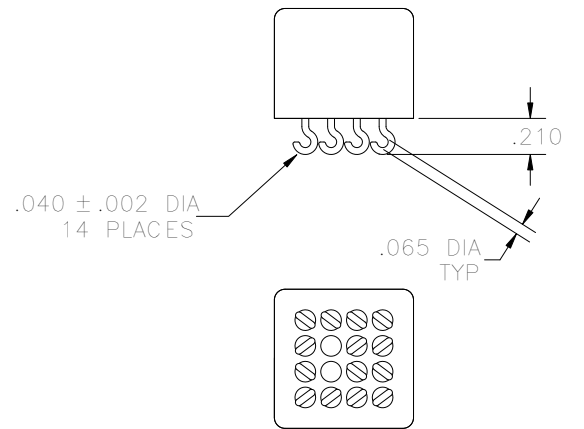

TERMINAL TYPE 2

FINISH:
BODY-TIN/LEAD
TERMINALS-TIN/LEAD

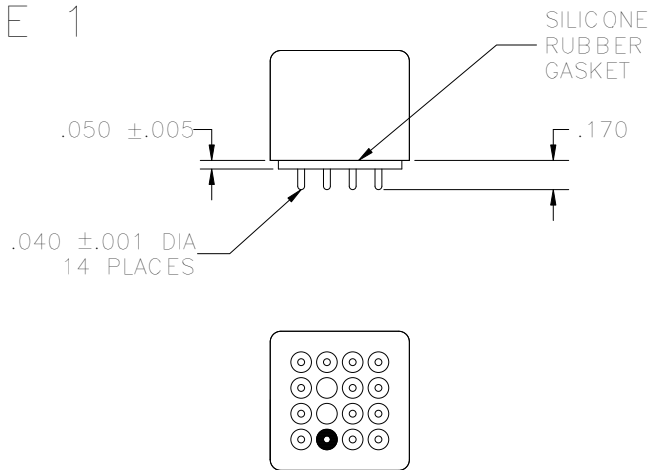

TERMINAL TYPE 4

FINISH:
BODY-TIN/LEAD
TERMINALS-GOLD PLATED

SCHEMATIC DIAGRAM

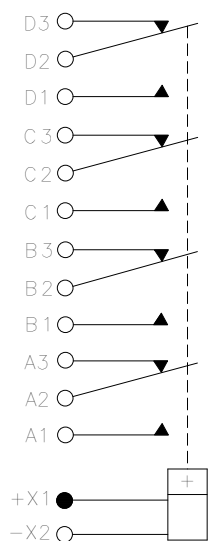

WIRING DIAGRAM

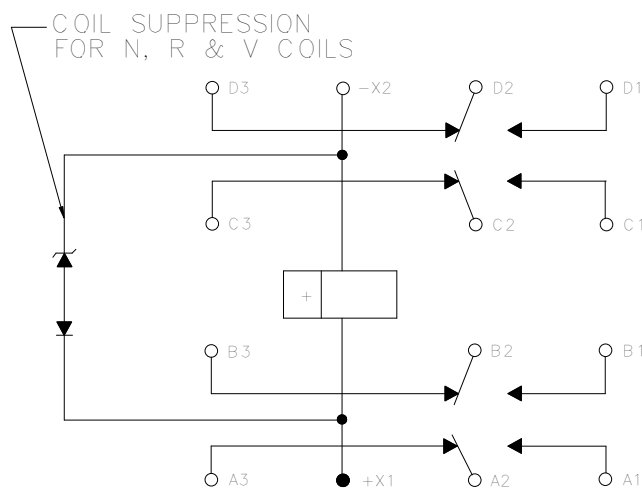

STANDARD TERMINAL LAYOUT

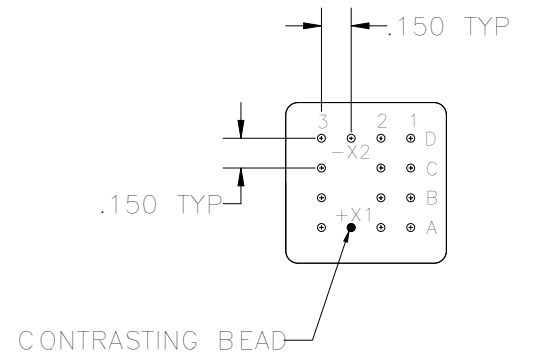

TOL: .XX ±.01; .XXX ±.010