

## 1000W to 1500W Single Output General Purpose Power Supplies

<https://product.tdk.com/en/power/rws-b>  
[www.emea.lambda.tdk.com/rws-b](http://www.emea.lambda.tdk.com/rws-b)



The RWS1000/1500-B are 1000W and 1500W rated AC-DC power supplies, designed to provide solid performance at an economical price. The series accepts a wide range 85 to 265Vac input with output voltages from 12V to 48V. They are certified to IEC62368-1 and EN62477-1 (OVC III). These 7-year warranty products meet both class B radiated and conducted EMI standards. Option model features include an isolated 5V 1A standby voltage, remote on/off and an output-low/fan-fail isolated signal. Up to five units can be connected in parallel for additional power.

Features	Benefits
• Seven Year Warranty	• Low Cost of Ownership
• Conservative Electrolytic Capacitor Ratings	• Long Service Life
• Class B Conducted and Radiated EMI	• Easier System EMC Compliance
• Configurable Output Screw Terminal Block Orientation	• Simplified Cable Connections
• Compact, Enclosed Construction	• Space Saving in End Equipment

Model Selector								
Model	Voltage (V)	Adjustable Range (V)	Max Current (A)	Max Output Power (W)	Load Reg (mV)	Line Reg (mV)	Ripple Noise (mV)	Efficiency (typ at 115/230Vac) (%)
RWS1000B-12	12V	10.2-13.8V	84	1008	96	48	150	82 / 85
RWS1500B-12	12V	10.2-14.4V	125	1500	96	48	150	81 / 85
RWS1000B-15	15V	12.8-17.2V	67	1005	120	60	150	82 / 85
RWS1500B-15	15V	12.8-18.0V	100	1500	120	60	150	82 / 85
RWS1000B-24	24V	20.4-28.8V	42	1008	144	96	180	85 / 88
RWS1500B-24	24V	20.4-28.8V	63	1512	144	96	180	85 / 88
RWS1000B-36	36V	30.6-41.4V	28	1008	216	144	250	85 / 88
RWS1500B-36	36V	30.6-43.2V	42	1512	216	144	250	85 / 88
RWS1000B-48	48V	40.8-57.6V	21	1008	288	192	300	85 / 88
RWS1500B-48	48V	40.8-57.6V	32	1536	288	192	300	85 / 88

<b>RWS1000B-</b>	<b>12</b>	<b>/</b>	<b>S</b>
------------------	-----------	----------	----------

Output voltage 12, 15, 24, 36, 48

blank	Air enters over input/output terminals
/R	Remote On/Off
/FO	PF signal and parallel
/RFO	Remote ON/OFF, Power Fail signal and parallel operation
/RF	Reverse Fan, air exits over input/output terminals
/CO2	Conformal coating
/S	Standby 5V

Specifications		
Model		RWS1000/1500-B
<b>Input</b>		
AC Input Voltage Range (1)	Vac	85 - 265
DC Input Voltage range*	Vdc	120 - 340*
AC Input Frequency	Hz	47 - 63
Input Current (110/230Vac)	A	RWS1000B: 13 / 7, RWS1500B: 19 / 10
Inrush Current at 100/200Vac (Cold Start)	A	60 / 60
Leakage Current	mA	< 1.2
Power Factor (100/200Vac)	-	0.98 / 0.95
Harmonic Compliance	-	Meets IEC61000-3-2
Hold Up Time	ms	20
Efficiency	-	See model selector table
Conducted & Radiated EMI	-	EN55011 / EN55032-B, FCC Class B, VCCI-B
Immunity	-	See immunity table
Safety Agency Certifications	-	IEC/UL/CSA/EN62368-1, 60950-1, CE Mark

Immunity				
Test	Standard	Test Level	Criteria	Notes: See IEC61000 immunity test report on website for further details
ESD	EN61000-4-2	Air ± 8kV and contact ± 4kV	B	
Radiated Susceptibility	EN61000-4-3	80M -1GHz: 10V/m 1.4 - 2.0GHz: 3V/m 2.0 - 2.7GHz: 1V/m	A	
Electrical Fast Transient Burst	EN61000-4-4	± 2kV	B	
Surge	EN61000-4-5	Normal ± 2kV Common ± 4kV	B	
Conducted Susceptibility	EN61000-4-6	10Vrms	A	
Magnetic Fields	EN61000-4-8	30A/m	A	
Voltage Dips	EN61000-4-11	30% 500ms	B	
		60% 10ms	B	
		100% 20ms	A	
		100% 5000ms	B	
Voltage Dips	EN60601-1-2 Ed.4	30% 500ms	B	
		100% 10ms	A	
		100% 20ms	A	
SEMI F47 Line Dip	SEMI F47	100% 5000ms	B	At input voltages > 200Vac

Specifications		
Model		RWS1000/1500-B
<b>Output</b>		
Switching Frequency	kHz	RWS1000B; 95, RWS1500B; 85, PFC converter 65
Line Regulation	-	See model selector table
Load Regulation	-	See model selector table
External Load Capacitance	uF	100,000
Ripple & Noise	-	See model selector table
Temperature Coefficient	%/°C	0.02
Minimum Load	-	No minimum load required
Overcurrent Protection	%	>105. Constant current mode with automatic recovery. A prolonged overload of more than 5s will cause unit to shutdown
Overvoltage Protection	-	Latching (unit shutdown), cycle AC input to reset
Overtemperature Protection	-	Latching (unit shutdown), cycle AC input to reset
Remote Sense	-	Yes
Remote On/Off	-	Optional, See Part Numbering Scheme. ON when the external voltage is applied, OFF when open
DC Good / Fan Alarm	-	See options section
Standby Voltage	-	5V 1A (always on). See Part Numbering Scheme
Indicators	-	Green LED indicates DC is OK
Parallel Operation	-	Optional, See Part Numbering Scheme
Series Operation	-	Possible

Specifications		
Model		RWS1000/1500-B
<b>Environmental</b>		
Operating Temperature	°C	-20 to +60, derate linearly to 60% load from 50 to 60 Reverse air (IRF): -20 to +70, derate linearly to 50% load from 50 to 70
Operating Humidity	%RH	Operating: 20 - 90, Storage: 10 - 90
Storage Temperature	°C	-30 to +75
Humidity (non condensing)	%RH	10 - 90 (Operating & Storage)
Cooling	-	Forced air. Optional reverse fan direction
Altitude	m	3000
Withstand Voltage (For 1 minute)	Vac	Input to ground 2,000, Input to output 4,000, Output to ground 1,500 for 1 minute
Vibration (Non operating)	-	10-55Hz (Sweep for 1min.) 19.6m/s <sup>2</sup> Constant X,Y,Z 1 hour each
Shock (Non operating)	-	Less than 196m/s <sup>2</sup> , 11ms, ±X, ±Y, ±Z 3 times each
<b>Other</b>		
Weight (Typ)	g	RWS1000B: 2000, RWS1500B: 3000
Size (WxHxD)	mm	RWS1000B; 127 x 63 x 198, RWS1500B; 127 x 63 x 261
Size (WxHxD)	Inches	RWS1000B; 5 x 2.48 x 7.8, RWS1500B; 5 x 2.48 x 10.28
Connectors	-	Screw terminal input and output. Signal connectors JST S12B-PHDSS
MTBF - Telcordia SR-332 issue 3**	Hours	1,222,361
Warranty	yrs	7

See website for detailed specifications, test methods and installation manual

(1) Derate linearly to 80% load from 90 to 85Vac input

\*Safety certified for AC input only

\*\*RWS1500B-24 model, 25°C ambient, full load, 24Vdc input

**Outline Drawing RWS1000B**

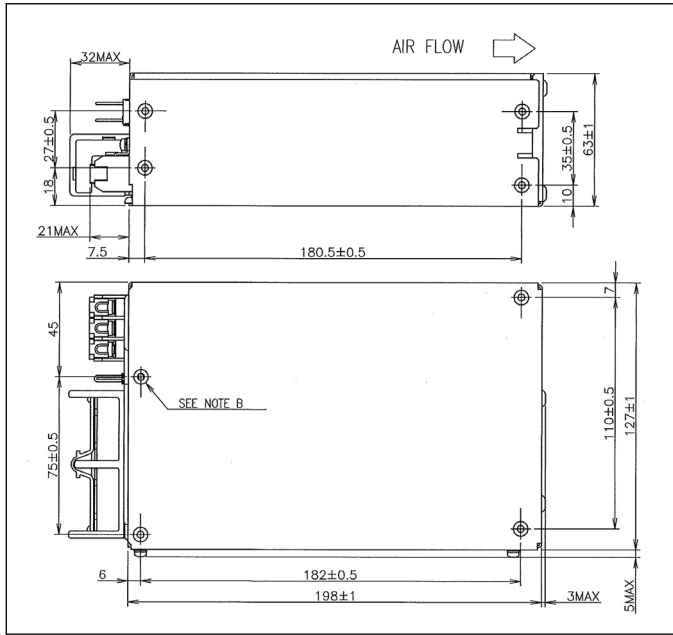

**Outline Drawing RWS1500B**

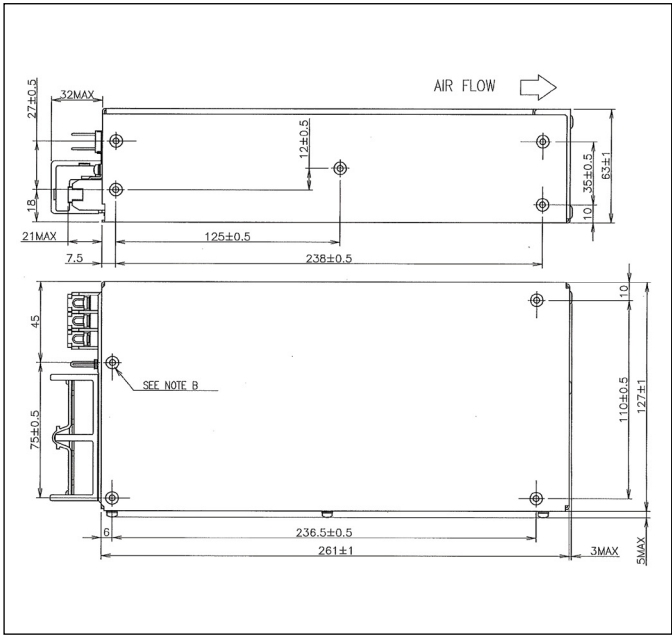



## TDK-Lambda France SAS

Tel: +33 1 60 12 71 65  
france@fr.tdk-lambda.com  
www.emea.lambda.tdk.com/fr



## Italy Sales Office

Tel: +39 02 61 29 38 63  
info.italia@it.tdk-lambda.com  
www.emea.lambda.tdk.com/it



## Netherlands

info@nl.tdk-lambda.com  
www.emea.lambda.tdk.com/nl



## TDK-Lambda Germany GmbH

Tel: +49 7841 666 0  
info@de.tdk-lambda.com  
www.emea.lambda.tdk.com/de



## Austria Sales Office

Tel: +43 2256 655 84  
info@at.tdk-lambda.com  
www.emea.lambda.tdk.com/at



## Switzerland Sales Office

Tel: +41 44 850 53 53  
info@ch.tdk-lambda.com  
www.emea.lambda.tdk.com/ch



## Nordic Sales Office

Tel: +45 8853 8086  
info@dk.tdk-lambda.com  
www.emea.lambda.tdk.com/dk



## TDK-Lambda UK Ltd.

Tel: +44 (0) 12 71 85 66 66  
info@uk.tdk-lambda.com  
www.emea.lambda.tdk.com/uk



## TDK-Lambda Ltd.

Tel: +9 723 902 4333  
info@tdk-lambda.co.il  
www.emea.lambda.tdk.com/il



## C.I.S.

### Commercial Support:

Tel: +7 (495) 665 2627

### Technical Support:

Tel: +7 (812) 658 0463  
info@tdk-lambda.ru  
www.emea.lambda.tdk.com/ru



## TDK-Lambda Americas

Tel: +1 800-LAMBDA-4 or 1-800-526-2324  
powersolutions@us.tdk-lambda.com  
www.us.lambda.tdk.com



## TDK Electronics do Brasil Ltda

Tel: +55 11 3289-9599  
sales.br@tdk-electronics.tdk.com  
www.tdk-electronics.tdk.com/en



## TDK-Lambda Corporation

Tel: +81-3-6778-1113  
www.jp.lambda.tdk.com



## TDK-Lambda (China) Electronics Co. Ltd.

Tel: +86 21 6485-0777  
powersolutions@cn.tdk-lambda.com  
www.lambda.tdk.com.cn



## TDK-Lambda Singapore Pte Ltd.

Tel: +65 6251 7211  
tts.mkt@sg.tdk-lambda.com  
www.sg.lambda.tdk.com



## TDK India Private Limited, Power Supply Division

Tel: +91 80 4039-0660  
mathew.philip@in.tdk-lambda.com  
www.sg.lambda.tdk.com

