



ENGINEERING CATALOG

July, 2009



**POWER
BLOCKS**



**FUSE
HOLDERS**

What's New:
UL Listed Enclosed
Power Distribution Blocks

CE 1000 Volt Ratings

**Datasheets on
www.marathonsp.com**



**ENCLOSED
POWER
BLOCKS**



**CUSTOM
PRODUCTS**



**TERMINAL
BLOCKS**

Marathon is...

Quality • Shortest Delivery Times • Customer Satisfaction



Table of Contents

1000 Volt CE Ratings	2	Double Row Terminal Blocks (cont.)	
General Information	3 - 4	603 GP Series	83
Flexible Stranded Wire	5 - 6	604 GP Series	84
Fuse Holders		605 GP Series	85
General Information	7 - 8	621 RZ Series	86
Class H & K Fuse Panels - 250 Volt	9 - 10	670A RZ Series	87
Class H & K Fuse Holders - 250/600 Volt	11	671 RZ Series	88
Class R Fuse Holders - 250/600 Volt	12	672 RZ Series	89
Class H, K & R Fuse Holder Dimensions	13 - 15	Single Row Terminal Blocks	
Class T Fuse Holders - 300/600 Volt	16	General Information	90
Class T Fuse Holder Dimensions	17 - 18	411 Series	91
Class J Fuse Holders - 600 Volt	19	599 Series (799 Riveted)	92
Class J Fuse Holder Dimensions	20 - 21	699 Series (899 Riveted)	93
M Fuse Holders - 600 Volt	22	812 Series (912 Riveted)	94
Midget Enclosed Fuse Holders - 600 Volt	23	1690 Series	95 - 96
Midget Fuse Holders (Sectional) - 600 Volt	24	2590 Series	97
CC Fuse Holders - 600 Volt	25	2690 Series	98 - 99
CC Enclosed Fuse Holders - 600 Volt	26	Terminal Block Accessories	
Class G Fuse Holders	27	Kliptite/Quick Connect (Single Row)	100
Semi Conductor Fuse Holder (Box) - 1,000 Volt	28	Kliptite/Quick Connect (Double Row)	101
Semi Conductor Fuse Holder (Stud) - 1,000 Volt	29	Solder Terminal Lugs (ST, 3/4 ST, Y, YSY, Z)	102
Fuse Holders with Box Distribution Connectors	30	JJS/RJ/RJS Jumpers, Wire Clamp, Straddle Plate	103
STSF Forklift/Semi Conductor Fuse Holder	31	Fanning Strips	104
Fuse Holder Covers	32 - 33	Stud & Turret Terminal Blocks	105
DIN Rail Adapters	34	Top Mounted Covers/Marking Strips (Double Row)	106
Short Circuit Current Ratings	35	Sub Mounted Marking Strips (Double Row)	107
UL Listed Power Distribution Blocks	36 - 37	Marking and Insulator Strips	108
UL Listed Enclosed Power Blocks	38	Marking Strip Dimensions (Single Row)	109
Enclosed Power Blocks	39 - 40	Marking Strip Dimensions (Double Row)	110
Power Terminal Blocks		Terminal Block Printing	111
General Information	41	Sectional Terminal Blocks	
Power Distribution Blocks	42 - 45	General Information	112
Power Splicer Blocks	46 - 47	3/8" Sectional Blocks	113 - 116
Power Stud Blocks	48	1/2" Sectional Blocks	117
Miscellaneous Power Splicer Blocks	49	11/16" Sectional Fuse Holder	118
Power Splicer/Stud Blocks	50	DIN Rail Terminal Blocks	
Power Stud to Distribution Blocks	51	General Information	119
Power Terminal Block Dimensions	52 - 54	MIK3	120
Power Block Covers	55	MIK5	121
Grounding Lugs - GL	56	MIK10	122
Studded Power Feed Thru TB's		MIK16	123
General Information - ST722 Series/Covers	57	MIK25	124
ST722B Series (back mount)	58	DIN Rail Disconnect - MIKTS4	125
ST722S Series (slide-in mount)	59	Fuse Terminal Block - MIKSI5	126
ST722E Series (end mount)	60	MIKE4	126
ST715S1902 and cover	61	MIKE10	126
ST723B38 Series (back mount)	62	MIKE16	126
Single Stud Connection Block	63	DIN Accessories	127
Heavy Duty Terminal Blocks		Military and Navy Class TB's	
General Information	64	General Information - Military Class	128
1100 Series	65	37TB-B & 40TB-B Series	129
1103P & 1200 Series	66	37TB F & 38TB F Series	130
0987 RZ Series	67	39TB F & 40 TB F Series	131
985 GP Series	68	41TB F & 42TB F Series	132
1500 Series	69	LD, LS Options	133
1600 Series	70	Military Block Marking Styles	134
1700 Series	71	General Information - Navy Class	135
Double Row Terminal Blocks		3TB, 4TB, 5TB, 6TB Series	136
General Information	72	7TB, 8TB, 9TB, 10TB, 11TB Series	137
100/670A GP Series	73	15TB, 16TB, 17TB, 25TB, 26TB Series	138
200/671 GP Series	74	Index	139 - 140
200HB Series	75	Terms and Conditions	141 - 142
300/672 GP Series	76	Warnings and Cautions	143
400 Series	77	Custom Products	144
410 GP Series	78		
600 GP Series	79		
600A GP Series (800A Riveted)	80		
601 GP Series (801 Riveted)	81		
602 GP Series (802 Riveted)	82		

1,000 Volt CE Ratings

Voltage Ratings per IEC 60947-1 and IEC 60947-7-1

Enclosed Power Blocks				NEMA Power Blocks			
Catalog Description	Voltage Rating (Ui) - AC/DC	Current Range AMP	Special Features/Notes	Catalog Description	Voltage Rating (Ui) - AC/DC	Current Range AMP	Special Features/Notes
LISTED ENCLOSED POWER BLOCKS				132XXXX	1,000	up to 175	
EPBAD21	1,000	up to 115	Din/Panel Mount	133XXXX	1,000	up to 510	
EPBAD24	1,000	up to 115	Din/Panel Mount	140XXXX	1,000	up to 310	
RECOGNIZED ENCLOSED POWER BLOCKS				141XXXX	800	up to 115	
EPBXD41	800	up to 175	Din Rail Mount	142XXXX	1,000	up to 175	
EPBXP41	1,000	up to 175	Panel Mount	143XXXX	1,000	up to 350	
EPBXD44	800	up to 175	Din Rail Mount	144XXXX	1,000	up to 420	
EPBXP44	1,000	up to 175	Panel Mount	145XXXX	1,000	up to 760	
EPBXD74	800	up to 335	Din Rail Mount	Heavy Duty Terminal Blocks			
EPBXP74	1,000	up to 335	Panel Mount	Catalog Description	Voltage Rating (Ui) - AC/DC	Current Range AMP	Special Features/Notes
EPBXP74	1,000	up to 335	Din Rail Mount	1100 Series	630	up to 65	
EPBXD71	800	up to 510	Din Rail Mount	1200 Series	800	up to 70	
EPBXP71	1,000	up to 510	Panel Mount	0987 Series	1,000	up to 50	
				985 Series	630	up to 85	
				1500 Series	1,000	up to 75	>30A ring lug
				1600 Series	1,000	up to 75	>30A ring lug
				1700 Series	1,000	up to 75	>30A ring lug

Voltage Ratings per IEC 60269-1 and IEC 60269-2

Fuse Holders				Fuse Holders			
Catalog Description	Voltage Rating (Ui) - AC/DC	Current Range AMP	Special Features/Notes	Catalog Description	Voltage Rating (Ui) - AC/DC	Current Range AMP	Special Features/Notes
ENCLOSED CLASS M FUSE HOLDERS				NEMA CLASS T FUSE HOLDERS			
6SM30AXB	1,000	up to 30	Marathon certifies 1000 Volt Rating	T30AXB	800	up to 30	Final voltage ratings of these fuse holders depends upon availability and voltage ratings of applicable fuses.
6SM30AXIB	1,000	up to 30		6T30AXXX	800	up to 30	
SEMI-CONDUCTOR FUSE HOLDERS				T60AXX	800	31 ~ 60	
ST14	1,000	up to 100	R6T60AXB	800	31 ~ 60		
ST38	1,000	up to 600	T100A1B	1,000	61 ~ 100		
1MS101	1,000	up to 100	T100A3B	800	61 ~ 100		
1MS102	1,000	101 ~ 400	T200A1B	1,000	101 ~ 200		
1MS103	1,000	101 ~ 400	T200A3B	800	101 ~ 200		
1MS104	1,000	401 ~ 600	T400A1B	1,000	201 ~ 400		
NEMA CLASS M FUSE HOLDERS				T600A1B	1,000	401 ~ 600	
6M30AXX	800	up to 30	Fuse holders meet spacing and insulator material requirements for the listed voltage. Final voltage ratings depend upon ratings of available fuses.	6T100A1B	1,000	61 ~ 100	
NEMA CLASS J FUSE HOLDERS				6T100A3B	800	61 ~ 100	
6J30AXX	1,000	up to 30		6T200A1B	1,000	101 ~ 200	
6J60AXB	800	31 ~ 60		6T200A3B	800	101 ~ 200	
R6J100AXB	1,000	61 ~ 100		6T400A1B	1,000	201 ~ 400	
6J200AXBFB	1,000	101 ~ 200		6T600A1B	1,000	401 ~ 600	
6J400A1BFBD	1,000	201 ~ 400					
6J400A3BFBD	800	201 ~ 400					
6J600AXBFB	1,000	401 ~ 600					

Notes (applies to two groups)

1. Rated Impulse Withstand Voltage (Uimp) - 6,000V
2. Material Group - IIIa except 6M30AX series in Fuse Holders with material group - I
3. Pollution Group - 3



General Information

Marathon Special Products, a Regal Beloit Company, has served the electrical/electronic component industry for over 70 years. Our facility in Bowling Green, Ohio contains all manufacturing and warehousing operations including an extensive electrical test lab.

We offer a broad range of fuse holders and terminal blocks, including Kulka® terminal blocks. In addition, we have the expertise to design and manufacture non-standard products for specific customer applications.

On February 1, 1994, Marathon Special Products was registered to ISO standards. We are currently registered to ISO 9001:2000 quality standards.

Marathon Special Products also offers a line of DIN sectional terminal blocks.

Agency Approvals:

The majority of products manufactured by Marathon Special Products are Underwriters Laboratories and Canadian Standards Association approved.

The approval status of products can be found throughout the catalog. Below are the different approval forms and brief descriptions.



Listed by Underwriters Laboratories, products are qualified for use in equipment without end-use agency approval when applied within products rated performance.



Recognized by Underwriters Laboratories, suitable for use only in end-use equipment where Underwriters Laboratories determine acceptability of the combination.



Certified by Canadian Standards Association, suitable for use in other equipment where Canadian Standards Association determines the suitability of the combination.



Compliance with European Union Low Voltage Directive.

Environmental Compliance:

All products offered by Marathon Special Products are RoHS compliant and do not require REACH notification.

Tightening Torque:

Recommended tightening torque is listed for all products, either on the carton label or the product label. All torque recommendations are based on UL 486. In some cases, because of various connector designs, our recommended torque is different from the torque tables shown in UL 486. However, these products passed the heating cycling and static heating tests as specified in UL 486.

Wire Ampacity:













The ampacity of a wire is its current carrying capacity with reference to the cross sectional area of the conductor(s), the temperature rating of the insulation and ambient temperature.







Marathon specified wire ranges are based on UL approved tests using 75°C wire. Wires with temperature ratings other than 75°C are approved while observing NEC Article 310 wire tables for allowable ampacities of insulated conductors. Marathon voltage and amperage ratings remain constant and are independent of the temperature rating of the wire used in application. Wire gauges and type must remain within the Marathon specified ranges to be UL approved. However, UL approval for higher currents may be obtained in some end-use applications.

General Information

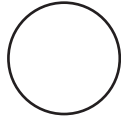
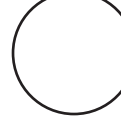
Wire Chart:

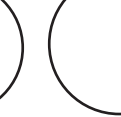
Stranded wire sizes and ampacity based on NEC Table 310-16, 75°C column.

													
SIZE	#14	#12	#10	#8	#6	#4	#3	#2	#1	1/0	2/0	3/0	4/0
DIAMETER	.073	.092	.115	.146	.184	.235	.281	.295	.335	.380	.420	.475	.530
AMPS	15	20	30	50	65	85	100	115	130	150	175	200	230

							
SIZE	250kcmil	300kcmil	350kcmil	400kcmil	500kcmil	600kcmil	750kcmil
DIAMETER	.580	.635	.690	.730	.820	.893	.998
AMPS	255	285	310	335	380	420	475

Tolerances for Catalog Dimensions:

Length Dimensions	Tolerance	All Other Dimensions	Tolerance
1.0"-5.0"	± .030	X.X"	± .030
5.1"-10.0"	± .050	X.XX"	± .020
10.1"-15.0"	± .060	X.XXX"	± .010

Note: Catalog Dimensions are for Guidance only and are not to be construed as inspection standards.

This catalog is intended to present product data that will help the end user with design application. Since changes to products occur, it is recommended that the end user request samples for evaluation. Marathon Special Products reserves the right to change or update without notice. Please visit www.marathonsp.com for the most up-to-date product information.

Torque Conversions:

Lb-in	N-m	Lb-in	N-m	Lb-in	N-m
2	0.2	25	2.8	100	11.3
5	0.6	30	3.4	120	13.6
6	0.7	35	4.0	150	16.9
8	0.9	40	4.5	192	21.7
10	1.1	45	5.1	275	31.1
15	1.7	50	5.6	375	42.4
18	2.0	61	6.9	422	47.7
20	2.3	80	9.0	500	56.5

Wire Connectors Investigated for Flexible Stranded Wire

Specifications:

- Screw-type mechanical pressure wire connectors investigated to UL 486A-B for flexible stranded wire
- UL 508A (Industrial Control Panels), Section 29.3.11

Affected Standards:

- UL 486A-486B (Wire Connectors Standard)
- UL 508A (Industrial Control Panels Standard)
- UL 1059 (Terminal Block Standard)
- NEC (National Electric Code) 110.3 (A)7 and (B)
- NEC 690 (in 2008)

Until now, to be UL and NEC compliant while using flexible stranded wire, it was necessary to use crimp-type ring lugs investigated for flexible stranded wire. By using Marathon's UL 486A-B investigated screw-type pressure connectors in place of crimp lugs, you can save up to 66% of termination costs in material and labor.

Marathon's wire approvals, in addition to Classes B and C, now include stranding Classes G, H, I and K. The photo shows two distinctly different stranding classes, both 250 kcmil. The wire on the left, Class B, has 61 strands. The wire on the right, Class K, has approximately 2499 strands. A table providing information on wire sizes, Classes and strand count can be found on the next page.

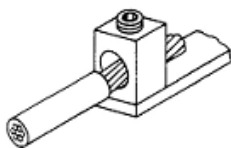
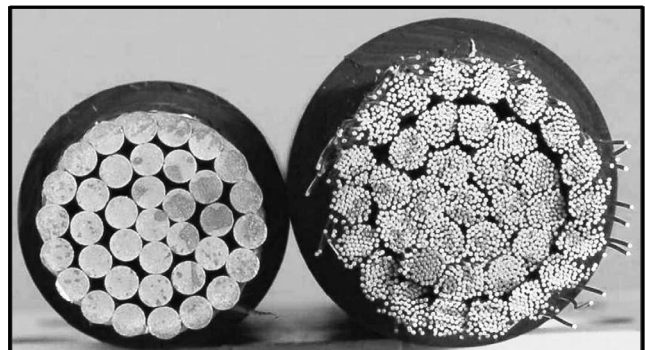

29.3.11 Flexible conductors, including welding cable and machine tool wire identified as "Flexing" or "Class K", shall be retained by terminals that have been evaluated to the Standard for Wire Connectors, UL 486A-486B for the size and type of conductors involved.

Added 29.3.11 effective March 1, 2007

For specific rating information view our online datasheets at www.marathonsp.com

Copper Stranded Wire Classes

Wire Gauge	AWG/kcmil							Wire Gauge
	Rigid Stranded			Flexible Stranded				
	CSA Compact	Class B	Class C	Class G	Class H	Class I	Class K	
Number of Strands	Number of Strands	Number of Strands	Number of Strands*	Number of Strands*	Number of Strands*	Number of Strands*	Number of Strands*	
#20 AWG		7	19				10	#20 AWG
#18		7	19				16	#18
#16		7	19				26	#16
#14		7	19			19	41	#14
#12		7	19			19	65	#12
#10		7	19			27	104	#10
#8	7	7	19	49	133	41	168	#8
#6	7	7	19	49	133	63	266	#6
#4	7	7	19	49	133	105	420	#4
#2	7	7	19	49	133	161	665	#2
#1	19	19	37	133	259	210	836	#1
1/0	19	19	37	133	259	266	1064	1/0
2/0	19	19	37	133	259	342	1323	2/0
3/0	19	19	37	133	259	418	1666	3/0
4/0	19	19	37	133	259	532	2107	4/0
250 kcmil	37	37	61	259	427	637	2499	250 kcmil
300 kcmil	37	37	61	259	427	735	2989	300 kcmil
350 kcmil	37	37	61	259	427	882	3458	350 kcmil
400 kcmil	37	37	61	259	427	980	3990	400 kcmil
500 kcmil	37	37	61	259	427	1225	5054	500 kcmil
600 kcmil	37	37	61	427	427	1470	6065	600 kcmil
750 kcmil	37	61	61	427	427	1850	7581	750 kcmil
1,000 kcmil	37	61	61	427	427	2527	10101	1,000 kcmil

Wire Gauge	mm ²		Wire Gauge
	Rigid	Flexible	
	Class 2	Class 5	
Number of Strands	Number of Strands*		
.50 mm ²	7	16	.50 mm ²
0.75	7	24	0.75
1.50	7	30	1.50
2.50	7	50	2.50
4	7	56	4
6	7	84	6
10	7	80	10
16	7	128	16
25	7	200	25
35	7	280	35
50	19	400	50
70	19	356	70
95	19	485	95
120	37	614	120
150	37	765	150
185	37	765	185
240	61	1225	240
300	61	1530	300

*Specific quantity of strands for Classes G, H, I, K and 5 vary by manufacturer.

For additional information on copper stranded wire classes and approvals on Marathon products go to www.marathonsp.com

General Information:

Marathon has been manufacturing quality fuse holders for over 40 years. The key word is quality. It is incorporated into every Marathon fuse holder, right along with design.

The product line includes a broad range of holders to accommodate the following fuses: Class H, K, R, T, J, CC, G, CD, M (Miscellaneous) and Semi-Conductor holders.

The majority of these fuse holders are available from 250 to 1000 volts at current ratings from 30 through 600 Amperes. Our Class M fuse holders and Semi Conductor fuse holders (Box and Stud versions) have a CE rating of 1000 Volts.

The Class R, T, J, CD, CC and Semi-Conductor fuse holders have passed 200,000 ampere high current interrupt testing in accordance with the fuse holder standard UL 512 (and will comply to new harmonized standard UL 4248 when effective).

Class R and CC fuse holders have a rejection feature, which prevents the insertion of a fuse with lower interrupting rating. Class T and J fuse holders prevent the use of fuses with lower interrupting rating because of their unique size.

Fuse Clips:

Marathon's 30 and 60 Amp fuse holders are equipped with the patented "Cool-Clip®" design. The heat generated in a fuse clip can actually reduce the life of the fuse, the clip and the conductor, as well as the protection power of the fusing device. No longer is it necessary for heat build-up to rob equipment of protection and extended life.

Reinforcing members are available for most Marathon fuse holders and are recommended for use where an improved performance is desired or more severe conditions exist. They are recommended for electric heat or where high ambient temperatures are present.

To comply with Automotive Industry Standard ET-2 use the following options:

- Class H Fuse Holder with Reinforcing Member
- 30 Amp use SP Connectors or Copper Box Connectors
- 60 Amp use Copper Box Connectors

Marathon Special Products fuse holders will comply to new harmonized fuse holder standard 4248. Please refer to www.marathonsp.com for the latest updates.

Wire Connectors:

Marathon fuse holders are available with five types of wire connectors.

S Screw Connector

An economical connector for use with a wire, or either a ring or spade type terminal. Screw is #10-32 steel.

SQ Screw Connector w/Quick Connects

Same as screw connector with additional quick connect options.

SP Sems Pressure Connector

A positive pressure connector eliminating the need for a wire terminal. Ideal for use where there is a vibration problem. Sems pressure screw is #10-32 steel.

SPQ Sems Pressure Connector w/Quick Connects

Same as Sems connector with additional quick connect options.

B Box Connector

Suitable for use with stranded or solid wire. Connector is aluminum tin plated.

Copper Box Connectors are available on 30 and 60 amp fuse holders. Add CU after the catalog number.

Wire Ranges:

All wire ranges shown in the fuse holder section are the ranges of the wire that the connector will accept or that is recommended for the fuse holder assembly.

Ordering Code:

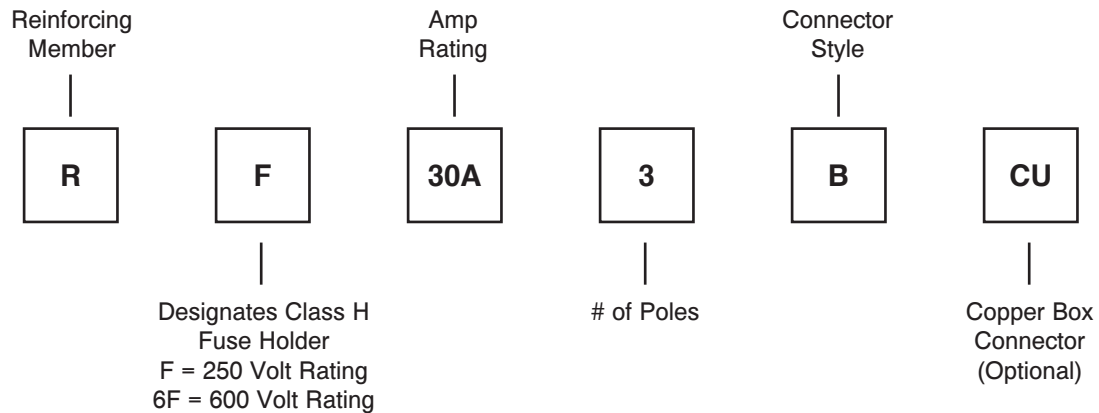

Applications:

Marathon fuse holders can be used in various applications, including control panels, lighting and heating circuits, motor circuits, circuit breaker protection, switchgear equipment, appliances, electric heat, air conditioning and refrigeration equipment, elevator systems and transformer protection.

Marathon Special Products fuse holders will comply to new harmonized fuse holder standard 4248. Please refer to www.marathonsp.com for the latest updates.

Class H & K Fuse Panels

30 and 60 Amp - 250 Volt

Specifications:

- Base, General Purpose Phenolic, 150°C
- Patented Cool-Clip® Design
- Clip, Copper Alloy, Tin Plated
- Reinforcing Member Available
- Bus Bars are Available with 2/0 - #14 AWG or 250 kcmil - #6 Wire Ranges
- Consult Customer Service for Special Requirements
- UL Recognized File No. IZLT2.E35113
- CSA Certified File No. LR21455
- **CE**
- RoHS Compliant



Ordering Code:

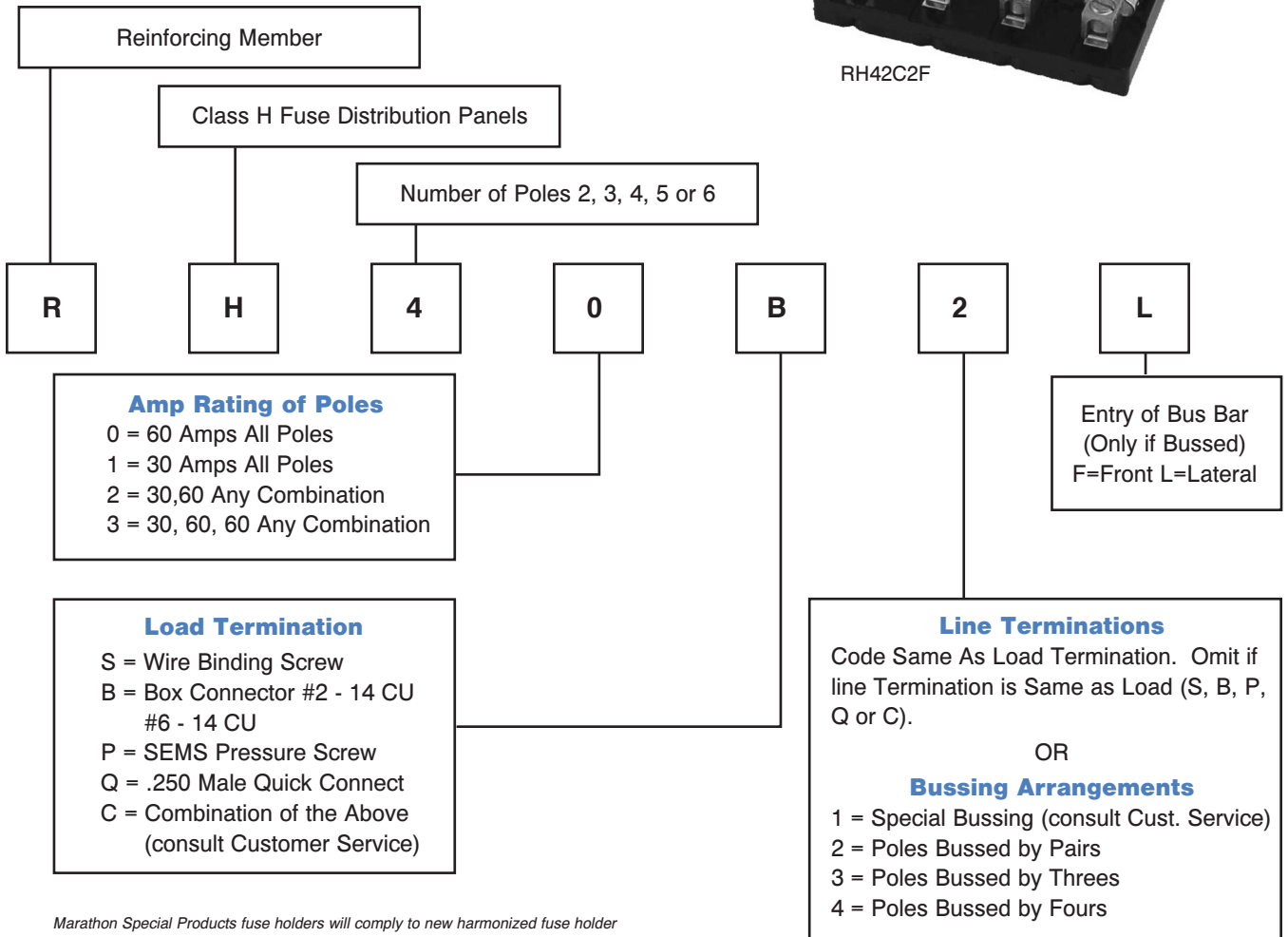

Marathon Special Products fuse holders will comply to new harmonized fuse holder standard 4248. Please refer to www.marathonsp.com for the latest updates.

Class H & K Fuse Panels (cont.)

30 and 60 Amp - 250 Volt

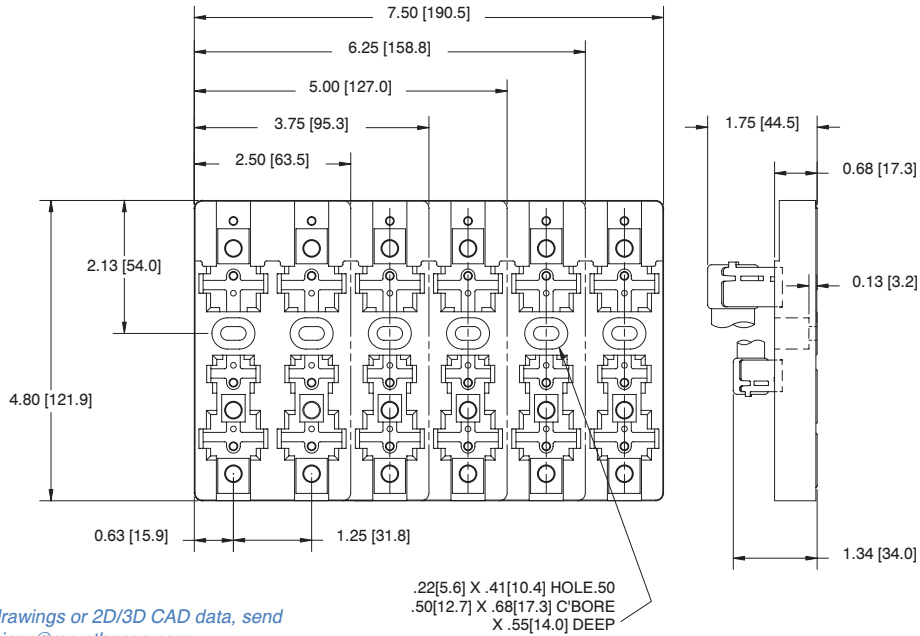

For electronic drawings or 2D/3D CAD data, send request to drawings@marathonsp.com

Poles No.	Dimensions (in) L	(mm)	Poles No.	Dimensions (in) L	(mm)	Dimensions (in) (mm)
2	2.50	63.5	5	6.25	158.8	(in) (mm)
3	3.75	95.25	6	7.50	190.5	(mm)
4	5.00	127.0				

Fuse Distribution Panel Options

Circle/indicate one item per pole and number of poles. The items to be indicated are within the rectangles.

Bussing is only available on line side. If bussing, indicate lug size 2/0 or 250 kcmil (F = Front entry, L = Lateral entry)

Consult Customer Service for other modifications.

Marathon Special Products fuse holders will comply to new harmonized fuse holder standard 4248. Please refer to www.marathonsp.com for the latest updates.

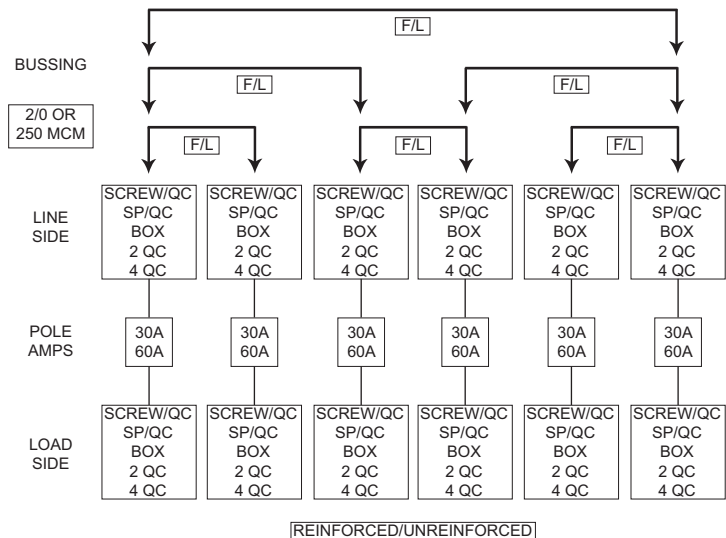

Class H & K Fuse Holders - 250/600 Volt

Specifications:

- Approved for 10,000 Amp Withstand Rating and Short Circuit Current Ratings (SCCR)
- UL Listed File No. IZLT.E35113
- CSA Certified File No. LR21455
- CE
- RoHS Compliant

30 & 60 Amp

- Clip, Copper Alloy, Tin Plated
- Patented Cool-Clip® Design

200 Amp

- Clip, One Piece Aluminum, Tin Plated

100 Amp

- Clip, Copper Alloy, Tin Plated

400 & 600 Amp

- Clip, Copper Alloy, Tin Plated

250 Volts - Catalog #:

Replace "X" with # of poles

Standard	Reinforced	Poles (X)	Amps	Base Materials	Wire Range	Fuse Size	Fuses
F30AXS	RF30AXS	1/2/3	30	Thermoplastic	#10-#22 AWG CU	9/16" DIA BY 2"	A2Y
F30AXSP	RF30AXSP				#10-#14 AWG CU		CRN
F30AXB	RF30AXB				#6-#14 AWG CU	NLN	
F60AXSQ*	RF60AXSQ*				#10-#22 AWG CU	NON	
F60AXB	RF60AXB		60		#2-#14 AWG CU #2-#12 AWG AL	13/16" DIA BY 3"	NRN
RF100AXB	SAME	1/3	100	Phenolic	2/0-#14 AWG CU 2/0-#12 AWG AL	1" DIA BY 5 7/8"	OT
F200AXBE			200	Polyester	250 kcmil - #6 AWG CU AL	1 1/2" DIA BY 7 1/8"	OTN
RF400AXB			400	Phenolic	(2) 350 kcmil - 1/0 AWG CU AL	2 13/32" DIA BY 8 5/8"	RLN
F600AXB	N/A		600		(2) 500 kcmil - 1/0 AWG CU AL	2 29/32" DIA BY 10 3/8"	RF

*UL Recognized File No. IZLT2.E35113

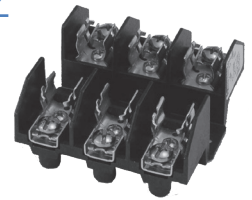

F30A3SP

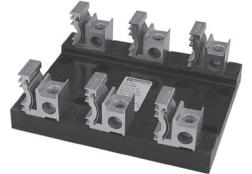

F200A3BE

600 Volts - Catalog #:

Replace "X" with # of poles

Standard	Reinforced	Poles (X)	Amps	Base Materials	Wire Range	Fuse Size	Fuses
6F30AXS	R6F30AXS	1/2/3	30	Phenolic	#10-#22 AWG CU	13/16" DIA BY 5"	A6Y
6F30AXSP	R6F30AXSP				#10-#14 AWG CU		CRS
6F30AXB	R6F30AXB				#6-#14 AWG CU	NLS	
6F60AXB	R6F60AXB				#2-#14 AWG CU #2-#12 AWG AL	NOS	
R6F100AXB	SAME	1/3	100		2/0-#14 AWG CU 2/0-#12 AWG AL	1 11/32" DIA BY 7 7/8"	NRS
6F200AXBE			200	Polyester	250 kcmil - #6 AWG CU AL	1 3/4" DIA BY 9 5/8"	OTS
R6F400AXB			400	Phenolic	(2) 350 kcmil - 1/0 AWG CU AL	2 29/32" DIA BY 11 5/8"	RES
6F600AXB	N/A		600		(2) 500 kcmil - 1/0 AWG CU AL	3 7/16" DIA BY 13 3/8"	RFS RLS



6F30A3B

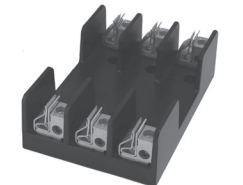

R6F100A3B

Contact Customer Service for Stud Options
See pages 13-15 for dimensional information

See pages 32-33 for available covers
See page 34 for DIN Rail Adapter

Marathon Special Products fuse holders will comply to new harmonized fuse holder standard 4248. Please refer to www.marathonsp.com for the latest updates.

Class R Fuse Holders - 250/600 Volt

Specifications:

- Tested and Approved for 200,000 Amp Withstand Rating and Short Circuit Current Ratings (SCCR)
- UL Listed File No. IZLT.E35113
- CSA Certified File No. LR21455
- CE
- RoHS Compliant

30 & 60 Amp

200 Amp

- Clip, Copper Alloy, Tin Plated, with Patented Reject Member
- Patented Cool-Clip® Design
- Clip, One Piece Aluminum, Tin Plated, with Reject Pin

100 Amp

400 & 600 Amp

- Clip, Copper Alloy, Tin Plated with Reject Pin
- Clip, Copper Alloy, Tin Plated, with Reject Pin

250 Volts - Catalog #:

Replace "X" with # of poles

Standard	Reinforced	Poles (X)	Amps	Base Materials	Wire Range	Fuse Size	Fuses			
R30AXS	SAME	1/2/3	30	Thermoplastic	#10-#22 AWG CU	9/16" DIA BY 2"	A2D-R			
R30AXSP					#10-#14 AWG CU		A2K-R			
R30AXB					#6-#14 AWG CU		DLN-R			
R60AXSQ*					#10-#22 AWG CU		FLNR			
R60AXB					#2-#14 AWG CU #2-#12 AWG AL		FRN-R			
R100AXB		1/3	100	Phenolic	2/0-#14 AWG CU 2/0-#12 AWG AL	1" DIA BY 5 7/8"	KLNR			
R200AXBE					Polyester		250 kcmil - #6 AWG CU AL	1 1/2" DIA BY 7 1/8"	KTS-R	
R400AXB							Phenolic	(2) 350 kcmil - 1/0 AWG CU AL	2 13/32" DIA BY 8 5/8"	LLNRK
R600AXB								N/A	600	(2) 500 kcmil - 1/0 AWG CU AL
							TR-R			

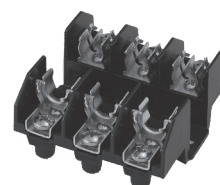

R30A3S

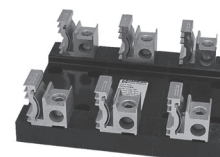

R200A3BE

*CSA Certified Only

600 Volts - Catalog #:

Replace "X" with # of poles

Standard	Reinforced	Poles (X)	Amps	Base Materials	Wire Range	Fuse Size	Fuses			
6R30AXS	SAME	1/2/3	30	Phenolic	#10-#22 AWG CU	13/16" DIA BY 5"	A6D-R			
6R30AXSP					#10-#14 AWG CU		A6K-R			
6R30AXB					#6-#14 AWG CU		DLS-R			
6R60AXB					#2-#14 AWG CU #2-#12 AWG AL		1 1/16" DIA BY 5 1/2"	FLSR		
6R100AXB					1/3		100	Phenolic	2/0-#14 AWG CU 2/0-#12 AWG AL	1 11/32" DIA BY 7 7/8"
6R200AXBE		Polyester	250 kcmil - #6 AWG CU AL	1 3/4" DIA BY 9 5/8"		FRS-R				
6R400AXB			Phenolic	(2) 350 kcmil - 1/0 AWG CU AL		2 29/32" DIA BY 11 5/8"			IDSR	
6R600AXB				N/A		600			(2) 500 kcmil - 1/0 AWG CU AL	
								LLSRK		
							LLSRK_ID			
							LPS-RK			
							TRS-R			



6R30A3B

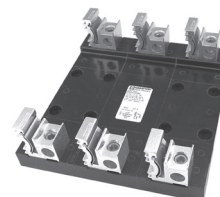

6R200A3BE

Contact Customer Service for Stud Options
See pages 13-15 for dimensional information

See pages 32-33 for available covers
See page 34 for DIN Rail Adapter

Marathon Special Products fuse holders will comply to new harmonized fuse holder standard 4248. Please refer to www.marathonsp.com for the latest updates.

Class H/K/R Fuse Holder Dimensions

	Figure	A	B	C	D	E	F	G	H	I	J	K	L	
F30A RF30A R30A	1 POLE 2 POLE 3 POLE	SEE FIGURE #1												
F60A RF60A R60A	1 POLE 2 POLE 3 POLE	FIG 2	4.83	1.48 2.86 4.23	2.01	1.24	1.8	.50	.49	1.33	N/A	N/A	.218 DIA THRU .40 DIA X .63 C'BORE	.11
RF100A R100A	1 POLE 2 POLE 3 POLE	FIG 2	6.12	1.93 3.49 5.05	2.44	2.37	1.87	.62	.61	1.56	N/A	N/A	.28 DIA THRU .53 DIA X .59 C'BORE	.36

mm = dim X 25.4

For electronic drawings or 2D/3D CAD data, send request to drawings@marathonsp.com

FIGURE 1:

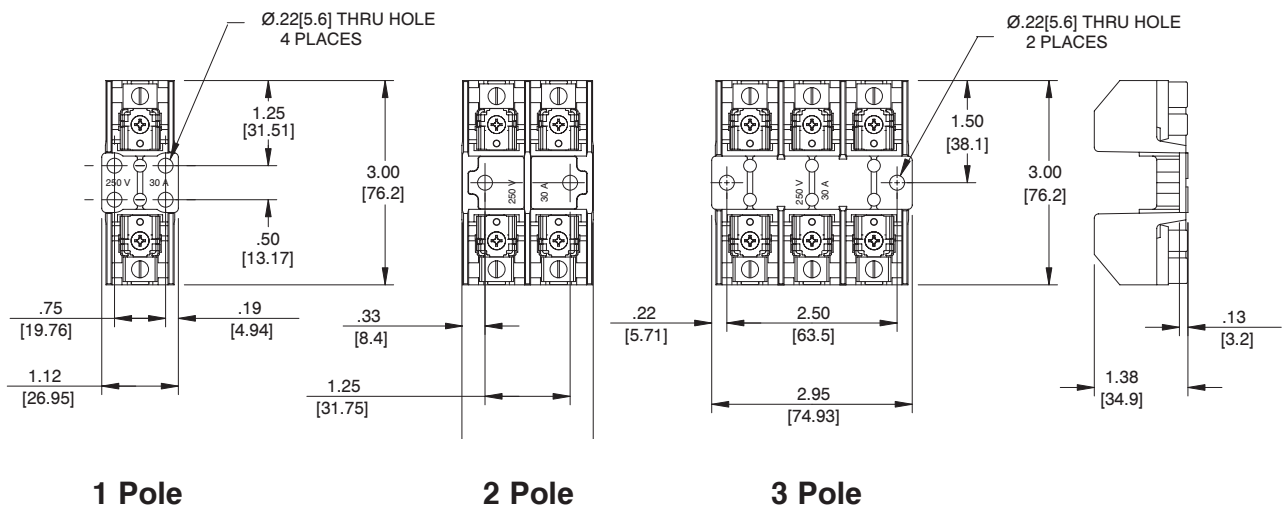
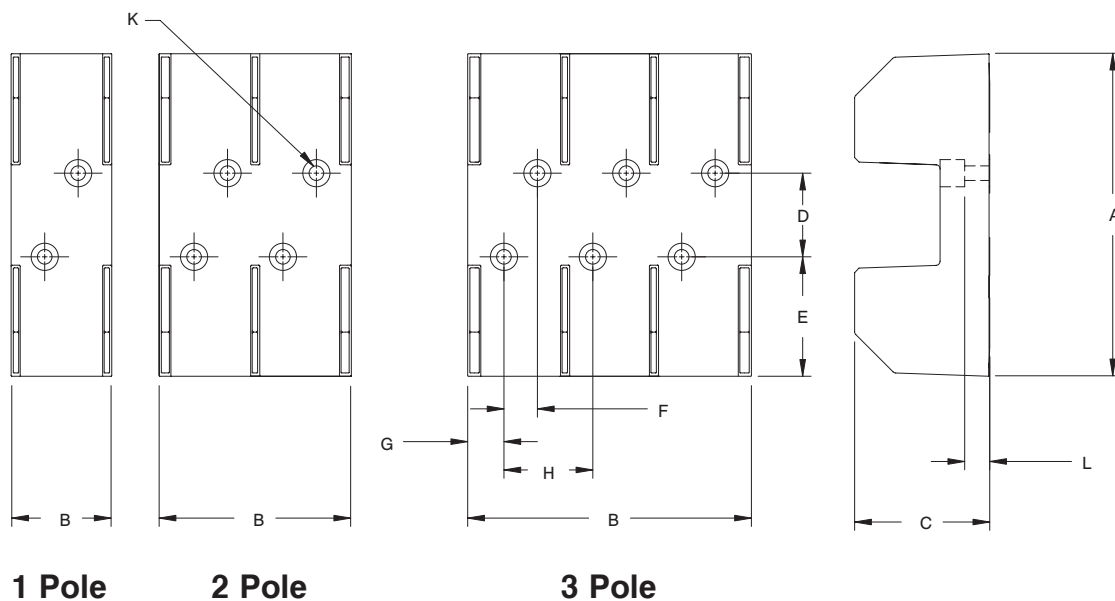

FIGURE 2:



Marathon Special Products fuse holders will comply to new harmonized fuse holder standard 4248. Please refer to www.marathonsp.com for the latest updates.

Class H/K/R Fuse Holder Dimensions

		Figure	A	B	C	D	E	F	G	H	I	J	K	L
6F30A	1 POLE			1.63				.31		.51	N/A	.34		
R6F30A	2 POLE	FIG 3	6.25	2.94	1.69	3.13	1.56	N/A	.62	.38	1.56	N/A	.28 DIA THRU	
6R30A	3 POLE			4.25				N/A		.25	3.13	N/A	.50 DIA X .44 C'BORE	.25
6F60A	1 POLE			1.95							N/A			
R6F60A	2 POLE	FIG 3	6.75	3.51	2.12	3.12	1.81	N/A	.62	.66	1.56	N/A	.28 DIA THRU	
6R60A	3 POLE			5.08							3.12	N/A	.50 DIA X .50 C'BORE	.33
R6F100A	1 POLE			2.10							N/A			
6R100A	2 POLE	FIG 3	8.12	3.91	2.60	4.26	1.94	N/A	.87	.61	1.81	N/A	.28 DIA THRU	
	3 POLE			5.73							3.62	N/A	.59 DIA X .64 C'BORE	.23
F200A	1 POLE	FIG 4	7.13	3.00	3.01	3.00	2.06	2.00	.50	8.00	N/A	N/A	.28 DIA THRU	
R200A	3 POLE			9.00									.63 DIA X .38 C'BORE	.26
6F200A	1 POLE	FIG 4	9.63	3.00	3.01	3.00	3.31	2.00	.5	8.00	N/A	N/A	.33 DIA THRU	
6R200A	3 POLE			9.00									.73 DIA X .44 C'BORE	.26

mm = dim X 25.4

For electronic drawings or 2D/3D CAD data, send request to drawings@marathonsp.com

FIGURE 3:

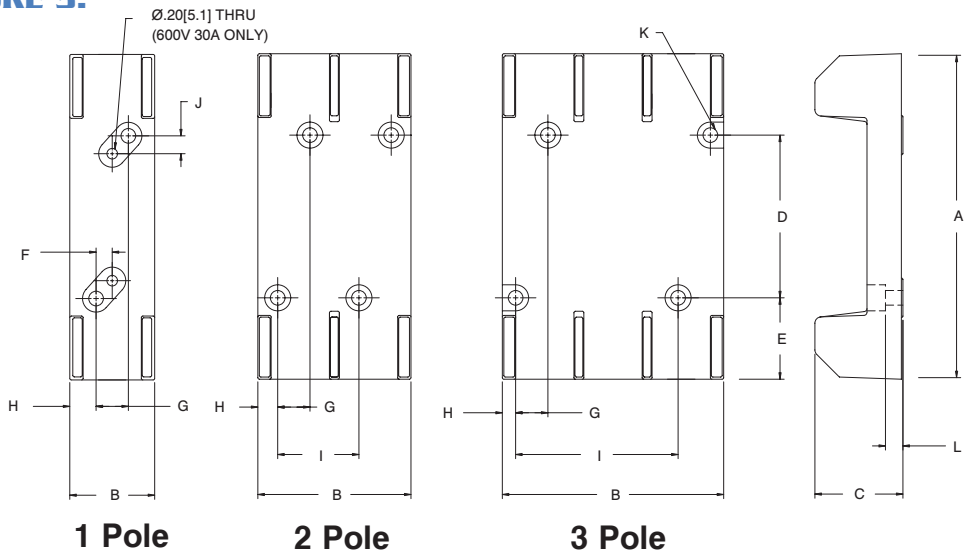
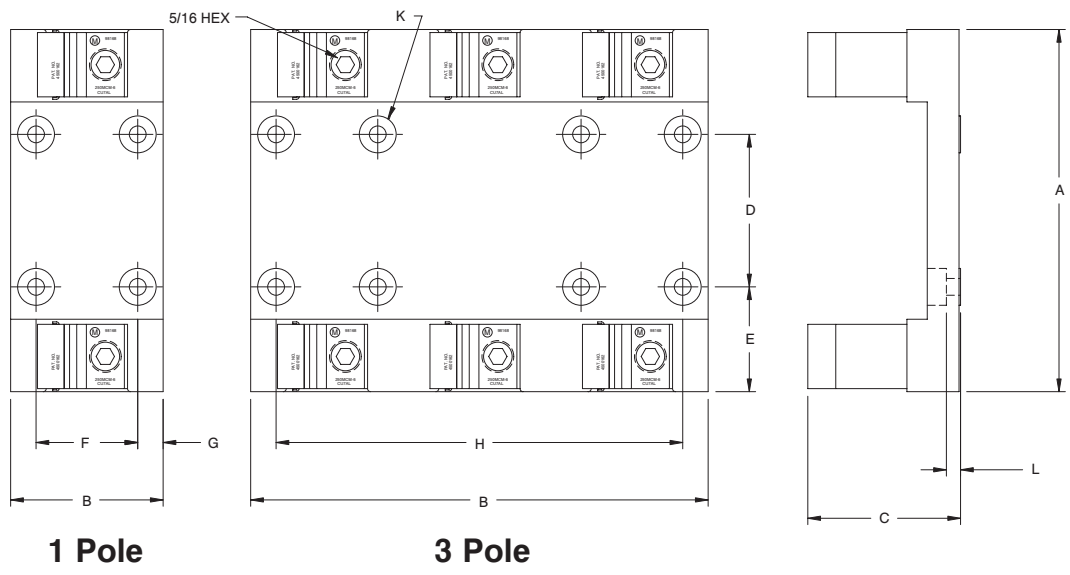

FIGURE 4:



Marathon Special Products fuse holders will comply to new harmonized fuse holder standard 4248. Please refer to www.marathonsp.com for the latest updates.

Class H/K/R Fuse Holder Dimensions

		Figure	A	B	C	D	E	F	G	H	I	J	K	L
RF400A R400A	1 POLE 3 POLE	FIG 5	11.5	3.5 10.5	3.31	4.00	3.75	2.25 9.25	.62	N/A	N/A	5/16 HEX	.28 DIA THRU .56 DIA X .44 C'BORE	.19
F600A R600A	1 POLE 3 POLE	FIG 5	14.00	4.5 12.5	4.31	5.00	4.50	3.00 11.00	.75	N/A	N/A	3/8 HEX	.28 DIA THRU .56 DIA X .44 C'BORE	.19
R6F400A 6R400A	1 POLE 3 POLE	FIG 5	14.50	3.50 10.50	3.31	7.00	3.75	2.25 9.25	.62	N/A	N/A	5/16 HEX	.28 DIA THRU .56 DIA X .44 C'BORE	.19
6F600A 6R600A	1 POLE 3 POLE	FIG 5	17.0	4.50 12.50	4.31	8.00	4.50	3.00 11.00	.75	N/A	N/A	3/8 HEX	.28 DIA THRU .56 DIA X .44 C'BORE	.19

mm = dim X 25.4

For electronic drawings or 2D/3D CAD data, send request to drawings@marathonsp.com

FIGURE 5:

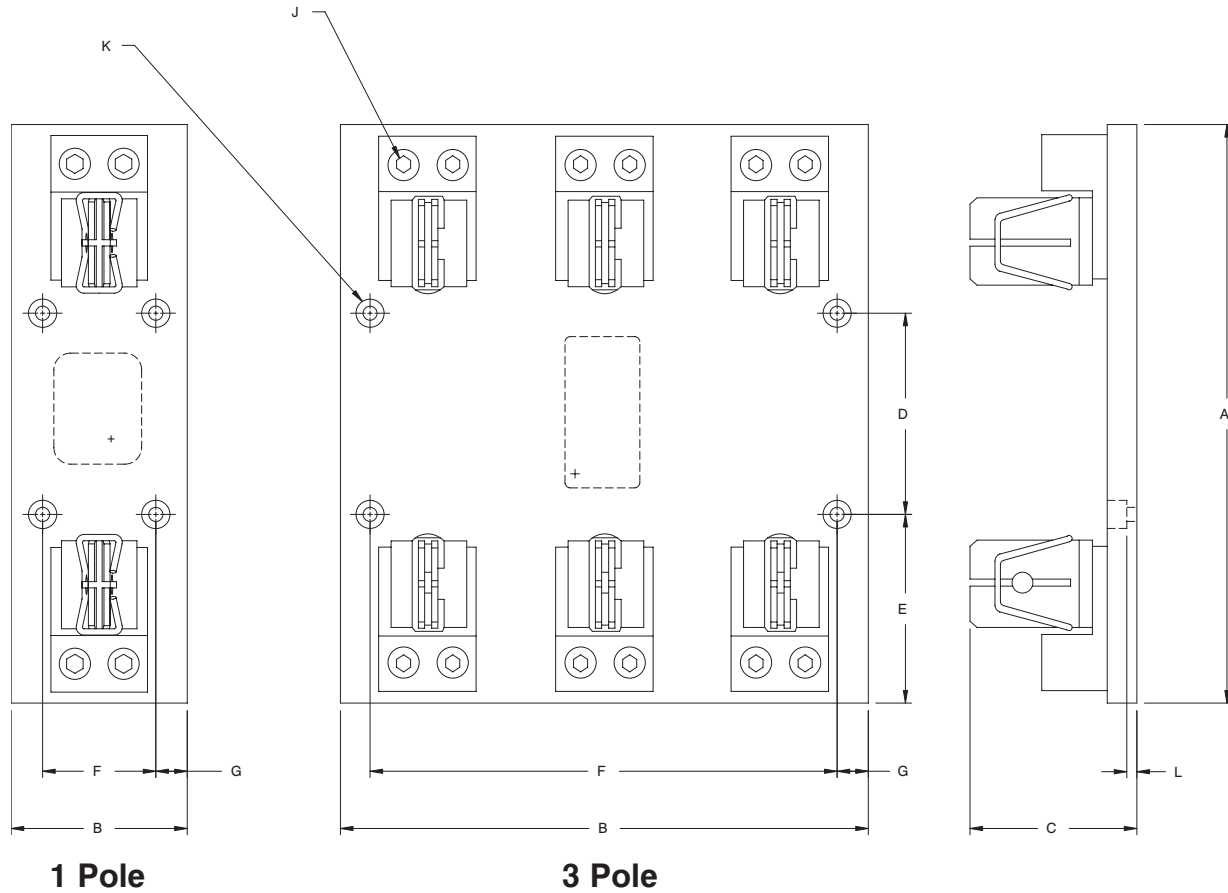

Marathon Special Products fuse holders will comply to new harmonized fuse holder standard 4248. Please refer to www.marathonsp.com for the latest updates.

Class T Fuse Holders - 300/600 Volt⁺

Specifications:

- Tested and Approved for 200,000 Amp Withstand Rating and Short Circuit Current Ratings (SCCR)
 - UL Listed File No. IZLT.E35113
 - CSA Certified File No. LR21455
 - CE
 - RoHS Compliant
- + Refer to www.marathonsp.com/PDFs/1000VCERating.pdf for details on availability of CE voltage ratings greater than 600 Volts

30 & 60 Amp

- Clip, Copper Alloy, Tin Plated
- Patented Cool-Clip® Design

200 Amp

- Connector, One Piece Aluminum with Integral Heat Sink, Tin Plated Bolt
- 5/16"-18 X 3/4" Hex Head, 5/16" Belleville Washer

100 Amp

- Connector, One Piece Aluminum with Integral Heat Sink, Tin Plated Bolt
- 1/4"-20 X 1/2" Bolt, 1/4" Belleville Washer

400 & 600 Amp

- Connector, One Piece Aluminum with Integral Heat Sink, Tin Plated Bolt
- 3/8"-16 X 3/4" Hex Head, 3/8" Belleville Washer

300 Volts - Catalog#:

Replace "X" with # of poles

Standard	Reinforced	Poles (X)	Amps	Base Materials	Wire Range	Fuse Size	Fuses
T30AXB	RT30AXB	2/3	30	Phenolic	#2-#14 AWG CU	13/32" DIA BY 7/8"	A3T J2N JLLN
T60AXB	RT60AXB		60		#2-#12 AWG AL	9/16" DIA BY 7/8"	
T100AXB	N/A	1/3	100		2/0-#14 AWG CU	13/16" DIA BY 2 5/32"	
T200AXB			200		250 kcmil - #6 AWG CU AL	1 1/16" DIA BY 2 7/16"	
T400AXB	N/A	1	400		(2) 250 kcmil - #6 AWG CU AL	1 11/32" DIA BY 2 3/4"	
T600AXB			600		(2) 500 kcmil - #6 AWG CU AL	1 39/64" DIA BY 3 1/16"	



T30A3B



RT60A3B

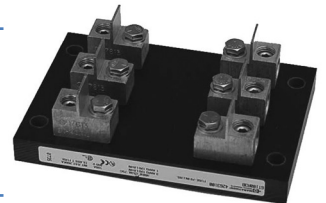

6T100A3B

600 Volts - Catalog#:

Replace "X" with # of poles

Standard	Reinforced	Poles (X)	Amps	Base Materials	Wire Range	Fuse Size	Fuses
6T30AXS	R6T30AXS	2/3	30	Phenolic	#10-#22 AWG CU	9/16" DIA BY 1 1/2"	A6T JJS JLLS
6T30AXSP	R6T30AXSP				#10-#14 AWG CU		
6T30AXB	R6T30AXB				#2-#14 AWG CU		
R6T60AXB	SAME	60	#2-#12 AWG AL		13/16" DIA BY 1 9/16"		
6T100AXB	N/A	1/3	100		2/0-#14 AWG CU	13/16" DIA BY 2 61/64"	
6T200AXB			200		250 kcmil - #6 AWG CU AL	1 1/16" DIA BY 3 1/4"	
6T400AXB	N/A	1	400		(2) 250 kcmil - #6 AWG CU AL	1 39/64" DIA BY 3 5/8"	
6T600AXB			600		(2) 500 kcmil - #6 AWG CU AL	2 5/64" DIA BY 3 63/64"	



6T30A3SP



R6T60A3B

See pages 17-18 for dimensional information

Marathon Special Products fuse holders will comply to new harmonized fuse holder standard 4248. Please refer to www.marathonsp.com for the latest updates.

Class T Fuse Holder Dimensions

		Figure	A	B	C	D	E	F	G	H	I	J
T30A RT30A	2 POLE 3 POLE	FIG 1	1.12	SEE FIGURE #1								
T60A RT60A	2 POLE 3 POLE	FIG 1	1.28	SEE FIGURE #1								
T100A	1 POLE 3 POLE	FIG 2	5.25	1.37 4.12	1.87	4.50	0.38	0.69	N/A 2.75	0.20 THRU 0.37 DIA X .44 C'BORE	3/16 HEX	.19
T200A	1 POLE 3 POLE	FIG 2	7.00	1.50 4.50	2.25	6.25	0.38	0.75	N/A 3.00	0.28 THRU 0.50 DIA X .44 C'BORE	5/16 HEX	.19
6T100A	1 POLE 3 POLE	FIG 2	6.06	1.37 4.12	1.87	5.31	0.38	0.69	N/A 2.75	0.20 THRU 0.37 DIA X .44 C'BORE	3/16 HEX	.19
6T200A	1 POLE 3 POLE	FIG 2	7.75	1.50 4.50	2.25	7.00	0.38	0.75	N/A 3.00	0.28 THRU 0.50 DIA X .44 C'BORE	5/16 HEX	.19

mm = dim X 25.4

For electronic drawings or 2D/3D CAD data, send request to drawings@marathonsp.com

FIGURE 1:

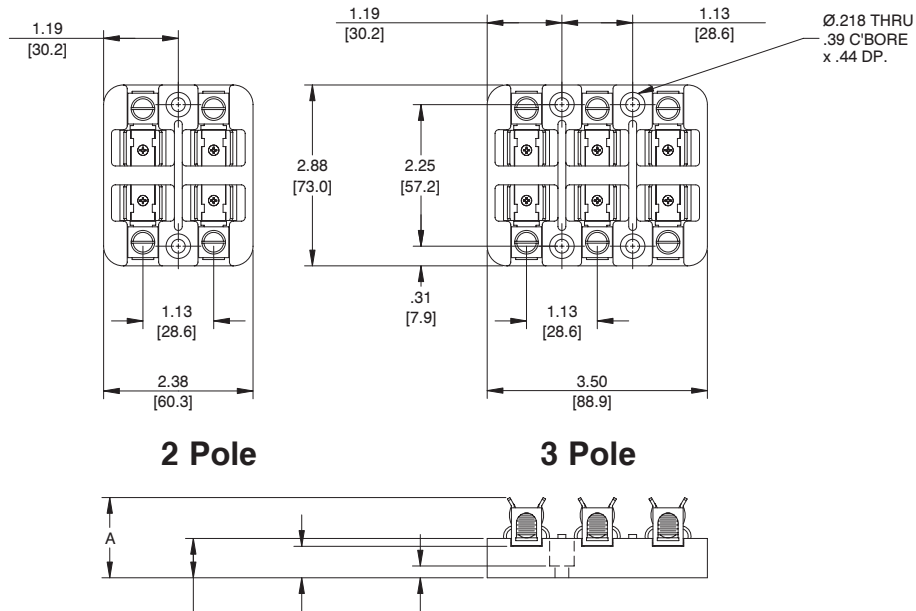
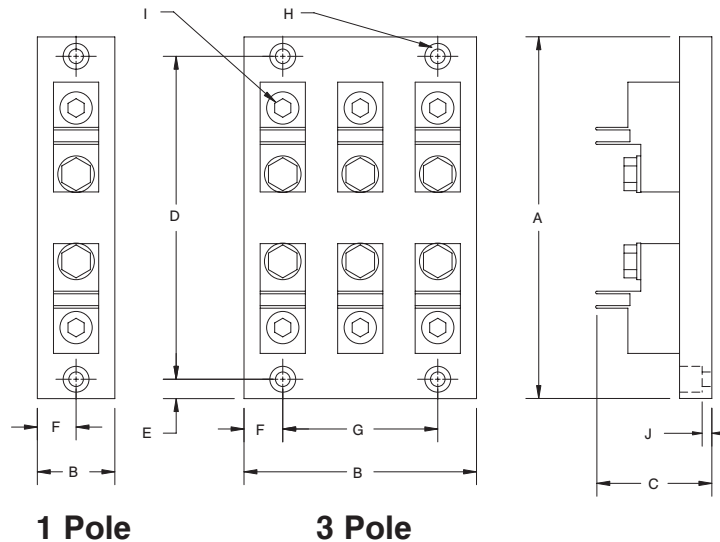

FIGURE 2:



Marathon Special Products fuse holders will comply to new harmonized fuse holder standard 4248. Please refer to www.marathonsp.com for the latest updates.

Class T Fuse Holder Dimensions

		Figure	A	B	C	D	E	F	G	H	I	J
T400A	1 POLE	FIG 3	8.12	2.25	2.37	7.37	0.38	1.12	N/A	0.28 THRU 0.50 DIA X .44 C'BORE	N/A	.19
6T400A	1 POLE	FIG 3	9.00	2.25	2.37	8.25	0.38	1.12	N/A	0.28 THRU 0.50 DIA X .44 C'BORE	N/A	.19
T600A	1 POLE	FIG 4	8.75	2.75	2.62	8.06	0.34	0.38	2.00	0.28 THRU 0.50 DIA X .44 C'BORE	N/A	.19
6T600A	1 POLE	FIG 4	9.75	2.75	2.62	9.00	0.38	0.38	2.00	0.28 THRU 0.50 DIA X .44 C'BORE	N/A	.19
6T30A R6T30A	2 POLE 3 POLE	FIG 5	1.28	SEE FIGURE #5								
R6T60A	2 POLE 3 POLE	FIG 5	1.74	SEE FIGURE #5								

mm = dim X 25.4

For electronic drawings or 2D/3D CAD data, send request to drawings@marathonsp.com

FIGURE 3:

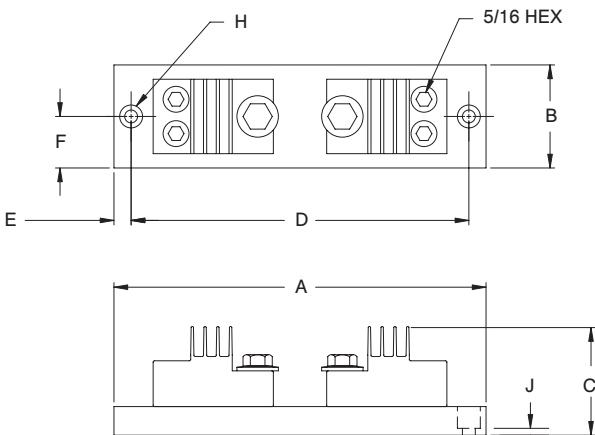

FIGURE 4:

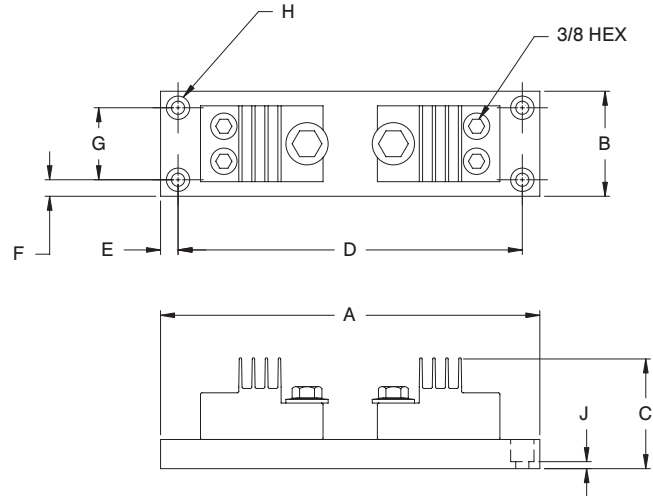
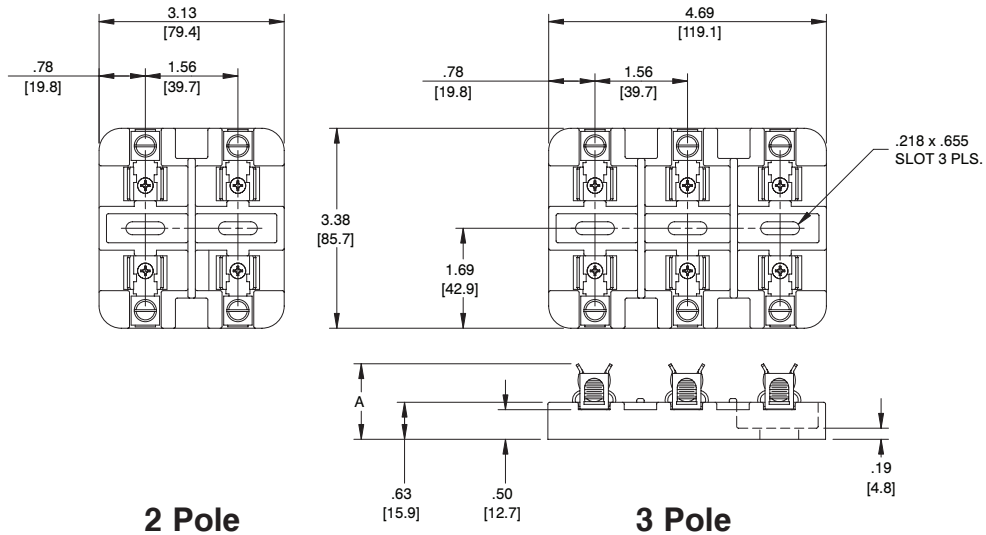

FIGURE 5:



Marathon Special Products fuse holders will comply to new harmonized fuse holder standard 4248. Please refer to www.marathonsp.com for the latest updates.

Class J Fuse Holders - 600 Volt⁺

Specifications:

- Tested and Approved for 200,000 Amp Withstand Rating and Short Circuit Current Ratings (SCCR)
- UL Listed File No. IZLT.E35113
- CSA Certified File No. LR21455
- **CE**
- RoHS Compliant

+ Refer to www.marathonsp.com/PDFs/1000VCERating.pdf for details on availability of CE voltage ratings greater than 600 Volts

30 & 60 Amp

- Clip, Copper Alloy, Tin Plated
- Patented Cool-Clip[®] Design
- Integral DIN Rail Mount and Expander Block (Available only on 30 Amp)

200 Amp

- Connector, One Piece Aluminum, Tin Plated (Optional One Piece Copper, Nickel Plated - Add "CU") - Consult Customer Service
- FBD, Fuse Bolt-Down Construction

100 Amp

- Clip, Copper Alloy, Tin Plated
- 1-Pole Molding Incorporates a Dovetail Feature for Ganging Multiple Poles

400 & 600 Amp

- Connector, One Piece Aluminum, Tin Plated (Optional One Piece Copper, Nickel Plated - Add "CU") - Consult Customer Service
- FBD, Fuse Bolt-Down Construction

Catalog #:

Replace "X" with # of poles (E = Expander)

Standard	Reinforced	Poles (X)	Amps	Base Materials	Wire Range	Fuse Size	Fuses
6J30AXS	R6J30AXS	1/2/3/E	30	Thermoplastic	#10-#22 AWG CU	13/16" DIA BY 2 1/4"	A4J AJT JKS
6J30AXSP	R6J30AXSP				#10-#14 AWG CU		
6J30AXB	R6J30AXB				#6-#14 AWG CU		
6J60AXB	R6J60AXB	1/2/3	60	Phenolic	#2-#14 AWG AL	1 1/16" DIA BY 2 3/8"	JLS JTD JTD_ID LPJ
R6J100AXB	SAME	1	100		2/0-#14 AWG CU	1 1/8" DIA BY	
6J200AXBFBFD		3			2/0-#12 AWG AL	4 5/8"	
6J400AXBFBFD		1/3	400	350 kcmil - #6 AWG CU AL	1 5/8" DIA BY 5 3/4"		
6J600AXBFBFD		600	(1) 350 kcmil - #6 AWG CU AL (1) 600 kcmil - #2 AWG CU AL	2 1/8" DIA BY 7 1/8"			
				(2) 500 kcmil - #4 AWG CU AL	2 5/8" DIA BY 8"		



R6J30A3S



6J60A3B

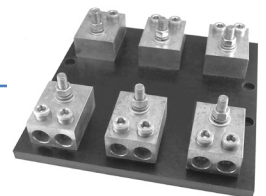

6J600A3BFBFD

Contact Customer Service for Stud Options - see pages 20-21 for dimensional information
Fuse Mounting hardware supplied with fuse holder
See pages 32-33 for available covers

DIMENSIONS		Figure	A	B	C	D	E	F	G	H	M	EXPANDER
6J30A R6J30A	1 POLE 2 POLE 3 POLE	FIG 1 (p. 20)	3.38	1.16 2.20 3.25	1.95	1.69	1.04	0.30	0.57	.22 X .79 SLOT	0.24	YES
6J200A	1 POLE 3 POLE	SEE FIGURE #2 (page 20)										
6J60A R6J60A	1 POLE 2 POLE 3 POLE	SEE FIGURE #3 (page 20)										
6J400A	1 POLE 3 POLE	SEE FIGURE #4 (page 21)										
6J600A	1 POLE 3 POLE	SEE FIGURE #5 (page 21)										
R6J100A	1 POLE 3 POLE	SEE FIGURE #6 (page 21)										

For electronic drawings or 2D/3D CAD data, send request to drawings@marathonsp.com

mm = dim X 25.4

Marathon Special Products fuse holders will comply to new harmonized fuse holder standard 4248. Please refer to www.marathonsp.com for the latest updates.

Class J Fuse Holder Dimensions

FIGURE 1:

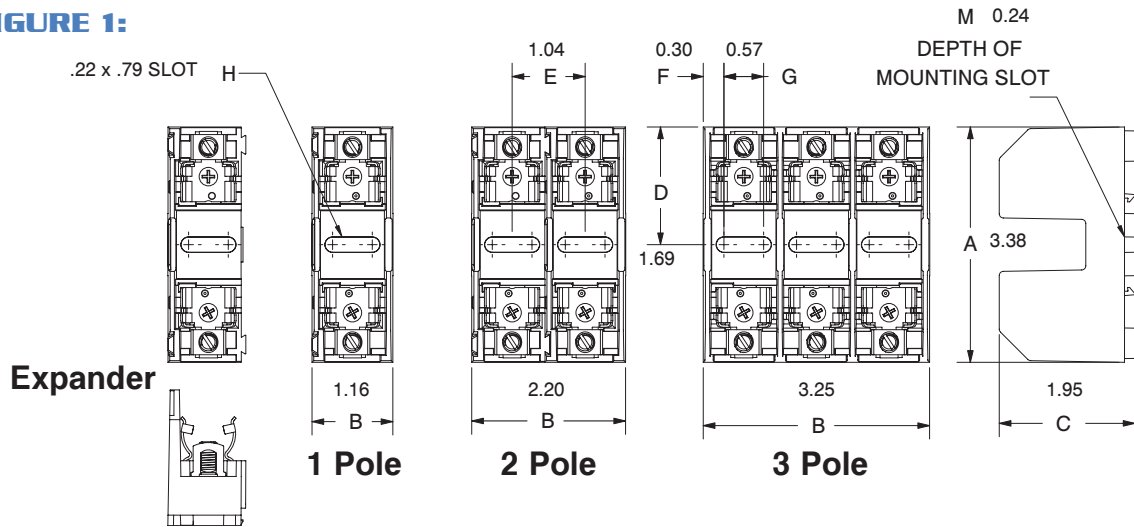

FIGURE 2:

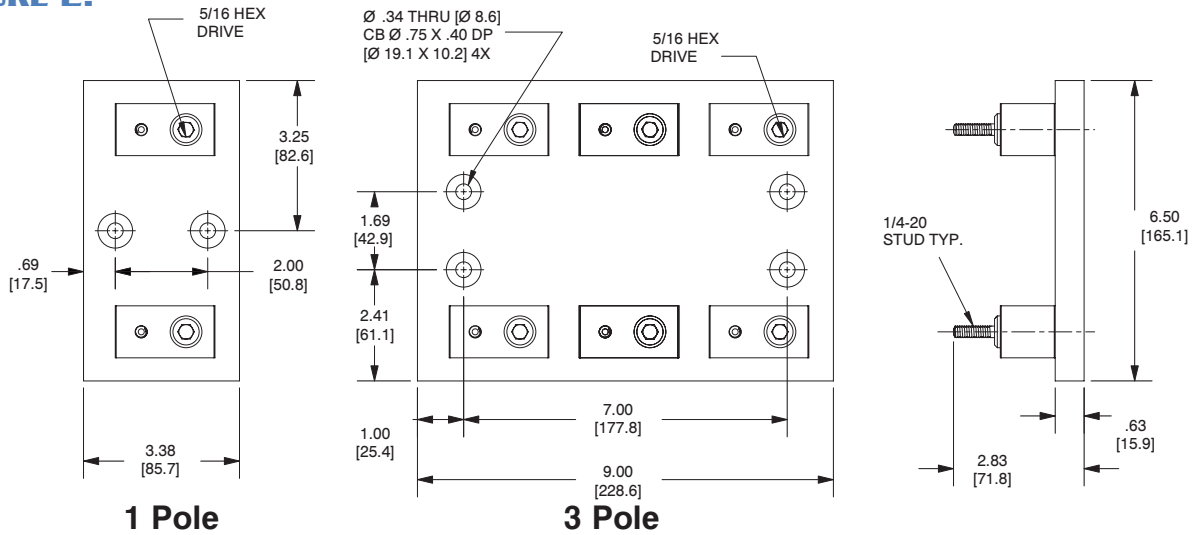
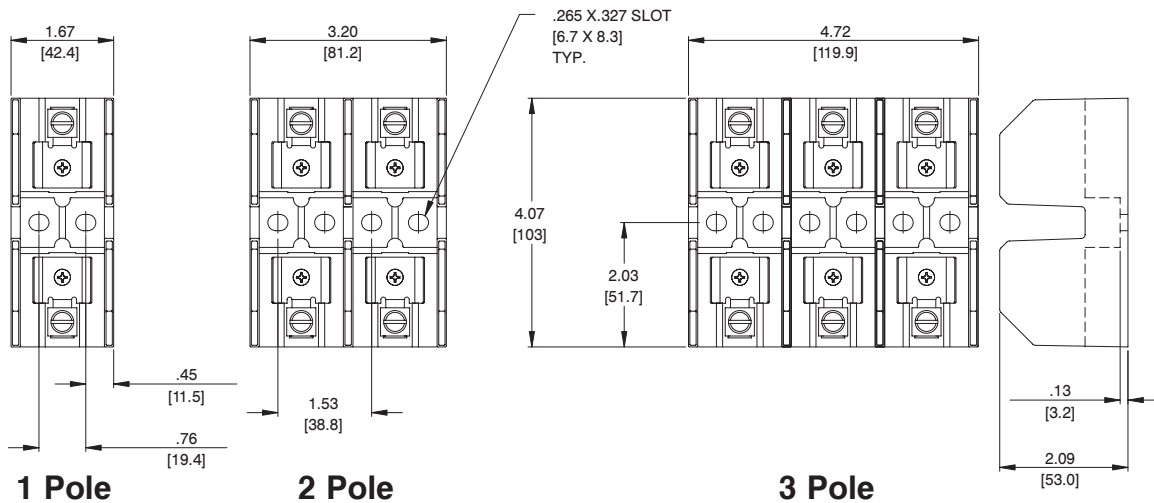

FIGURE 3:



Marathon Special Products fuse holders will comply to new harmonized fuse holder standard 4248. Please refer to www.marathonsp.com for the latest updates.

For electronic drawings or 2D/3D CAD data, send request to drawings@marathonsp.com

Class J Fuse Holder Dimensions

FIGURE 4:

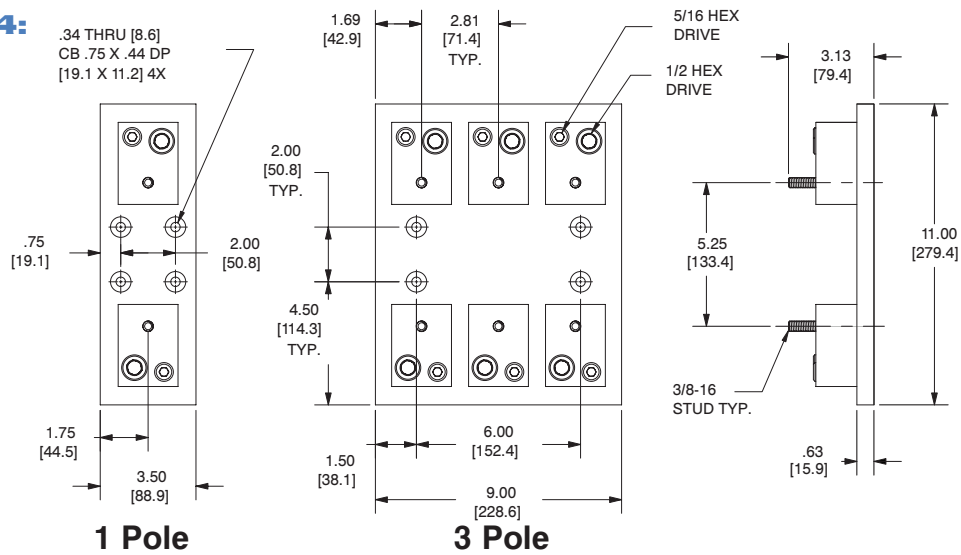

FIGURE 5:

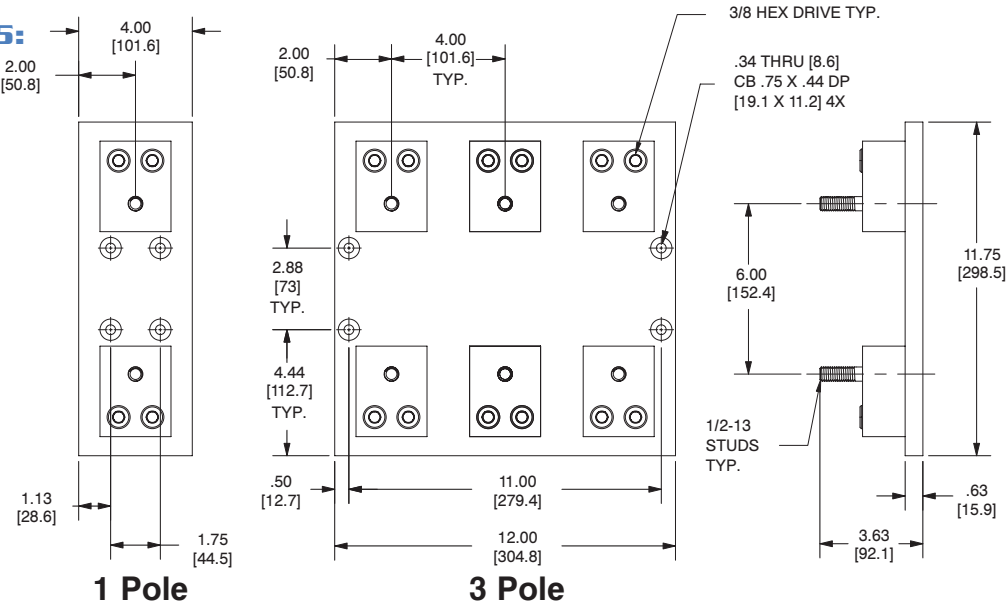
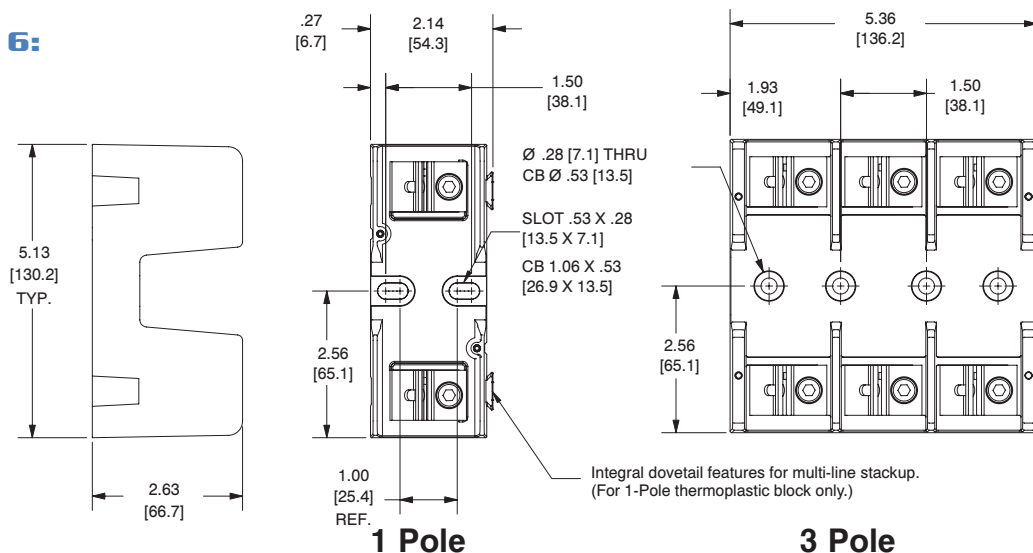

FIGURE 6:



Marathon Special Products fuse holders will comply to new harmonized fuse holder standard 4248. Please refer to www.marathonsp.com for the latest updates.

For electronic drawings or 2D/3D CAD data, send request to drawings@marathonsp.com

M Fuse Holders - 600 Volt⁺

Specifications:

- Tested and Approved for 100,000 Amp Withstand Rating and Short Circuit Current Ratings (SCCR)
- Clip, Copper Alloy, Tin Plated
- Quick Connect Standard with Screw (S) or Sems Pressure (SP)
- UL Recognized File No. IZLT2.E35113
- CSA Certified File No. LR21455
- **CE** - Rated for 1000 Volts
- RoHS Compliant

+ Refer to www.marathonsp.com/PDFs/1000VCERating.pdf for details on availability of CE voltage ratings greater than 600 Volts



6M30A3SPQ



6M30A3B

Catalog #:

Replace "X" with # of poles

Standard	Reinforced	Poles (X)	Amps	Base Materials	Wire Range	Fuse Size	Fuses
6M30AXSQ	N/A	1/2/3	30	Thermoplastic	#10-#22 AWG CU	13/32" DIA BY 1 1/2"	A13X-2, A25Z-2, A60Q-2, A6Y-2B, AGU, ATM, ATQ, BAF, BAN, BLF, BLN, BLS, FLA, FLM, FLQ, FNM, FNQ, GFN, GGO, KLK, KLKD, KLQ, KTK, OTM, TRM
6M30AXSPQ					#10-#14 AWG CU		
6M30AXB					#6-#14 AWG CU		
6M30AXBCU							

See pages 32-33 for available covers
See page 34 for DIN Rail Adapter

For electronic drawings or 2D/3D CAD data,
send request to drawings@marathonsp.com

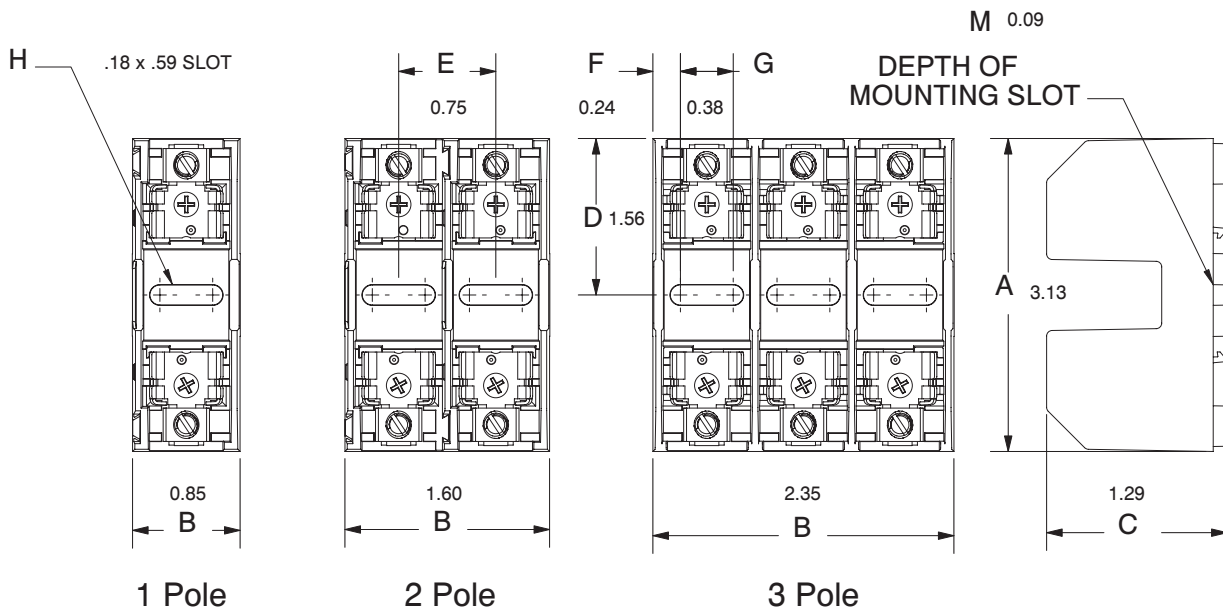

mm = dim X 25.4

Marathon Special Products fuse holders will comply to new harmonized fuse holder standard 4248. Please refer to www.marathonsp.com for the latest updates.

Midget Enclosed Fuse Holders - 600 Volt⁺

Specifications:

- Tested and Approved for 100,000 RMS Symmetrical Amps Withstand Rating and Short Circuit Current Ratings (SCCR)
- Touchsafe Design IEC Type IP20
- DIN Rail Mount (35mm)
- Blown Fuse Indication Available
- Handle Allows Quick Easy Fuse Change
- AC & DC Rated
- Indication light AC and DC - 80 Volts Minimum
- UL Recognized File No. IZLT2.E35113
- CSA Certified File No. LR21455
- **CE**
- RoHS Compliant

+ Refer to www.marathonsp.com/PDFs/1000VCERating.pdf for details on availability of CE voltage ratings greater than 600 Volts



6SM30A1-B shown with fuse (fuse not included)

6SM30A1-B (non-indicating)

6SM30A3I-B (indicating)

Catalog #	Indicating	Poles	Amps	Base Materials	Wire Range	Fuse Size	Fuses
6SM30A1-B	No	1	30	Thermoplastic	#6-#14 AWG CU	13/32" DIA BY 1 1/2"	A13X-2, A25Z-2,
6SM30A2-B		2					A60Q-2, A6Y-2B, AGU,
6SM30A3-B		3					ATM, ATQ, BAF, BAN,
6SM30A4-B		4					BLF, BLN, BLS, FLA,
6SM30A11-B	Yes	1	30	Thermoplastic	#6-#14 AWG CU	13/32" DIA BY 1 1/2"	FLM, FLQ, FNM, FNQ,
6SM30A2I-B		2					GFN, GGO, KLK,
6SM30A3I-B		3					KLKD, KLQ, KTK,
6SM30A4I-B		4					OTM, TRM

For electronic drawings or 2D/3D CAD data, send request to drawings@marathonsp.com

Dimensions	mm	Inches
A	17.8	0.70
B	35.6	1.40
C	53.3	2.10
D	71.1	2.80
E	43.2	1.70
F	59.7	2.35
G	12.2	0.48
H	77.2	3.04

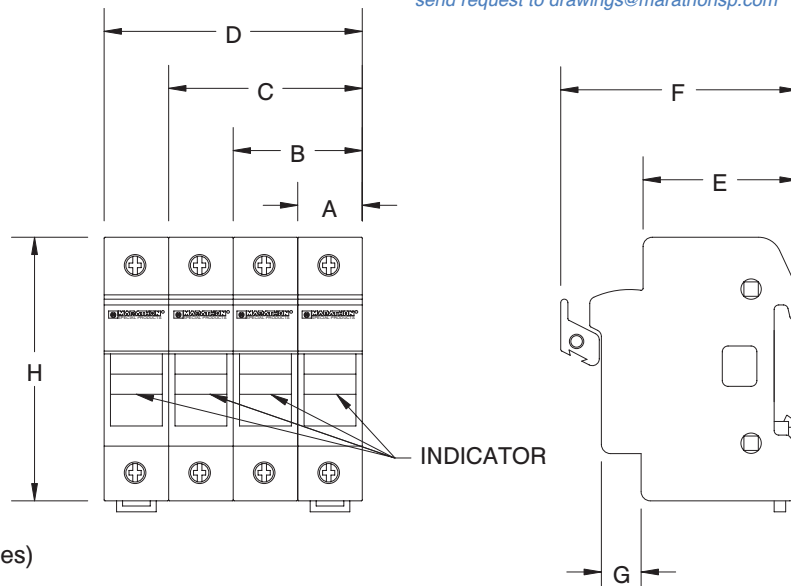

Pin Kit (used for ganging multiple poles)

Catalog Description:
EFH-MCCK

- *Includes 10 handle pins and 20 body clips
- *Use one handle pin and two body clips per pole

Marathon Special Products fuse holders will comply to new harmonized fuse holder standard 4248. Please refer to www.marathonsp.com for the latest updates.

Midget Fuse Holders - 600 Volt

30 Amp Sectional Version

Specifications:

- Tested and Approved for 10,000 Amp Withstand Rating and Short Circuit Current Ratings (SCCR)
- Base, White Nylon - Type 6/6, 105°C
- Connector Box Type
- Accepts up to #10 AWG Wire, either Terminated or Non-Terminated
- Clip, Copper Alloy, Tin Plated
- UL Recognized File No. IZLT2.E35113
- CSA Certified File No. LR21455
- **CE**
- RoHS Compliant

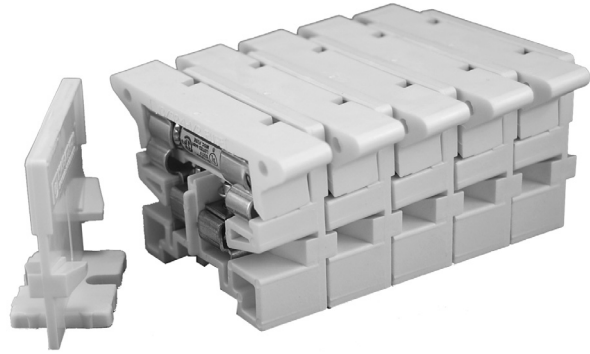

6W30A1F with end piece (fuse not included)

Standard	Description	Std Pack	Wire Range	Fuse Size	Fuses
6W30A1F	Flat Mount	10	#10-#14 AWG CU STRANDED	13/32" DIA BY 1 1/2" LONG	A13X-2, A25Z-2, A60Q-2, A6Y-2B, AGU, ATM, ATQ, BAF, BAN, BLF, BLN, BLS, FLA, FLM, FLQ, FNM, FNQ, GFN, GGO, KLK, KLKD, KLQ, KTK, OTM, TRM
6W30A1C	Channel Mount				
6WEF	End Piece (flat)				
6WEC	End Piece (channel)				
MC	Mounting Clamp	25			
MPC-6	6 Foot Channel	-			
MPC-3	3 Foot Channel				
GR-2	1/8" Diameter X 2' Long Nylon Rod				

For electronic drawings or 2D/3D CAD data, send request to drawings@marathonsp.com

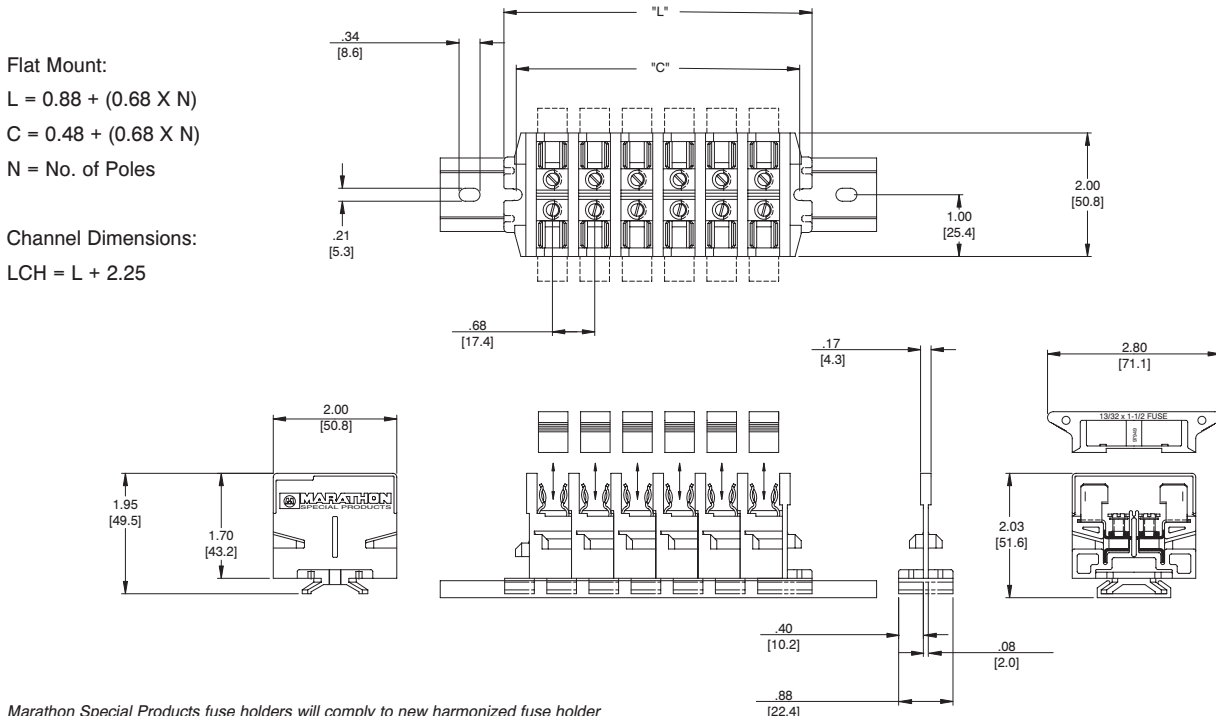

Marathon Special Products fuse holders will comply to new harmonized fuse holder standard 4248. Please refer to www.marathonsp.com for the latest updates.

CC Fuse Holders - 600 Volt

Specifications:

30 Amp

- Tested and Approved for 200,000 Amp Withstand Rating and Short Circuit Current Ratings (SCCR)
- Clip, Copper Alloy, Tin Plated with Patented Reject Member
- Quick Connect Standard with Screw (S) or Sems Pressure (SP)
- UL Listed File No. IZLT.E35113
- CSA Certified File No. LR21455
- **CE**
- RoHS Compliant

60 Amp

- Tested and Approved for 200,000 Amp Withstand Rating and Short Circuit Current Ratings (SCCR)
- Patented Cool-Clip® Design
- Clip, Copper Alloy, Tin Plated
- Integral DIN Rail Mount
- Expander Block Available
- UL Listed File No. IZLT2.E35113, Class CD
- CSA Certified File No. LR21455-91
- **CE**
- RoHS Compliant



6CC30A3SQ



6CC30A3B



R6CC60A3B

Catalog #:

Replace "X" with # of poles (E = Expander)

Standard	Reinforced	Poles (X)	Amps	Base Materials	Wire Range	Fuse Size	Fuses
6CC30AXSQ	N/A	1/2/3	30	Thermoplastic	#10-#22 AWG CU	13/32" DIA BY 1 1/2"	ATDR
6CC30AXSPQ					#10-#14 AWG CU		ATMR
6CC30AXB					#6-#14 AWG CU		ATQR
6CC30AXBCU						CCMR	
R6CC60AXB	SAME	1/2/3/E	60		#2-#14 AWG CU #2-#12 AWG AL	0.70" DIA BY 1.85"	FRQ-R KLDL, KLKR, KTK-R, LP-CC

See pages 32-33 for available covers

See page 34 for DIN Rail Adapter

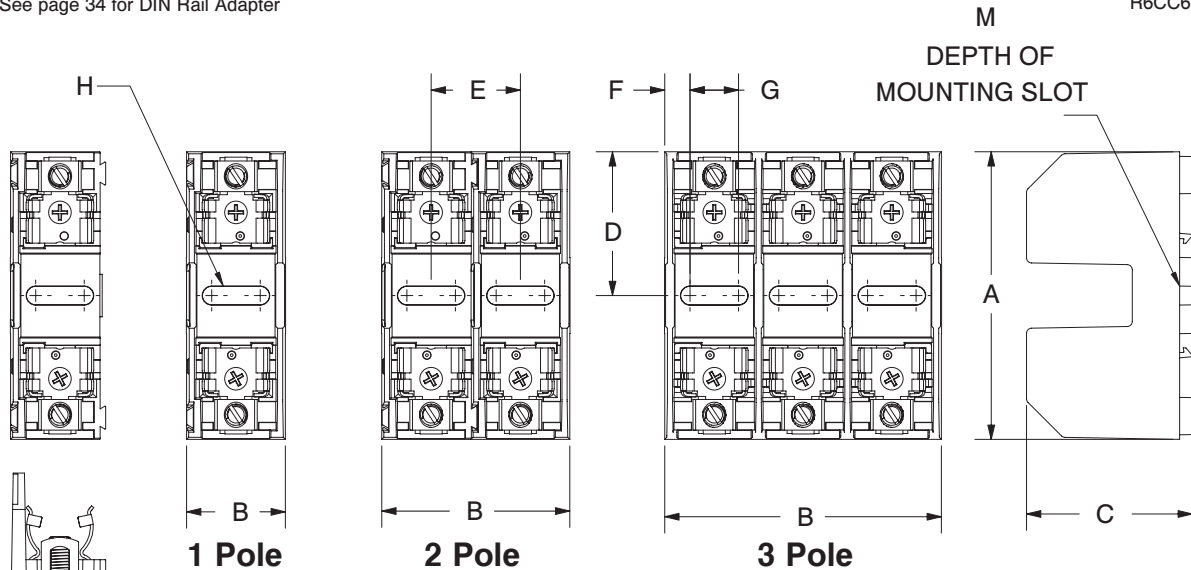

Expander

DIMENSIONS		A	B	C	D	E	F	G	H	M	EXPANDER
6CC30A	1 POLE	3.13	0.85	1.29	1.56	0.75	0.24	0.38	.18 X .59 SLOT	0.09	NO
	2 POLE		1.60								
	3 POLE		2.35								
R6CC60A	1 POLE	3.35	1.11	1.89	1.68	1.01	0.27	0.57	.18 X .74 SLOT	0.09	YES
	2 POLE		2.12								
	3 POLE		3.12								

mm = dim X 25.4

For electronic drawings or 2D/3D CAD data, send request to drawings@marathonsp.com

Marathon Special Products fuse holders will comply to new harmonized fuse holder standard 4248. Please refer to www.marathonsp.com for the latest updates.

Datasheets available at marathonsp.com

Class CC Enclosed Fuse Holders - 600 Volt

Specifications:

- Tested and Approved for 200,000 RMS Symmetrical Amps Withstand Rating and Short Circuit Current Ratings (SCCR)
- Touchsafe Design IEC Type IP20
- DIN Rail Mount (35mm)
- Blown Fuse Indication Available
- Handle Allows Quick Easy Fuse Change
- Indication light AC and DC - 80 Volts Min.
- UL Listed File No. IZLT2.E35113
- CSA Certified File No. LR21455
- **CE**
- RoHS Compliant



6SC30A1-B shown with fuse (fuse not included)



6SC30A1-B



6SC30A3I-B

Catalog #	Indicating	Poles (X)	Amps	Base Materials	Wire Range	Fuse Size	Fuses
6SC30A1-B	No	1	30	Thermoplastic	#6-#14 AWG CU	13/32" DIA BY 1 1/2"	ATDR
6SC30A2-B		2					ATMR
6SC30A3-B		3					ATQR
6SC30A4-B		4					CCMR
6SC30A1I-B	Yes	1					FRQ-R
6SC30A2I-B		2					KLDR
6SC30A3I-B		3					KLKR
6SC30A4I-B		4					KTK-R, LP-CC

For electronic drawings or 2D/3D CAD data, send request to drawings@marathonsp.com

Dimensions	mm	Inches
A	17.8	0.70
B	35.6	1.40
C	53.3	2.10
D	71.1	2.80
E	43.2	1.70
F	59.7	2.35
G	12.2	0.48
H	77.2	3.04

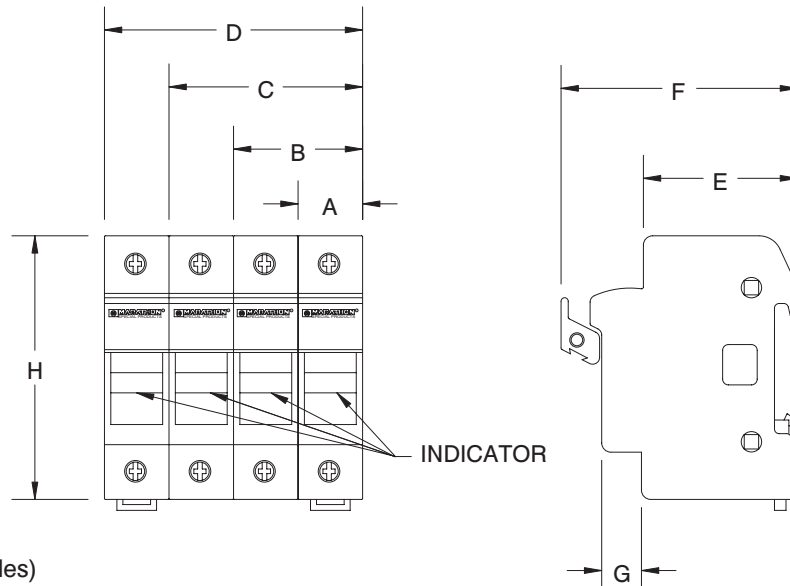

Pin Kit (used for ganging multiple poles)

Catalog Description:
EFH-MCCK

- *Includes 10 handle pins and 20 body clips
- *Use one handle pin and two body clips per pole

Marathon Special Products fuse holders will comply to new harmonized fuse holder standard 4248. Please refer to www.marathonsp.com for the latest updates.

Class G Fuse Holders

Specifications:

- Tested and Approved for 100,000 Amp Withstand Rating and Short Circuit Current Ratings (SCCR)
- Clip, Copper Alloy, Tin Plated
- Quick Connect Standard with Screw (S) or Sems Pressure (SP)
- UL Listed File No. IZLT.E35113
- CSA Certified File No. LR21455
- CE
- RoHS Compliant

1/2 - 15 Amps (600 Volt)

Replace "X" with # of poles

Catalog #		Poles (X)	Amps	Base Materials	Wire Range	Fuse Size	Fuses
Standard	Reinforced						
G15AXSQ	RG15AXSQ	1/2/3	15	Thermoplastic	#10-#22 AWG CU	13/32" DIA BY 1 5/16"	AG
G15AXSPQ	RG15AXSPQ				#10-#14 AWG CU		SC
G15AXB	RG15AXB				#6-#14 AWG CU		SLC
G15AXBCU	RG15AXBCU						



G15A3SPQ

20 Amps (600 Volt)

Catalog #		Poles (X)	Amps	Base Materials	Wire Range	Fuse Size	Fuses
Standard	Reinforced						
G20AXSQ	RG20AXSQ	1/2/3	20	Thermoplastic	#10-#22 AWG CU	13/32" DIA BY 1 13/32"	AG
G20AXSPQ	RG20AXSPQ				#10-#14 AWG CU		SC
G20AXB	RG20AXB				#6-#14 AWG CU		SLC
G20AXBCU	RG20AXBCU						



G20A3SQ

25-30 Amps (480 Volt)

Catalog #		Poles (X)	Amps	Base Materials	Wire Range	Fuse Size	Fuses
Standard	Reinforced						
G30AXSQ	RG30AXSQ	1/2/3	30	Thermoplastic	#10-#22 AWG CU	13/32" DIA BY 1 5/8"	AG
G30AXSPQ	RG30AXSPQ				#10-#14 AWG CU		SC
G30AXB	RG30AXB				#6-#14 AWG CU		SLC
G30AXBCU	RG30AXBCU						



G30AXB

See pages 32-33 for available covers
See page 34 for DIN Rail Adapter

For electronic drawings or 2D/3D CAD data,
send request to drawings@marathonsp.com

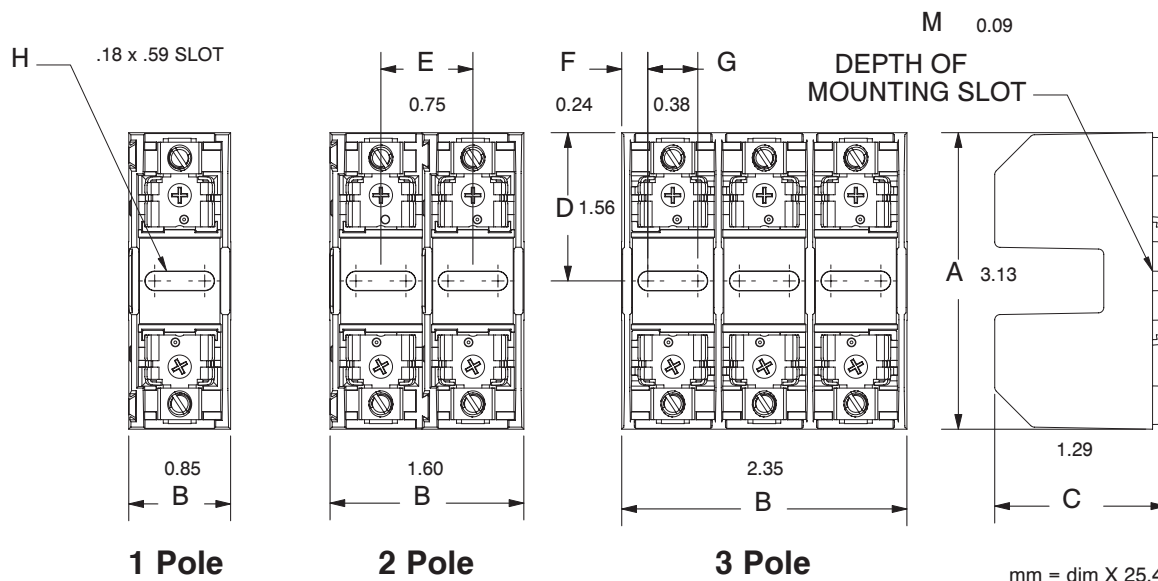

Marathon Special Products fuse holders will comply to new harmonized fuse holder standard 4248. Please refer to www.marathonsp.com for the latest updates.

Semi Conductor Fuse Holders

1000 Volt

Box Version - Specifications:

- Tested and Approved for 200,000 Amp, 600 Volt Withstand Rating and Short Circuit Current Ratings (SCCR)
- Insulator Base, General Purpose Phenolic, 150°C
- Hex-Head Bolts and Belleville Washers Provided Unassembled
- Connector - Aluminum, Tin Plated
- Dove-tail Interlocking Feature on 1MS101
- Two-piece Modular Design
- UL Recognized File No. IZLT2.E35113
- CE
- 1000 Volt DC
- RoHS Compliant



Catalog #	Maximum Amperage	Wire Range	Tested At:	
			I ² t	I _p
1MS101	100	2/0 - #14	193 kA	27.4 kA
1MS102	400	(2) 250 kcmil - #6	3480 kA	69.5 kA
1MS103	400	(2) 250 kcmil - #6	3480 kA	69.5 kA
1MS104	600	(2) 500 kcmil - #6	2840 kA	50.8 kA

NOTE: Order two blocks per fuse

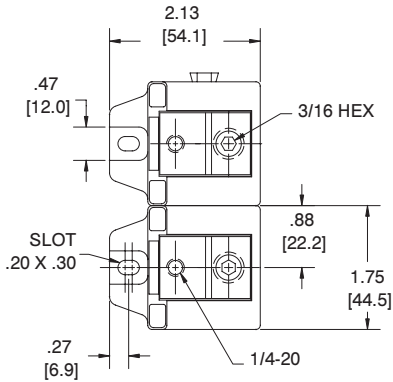

1MS101

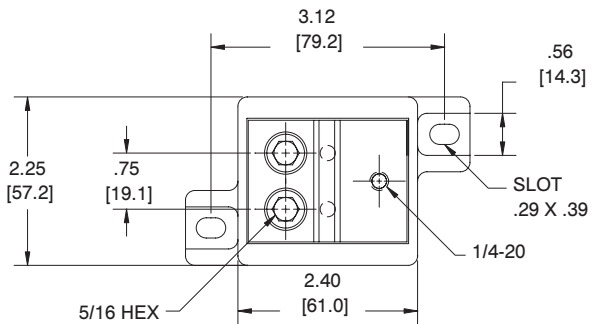

1MS102

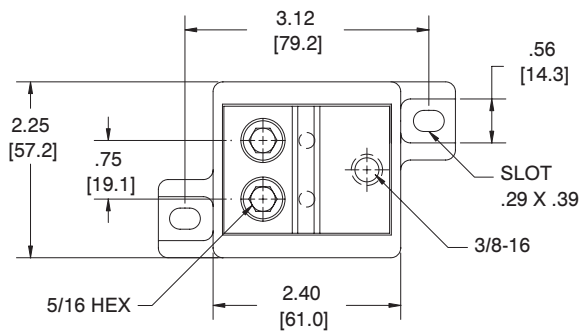

1MS103

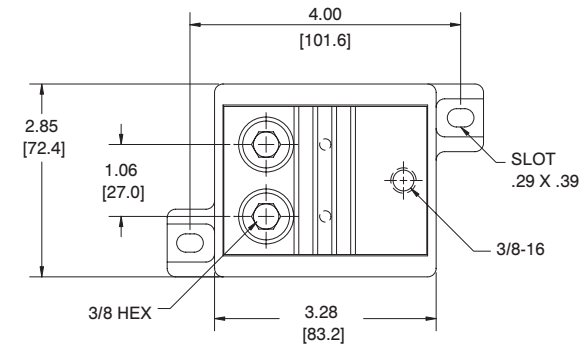

1MS104

Marathon Special Products fuse holders will comply to new harmonized fuse holder standard 4248. Please refer to www.marathonsp.com for the latest updates.

For electronic drawings or 2D/3D CAD data, send request to drawings@marathonsp.com

Semi Conductor Fuse Holders

1000 Volt⁺

Stud Version - Specifications:

- Tested and Approved for 200,000 Amp, 600 Volt Withstand Rating and Short Circuit Current Ratings (SCCR)
- Base, General Purpose Phenolic, 150°C
- Contact Customer Service for availability of thermoplastic version
- Stud, Steel Zinc Plated
- Nuts and Washers Provided Unassembled
- UL Recognized File No. IZLT2.E35113
- **CE**
- RoHS Compliant

+ Refer to www.marathonsp.com/PDFs/1000VCERating.pdf for details on availability of CE voltage ratings greater than 600 Volts

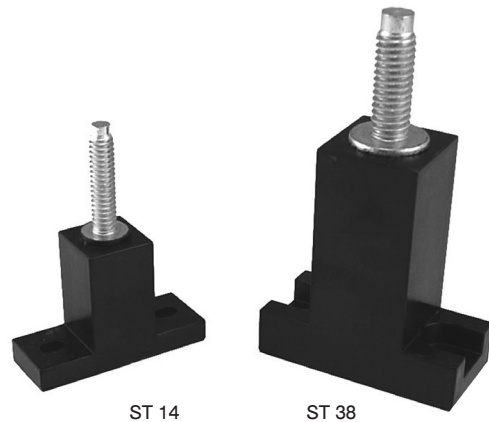

Catalog #	Maximum Amperage	Fuse Size	Tested At:	
			I ² t	I _p
ST 14	400	1" DIA	1130 kA	27.6 kA
ST 38	800	3" DIA	1130 kA	40.1 kA

Approved for 1,000 Volts - not interrupt tested

NOTE: Order two blocks per fuse

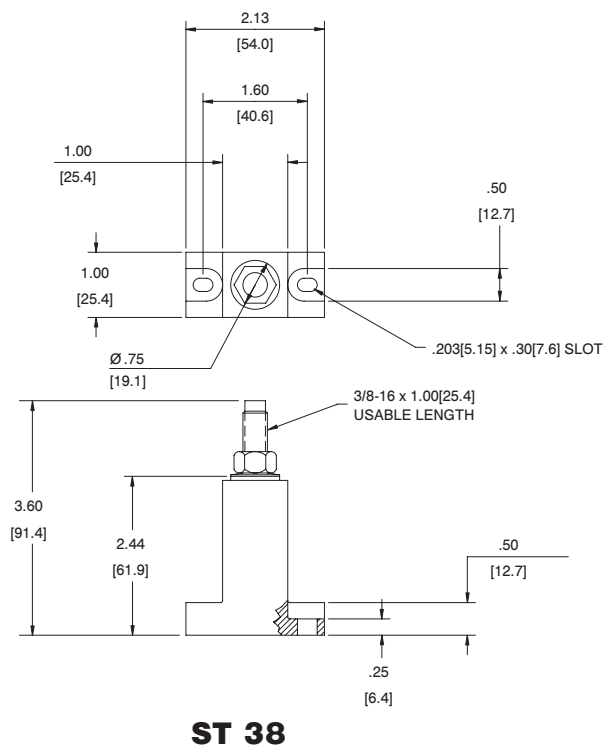
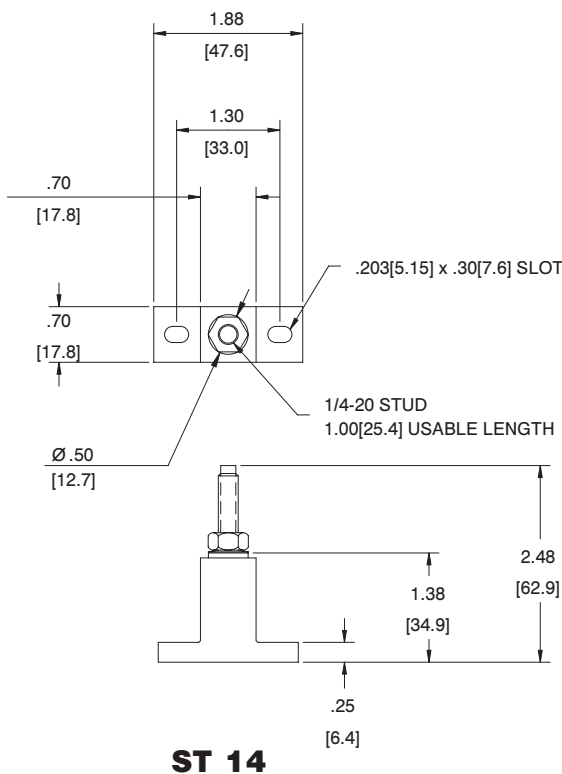

Marathon Special Products fuse holders will comply to new harmonized fuse holder standard 4248. Please refer to www.marathonsp.com for the latest updates.

For electronic drawings or 2D/3D CAD data, send request to drawings@marathonsp.com

Fuse Holders with BD (Box Distribution) Connectors

30 and 60 Amp 250 and 600 Volt

Specifications:

- Available on Class H, R and J Fuse Holders
- Connectors, High Conductive Aluminum, Tin Plated
- Reinforcing Member Available, Standard on Class R
- UL Recognized File No. IZLT2.E35113
- CSA Certified File No. LR21455
- RoHS Compliant

Class H and R Fuse Holders *Replace "X" with # of poles*

Catalog #	Volts	Amps	Line Wire Range	Load Wire Range
F60AXBD	250	60	(1) #2 - #10 AWG	(1) #2 - #10 AWG
R60AXBD				(1) #6 - #14 AWG
F60AXBD-D				
R60AXBD-D				
6F30AXBD-D	600	30	(1) #6 - #14 AWG	(1) #6 - #14 AWG
6R30AXBD-D				(2) #10 - #18 AWG
6F60AXBD		60	(1) #2 - #10 AWG	(1) #2 - #10 AWG
6R60AXBD				(1) #6 - #14 AWG
6F60AXBD-D			(1) #2 - #10 AWG	
6R60AXBD-D			(2) #6 - #14 AWG	



F60A3BD



6F30A3BDD

Class J Fuse Holders *Replace "X" with # of poles*

Catalog #	Volts	Amps	Line Wire Range	Load Wire Range
6J60AXBD	600	60	(1) #2 - #10 AWG	(1) #2 - #10 AWG
6J60AXBD-D				(1) #6 - #14 AWG
				(1) #2 - #10 AWG
				(2) #6 - #14 AWG

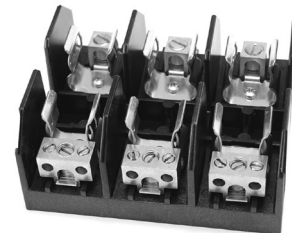

6J60A3BDD

Classes R and J - No Agency

Marathon Special Products fuse holders will comply to new harmonized fuse holder standard 4248. Please refer to www.marathonsp.com for the latest updates.

STSF Forklift/Semi Conductor Fuse Holder

Stud Version - Specifications:

- Base, High Strength Thermoplastic
- Temperature Rating of 170°C
- Studs, Stainless Steel (Nuts and Washers Provided)
- 130 Volt AC/DC, 1 to 400 Amps
- UL Recognized File No. IZLT2.E35113
- RoHS Compliant



ST SF

Applications:

This holder is used in direct current (DC) applications: forklifts, golf carts, electric vehicles, custom high-end car stereo systems, heavy equipment, marine aircraft, and similar applications.

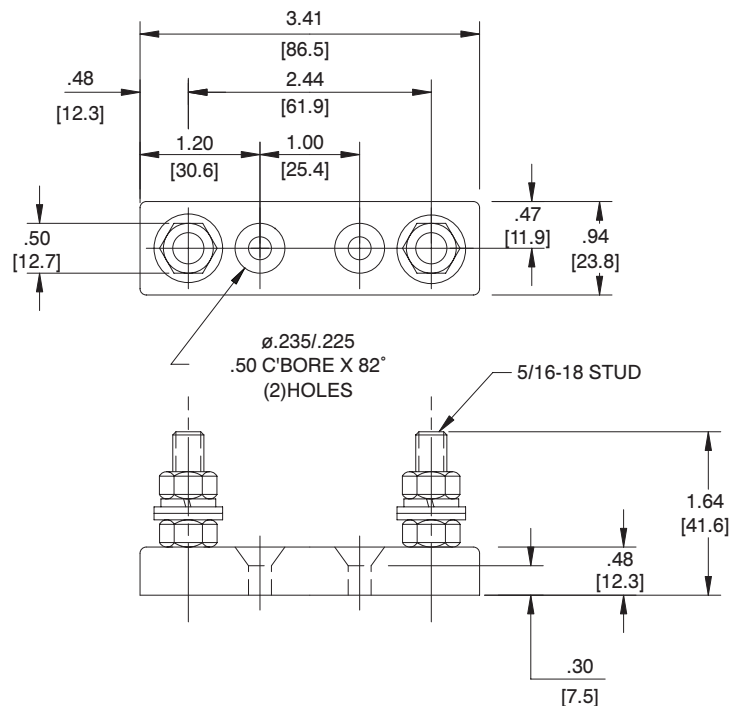

A #10 flat or conventional pan head screw head is acceptable.

For electronic drawings or 2D/3D CAD data, send request to drawings@marathonsp.com

Marathon Special Products fuse holders will comply to new harmonized fuse holder standard 4248. Please refer to www.marathonsp.com for the latest updates.

Fuse Holder Covers

Specifications:

- Material, Thermoplastic
- Thermal Rating, 125°C (RTI, per UL 746)
- Flammability, VO (per UL 94)
- UL Listed Accessories under File No. JDVS2.E181825
- In Application, Protection is Consistent with IEC Standard 529, Designation IP20 (Finger Safe)* - except CJ6100-1, CJ6100-2, and CJ6100-3
- Opening Allows View of Self-Indicating Fuses
- Holes for Test Probes and Re-tightening of Wire Terminations
- Covers fit most Fuse Holder Brands
- RoHS Compliant



Fuse Holder shown with Covers Attached

Catalog #	For use w/Fuse Holder #	Fuse Type	Voltage	Amp
CHR230	F30A/R30A	H/R	250	30
CHR260	F60A/R60A	H/R	250	60
CHR2100	RF100A/R100A	H/R	250	100
CHR630	6F30A/6R30A	H/R	600	30
CHR660	6F60A/6R60A	H/R	600	60
CHR6100	R6F100A/6R100A	H/R	600	100
CJ630	6J30A	J	600	30
CJ660	6J60A	J	600	60
CC630	6CC30A, Class G	CC, G	600	30
CC660	R6CC60A	CD	600	60
CCM630**	6M30A/6CCM30A	MISC	600	30
CJ6100-1C	6J100A	J	600	100
CJ6100-2C	6J100A	J	600	100
CJ6100-3C	6J100A	J	600	100

See page 33 for dimensional information

*Applications involving fuse holders other than Marathon may not provide IP20 finger protection

**Covers are recognized if used with recognized fuses

Cover/Puller (Catalog # CVR-MCC)

Marathon's Cover/Puller was designed for use with the Class CC (30 Amp), Midget and Class G (15 & 20 Amp only) Fuse Holders. Once installed, the Cover/Puller provides an easy and safe way to remove fuses. In application, protection is consistent with IEC Standard 529, designation IP20 (finger safe).

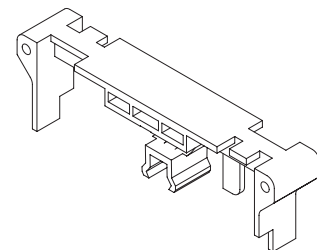
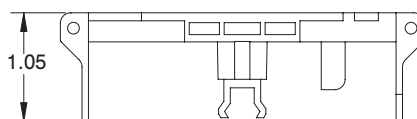
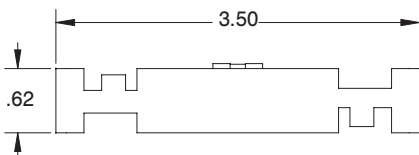
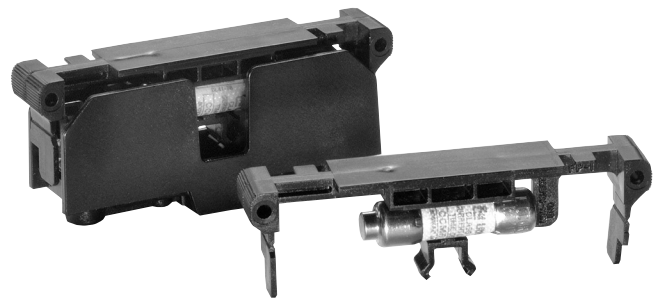

Marathon Special Products fuse holders will comply to new harmonized fuse holder standard 4248. Please refer to www.marathonsp.com for the latest updates.

For electronic drawings or 2D/3D CAD data, send request to drawings@marathonsp.com

Fuse Holder Covers

Catalog #	Figure	A	B	C	D	E	F
CHR230	FIG 1	3.76	1.67	0.86	2.54	0.40	0.30
CHR260	FIG 1	5.80	2.16	1.07	3.66	0.47	0.42
CHR2100	FIG 2	7.38	2.41	1.49	4.90	0.38	0.46
CHR630	FIG 1	7.56	1.71	1.10	5.58	0.47	0.42
CHR660	FIG 1	8.30	2.37	1.35	6.32	0.35	0.42
CHR6100	FIG 2	9.34	2.45	1.49	6.90	0.38	0.46
CJ630	FIG 1	4.30	1.95	0.90	2.66	0.35	0.30
CJ660	FIG 1	5.04	2.07	1.35	3.10	0.35	0.42
CC630	FIG 3	3.83	1.69	0.74	2.34	0.34	0.30
CC660	FIG 1	4.58	1.95	0.90	2.66	0.35	0.42
CCM630	FIG 3	3.83	1.69	0.74	2.34	0.34	0.30
CJ6100-1C	FIG 4	1.94	1.38				
CJ6100-2C	FIG 4	3.94	3.38				
CJ6100-3C	FIG 4	5.22	4.66				

(2 mounting screws supplied)

(2 mounting screws supplied)

(4 mounting screws supplied)

mm = dim X 25.4

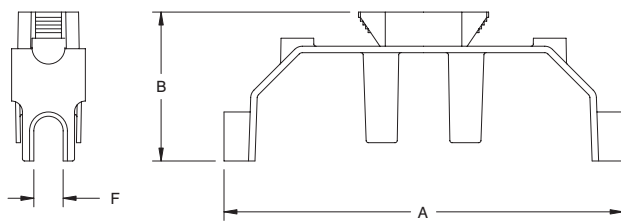
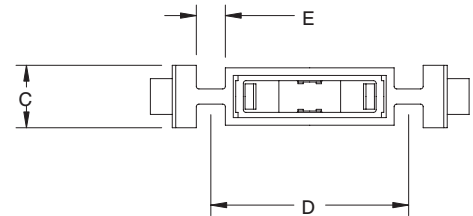
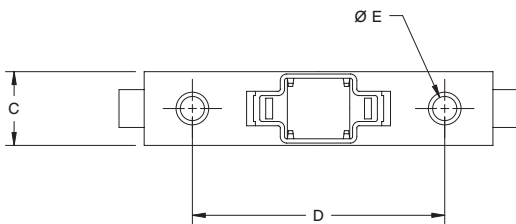

FIGURE 1:

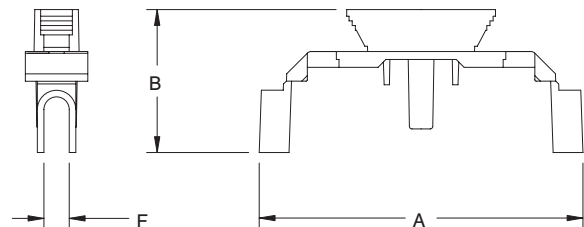

FIGURE 2:

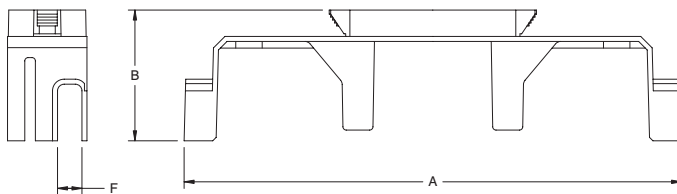
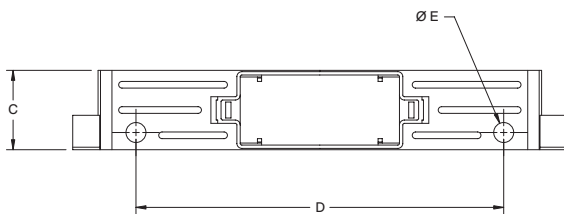

FIGURE 3:

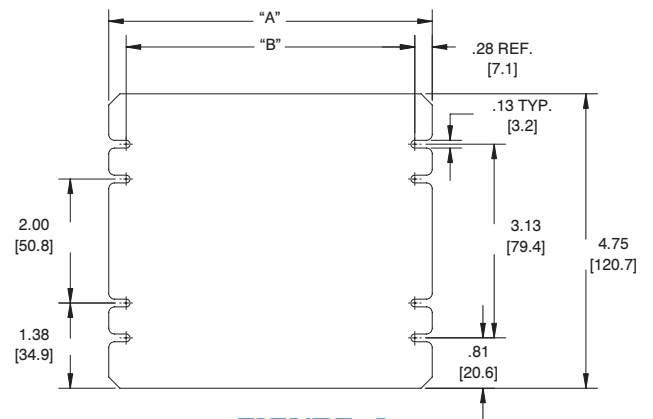

FIGURE 4:

Marathon Special Products fuse holders will comply to new harmonized fuse holder standard 4248. Please refer to www.marathonsp.com for the latest updates.

For electronic drawings or 2D/3D CAD data, send request to drawings@marathonsp.com

DIN Rail Adapters

DIN R 1:

- Accessory to Secure Surface Mount Devices on DIN Rail
- Made of Acetal Resin Material
- High Mechanical Strength and Rigidity
- Good Resilience and Resistance to Creep
- Excellent Dimensional Stability
- Excellent Low Temperature Toughness
- Wide End-Use Temperature Range
- Will Work with 2 and 3 pole Class H (250 Volt, 30 Amp) and Class R Fuse Holders (250 Volt, 30 Amp), and 985, 1100, 1200, 1500, 1600 and 1700 Series Heavy Duty Terminal Blocks
- RoHS Compliant

Assembly Method:

- Press Adapter onto Rail, Fasten Component with #8 Self Tapping Screw (Screw not Supplied)
- Assembly Locks Firmly unto DIN Rail

Catalog #	Std Pack Qty
DIN R 1	10



USE A #8 SELF TAPPING SCREW FOR MOUNTING COMPONENT



DIN R 2:

- For use with Class CC (30 Amp), Midget, and Class G Fuse Holders.
- RoHS Compliant

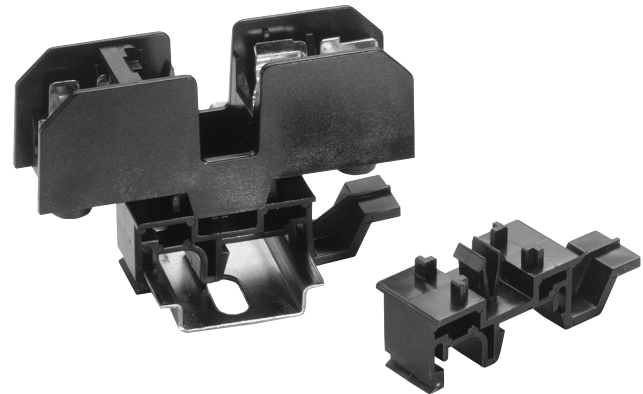
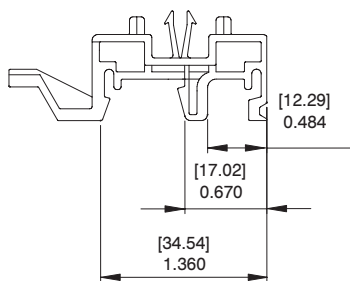
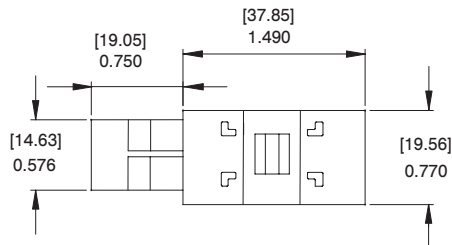

Assembly Method:

- DIN R 2 snaps securely to the Marathon Fuse Holders and to DIN Rails without Tools, which Permits the Fuse Holders to be Mounted Directly to Standard and Low Profile 35mm Symmetrical and 32mm Asymmetrical DIN Rails.
- May be Removed by Lifting the Disconnect Tab

Catalog #	Std Pack Qty
DIN R 2	10

Marathon Special Products fuse holders will comply to new harmonized fuse holder standard 4248. Please refer to www.marathonsp.com for the latest updates.

For electronic drawings or 2D/3D CAD data, send request to drawings@marathonsp.com

Power Distribution Blocks with Short-Circuit Current Ratings

General Information:

The requirements of the 2005 National Electric Code (NEC) and UL508A now require many electrical panels to carry a Short Circuit Current Rating (SCCR). Analyzing the SCCR of individual components and overcurrent protection devices is a method of determining the SCCR of an electrical assembly. Equipment with low SCCR's are limited to locations where only low-level short-circuit current is available. By replacing a low-rated power distribution block with a Marathon high SCCR power distribution block, an assembly can achieve a higher SCCR for more installation flexibility.



Marathon's Power Distribution Blocks are standard products that have been used in electrical control panels for over 35 years. These blocks have now been tested and approved for higher SCCR. **The higher ratings are based on proper wire sizes and the appropriate circuit protection device (fuses or circuit breakers).** UL508A does allow default SCCR for Power Distribution Blocks of 10,000A with no additional testing.

Marathon's Power Distribution Blocks are recognized under UL Standard 1059 (UL File # E62806) and have been investigated by UL for Short Circuit Current Rating under category XCFR2; Terminal Blocks-Component.

In addition, Marathon offers Power Distribution Blocks that are listed to UL 1953 (UL File # E309401). The feeder spacing requirements of UL508A are achieved with these blocks.

For detailed SCCR product information, please visit www.marathonsp.com/PDFs/SCCR.pdf

UL Listed Power Distribution Blocks

The requirements of the 2005 National Electric Code (NEC) and UL508A now require many electrical panels to carry a Short Circuit Current Rating (SCCR). These new Power Distribution Blocks are listed to UL1953. The feeder spacing requirements of UL508A are achieved with these blocks.

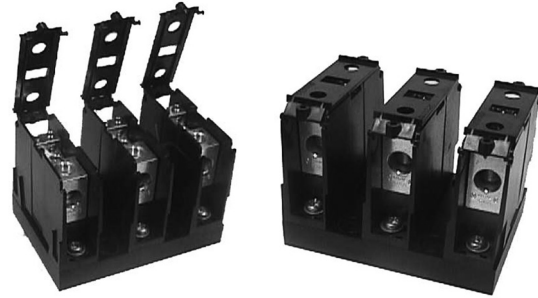

Specifications:

- Connector Housings, Thermoplastic, UL 94 V-0, RTI 125°C
- Insulator Base Plate, Phenolic Laminate, UL 94 V-0, RTI 130°C
- Wire Connectors - Tin Plated Aluminum, Rated for Copper or Aluminum Wire (CU & AL)
- Short Circuit Current Rating up to 100kA (100kA SCCR Rating with copper conductors only. Requires specific over-current protection device.)
- Flexible Stranded Wire Compliant
- Attached hinged cover
- UL 508A Feeder Circuit Terminal Spacing for up to 600 Volts
- Rated up to 335 Amp, 600 Volts
- Line side conductor up to 600 kcmil
- Distribution, up to twelve conductors per pole
- Investigated to UL 1953
- UL Category and File: QPQS.E309401
- RoHS Compliant
- **For detailed SCCR information with fuses and circuit breakers, please refer to datasheets on www.marathonsp.com**

Catalog #	Current Amps		Connector Material	LINE SIDE			LOAD SIDE			SCCR RMS Sym Amps 600 volt Max
	CU	AL		Wire Range AWG/kcmil	Openings Per Pole	Connector Config.	Wire Range AWG/kcmil	Openings Per Pole	Connector Config.	
FPB23570 CH	175	135	Aluminum	2/0 - #14	1		#4 - #14	4		100,000
FPB23572 CH	175	135	Aluminum	2/0 - #14	1		2/0 - #14	1		100,000
FPB23574 CH	175	135	Aluminum	2/0 - #14	1		1/4 - 20 stud	1		100,000
FPB23580 CH	175	135	Aluminum	2/0 - #14	1		#4 - #14	6		100,000
FPB33553 CH	335	270	Aluminum	400 kcmil - #6	1		#2 - #14	6		100,000
FPB33588 CH	335	335	Aluminum	600 kcmil - #2	1		1/0 - #14	3		100,000
							#2 - #14	6		
FPB33595 CH	335	335	Aluminum	600 kcmil - #2	1		#4 - #14	12		100,000

See page 37 for dimensional information.

UL Listed Power Distribution Blocks

UL Listed Power Blocks

FPB23XXX

PRODUCT & SCCR INFORMATION PROVIDED ON SIDES OF BLOCK

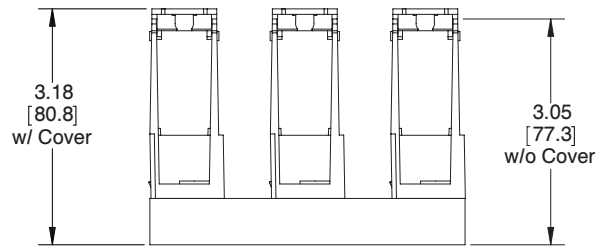
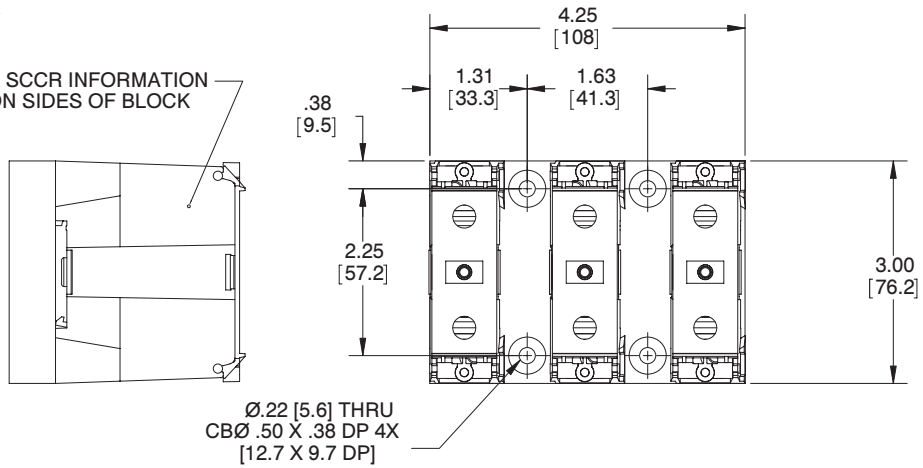

FPB33XXX

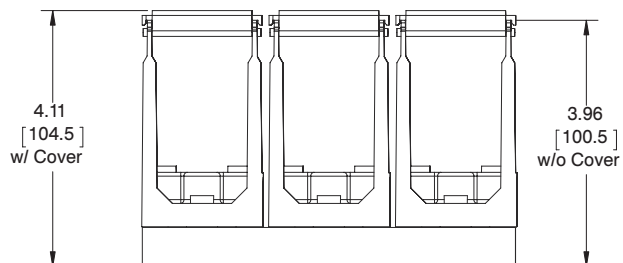
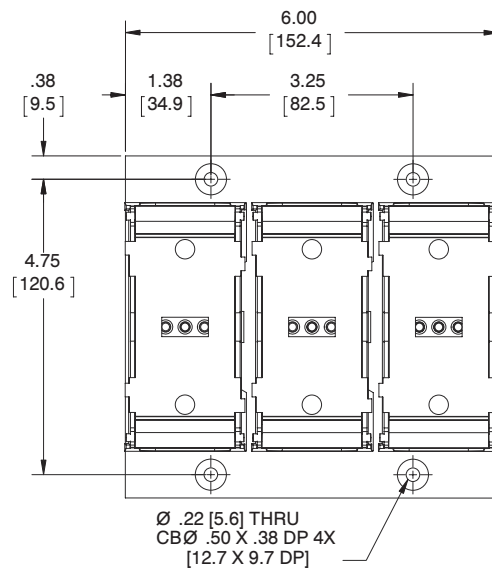
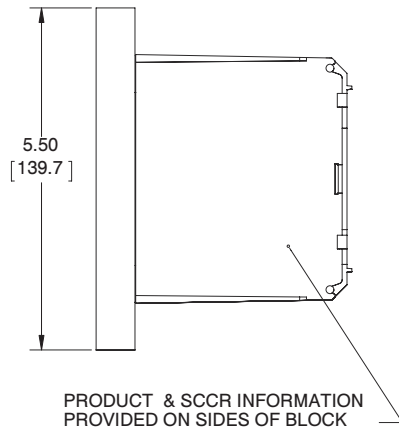

For electronic drawings or 2D/3D CAD data, send request to drawings@marathonsp.com

Datasheets available at marathonsp.com

UL Listed Enclosed Power Blocks

Specifications:

Electrical

- 600 Volts AC/DC*
- 1000 Volts (IEC)
- Up to 115 Amps
- Wire Range #2 to #14
- Flexible Stranded Wire Compliant

Mechanical

- Base, Gray Thermoplastic, 125°C (257°F) (UL RTI)
- Flammability, UL 94 V-0
- Mounting: DIN or panel mount

+ Refer to www.marathonsp.com/PDFs/1000VCERating.pdf for details on availability of CE voltage ratings greater than 600 Volts

Standards



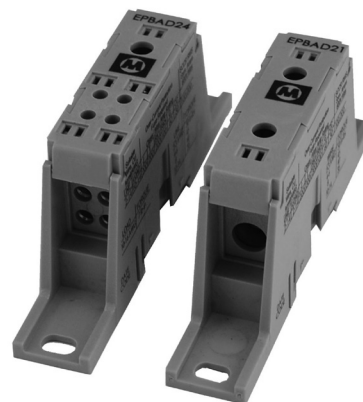

- UL Listed File No. QPQS.E309401 (UL 1953)
- CSA Certified File No. LR19766 (CSA C22-2 No. 158)
- **CE** (Component IEC 60947-7-1)
- IEC 60529, IP-20
- RoHS Compliant

Accessories (consult Cust. Service)

- White Markers to Identify Circuits
- DIN Rail for Mounting Option
- End Piece for DIN Rail (MSK35)



Shown left to right: EPBAD24, EPBAD21

Catalog #	Amperage CU Wire 75°C	LINE SIDE			LOAD SIDE			SCCR, RMS SYM Amps 600 Volt Max
		Wire Range AWG/kcmil	Openings Per Pole	Connector Configuration	Wire Range AWG/kcmil	Openings Per Pole	Connector Configuration	
EPBAD21	115	#2 - #14 AWG 35 - 2.5 mm ²	1		#2 - #14 AWG 35 - 2.5 mm ²	1		100,000
EPBAD24	115	#2 - #14 AWG 35 - 2.5 mm ²	1		#10 - #14 AWG 6 - 2.5 mm ²	4		65,000

Ordering Code:

EPB

A

D

21

Connector Material:
A - Aluminum rated copper or aluminum wire

D - Mount on 35 mm DIN rail or flat panel
21 - (1) #2 to (1) #2
24 - (1) #2 to (4) #10

Note:

- 1) The ampacities are based on Table 310-16 of the NEC.
- 2) The connectors were tested and approved per UL 486 A/B.
- 3) For detailed SCCR information with fuses and circuit breakers, please refer to datasheets on www.marathonsp.com

For electronic drawings or 2D/3D CAD data, send request to drawings@marathonsp.com

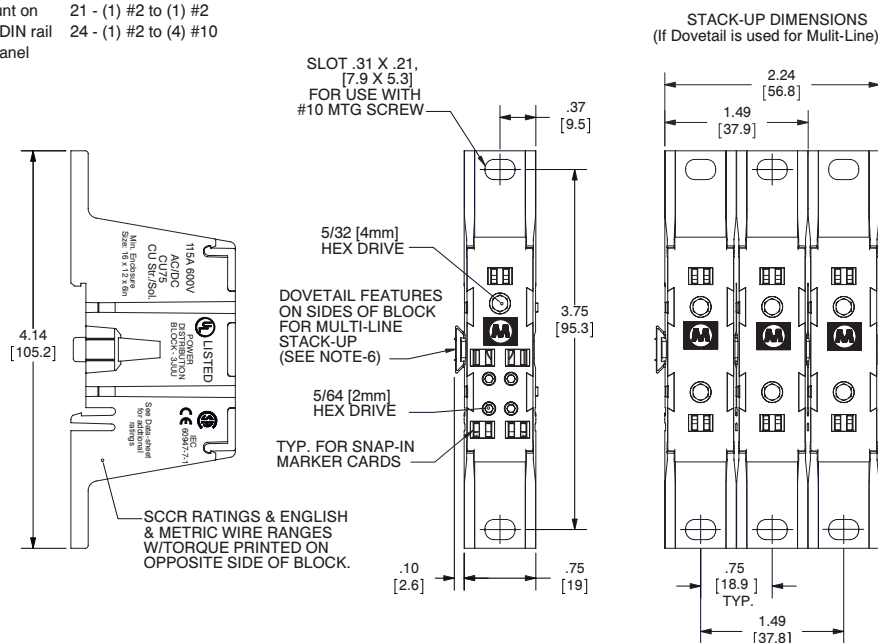

Enclosed Power Blocks

COMING SOON: UL LISTED ENCLOSED POWER BLOCKS

Specifications:

Electrical

- 600 Volts AC/DC*
(IEC - 690 Volts AC/DC)
- Up to 510 Amps
- Wire Range 2/0 to 400 kcmil
- Flexible Stranded Wire Compliant

Mechanical

- Base, Gray Thermoplastic, 125°C (UL RTI)
- Flammability, UL 94 V-0
- Mounting: DIN or panel mount

Standards

- UL Recognized File No. XCFR2.E62806 (UL 1059)
- CSA Certified File No. LR19766 (CSA C22.2 No. 158)
-  (IEC 60947-7-1)
- IEC 60529, IP-20
- RoHS Compliant

Accessories (consult Cust. Service)

- White Markers to Identify Circuits
- Black Thermoplastic Safety Plugs
- Feed Spacing UL508A Adapter Plate



Shown left to right: EPBAD71, EPBAD74
EPBAD41, EPBAD44

Multiple Wire Ratings





Copper Stranded Wire Only

#2 opening:	2/0 opening:
(2) #6 AWG	(2) #4 AWG
(2) #8 AWG	(2) #6 AWG
(2 to 4) #10 AWG	(2) #8 AWG
(2 to 4) #12 AWG	(2) #10 AWG
(2 to 4) #14 AWG	(2) #12 AWG
	(2) #14 AWG

Connector Wire Hole Size

Conductor opening:	Diameter of opening:
#2 - #14 AWG	.38"
2/0 - #14 AWG	.50"
250 kcmil - #6 AWG	.72"
400 kcmil - #6 AWG	.94"

+ Refer to www.marathonsp.com/PDFs/1000VCERating.pdf for details on availability of CE voltage ratings greater than 600 Volts

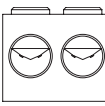
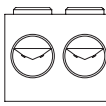
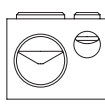
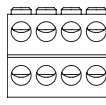
Catalog #	Amperage CU Wire 75°C	LINE SIDE			LOAD SIDE			SCCR, RMS SYM Amps 600 Volt Max
		Wire Range AWG/kcmil	Openings Per Pole	Connector Config.	Wire Range AWG/kcmil	Openings Per Pole	Connector Config.	
EPBXD41	175	2/0 - #14 AWG 70 - 2.5 mm ²	1		2/0 - #14 AWG 70 - 2.5 mm ²	1		100,000
EPBXD44	175	2/0 - #14 AWG 70 - 2.5 mm ²	1		#2 - #14 AWG 35 - 2.5 mm ²	4		100,000
EPBXD71	510	250 kcmil - #6 AWG 120 - 16 mm ²	2		250 kcmil - #6 AWG 120 - 16 mm ²	2		10,000
EPBXP71								50,000 - 100,000
EPBXD74	335	400 kcmil - #6 AWG 185 - 16 mm ² 2/0 - #14 AWG 70 - 2.5 mm ²	1		#2 - #14 35 - 2.5mm ²	8		10,000
EPBXP74			1					100,000

Ordering Code:

EPB

A

D

41

Connector Material:
A - Aluminum rated
copper or aluminum
wire

C - Copper rated copper
wire only

D - Mount on
35 mm DIN rail
or flat panel

P - Flat panel
(for 71 and 74
only)

41 - (1) 2/0 to (1) 2/0
44 - (1) 2/0 to (4) #2
71 - (2) 250 kcmil to
(2) 250 kcmil
74 - (1) 400 kcmil to
(1) 2/0 to (8) #2

Note:

- 1) The ampacities are based on Table 310-16 of the NEC.
- 2) For detailed SCCR information with fuses and circuit breakers, please refer to datasheets on www.marathonsp.com

See page 40 for dimensional information.

Enclosed Power Block Dimensions

EPBXD41 & EPBXD44

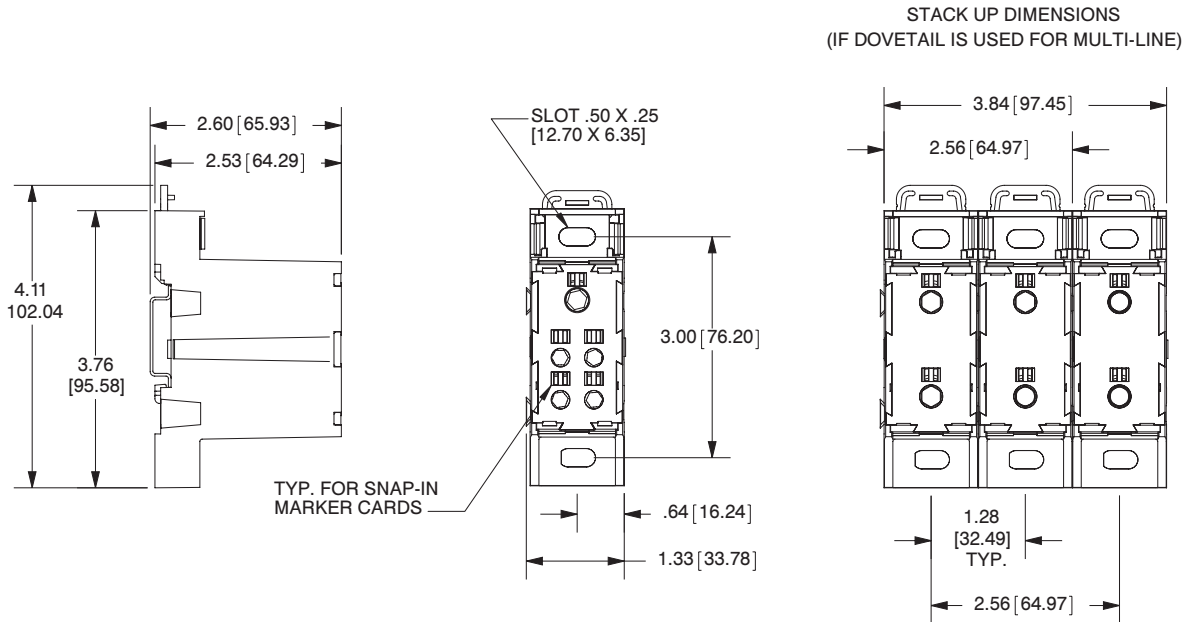

EPBXX71 & EPBXX74

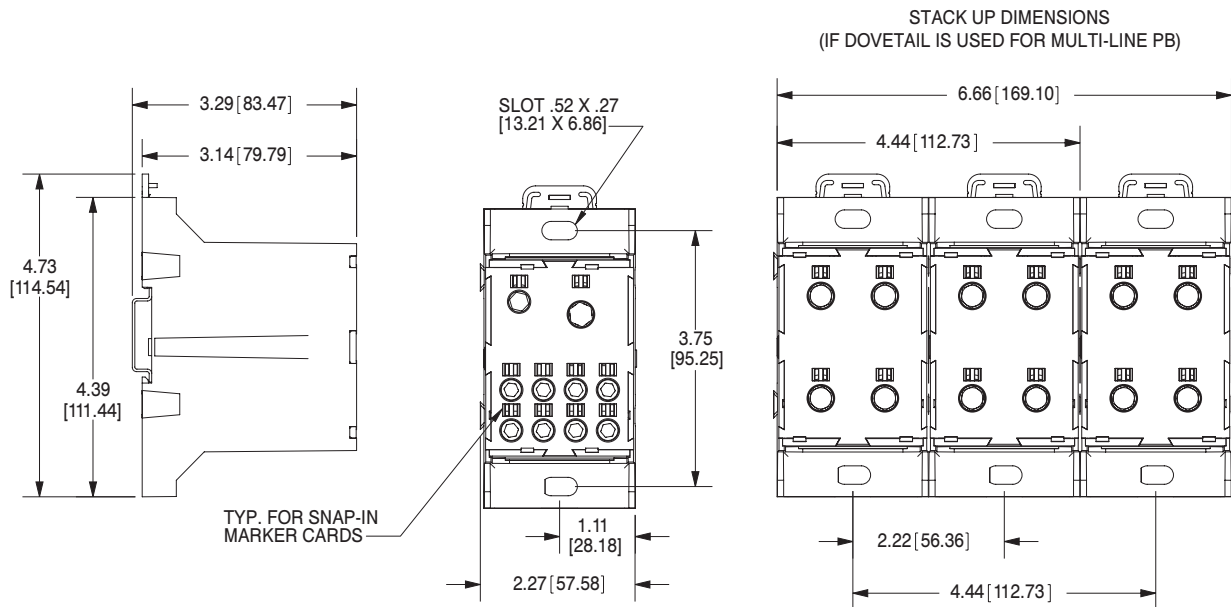

For electronic drawings or 2D/3D CAD data, send request to drawings@marathonsp.com

Power Terminal Blocks

General Information:

Barrier Style Power Terminal Blocks are available in eight sizes. They are identified by the first three digits of the catalog number. The 140, 142, 143, 144 and 145 series are manufactured with general purpose phenolic rated at 150°C. The 141, 132 and 133 series are manufactured with high impact thermoplastic rated at 125°C.

Enclosed touch proof power terminal blocks (EPB series) are available in three sizes (one listed, two recognized).

Connector Wire Hole Size:

Conductor Opening		Diameter of Opening	
English	Metric	Inch	Metric
#10 AWG	6	.158"	4.0
#4 AWG	25	.250"	6.4
#2 AWG	35	.352**	7.9
1/0	50	.406"	10.3
2/0	70	.438**	11.1
3/0	95	.532"	13.5
250 kcmil	120	.630**	16.0
350 kcmil	185	.718"	18.2
400 kcmil	-	.769**	-
500 kcmil	240	.875"	22.2
600 kcmil	300	.938"	23.8
750 kcmil	-	1.125"	-
1000 kcmil	-	1.250"	-

* Enclosed blocks have larger openings (see page 39)

Ratings and Standards:

The voltage ratings of terminal blocks are based upon the minimum spacing between electrically conductive parts line to line through air and over surface and line to ground through air and over surface.

Class A

Service equipment including deadfront switchboards, panel boards, service entrance devices.

Class B

Commercial appliances including business equipment, electronic data processing equipment and the like.

Class C

General industrial and machine tool controls which can be further defined as equipment falling under UL 508. Ratings based on UL 1059 may be higher in some cases depending on application.

Spacing Requirements*:

	Voltage	Thru Air	Over Surface
Class A	51-150	.500	.750
	151-300	.750	1.250
	301-600	1.000	2.000
Class B	51-150	.063	.063
	151-300	.094	.094
	301-600	.375	.500
Class C	51-150	.125	.250
	151-300	.250	.375
	301-600	.375	.500

*In Inches

Applications:

Designed for use with solar, wind, alternate energy, transportation, heating, air conditioning and refrigeration, elevator systems, material handling equipment, control panels, motor control, switchgear and any area where power needs to be distributed to more than one load.

Power Distribution Blocks

600 Volts AC/DC Up to 1000 Volts AC/DC (CE)⁺

Specifications:

- Connector, High Conductive Aluminum, Tin Plated, Rated for Copper and Aluminum Wire
- CU Connector, High Conductive Copper, Tin Plated, Rated for Copper Wire Only
- Amp Rating Based on NEC Table 310-16 Using 75°C Copper Wire
- UL Recognized File No. XCFR2.E62806
- CSA Certified File No. LR19766
- **CE**
- Flexible Stranded Wire Compliant
- RoHS Compliant
- **For detailed SCCR information with fuses and circuit breakers, please refer to datasheets on www.marathonsp.com**

+ Refer to www.marathonsp.com/PDFs/1000VCERating.pdf for details on availability of CE voltage ratings greater than 600 Volts



1423570



1414400

** Openings rated for #4-14 AWG are multiple wire rated:
(2) #10 CU Str, (2 to 4) #12 CU Str, and (2 to 4) #14 CU Str.

*** Openings rated for #2-14 AWG are multiple wire rated:
(2) #8 CU Str, (2) #10 CU Str, (2) #12 CU Str, and (2) #14 CU Str.

Replace "X" with # of poles (0 = Adder)

Catalog #	Hinge Cover	Poles (X)	Amps	MATERIAL		LINE SIDE			LOAD SIDE		
				Insulator	Conn.	Wire Range AWG/kcmil	Openings Per Pole	Connector Configuration	Wire Range AWG/kcmil	Openings Per Pole	Connector Configuration
141X403		1/2/3/4	60	Plastic	AL	#2 - #14 AWG	1		#10 - #16 AWG	2	
141X400		1/2/3/4	115	Plastic	AL	#2 - #14 AWG	1		#10 - #16 AWG	4	
132X570	CH	0/1/2/3	175	Plastic	AL	2/0 - #14 AWG	1		#4 - #14 AWG**	4	
142X570		1/2/3	175	Phenolic	AL	2/0 - #14 AWG	1		#4 - #14 AWG**	4	
132X580	CH	0/1/2/3	175	Plastic	AL	2/0 - #14 AWG	1		#4 - #14 AWG**	6	
140X402		2/3	175	Phenolic	AL	2/0 - #14 AWG	1		#4 - #14 AWG**	4	
140X401		2/3	175	Phenolic	AL	2/0 - #14 AWG	1		#4 - #14 AWG**	6	
132X970	CH	0/1/2/3	175	Plastic	CU	2/0 - #14 AWG	1		#4 - #14 AWG**	4	
142X970		1/2/3	175	Phenolic	CU	2/0 - #14 AWG	1		#4 - #14 AWG**	4	
140X404		2/3	310	Phenolic	AL	350 kcmil - #6 AWG	1		#4 - #14 AWG	6	
133X554	CH	1/2/3	310	Plastic	AL	350 kcmil - #6 AWG	1		2/0 - #14 AWG	2	

CH = Block is also available with hinge cover attached - include "CH" at end of part number when ordering (not available on Adder blocks) - See page 55 for available covers

See pages 52-54 for dimensional information

Power Distribution Blocks (cont.)

600 Volts AC/DC Up to 1000 Volts AC/DC (CE)⁺

Specifications:

- Connector, High Conductive Aluminum, Tin Plated, Rated for Copper and Aluminum Wire
- CU Connector, High Conductive Copper, Tin Plated, Rated for Copper Wire Only
- Amp Rating Based on NEC Table 310-16 Using 75°C Copper Wire
- UL Recognized File No. XCFR2.E62806
- CSA Certified File No. LR19766
- CE
- Flexible Stranded Wire Compliant
- RoHS Compliant
- **For detailed SCCR information with fuses and circuit breakers, please refer to datasheets on www.marathonsp.com**

+ Refer to www.marathonsp.com/PDFs/1000VCERating.pdf for details on availability of CE voltage ratings greater than 600 Volts

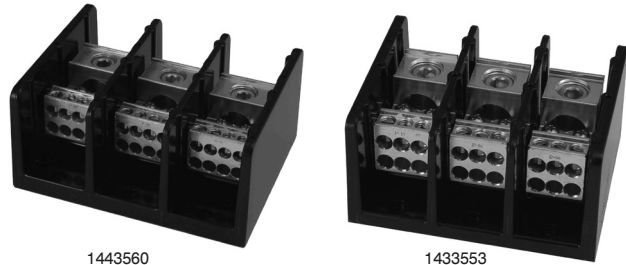

** Openings rated for #4-14 AWG are multiple wire rated:
(2) #10 CU Str, (2 to 4) #12 CU Str, and (2 to 4) #14 CU Str.

*** Openings rated for #2-14 AWG are multiple wire rated:
(2) #8 CU Str, (2) #10 CU Str, (2) #12 CU Str, and (2) #14 CU Str.

Replace "X" with # of poles

Catalog #	Hinge Cover	Poles (X)	Amps	MATERIAL		LINE SIDE			LOAD SIDE		
				Insulator	Conn.	Wire Range AWG/kcmil	Openings Per Pole	Connector Configuration	Wire Range AWG/kcmil	Openings Per Pole	Connector Configuration
144X401		1/2/3	335	Phenolic	AL	400 kcmil - #6 AWG	1		#2 - #14 AWG	6	
143X552		1/2/3	335	Phenolic	AL	400 kcmil - #6 AWG	1		#2 - #14 AWG	4	
143X553		1/2/3	335	Phenolic	AL	400 kcmil - #6 AWG	1		#2 - #14 AWG	6	
144X560		1/2/3	335	Phenolic	AL	400 kcmil - #6 AWG	1		#2 - #14 AWG	8	
133X552	CH	1/2/3	335	Plastic	AL	400 kcmil - #6 AWG	1		#2 - #14 AWG***	4	
143X555		1/2/3	350	Phenolic	AL	2/0 - #14 AWG	2		#4 - #14 AWG**	6	
133X555	CH	1/2/3	350	Plastic	AL	2/0 - #14 AWG	2		#4 - #14 AWG**	6	
143X955		1/2/3	350	Phenolic	CU	2/0 - #14 AWG	2		#4 - #14 AWG**	6	
133X955	CH	1/2/3	350	Plastic	CU	2/0 - #14 AWG	2		#4 - #14 AWG**	6	
143X953		1/2/3	380	Phenolic	CU	500 kcmil - #4 AWG	1		#2 - #14 AWG	6	
133X953	CH	1/2/3	380	Plastic	CU	500 kcmil - #4 AWG	1		#2 - #14 AWG***	6	

CH = Block is also available with hinge cover attached - include "CH" at end of part number when ordering (not available on Adder blocks) - See page 55 for available covers

See pages 52-54 for dimensional information

Power Distribution Blocks (cont.)

600 Volts AC/DC Up to 1000 Volts AC/DC (CE)⁺

Specifications:

- Connector, High Conductive Aluminum, Tin Plated, Rated for Copper and Aluminum Wire
- CU Connector, High Conductive Copper, Tin Plated, Rated for Copper Wire Only
- Amp Rating Based on NEC Table 310-16 Using 75°C Copper Wire
- UL Recognized File No. XCFR2.E62806
- CSA Certified File No. LR19766
- CE
- Flexible Stranded Wire Compliant
- RoHS Compliant
- For detailed SCCR information with fuses and circuit breakers, please refer to datasheets on www.marathonsp.com

+ Refer to www.marathonsp.com/PDFs/1000VCERating.pdf for details on availability of CE voltage ratings greater than 600 Volts



1333588 CH

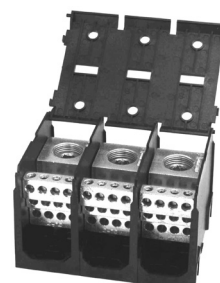

1333595 CH

** Openings rated for #4-14 AWG are multiple wire rated:
(2) #10 CU Str, (2 to 4) #12 CU Str, and (2 to 4) #14 CU Str.

*** Openings rated for #2-14 AWG are multiple wire rated:
(2) #8 CU Str, (2) #10 CU Str, (2) #12 CU Str, and (2) #14 CU Str.

Replace "X" with # of poles

Catalog #	Hinge Cover	Poles (X)	Amps	MATERIAL		LINE SIDE			LOAD SIDE		
				Insulator	Conn.	Wire Range AWG/kcmil	Openings Per Pole	Connector Configuration	Wire Range AWG/kcmil	Openings Per Pole	Connector Configuration
144X551		1/2/3	380	Phenolic	AL	500 kcmil - #4 AWG	1		#2 - #14 AWG	6	
145X579		1/2/3	380	Phenolic	AL	500 kcmil - #4 AWG	1		2/0 - #14 AWG	6	
133X587	CH	1/2/3	380	Plastic	AL	500 kcmil - #4 AWG	1		#2 - #14 AWG*** 350 kcmil - #6 AWG	3 1	
143X587		1/2/3	380	Phenolic	AL	500 kcmil - #4 AWG	1		#2 - #14 AWG*** 350 kcmil - #6 AWG	3 1	
145X594		1/2/3	380	Phenolic	AL	500 kcmil - #4 AWG	1		#2 - #14 AWG	8	
145X552		1/2/3	380	Phenolic	AL	500 kcmil - #4 AWG	1		#2 - #14 AWG	12	
133X588	CH	1/2/3	420	Plastic	AL	600 kcmil - #2 AWG	1		#2 - #14 AWG*** 1/0 - #14 AWG	6 3	
133X595	CH	1/2/3	420	Plastic	AL	600 kcmil - #2 AWG	1		4 - #14 AWG**	12	
133X585	CH	1/2/3	420	Plastic	AL	600 kcmil - #2 AWG	1		2 - #14 AWG***	8	
133X575	CH	1/2/3	420	Plastic	AL	600 kcmil - #2 AWG	1		2/0 - #14 AWG	4	
133X565	CH	1/2/3	420	Plastic	AL	600 kcmil - #2 AWG	1		250 kcmil - #6 AWG	2	

CH = Block is also available with hinge cover attached - include "CH" at end of part number when ordering - See page 55 for available covers

See pages 52-54 for dimensional information

Power Distribution Blocks (cont.)

600 Volts AC/DC Up to 1000 Volts AC/DC (CE)⁺

Specifications:

- Connector, High Conductive Aluminum, Tin Plated, Rated for Copper and Aluminum Wire
- CU Connector, High Conductive Copper, Tin Plated, Rated for Copper Wire Only
- Amp Rating Based on NEC Table 310-16 Using 75°C Copper Wire
- UL Recognized File No. XCFR2.E62806
- CSA Certified File No. LR19766
- CE
- Flexible Stranded Wire Compliant
- RoHS Compliant
- **For detailed SCCR information with fuses and circuit breakers, please refer to datasheets on www.marathonsp.com**

+ Refer to www.marathonsp.com/PDFs/1000VCERating.pdf for details on availability of CE voltage ratings greater than 600 Volts

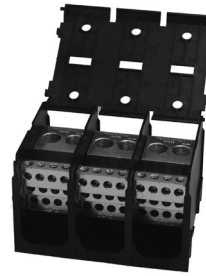

1333596 CH



1333598 CH

** Openings rated for #4-14 AWG are multiple wire rated:
(2) #10 CU Str, (2 to 4) #12 CU Str, and (2 to 4) #14 CU Str.

*** Openings rated for #2-14 AWG are multiple wire rated:
(2) #8 CU Str, (2) #10 CU Str, (2) #12 CU Str, and (2) #14 CU Str.

Replace "X" with # of poles

Catalog #	Hinge Cover	Poles (X)	Amps	MATERIAL		LINE SIDE			LOAD SIDE		
				Insulator	Conn.	Wire Range AWG/kcmil	Openings Per Pole	Connector Configuration	Wire Range AWG/kcmil	Openings Per Pole	Connector Configuration
133X596	CH	1/2/3	510	Plastic	AL	250 kcmil - 1/0 AWG	2		#4 - #14 AWG**	12	
133X597	CH	1/2/3	510	Plastic	AL	250 kcmil - 1/0 AWG	2		#2 - #14 AWG***	8	
133X598	CH	1/2/3	510	Plastic	AL	250 kcmil - 1/0 AWG	2		2/0 - #14 AWG	4	
145X587		1/2/3	690	Phenolic	AL	500 kcmil - #4 AWG 350 kcmil - #4 AWG	1 1		2/0 - #14 AWG	4	
145X592		1/2/3	760	Phenolic	AL	500 kcmil - #4 AWG	2		#4 - #14 AWG**	12	
145X586		1/2/3	760	Phenolic	AL	500 kcmil - #6 AWG	2		2/0 - #14 AWG	8	
145X992		1/2/3	760	Phenolic	CU	500 kcmil - #4 AWG	2		#2 - #14 AWG	12	
145X986		1/2/3	760	Phenolic	CU	500 kcmil - #4 AWG	2		2/0 - #14 AWG	8	
145X408		1/2/3	760	Phenolic	AL	500 kcmil - #6 AWG	2		#2 - #14 AWG	12	
145X411		1/2/3	840	Phenolic	AL	600 kcmil - #2 AWG	2		3/0 - #6 AWG #4 - #14 AWG**	4 4	
1453401*		1	2280	Phenolic	AL	500 kcmil - #4 AWG	6		2/0 - #14 AWG	18	

CH = Block is also available with hinge cover attached - include "CH" at end of part number when ordering - See page 55 for available covers

See pages 52-54 for dimensional information

*Special one-pole block. Apply Power Block Dimensions for 145 Series block on page 54 (3 pole).

Power Splicer Blocks

600 Volts AC/DC Up to 1000 Volts AC/DC (CE)⁺

Specifications:

- Connector, High Conductive Aluminum, Tin Plated, Rated for Copper and Aluminum Wire
- CU Connector, High Conductive Copper, Tin Plated, Rated for Copper Wire Only
- Amp Rating Based on NEC Table 310-16 Using 75°C Copper Wire
- UL Recognized File No. XCFR2.E62806
- CSA Certified File No. LR19766
- CE
- Flexible Stranded Wire Compliant
- RoHS Compliant
- For detailed SCCR information with fuses and circuit breakers, please refer to datasheets on www.marathonsp.com

+ Refer to www.marathonsp.com/PDFs/1000VCERating.pdf for details on availability of CE voltage ratings greater than 600 Volts

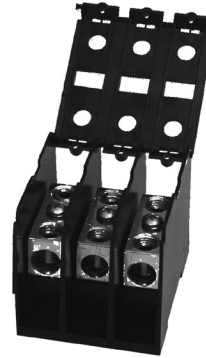

1323972 CH



1323572 CH

Replace "X" with # of poles (0 = Adder)

Catalog #	Hinge Cover	Poles (X)	Amps	MATERIAL		LINE SIDE			LOAD SIDE		
				Insulator	Conn.	Wire Range AWG/kcmil	Openings Per Pole	Connector Configuration	Wire Range AWG/kcmil	Openings Per Pole	Connector Configuration
141X300		1/2/3/4	115	Plastic	AL	#2 - #14 AWG	1		#2 - #14 AWG	1	
142X552		1/2/3	115	Phenolic	AL	#2 - #14 AWG	1		#2 - #14 AWG	1	
132X572	CH	0/1/2/3	175	Plastic	AL	2/0 - #14 AWG	1		2/0 - #14 AWG	1	
142X572		1/2/3	175	Phenolic	AL	2/0 - #14 AWG	1		2/0 - #14 AWG	1	
132X972	CH	0/1/2/3	175	Plastic	CU	2/0 - #14 AWG	1		2/0 - #14 AWG	1	
142X121		1/2/3	175	Phenolic	CU	1/0 - #14 AWG	1		1/0 - #14 AWG	1	
143X124		1/2/3	255	Phenolic	CU	250 kcmil - #6 AWG	1		250 kcmil - #6 AWG	1	
140X801		2/3	255	Phenolic	CU	250 kcmil - #6 AWG	1		250 kcmil - #6 AWG	1	
143X123		1/2/3	255	Phenolic	AL	250 kcmil - #6 AWG	1		250 kcmil - #6 AWG	1	
140X303		2/3	310	Phenolic	AL	350 kcmil - #6 AWG	1		350 kcmil - #6 AWG	1	
143X126		1/2/3	310	Phenolic	AL	350 kcmil - #6 AWG	1		350 kcmil - #6 AWG	1	

CH = Block is also available with hinge cover attached - include "CH" at end of part number when ordering (not available on Adder blocks) - See page 55 for available covers

See pages 52-54 for dimensional information

Power Splicer Blocks (cont.)

600 Volts AC/DC Up to 1000 Volts AC/DC (CE)⁺

Specifications:

- Connector, High Conductive Aluminum, Tin Plated, Rated for Copper and Aluminum Wire
- CU Connector, High Conductive Copper, Tin Plated, Rated for Copper Wire Only
- Amp Rating Based on NEC Table 310-16 Using 75°C Copper Wire
- UL Recognized File No. XCFR2.E62806
- CSA Certified File No. LR19766
- **CE**
- Flexible Stranded Wire Compliant
- RoHS Compliant
- **For detailed SCCR information with fuses and circuit breakers, please refer to datasheets on www.marathonsp.com**



1443557



1453129

+ Refer to www.marathonsp.com/PDFs/1000VCERating.pdf for details on availability of CE voltage ratings greater than 600 Volts

Replace "X" with # of poles

Catalog #	Hinge Cover	Poles (X)	Amps	MATERIAL		LINE SIDE			LOAD SIDE		
				Insulator	Conn.	Wire Range AWG/kcmil	Openings Per Pole	Connector Configuration	Wire Range AWG/kcmil	Openings Per Pole	Connector Configuration
133X126	CH	1/2/3	310	Plastic	AL	350 kcmil - #6 AWG	1		350 kcmil - #6 AWG	1	
133X305	CH	1/2/3	350	Plastic	AL	2/0 - #14 AWG	2		2/0 - #14 AWG	2	
143X306		1/2/3	350	Phenolic	AL	2/0 - #14 AWG	2		2/0 - #14 AWG	2	
144X557		1/2/3	420	Phenolic	AL	600 kcmil - #4 AWG	1		600 kcmil - #4 AWG	1	
133X360	CH	1/2/3	420	Plastic	AL	600 kcmil - #2 AWG	1		600 kcmil - #2 AWG	1	
133X320	CH	1/2/3	510	Plastic	AL	250 kcmil - 1/0 AWG	2		250 kcmil - 1/0 AWG	2	
145X129		1/2/3	620	Phenolic	AL	350 kcmil - #4 AWG	2		350 kcmil - #4 AWG	2	
145X301		1/2/3	760	Phenolic	AL	500 kcmil - #4 AWG	2		500 kcmil - #4 AWG	2	

CH = Block is also available with hinge cover attached - include "CH" at end of part number when ordering - See page 55 for available covers

See pages 52-54 for dimensional information

Power Stud Blocks

600 Volts AC/DC Up to 1000 Volts AC/DC (CE)⁺

Specifications:

- Connector, High Conductive Copper, Tin Plated
- Stud, Brass, Tin Plated, Metric (M) Studs, Steel
- Suitable for Compression Wire Lugs
- UL Recognized File No. XCFR2.E62806
- CSA Certified File No. LR19766
- **CE**
- Flexible Stranded Wire Compliant
- RoHS Compliant
- **For detailed SCCR information with fuses and circuit breakers, please refer to datasheets on www.marathonsp.com**



1423122



1423123

+ Refer to www.marathonsp.com/PDFs/1000VCERating.pdf for details on availability of CE voltage ratings greater than 600 Volts

Replace "X" with # of poles (0 = Adder)

Catalog #	Hinge Cover	Poles (X)	Amps	MATERIAL		LINE SIDE			LOAD SIDE		
				Insulator	Conn.	Wire Range AWG/kcmil	Openings Per Pole	Connector Configuration	Wire Range AWG/kcmil	Openings Per Pole	Connector Configuration
132X122	CH	0/1/2/3	200	Plastic	CU	1/4-20 x 9/16	1		1/4-20 x 9/16	1	
132X422	CH	0/1/2/3	200	Plastic	CU	M6 x 15	1		M6 x 15	1	
142X123		1/2/3	200	Phenolic	CU	1/4-20 Screw	1		1/4-20 Screw	1	
142X122		1/2/3	200	Phenolic	CU	1/4-20 x 9/16	1		1/4-20 x 9/16	1	
143X563		1/2/3	230	Phenolic	CU	3/8-16 x 1 3/16	1		3/8-16 x 1 3/16	1	
143X561		1/2/3	230	Phenolic	CU	3/8-16 x 1 3/16	1		1/4-20 x 1 3/16	1	
144X553		1/2/3	230	Phenolic	CU	3/8-16 x 1 7/16	1		3/8-16 x 1 7/16	1	
144X122		1/2/3	260	Phenolic	CU	3/8-16 x 1 7/16	1		1/4-20 x 1 9/16	2	
133X564	CH	1/2/3	310	Plastic	CU	M10 X 30	1		M10 X 30	1	
133X563	CH	1/2/3	310	Plastic	CU	3/8-16 x 1 3/16	1		3/8-16 x 1 3/16	1	
145X573		1/2/3	360	Phenolic	CU	3/8-16 x 1 7/16	1		3/8-16 x 1 7/16	2	
145X583		1/2/3	360	Phenolic	CU	3/8-16 x 1 7/16	1		1/4-20 X 1 7/16	2	
145X606		1/2/3	410	Phenolic	CU	1/2-13 x 1 7/16	1		1/2-13 x 1 7/16	1	
144X614		1/2/3	840	Phenolic	CU	3/8-16 x 1	1		3/8-16 x 1	1	

CH = Block is also available with hinge cover attached - include "CH" at end of part number when ordering (not available on Adder blocks) - See page 55 for available covers

See pages 52-54 for dimensional information

Miscellaneous Power Splicer Blocks

600 Volts AC/DC Up to 1000 Volts AC/DC (CE)⁺

Specifications:

- Connector, High Conductive Aluminum, Tin Plated
- Rated for Copper and Aluminum Wire
- Stud, Brass, Tin Plated
- Quick Connect, Brass, Tin Plated
- 10-32 Screw, Brass, Nickel Plated
- Amp Rating Based on NEC Table 310-16 Using 75°C Copper Wire
- UL Recognized File No. XCFR2.E62806
- CSA Certified File No. LR19766
- **CE**
- Flexible Stranded Wire Compliant
- RoHS Compliant
- **For detailed SCCR information with fuses and circuit breakers, please refer to datasheets on www.marathonsp.com**













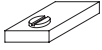

1413202



1413205

+ Refer to www.marathonsp.com/PDFs/1000VCERating.pdf for details on availability of CE voltage ratings greater than 600 Volts

Replace "X" with # of poles

Catalog #	Poles (X)	Amps	MATERIAL		LINE SIDE			LOAD SIDE		
			Insulator	Conn.	Wire Range AWG/kcmil	Openings Per Pole	Connector Configuration	Load Connection	Openings Per Pole	Connector Configuration
141X200	1/2/3/4	115	Plastic	AL	#2 - #14 AWG	1		10-32 Screw	1	
141X201	1/2/3/4	115	Plastic	AL	#2 - #14 AWG	1		10-32 Tapped Hole	1	
141X202	1/2/3/4	115	Plastic	AL	#2 - #14 AWG	1		.25 x .032 QC	4	
141X205	1/2/3/4	115	Plastic	AL	#2 - #14 AWG	1		#10-32 Hole & (2) QC	1	
141X301	1/2/3/4	115	Plastic	AL	#2 - #14 AWG	1		#2 - #14 AWG & (1) QC	1	
142X411	1/2/3	175	Phenolic	AL	2/0 - #14 AWG	1		M6 Hole	1	
142X553	1/2/3	175	Phenolic	AL	2/0 - #14 AWG	1		1/4-20 Tapped Hole	1	

See page 55 for available covers

See pages 52-54 for dimensional information

Power Splicer/Stud Blocks

600 Volts AC/DC Up to 1000 Volts AC/DC (CE)⁺

Specifications:

- Connector, High Conductive Aluminum, Tin Plated, Rated for Copper and Aluminum Wire
- Stud, Brass, Tin Plated, Metric (M) Studs, Steel - intended for wires terminated with crimp lugs
- Amp Rating Based on NEC Table 310-16 Using 75°C Copper Wire
- UL Recognized File No. XCFR2.E62806
- CSA Certified File No. LR19766
- CE (does not apply to 133X559, 133X558, and 143X559)
- Flexible Stranded Wire Compliant
- RoHS Compliant
- **For detailed SCCR information with fuses and circuit breakers, please refer to datasheets on www.marathonsp.com**

+ Refer to www.marathonsp.com/PDFs/1000VCERating.pdf for details on availability of CE voltage ratings greater than 600 Volts



1433559



1453599

** Openings rated for #4-14 AWG are multiple wire rated:
(2) #10 CU Str, (2 to 4) #12 CU Str, and (2 to 4) #14 CU Str.

*** Openings rated for #2-14 AWG are multiple wire rated:
(2) #8 CU Str, (2) #10 CU Str, (2) #12 CU Str, and (2) #14 CU Str.

Replace "X" with # of poles (0 = Adder)

Catalog #	Hinge Cover	Poles (X)	Amps	MATERIAL		LINE SIDE			LOAD SIDE		
				Insulator	Conn.	Wire Range AWG/kcmil	Openings Per Pole	Connector Configuration	Wire Range AWG/kcmil	Openings Per Pole	Connector Configuration
141X203		1/2/3/4	115	Plastic	AL	#2 - #14 AWG	1		10-32 X .60 Stud	1	
132X574	CH	0/1/2/3	175	Plastic	AL	2/0 - #14 AWG	1		1/4-20 x 1/2	1	
132X474	CH	0/1/2/3	175	Plastic	AL	2/0 - #14 AWG	1		M6 x 13	1	
142X574		1/2/3	175	Phenolic	AL	2/0 - #14 AWG	1		1/4-20 x 1/2	1	
143X590		1/2/3	175	Phenolic	AL	2/0 - #14 AWG	1		1/4-20 x 1 3/8	1	
143X559		1/2/3	310	Phenolic	AL	350 kcmil - #6 AWG	1		3/8-16 x 11/8 Stud	1	
133X559	CH	1/2/3	310	Plastic	AL	350 kcmil - #6 AWG	1		3/8-16 x 1 1/4	1	
133X558	CH	1/2/3	310	Plastic	AL	350 kcmil - #6 AWG	1		M10 x 30	1	
144X569		1/2/3	380	Phenolic	AL	500 kcmil - #4 AWG	1		1/4-20 x 1 1/16	2	
144X575		1/2/3	380	Phenolic	AL	500 kcmil - #4 AWG	1		3/8 - 16 x 1 5/16	1	
145X596		1/2/3	545	Phenolic	AL	1000 kcmil - 500 kcmil	1		3/8 - 16 x 1 3/16	2	
145X599		1/2/3	760	Phenolic	AL	500 kcmil - #4 AWG	2		3/8 - 16 x 1 5/16	2	
145X610		1/2/3	760	Phenolic	AL	500 kcmil - #4 AWG	2		1/2-13 x 1 5/16	1	

CH = Block is also available with hinge cover attached - include "CH" at end of part number when ordering (not available on Adder blocks) - See page 55 for available covers

See pages 52-54 for dimensional information

Power Stud to Distribution Blocks

600 Volts AC/DC Up to 1000 Volts AC/DC (CE)⁺

Specifications:

- Connector, High Conductive Aluminum, Tin Plated, Rated for Copper and Aluminum Wire
 - Stud, Brass, Tin Plated, Metric (M) Studs, Steel - intended for wires terminated with crimp lugs
 - Amp Rating Based on NEC Table 310-16 Using 75°C Copper Wire
 - UL Recognized File No. XCFR2.E62806
 - CSA Certified File No. LR19766
 - CE
 - Flexible Stranded Wire Compliant
 - RoHS Compliant
 - **For detailed SCCR information with fuses and circuit breakers, please refer to datasheets on www.marathonsp.com**
- + Refer to www.marathonsp.com/PDFs/1000VCERating.pdf for details on availability of CE voltage ratings greater than 600 Volts

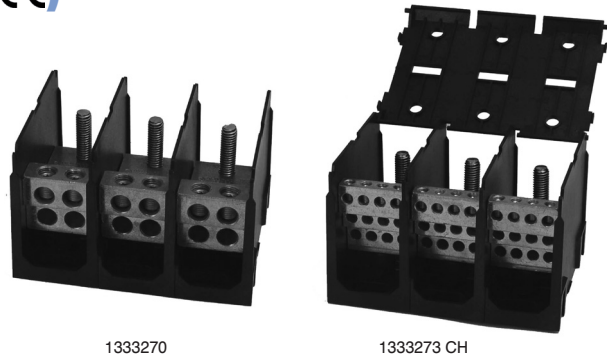

** Openings rated for #4-14 AWG are multiple wire rated:
(2) #10 CU Str, (2 to 4) #12 CU Str, and (2 to 4) #14 CU Str.

*** Openings rated for #2-14 AWG are multiple wire rated:
(2) #8 CU Str, (2) #10 CU Str, (2) #12 CU Str, and (2) #14 CU Str.

Replace "X" with # of poles

Catalog #	Hinge Cover	Poles (X)	Amps	MATERIAL		LINE SIDE			LOAD SIDE		
				Insulator	Conn.	Threaded Stud Size	Openings Per Pole	Connector Configuration	Wire Range AWG/kcmil	Openings Per Pole	Connector Configuration
133X272	CH	1/2/3	510	Plastic	AL	3/8-16 x 1 3/16"	1		#4 - #14 AWG**	12	
133X273	CH	1/2/3	510	Plastic	AL	M10 x 30	1		#4 - #14 AWG**	12	
133X280	CH	1/2/3	510	Plastic	AL	3/8-16 x 1 3/16"	1		#2 - #14 AWG***	8	
133X281	CH	1/2/3	510	Plastic	AL	M10 x 30	1		#2 - #14 AWG***	8	
133X270	CH	1/2/3	510	Plastic	AL	3/8-16 x 1 3/16"	1		2/0 - #14 AWG***	4	
133X271	CH	1/2/3	510	Plastic	AL	M10 x 30	1		2/0 - #14 AWG***	4	

CH = Block is also available with hinge cover attached - include "CH" at end of part number when ordering - See page 55 for available covers

See pages 52-54 for dimensional information

Power Terminal Block Dimensions

132 SERIES

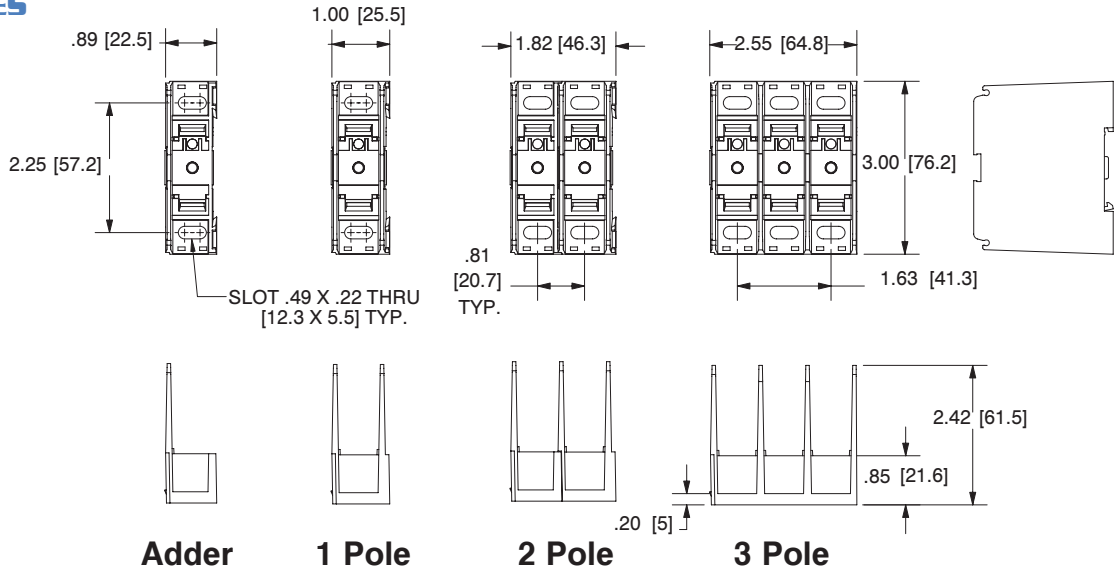

132 CH SERIES

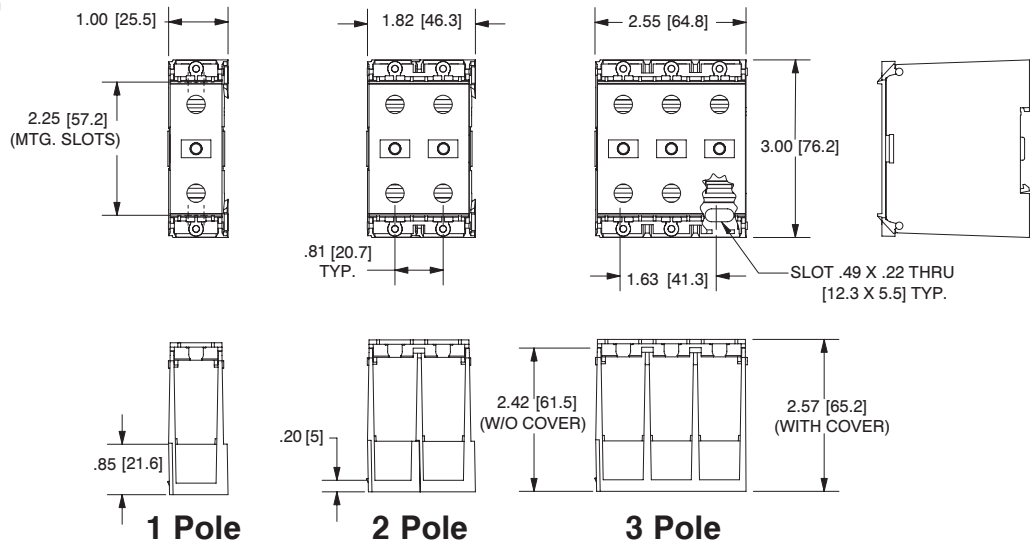

133 SERIES

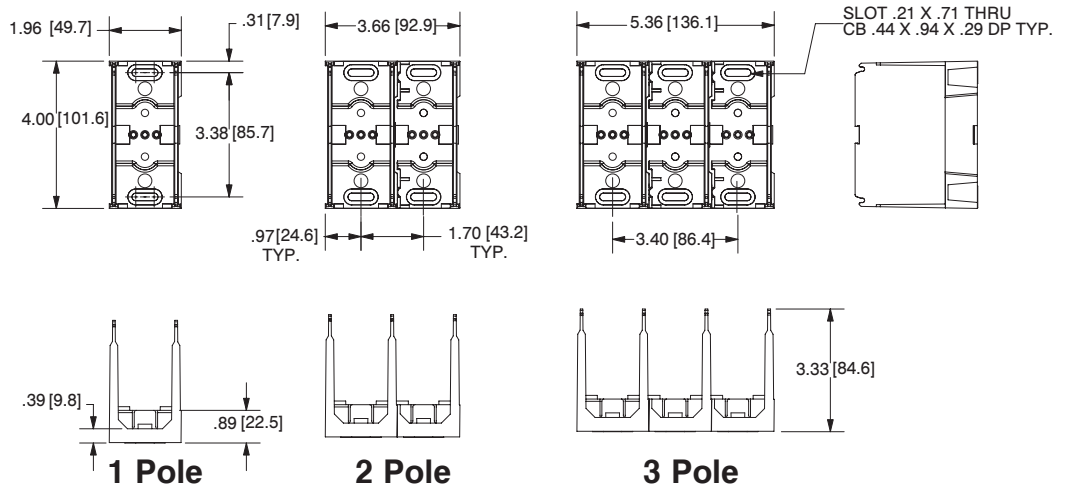

For electronic drawings or 2D/3D CAD data, send request to drawings@marathonsp.com

Power Terminal Block Dimensions

133 CH SERIES

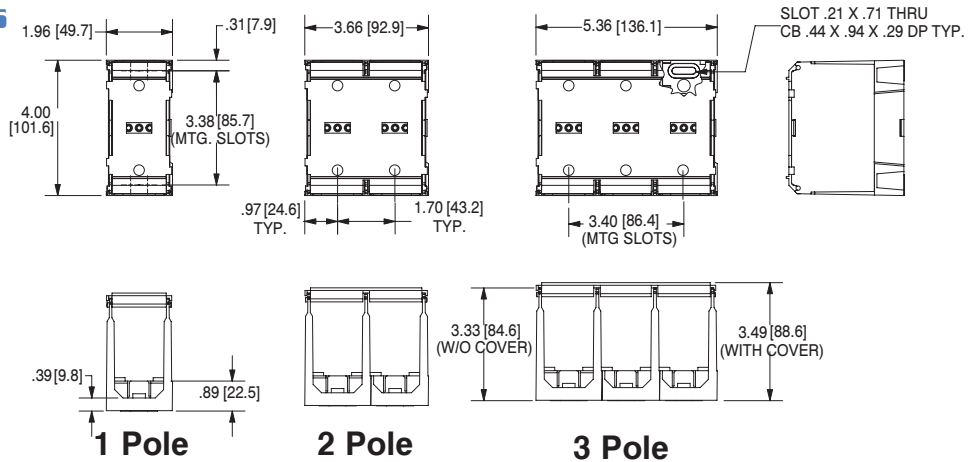

140 SERIES

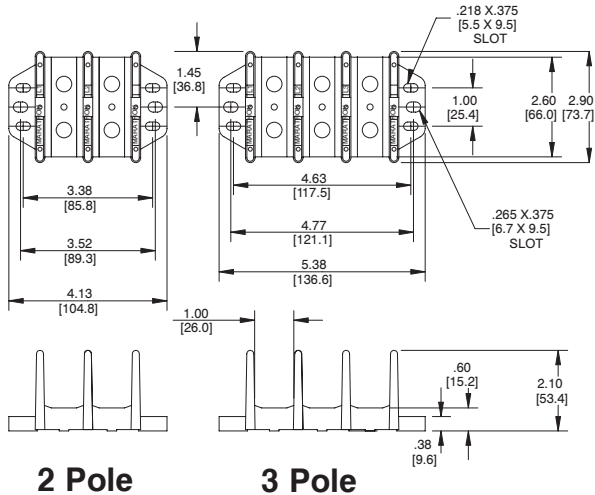

142 SERIES

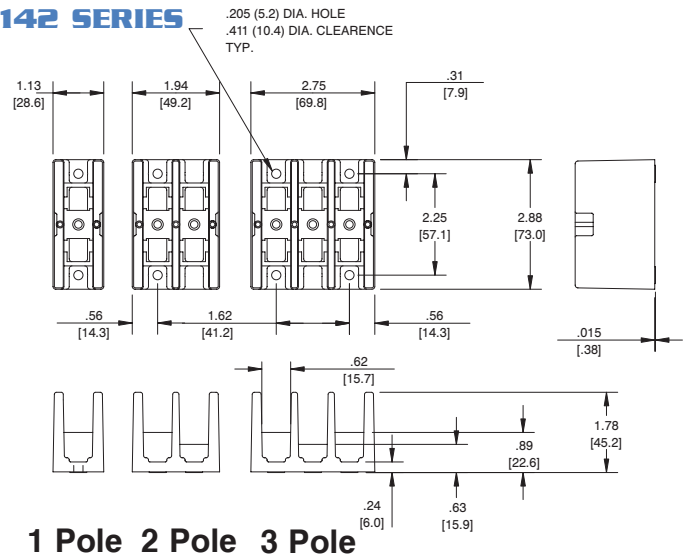

141 SERIES

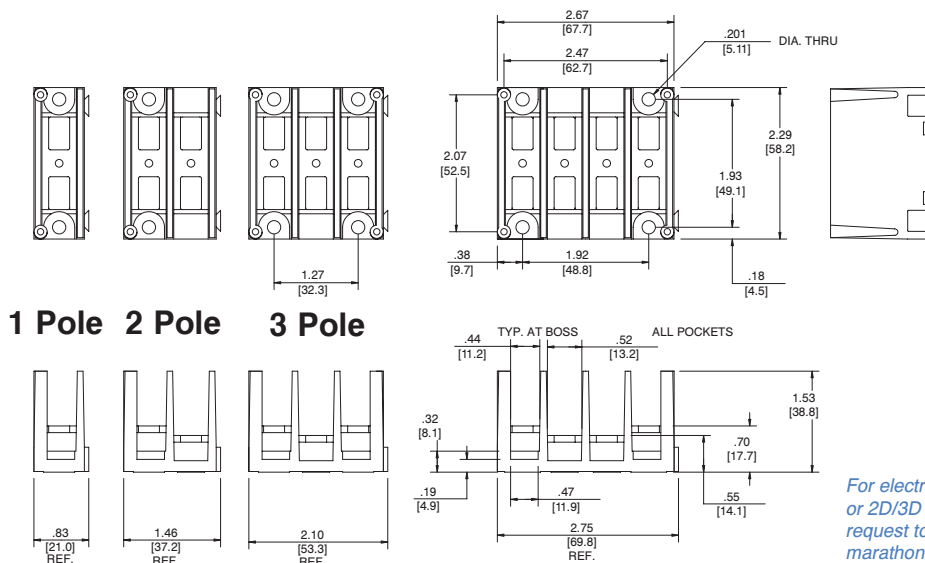

For electronic drawings or 2D/3D CAD data, send request to drawings@marathonsp.com

Power Terminal Block Dimensions

143 SERIES

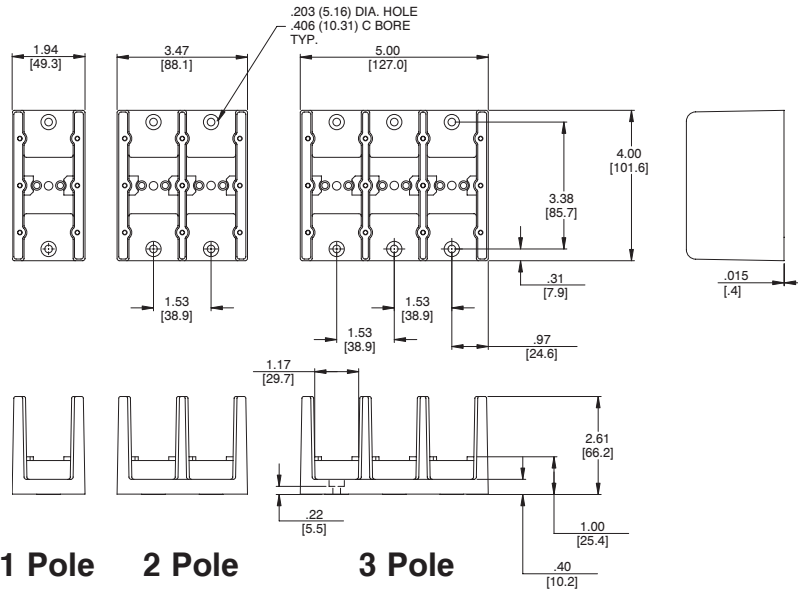

144 SERIES

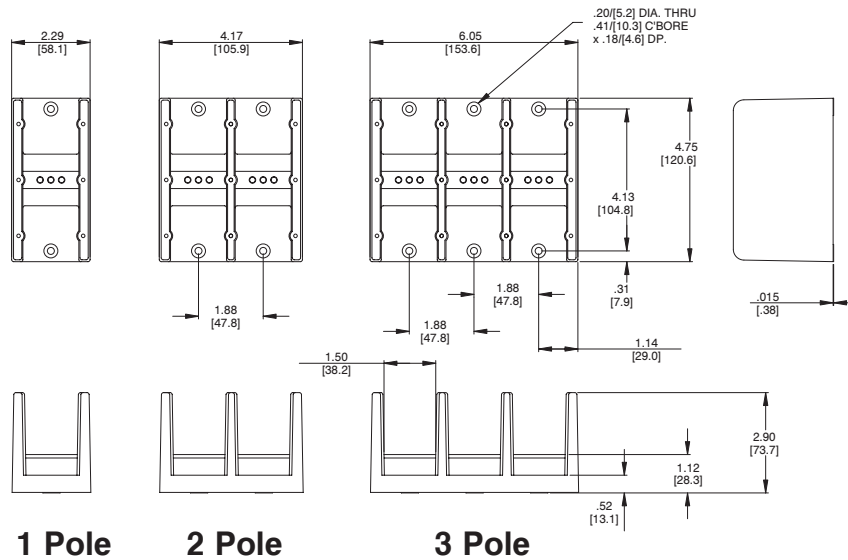

145 SERIES

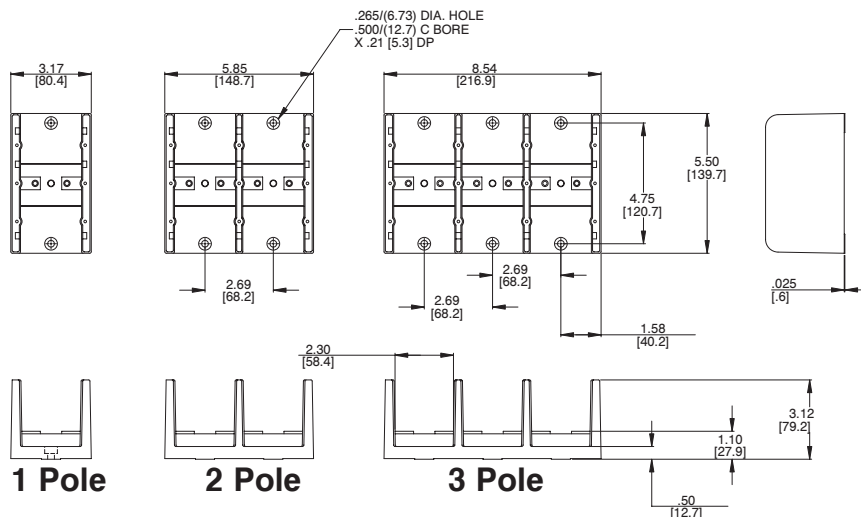

For electronic drawings or 2D/3D CAD data, send request to drawings@marathonsp.com

Power Block Covers

Specifications:

140/141/142/143/144/145 Series (Figures 1 & 2)

- Material UL Recognized, QMFZ2, 125°C, .06 Clear Protective Plastic
- Two Thread Cutting Screws Furnished Per Cover
- Covers are Slotted for Easy Installation
- RoHS Compliant

132/133 Series (Figure 3)

- Snap on, Hinged Cover, Black Thermoplastic
- UL Recognized, QMFZ2, 125°C
- RoHS Compliant

Dimensions (in):

Catalog #	A	B	Figure #
CC1402	2.75	2.25	1
CC1403	4.00	2.25	
CC1411	0.77	2.40	2
CC1412	1.42	2.40	
CC1413	2.05	2.40	
CC1414	2.68	2.40	
CC1421	1.06	2.75	1
CC1422	1.87	2.75	
CC1423	2.68	2.75	
CC1431	1.78	3.38	1
CC1432	3.31	3.38	
CC1433	4.84	3.38	
CC1441	2.12	4.00	1
CC1442	4.00	4.00	
CC1443	5.87	4.00	
CC1451	2.87	4.50	1
CC1452	5.56	4.50	
CC1453	8.28	4.50	
CH1321	-	-	3
CH1322	-	-	
CH1323	-	-	
CH1331	-	-	3
CH1332	-	-	
CH1333	-	-	

For electronic drawings or 2D/3D CAD data, send request to drawings@marathonsp.com

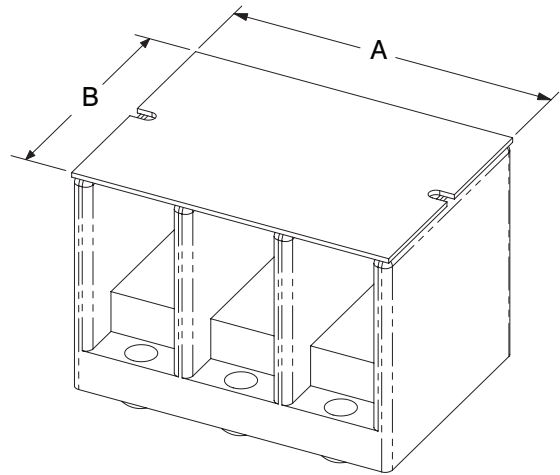

FIGURE 1

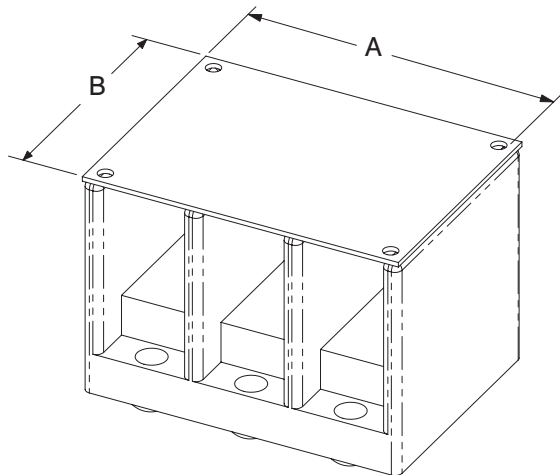

FIGURE 2

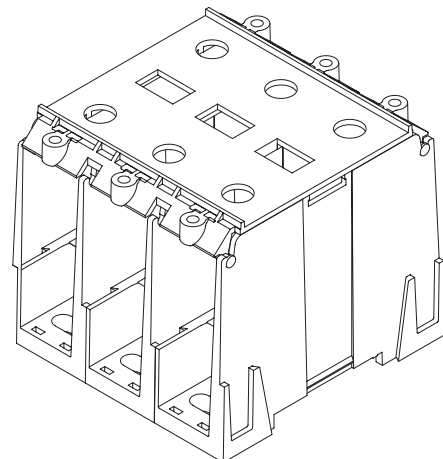

FIGURE 3
(Hinged Cover)

Grounding Lugs

Specifications:

- Connector, High Conductive Aluminum, Tin Plated
- Screw head is green ink
- Flexible Stranded Wire Compliant
- UL Recognized File No. ZMVV2.E43665
- CSA Certified File No. 63510-25
- RoHS Compliant

Catalog # (Part #)	Wire Range AWG/kcmil	Torque lb in
GL02 (9807052)	#2 - #3	50
	#4 - #6	45
	#8	40
	#10 - #14	35

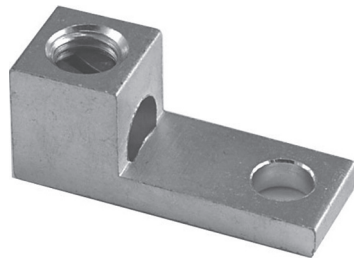

Catalog # (Part #)	Wire Range AWG/kcmil	Torque lb in
GL20 (9718102)	2/0 - #6	120
	#8	40
	#10 - #14	35

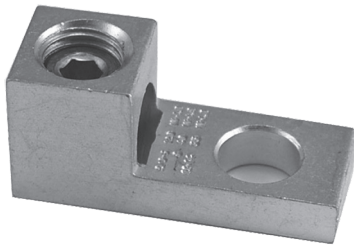

Catalog # (Part #)	Wire Range AWG/kcmil	Torque lb in
GL35 (9819830)	350 kcmil - #6	375



GL02:

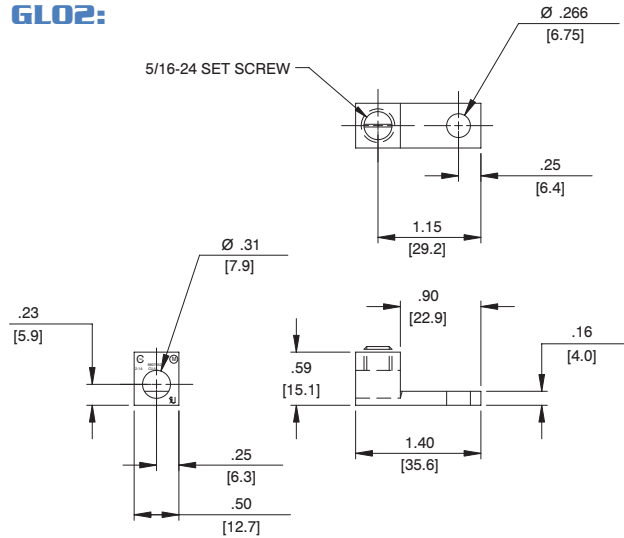

GL20:

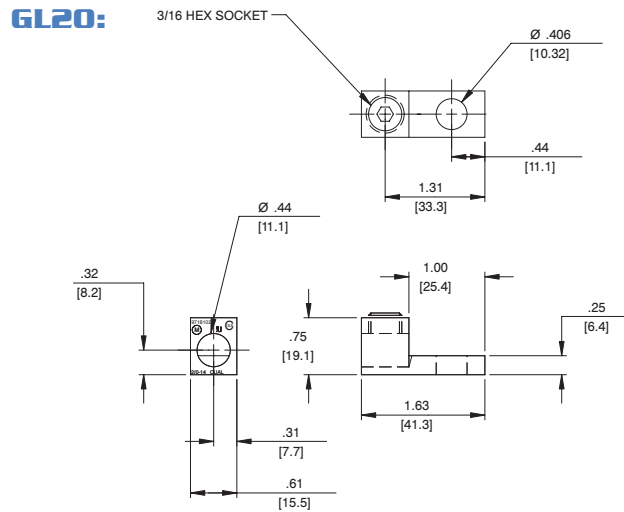

GL35:

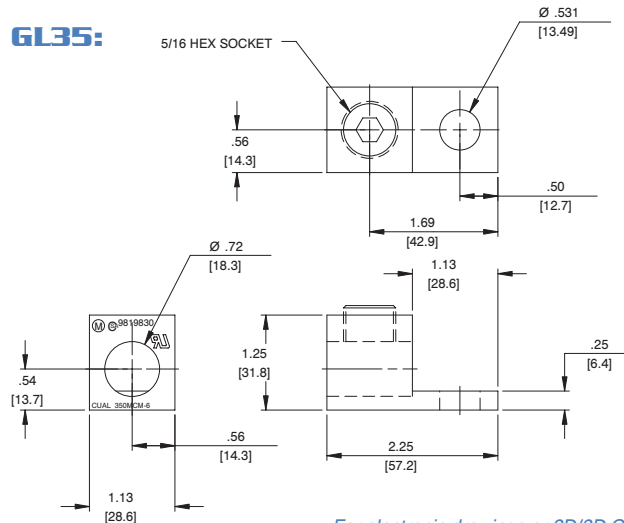

For electronic drawings or 2D/3D CAD data, send request to drawings@marathonsp.com

Studded Power Feed Thru Terminal Blocks

ST722 Series

The Studded Power Feed Thru Terminal Blocks were designed for applications where power feed thru is necessary using standard double hole lugs with .625" spacing.

These terminal blocks are available in three mounting options (end mount, back mount, and slide-in mount). They are also offered in various line lengths and with various hardware options (See Hardware Descriptions Below).

These terminal blocks lower cost by eliminating multiple components and assembly time. The terminal blocks are manufactured from top quality insulator and conductor materials. They are designed with a robust one-piece insulator base using a one-piece conductor permanently assembled together.

Covers are molded using a one-piece design and are available as an option for all three series of these blocks.

Series	Mounting	Stud (Thread Size)		Poles		Hardware	
ST722	B	2	5	0	2		
	B – Back Mount S – Slide Mount E – End Mount	19 - #10-32 Stud 25 - 1/4" - 20 Stud M5 - M5 Stud M6 - M6 Stud		(Back Mount) 02 – 06 (Slide Mount) 01 – 04 (End Mount) 01 – 06		(blank) – No hardware UH – All nuts shipped bulk AH – All nuts assembled DL – Assembled barrier side, remainder shipped bulk	

Optional Cover Available:

- Cover is offered in 1 – 6 poles
- One cover accommodates all series
- Base, Thermoplastic
- Flammability UL 94 V-0

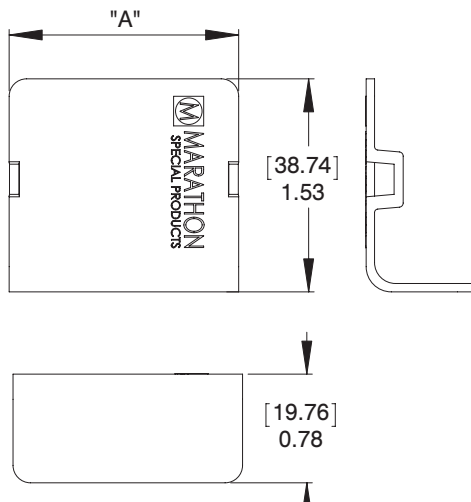

Catalog Number	Number of Poles	Dimensions A	
		Inches	Metric
C72201	1	0.91	(23.11)
C72202	2	1.64	(41.66)
C72203	3	2.37	(60.20)
C72204	4	3.10	(78.74)
C72205	5	3.83	(97.28)
C72206	6	4.56	(115.82)



For electronic drawings or 2D/3D CAD data, send request to drawings@marathonsp.com

Studded Power Feed Thru Terminal Blocks

Specifications:

Electrical:

- 300 Volts AC/DC (UL 1059 Class B and C)
- 175 Amps
- Wire Range 2/0 - #8
- Accommodates Two Hole Compression Lugs on .625" Centers – wires #2 and larger may require narrow lugs

General/Mechanical:

- Base, Thermoplastic, 125°C (UL RTI)
- Studs, Brass, Nickel Plated
- 2 – 6 Poles
- .73" Centers
- Application Torque: 35 lbf-in for #10 - 32 and M5.
50 lbf-in for 1/4" - 20 and M6
- UL Recognized File No. XCFR2.E62806
- CSA Certified File No. LR19766
- CE
- RoHS Compliant

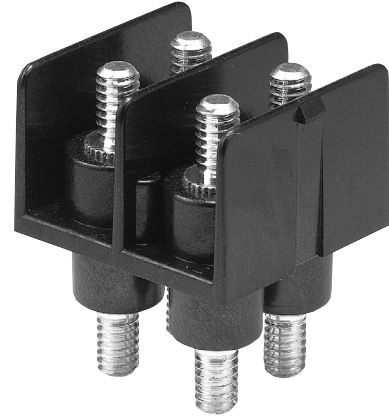

ST722B2502

Catalog Number	Number of Poles	Dimensions A	
		Inches	Metric
ST722BXX02	2	1.55	(39.37)
ST722BXX03	3	2.28	(57.91)
ST722BXX04	4	3.01	(75.45)
ST722BXX05	5	3.74	(95.00)
ST722BXX06	6	4.47	(113.54)

Replace XX with thread size: 19 - #10-32 Stud
25 - 1/4" - 20 Stud
M5 - M5 Stud
M6 - M6 Stud

See page 57 for available covers

LENGTH	"P"	
	ENG.	MET.
1-LINE	.62	15.7
2-LINE	1.35	34.3
3-LINE	2.08	52.8
4-LINE	2.81	71.4
5-LINE	3.54	89.9
6-LINE	4.27	108.5

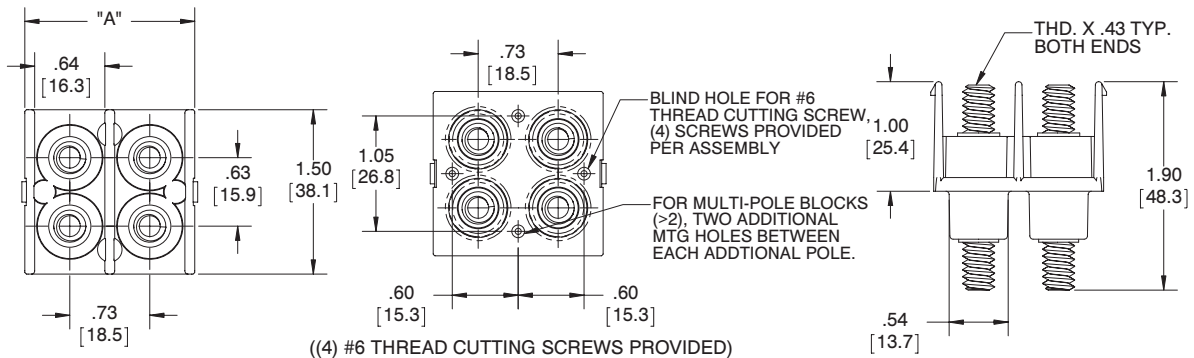
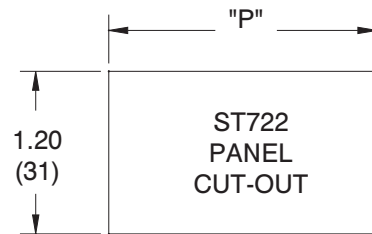

For electronic drawings or 2D/3D CAD data, send request to drawings@marathonsp.com

Studded Power Feed Thru Terminal Blocks

ST722S Series (slide-in mount)

Specifications:

Electrical:

- 300 Volts AC/DC (UL 1059 Class B and C)
- 175 Amps
- Wire Range 2/0 - #8
- Accommodates Two Hole Compression Lugs on .625" Centers – wires #2 and larger may require narrow lugs

General/Mechanical:

- Base, Thermoplastic, 125°C (UL RTI)
- Studs, Brass, Nickel Plated
- 1 - 4 Poles
- .73" Centers
- Application Torque: 35 lbf-in for #10 - 32 and M5.
50 lbf-in for 1/4" - 20 and M6
- UL Recognized File No. XCFR2.E62806
- CSA Certified File No. LR19766
- CE
- RoHS Compliant

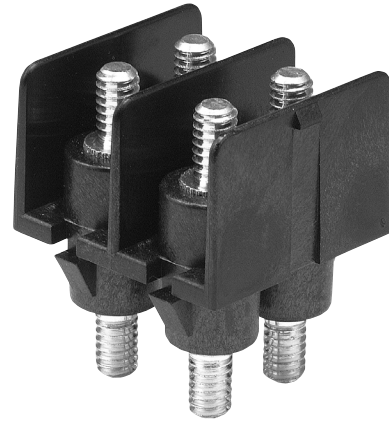

ST722S2502

Catalog Number	Number of Poles	Dimensions A	
		Inches	Metric
ST722SXX01	1	0.82	(20.83)
ST722SXX02	2	1.55	(39.37)
ST722SXX03	3	2.28	(57.91)
ST722SXX04	4	3.01	(76.45)

Replace XX with thread size: 19 - #10-32 Stud
25 - 1/4" - 20 Stud
M5 - M5 Stud
M6 - M6 Stud

See page 57 for available covers

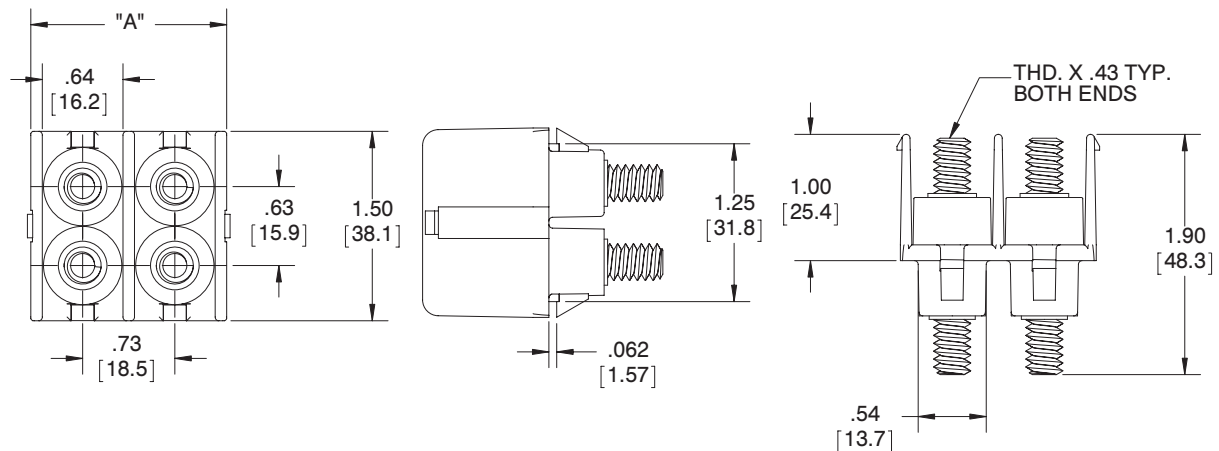

For electronic drawings or 2D/3D CAD data, send request to drawings@marathonsp.com

Studded Power Feed Thru Terminal Blocks

ST722E Series (end mount)

Specifications:

Electrical:

- 300 Volts AC/DC (UL 1059 Class B and C)
- 175 Amps
- Wire Range 2/0 - #8
- Accommodates Two Hole Compression Lugs on .625" Centers – wires #2 and larger may require narrow lugs

General/Mechanical:

- Base, Thermoplastic, 125°C (UL RTI)
- Studs, Brass, Nickel Plated
- 1 - 6 Poles
- .73" Centers
- Application Torque: 35 lbf-in for #10 - 32 and M5.
50 lbf-in for 1/4" - 20 and M6
- UL Recognized File No. XCFR2.E62806
- CSA Certified File No. LR19766
- CE
- RoHS Compliant

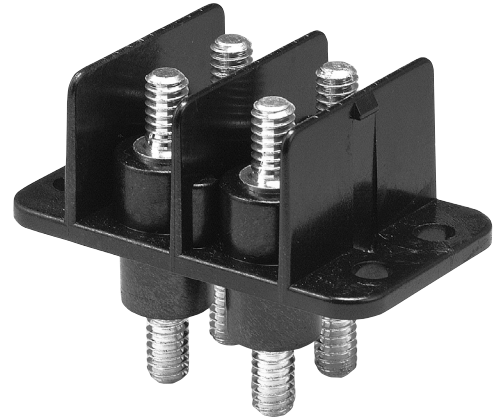

ST722E2503

LENGTH	"P1"	"P2"
1-LINE	1.32	.66
2-LINE	2.05	1.39
3-LINE	2.78	2.12
4-LINE	3.51	2.85
5-LINE	4.24	3.58
6-LINE	4.97	4.31

Catalog Number	Number of Poles	Dimensions A		Dimensions B	
		Inches	Metric	Inches	Metric
ST722EXX01	1	1.77	(44.96)	1.32	(33.53)
ST722EXX02	2	2.50	(63.50)	2.05	(52.07)
ST722EXX03	3	3.23	(82.40)	2.78	(70.61)
ST722EXX04	4	3.96	(100.58)	3.51	(89.15)
ST722EXX05	5	4.69	(119.13)	4.24	(107.70)
ST722EXX06	6	5.42	(137.67)	4.97	(126.24)

Replace XX with thread size: 19 - #10-32 Stud
25 - 1/4" - 20 Stud
M5 - M5 Stud
M6 - M6 Stud

See page 57 for available covers

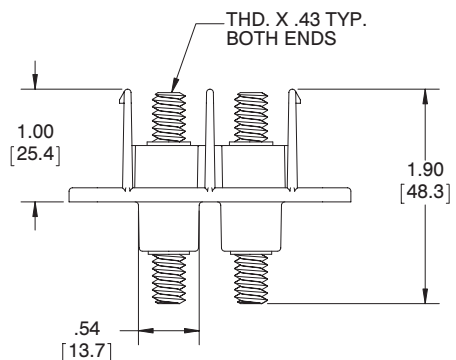
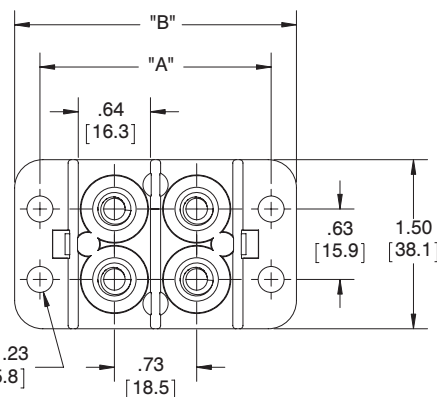
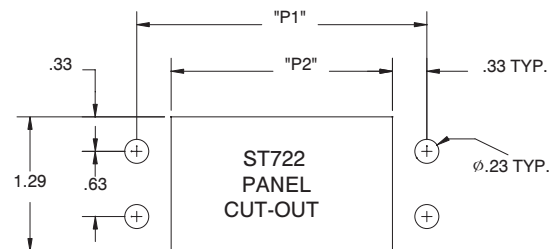

For electronic drawings or 2D/3D CAD data, send request to drawings@marathonsp.com

Studded Power Feed Thru Terminal Blocks

ST715S1902

Specifications:

Electrical:

- 300 Volts AC/DC (UL 1059 Class B and C)
- 80 Amps
- Wire Range #6 - #14
- Accommodates Two Hole Compression Lugs on .625" Centers

General/Mechanical:

- Base, Thermoplastic, 125°C (UL RTI)
- Studs, Brass, Nickel Plated
- 2 Poles
- .56" Centers
- Application Torque: 35 lbf-in
- UL Recognized File No. XCFR2.E62806
- cUR Certified File No. XCFR2.E62806
- CE
- RoHS Compliant

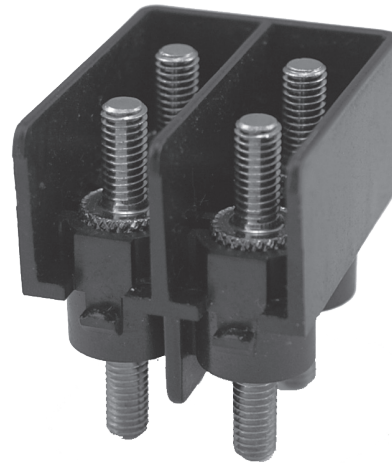

ST715S1902

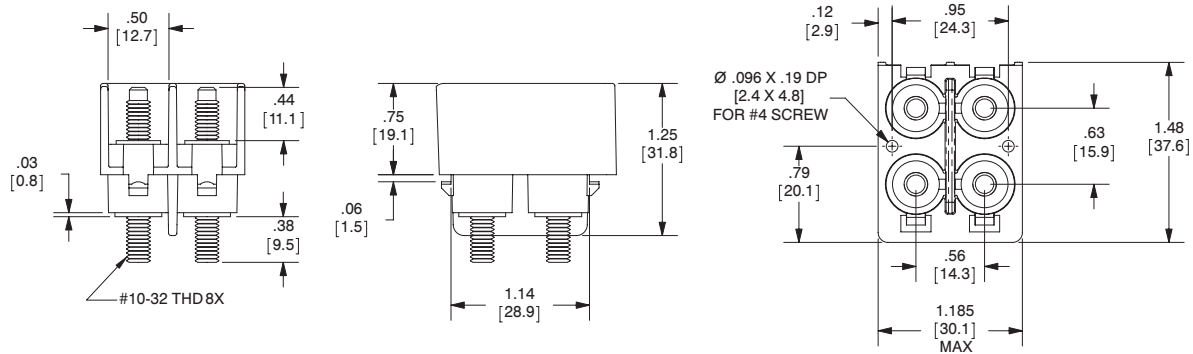

((1) #4 THREAD CUTTING SCREW PROVIDED)

Optional Cover: C71502

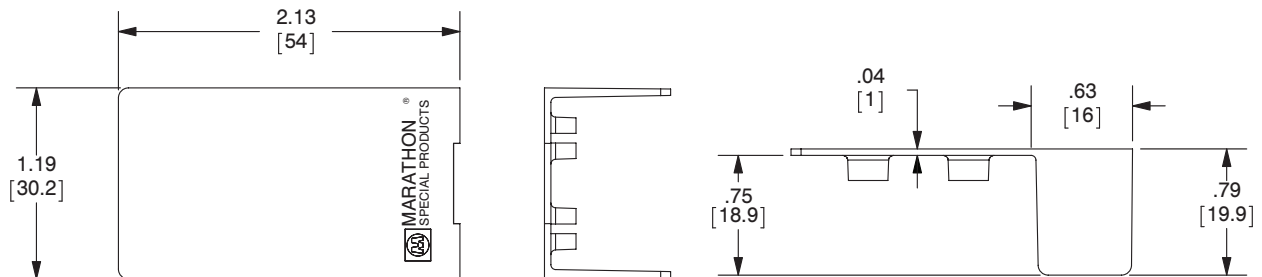

For electronic drawings or 2D/3D CAD data, send request to drawings@marathonsp.com

Studded Power Feed Thru Terminal Blocks

ST723B38 Series (back mount)

Specifications:

Electrical:

- 600 Volts AC/DC (UL 1059 Class B and C)
- 380 Amps
- Wire Range 500 kcmil - 2/0 AWG
- Accommodates Two Hole Compression Lugs on 1" Centers - wires larger than 250 kcmil require narrow lug

Mechanical:

- Base, Thermoplastic, 125°C (UL RTI)
- Flammability, UL 94 V-O
- Studs, 3/8" - 16, Brass, Nickel Plated
- Mounting hardware included (4) #10-32 Screws
- Application Torque: 192 lbf-in
- UL Recognized File No. XCFR2.E62806
- cUR Certified File No. XCFR2.E62806
- RoHS Compliant



ST723B3802

ST723B3801 - One Pole

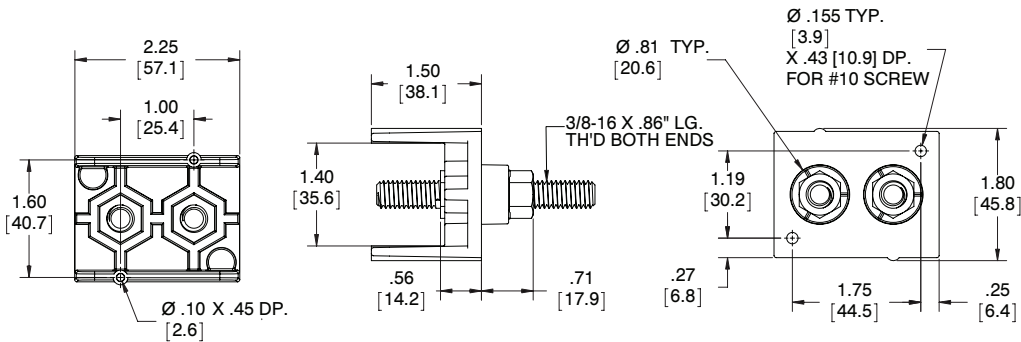

ST723B3802 - Two Poles

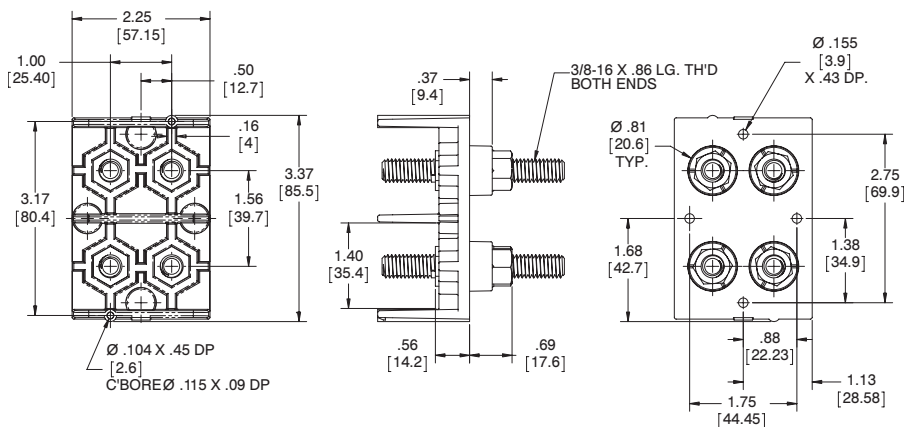

For electronic drawings or 2D/3D CAD data, send request to drawings@marathonsp.com

Single Stud Connection Block

Specifications:

- Base, Thermoplastic
- Temperature Rating of 125°C (UL RTI)
- Hardware, Stainless Steel
- 300 Volt AC/DC
- Recommended Mounting Screw 1/4"
- Available with two stud sizes: 5/16" or 3/8"
- Designed for two or more wire lugs
- RoHS Compliant



ST 710 38

Studded Feed Thru

Catalog # ST 710 31 5/16" Stud

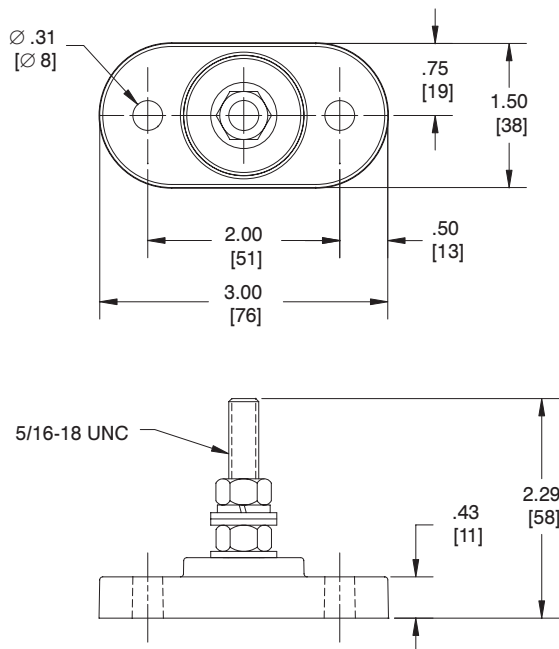

Catalog # ST 710 38 3/8" Stud

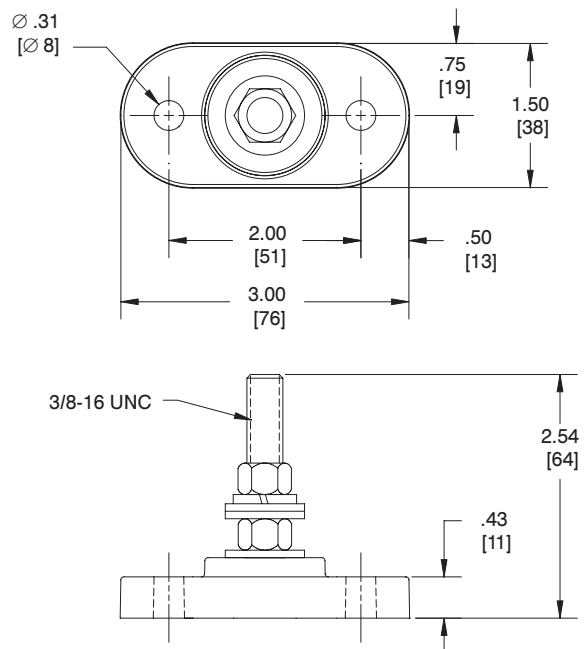

For electronic drawings or 2D/3D CAD data, send request to drawings@marathonsp.com

Heavy Duty Terminal Blocks

General Information:

Heavy Duty Terminal Blocks are available in two styles – Deadfront Type (1100, 1200, 985 and 0987 series) and Barrier Type (1500, 1600 and 1700 series).

Ratings and Standards:

The voltage ratings of terminal blocks are based upon the minimum spacing between electrically conductive parts line to line through air and over surface, and line to ground through air and over surface.

Class A

Service equipment including deadfront switchboards, panel boards, service entrance devices.

Class B

Commercial appliances including business equipment, electronic data processing equipment and the like.

Class C

General industrial and machine tool controls which can be further defined as equipment falling under UL 508. Ratings based on UL 1059 may be higher in some cases depending on application.

Spacing Requirements*:

	Voltage	Thru Air	Over Surface
Class A	51-150	.500	.750
	151-300	.750	1.250
	301-600	1.000	2.000
Class B	51-150	.063	.063
	151-300	.094	.094
	301-600	.375	.500
Class C	51-150	.125	.250
	151-300	.250	.375
	301-600	.375	.500

*In Inches

Applications:

These rugged terminal blocks are widely used in such industries as traffic control, utilities, switchgear and other utility related applications, such as windpower.

Heavy Duty Terminal Blocks

1100 Series - Deadfront Type

600 Volts AC/DC (UL/CSA)
630 Volts (CE)



1106

Specifications:

- Base, General Purpose Phenolic, 150°C
- Connector, Aluminum Tin Plated
- Spring, Copper, Use 11XXS
- Screws, Brass, Tin Plated
- Current Rating up to **65 Amps**
- Wire Range #6 - #18 AWG CU
- Wire Range With Spring #6 - #14 AWG CU
- UL Recognized File No. XCFR2.E62806
- CSA Certified File No. LR19766
- CE
- RoHS Compliant

Heavy Duty Terminal Blocks

Catalog Number		# of Poles	Dimensions	
			A	B
1102	1102S	2	1.69	1.31
1104	1104S	4	2.50	2.12
1106	1106S	6	3.38	3.00
1107	1107S	7	3.88	3.50
1108	1108S	8	4.25	3.88
1112	1112S	12	6.00	5.62

S=Copper Pressure Spring
See page 34 for DIN Rail Adapter

mm = dim X 25.4

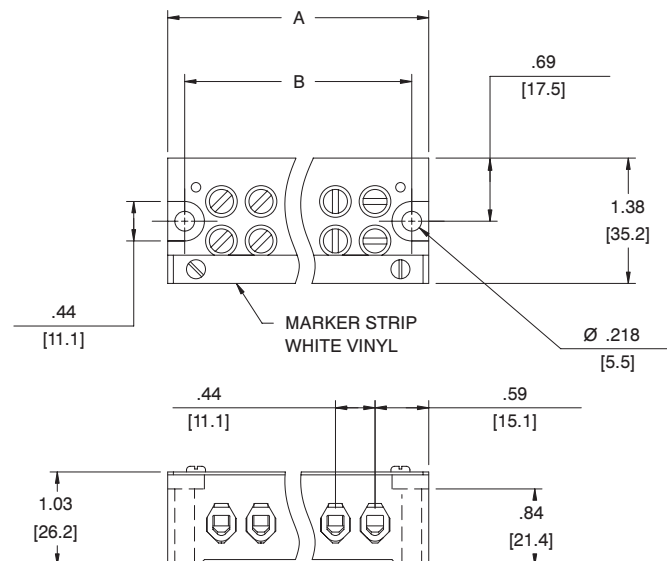

For electronic drawings or 2D/3D CAD data,
send request to drawings@marathonsp.com

Heavy Duty Terminal Blocks

1103P and 1200 Series - Deadfront Type

600 Volts AC/DC (UL/CSA)
 630 Volts (CE) - 1103P
 800 Volts (CE) - 1200 Series

Specifications:

- Base, General Purpose Phenolic, 150°C
- Connector, Aluminum, Tin Plated
- Screws, Steel, Nickel (Ni) Plated
- Current Rating up to **70 Amps**
- 1103P Wire Range #4 - #14 AWG CU
- 1200 Series Wire Range #4 - #18 AWG CU
- UL Recognized File No. XCFR2.E62806
- CSA Certified File No. LR19766
- **CE**
- RoHS Compliant

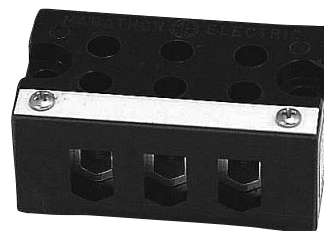

1103P



1206

Catalog #	# of Poles	Dimensions	
		A	B
1202	2	1.81	1.44
1204	4	2.81	2.44
1206	6	3.81	3.44

For electronic drawings or 2D/3D CAD data, send request to drawings@marathonsp.com

mm = dim X 25.4

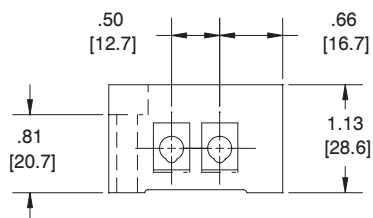
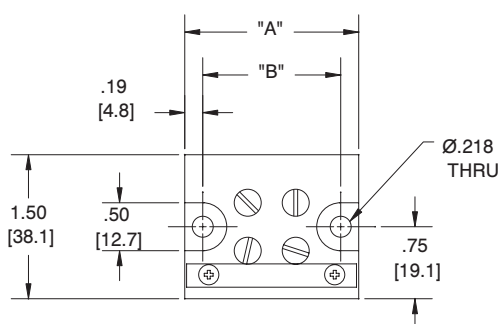

1200 Series

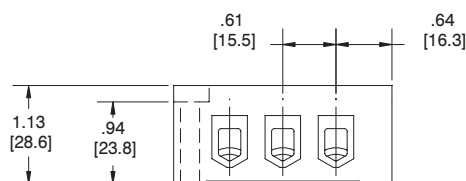
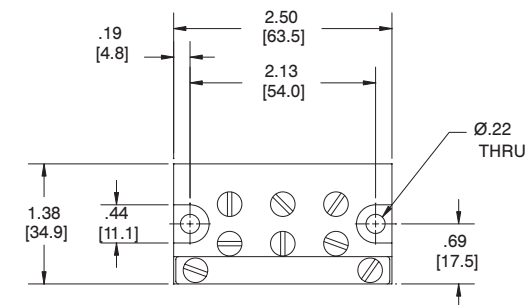

1103P Series

Heavy Duty Terminal Blocks

0987 RZ Series - Deadfront Type

600 Volts AC/DC (UL/CSA)
1000 Volts (CE)



0987 RZ TC 07

Specifications:

- Base, Thermoplastic, 125°C, Flammability - UL 94 V-O
- Connector, Copper Alloy, Nickel Plated (TC Tubular Clamp)
- Current Rating up to **50 Amps**
- Wire Range
 - (1) #8 - #24 sol/str
 - (2) 12 str
 - (2) 14 str
 - (1) 12 str and (1) 14 str
- .475" Centerline Spacing
- IP20 Touchproof Protection
- UL Recognized File No. XCFR2.E47811
- CSA Certified File No. LR19766
- **CE**
- RoHS Compliant

Catalog #	# of poles	Dimensions	
		A	B
0987 RZ TC 02	2	0.95	N/A
0987 RZ TC 03	3	1.43	0.48
0987 RZ TC 04	4	1.90	0.95
0987 RZ TC 05	5	2.38	1.43
0987 RZ TC 06	6	2.85	1.90
0987 RZ TC 07	7	3.33	2.38
0987 RZ TC 08	8	3.80	2.85
0987 RZ TC 09	9	4.28	3.33
0987 RZ TC 10	10	4.75	3.80
0987 RZ TC 11	11	5.23	4.28
0987 RZ TC 12	12	5.70	4.75

mm = dim X 25.4

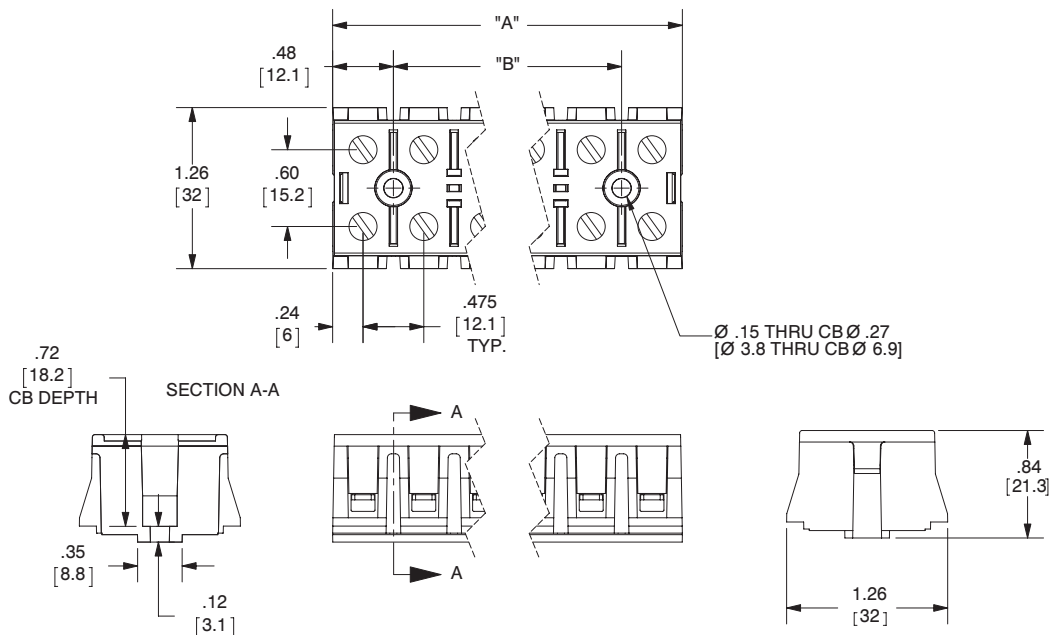

For electronic drawings or 2D/3D CAD data,
send request to drawings@marathonsp.com

Heavy Duty Terminal Blocks

985 GP Series - Deadfront Type

600 Volts AC/DC (UL/CSA)
630 Volts (CE)



985 GP 06

Specifications:

- Base, General Purpose Phenolic, 150°C
- Connector, Aluminum, Tin (Sn) Plated
- Screws, Steel, Tin (Sn) Plated
- Current Rating up to **85 Amps**
- Wire Range #4-#18 AWG Copper Wire
- Multiple Wire Combinations For Solid or Stranded Copper Wire Are:
 - (1) #4 AWG
 - (1) #6 AWG
 - (1 - 2) #8 AWG
 - (1 - 4) #10 AWG
 - (1 - 4) #12 AWG
 - (1 - 6) #14 AWG
 - (1 - 6) #16 AWG
 - (1 - 8) #18 AWG
- 5/8" (.625") Center-Line Spacing
- UL Recognized File No. XCFR2.E47811
- CSA Certified File No. LR19766
- CE
- RoHS Compliant

Catalog #	# of poles	Dimensions	
		A	B
985 GP 02	2	1.16	N/A
985 GP 03	3	1.78	0.63
985 GP 04	4	2.41	1.25
985 GP 05	5	3.03	1.88
985 GP 06	6	3.66	2.50
985 GP 07	7	4.28	3.13
985 GP 08	8	4.91	3.75
985 GP 09	9	5.53	4.38
985 GP 10	10	6.16	5.00
985 GP 11	11	6.78	5.63
985 GP 12	12	7.41	6.25

See page 34 for DIN Rail Adapter

mm = dim X 25.4

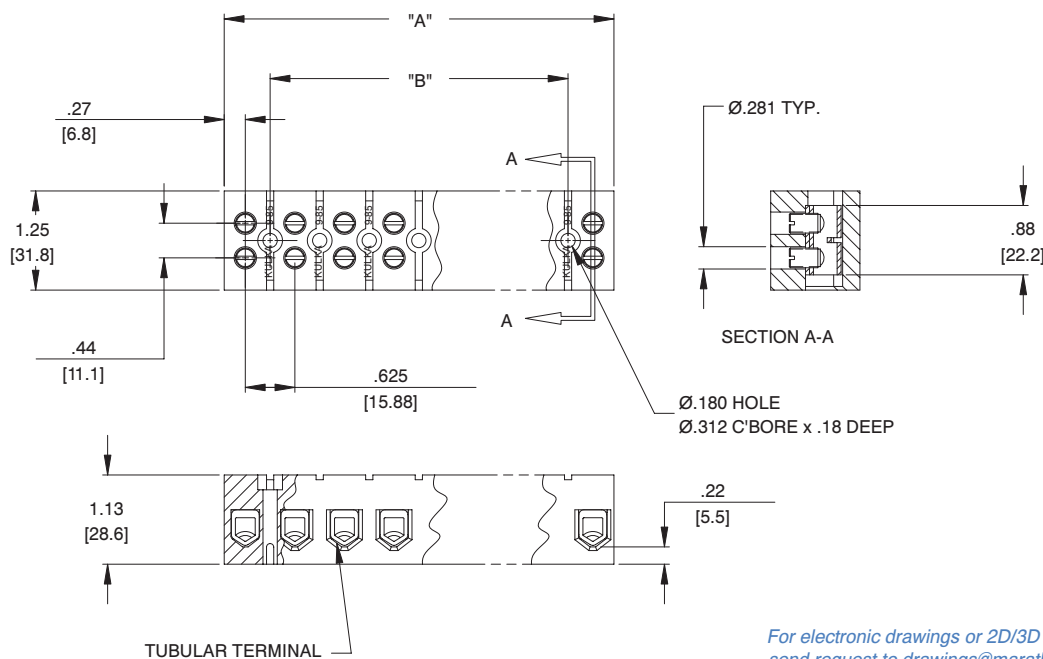

For electronic drawings or 2D/3D CAD data, send request to drawings@marathonsp.com

Heavy Duty Terminal Blocks

1500 Series

600 Volts AC/DC (UL/CSA)
1000 Volts (CE)



1508 STD



1508 SC

Specifications:

- Base, General Purpose Phenolic, 150°C
- Connector, Brass, Nickel Plated
- Phil-Slot Screws standard (slotted screws also available), Brass, Nickel Plated, 10-32
- Current rated up to 30 Amps with unprepared wire, #10-22 AWG Copper
- Current rated up to 75 Amps when wired with crimp type ring, spade or fork terminal
- 5/8" (.625") Line To Line Spacing
- UL Recognized File No. XCFR2.E62806
- CSA Certified File No. LR19766
- CE
- RoHS Compliant

# of Poles	Catalog #							Dimensions	
								A	B
2	1502 MCJ	1502 STD	1502 DJ	1502 DJSV	1502 ST	1502 SC	1502 H	2.00	1.62
4	1504 MCJ	1504 STD	1504 DJ	1504 DJSV	1504 ST	1504 SC	1504 H	3.25	2.88
6	1506 MCJ	1506 STD	1506 DJ	1506 DJSV	1506 ST	1506 SC	1506 H	4.50	4.12
8	1508 MCJ	1508 STD	1508 DJ	1508 DJSV	1508 ST	1508 SC	1508 H	5.75	5.38
12	1512 MCJ	1512 STD	1512 DJ	1512 DJSV	1512 ST	1512 SC	1512 H	8.25	7.88

See page 34 for DIN Rail Adapter

mm = dim X 25.4

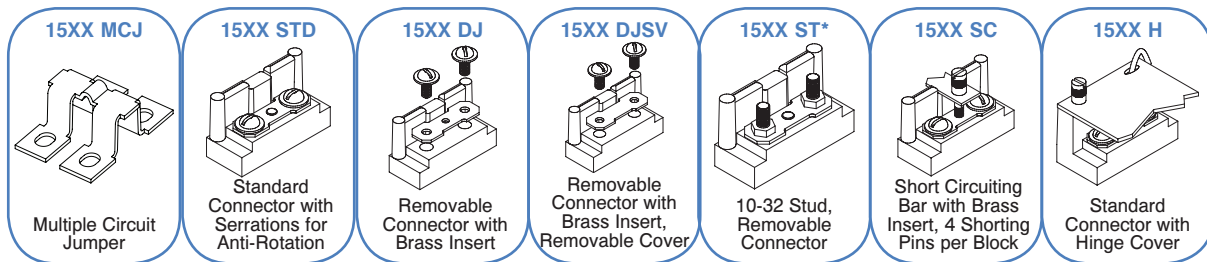

For electronic drawings or 2D/3D CAD data, send request to drawings@marathonsp.com

* STRC: 10-32 Stud with Riveted Connector

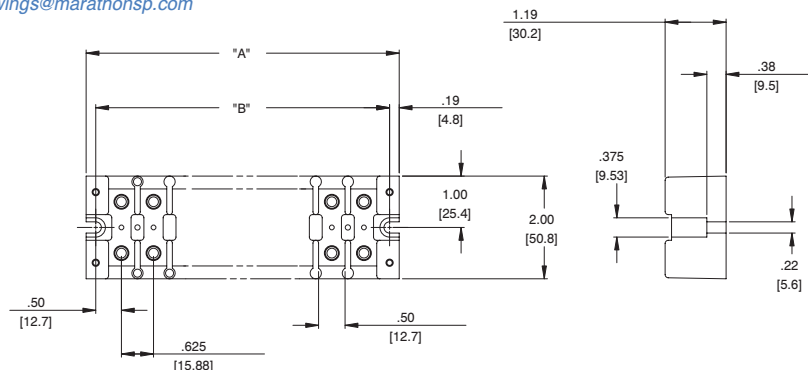

Heavy Duty Terminal Blocks

1600 Series

600 Volts AC/DC (UL/CSA)
1000 Volts (CE)

Specifications:

- Base, General Purpose Phenolic, 150°C
- Connector, Brass, Nickel Plated
- Phil-Slot Screws standard (slotted screws also available), Brass, Nickel Plated, 10-32
- Current rated up to 30 Amps with unprepared wire, #10-22 AWG Copper
- Current rated up to 75 Amps when wired with crimp type ring, spade or fork terminal
- 21/32" (.65625") Line To Line Spacing
- UL Recognized File No. XCFR2.E62806
- CSA Certified File No. LR19766
- CE
- RoHS Compliant



1604 H



1604 STD

# of Poles	Catalog #							Dimensions	
								A	B
2	1602 MCJ	1602 STD	1602 DJ	1602 DJSV	1602 ST	1602 SC	1602 H	2.44	1.78
4	1604 MCJ	1604 STD	1604 DJ	1604 DJSV	1604 ST	1604 SC	1604 H	3.75	3.09
6	1606 MCJ	1606 STD	1606 DJ	1606 DJSV	1606 ST	1606 SC	1606 H	5.06	4.41
8	1608 MCJ	1608 STD	1608 DJ	1608 DJSV	1608 ST	1608 SC	1608 H	6.38	5.72
12	1612 MCJ	1612 STD	1612 DJ	1612 DJSV	1612 ST	1612 SC	1612 H	9.00	8.34

See page 34 for DIN Rail Adapter

mm = dim X 25.4

<p>16XX MCJ</p> <p>Multiple Circuit Jumper</p>	<p>16XX STD</p> <p>Standard Connector with Serrations for Anti-Rotation</p>	<p>16XX DJ</p> <p>Removable Connector with Brass Insert</p>	<p>16XX DJSV</p> <p>Removable Connector with Brass Insert, Removable Cover</p>	<p>16XX ST*</p> <p>10-32 Stud, Removable Connector</p>	<p>16XX SC</p> <p>Short Circuiting Bar with Brass Insert, 4 Shorting Pins per Block</p>	<p>16XX H</p> <p>Standard Connector with Hinge Cover</p>
---	--	--	---	---	--	---

For electronic drawings or 2D/3D CAD data, send request to drawings@marathonsp.com

* STRC: 10-32 Stud with Riveted Connector

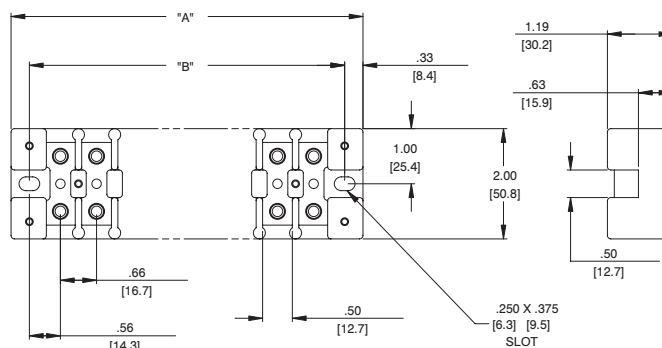

Heavy Duty Terminal Blocks

1700 Series

600 Volts AC/DC (UL/CSA)
1000 Volts (CE)

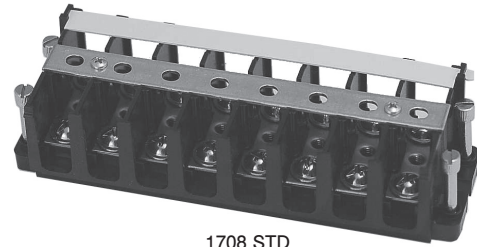

1708 STD



1708 SC

Specifications:

- Base, Thermoplastic, 125°C (UL RTI)
- Serrated Connectors, Brass, Nickel Plated
- Screws, Brass, Nickel Plated, 10-32
- Current rated up to 30 Amps with unprepared wire, #10-22 AWG Copper
- Current rated up to 75 Amps when wired with crimp type ring, spade or fork lugs
- 5/8" (.625") Line To Line Spacing
- UL Recognized File No. XCFR2.E62806
- CSA Certified File No. LR19766
- CE
- RoHS Compliant

Heavy Duty Terminal Blocks

# of Poles	Standard Terminal	Short Circuit Terminal	Dimensions		Clear Cover
			A	B	
2	1702 STD	1702 SC	2.00	1.64	CC 1702
3	1703 STD	1703 SC	2.63	2.26	CC 1703
4	1704 STD	1704 SC	3.25	2.89	CC 1704
5	1705 STD	1705 SC	3.88	3.51	CC 1705
6	1706 STD	1706 SC	4.50	4.14	CC 1706
7	1707 STD	1707 SC	5.13	4.76	CC 1707
8	1708 STD	1708 SC	5.75	5.39	CC 1708
9	1709 STD	1709 SC	6.38	6.01	CC 1709
10	1710 STD	1710 SC	7.00	6.64	CC 1710
11	1711 STD	1711 SC	7.63	7.26	CC 1711
12	1712 STD	1712 SC	8.25	7.89	CC 1712



1700 series optional cover

STD = Standard Terminal - Connector Plate, 2 Phil-Slot Screws, Center M/S

SC = Short Circuit Terminal (Pin to be torqued to 5 in-lbs)

CC = Cover - Clear PVC snap on cover, sized to fit and protect

mm = dim X 25.4

See page 34 for DIN Rail Adapter

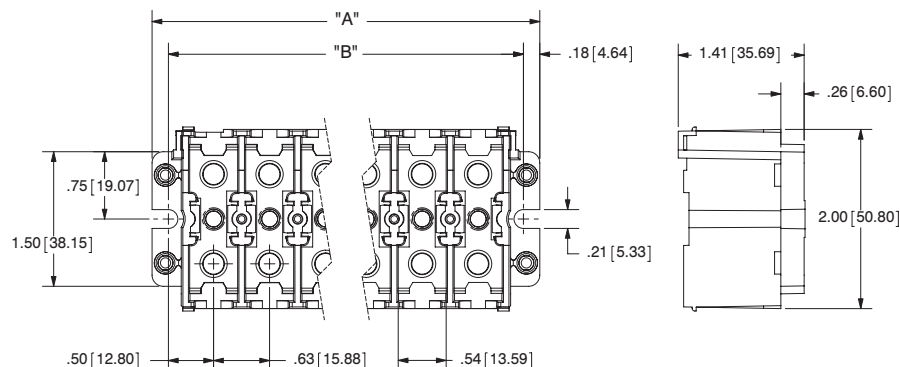

For electronic drawings or 2D/3D CAD data, send request to drawings@marathonsp.com

Datasheets available at marathonsp.com

Double Row Terminal Blocks

General Information:

Double Row Terminal Blocks are available in many line to line spacings. Open and closed back designs are available as shown in table below. Insulator bases are available in both phenolic and thermoplastic material. Modifications are also provided on most terminal blocks, including marking strips.

Ratings and Standards:

The voltage ratings of terminal blocks are based upon the minimum spacing between electrically conductive parts line to line through air and over surface and line to ground through air and over surface.

Class A:

Service, including deadfront switchboards, panel boards, service equipment and the like.

Class B:

Commercial appliances including business equipment, electronic data processing equipment and the like.

Class C:

Industrial, general

Class D:

Industrial, devices having limited ratings

Spacing Requirements (in inches):

	Voltage	Thru Air	Over Surface		Voltage	Thru Air	Over Surface
Class A	51-150	0.500	0.750	Class C	51-150	0.125	0.250
	151-300	0.750	1.250		151-300	0.250	0.375
	301-600	1.000	2.000		301-600	0.375	0.500
Class B	51-150	0.063	0.063	Class D*	51-300	0.063	0.125
	151-300	0.094	0.094		301-600	0.188	0.375
	301-600	0.375	0.500				

+These spacings are applicable to a terminal block for use only in or with industrial control equipment where the load on any single circuit of the terminal block does not exceed 15 Amp at 51-150 Volt, 10 Amp at 151-300 Volt, 5 Amp at 301-600 Volt, or the maximum amp rating, whichever is less.

Reference Chart:

Series	Catalog Page	Amps	Voltage Rating*			Base Material	Max Wire Size	Screw Size	Inches L to L	Number of Lines	Features
			Class B	Class C	Class D						
100/670A GP	73	20	300*	150	150*	Phenolic	#12	6-32	.375	1-36	Closed Back
200/671 GP	74	20	300*	300	600*	Phenolic	#12	6-32	.437	1-30	Closed Back
200HB	75	20	600*	600	600*	Phenolic	#12	6-32	.437	1-30	Closed Back/High Barrier
300/672 GP	76	30	600*	600	600*	Phenolic	#10	8-32	.562	1-24	Closed Back
400	77	30	600*	600	600*	Phenolic	#10	10-32	.687	1-12	Closed Back
410*	78	5	250	N/A	N/A	Phenolic	#18	2-56	.250	1-23	Open Back
600*	79	15	300	150	N/A	Phenolic	#12	5-40	.375	1-22	Open Back
600A/800A*	80	15	300	150	N/A	Phenolic	#12	6-32	.375	1-22	Open Back
601/801*	81	20	300	300	N/A	Phenolic	#12	6-32	.437	1-23	Open Back
602/802*	82	30	300	300	N/A	Phenolic	#12	8-32	.562	1-26	Open Back
603*	83	50	600	600	N/A	Phenolic	#10	10-32	.687	1-12	Open Back
604*	84	70	600	600	N/A	Phenolic	#4	12-32	.875	1-8	Open Back
605*	85	90	600	600	N/A	Phenolic	#2	1/4-28	1.125	1-6	Open Back
621 RZ	86	20	600*	600	600*	Thermoplastic	#12	6-32	.437	1-30	Closed Back/High Barrier
670A RZ	87	20	300	150	N/A	Thermoplastic	#12	6-32	.375	1-30	Closed Back
671 RZ	88	20	300	300*	600*	Thermoplastic	#12	6-32	.437	1-30	Closed Back
672 RZ	89	30	600*	600	600*	Thermoplastic	#10	8-32	.562	1-24	Closed Back

*Open back terminal blocks require an insulator strip to achieve voltage rating.

*Ratings pending UL investigation.

Double Row Terminal Blocks

100 Series Kulka® 670A GP Series 150 Volts AC/DC (Class C)



106 / 670A GP 06

Specifications:

- Base, General Purpose Phenolic, 150°C
- Closed Back Design
- Screws, #6-32 Binder Head, Phil-Slot, Steel
- Terminals, Plated Brass
- 1-36 Poles
- 3/8" Centers
- Wire Range With Wire Binding Screw #12 - #22 AWG – 20 Amps
- Wire Range With Sems Pressure Screw #18 - #22 AWG Stranded Copper Wire Only, 150 Volts 15 Amps
- UL Recognized File No. XCFR2.E62806
- CSA Certified File No. LR19766
- **CE**
- RoHS Compliant

MSP Catalog #	Kulka® Catalog #	# of poles	Dimensions	
			A	B
101	670A GP 01	1	1.03	0.75
102	670A GP 02	2	1.41	1.13
103	670A GP 03	3	1.78	1.50
104	670A GP 04	4	2.16	1.88
105	670A GP 05	5	2.53	2.25
106	670A GP 06	6	2.91	2.63
107	670A GP 07	7	3.28	3.00
108	670A GP 08	8	3.66	3.38
109	670A GP 09	9	4.03	3.75
110	670A GP 10	10	4.41	4.13
111	670A GP 11	11	4.78	4.50
112	670A GP 12	12	5.16	4.88
113	670A GP 13	13	5.53	5.25
114	670A GP 14	14	5.91	5.63
115	670A GP 15	15	6.28	6.00
116	670A GP 16	16	6.66	6.38
117	670A GP 17	17	7.03	6.75
118	670A GP 18	18	7.41	7.13
119	670A GP 19	19	7.78	7.50
120	670A GP 20	20	8.16	7.88
121	670A GP 21	21	8.53	8.25
122	670A GP 22	22	8.91	8.63
123	670A GP 23	23	9.28	9.00
124	670A GP 24	24	9.66	9.38
125	670A GP 25	25	10.03	9.75
126	670A GP 26	26	10.41	10.13
127	670A GP 27	27	10.78	10.50
128	670A GP 28	28	11.16	10.88
129	670A GP 29	29	11.53	11.25
130	670A GP 30	30	11.91	11.63
131	670A GP 31	31	12.28	12.00
132	670A GP 32	32	12.66	12.38
133	670A GP 33	33	13.03	12.75
134	670A GP 34	34	13.41	13.13
135	670A GP 35	35	13.78	13.50
136	670A GP 36	36	14.16	13.88

mm=dim X 25.4

Hardware Options:

(Hardware options may affect ratings - consult Customer Service)

CATALOG #	PRODUCT DESCRIPTION	PAGE REFERENCE
F1	KT19 Full Quick Connect (0° Flat)	See page 101
F2	KT20 Full Quick Connect (45° Bend)	See page 101
F3	KT21 Full Quick Connect (90° Bend)	See page 101
HF1	KT25 Half Quick Connect (0° Flat)	See page 101
HF2	KT26 Half Quick Connect (45° Bend)	See page 101
HF3	KT27 Half Quick Connect (90° Bend)	See page 101
S	ST Full Solder	See page 102
HS	3/4 ST Half Solder	See page 102
L	Y Feed Thru Solder (.312)	See page 102
LSL	YSY Feed Thru Solder (.500)	See page 102
LL 100	J 600 Line to Line Jumper	See page 103
	600RJ(S) Multiple Position Jumper	See page 103
SP	3865 SEMS Pressure Saddle Screw	See page 103
LWW	3000 Feed Thru Wire Wrap (.593)	Consult C/S
PSB	Phil-Slot Brass Screw	Consult C/S

Quick Connects: .020" x .187"

See pages 100-111 for terminal block accessories

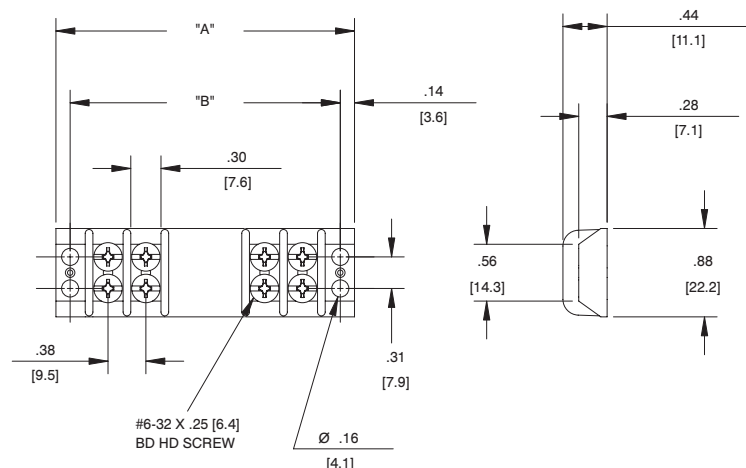

For electronic drawings or 2D/3D CAD data, send request to drawings@marathonsp.com

Double Row Terminal Blocks

200 Series Kulka® 671 GP Series 300 Volts AC/DC (Class C)



206 / 671 GP 06

Specifications:

- Base, General Purpose Phenolic, 150°C
- Closed Back Design
- Screws, #6-32 Binder Head, Phil-Slot, Steel
- Terminals, Plated Brass
- 1-30 Poles
- 7/16" Centers
- Wire Range With Wire Binding Screw #12 - #22 AWG – 20 Amps
- Wire Range With Sems Pressure Screw #12 - #22 AWG Stranded Copper Wire Only, 20 Amps
- UL Recognized File No. XCFR2.E62806
- CSA Certified File No. LR19766
- **CE**
- RoHS Compliant

MSP Catalog #	Kulka® Catalog #	# of poles	Dimensions	
			A	B
201	671 GP 01	1	1.19	0.88
202	671 GP 02	2	1.62	1.31
203	671 GP 03	3	2.06	1.75
204	671 GP 04	4	2.50	2.19
205	671 GP 05	5	2.94	2.63
206	671 GP 06	6	3.37	3.06
207	671 GP 07	7	3.81	3.50
208	671 GP 08	8	4.25	3.94
209	671 GP 09	9	4.69	4.38
210	671 GP 10	10	5.12	4.81
211	671 GP 11	11	5.56	5.25
212	671 GP 12	12	6.00	5.69
213	671 GP 13	13	6.44	6.13
214	671 GP 14	14	6.87	6.56
215	671 GP 15	15	7.31	7.00
216	671 GP 16	16	7.75	7.44
217	671 GP 17	17	8.19	7.88
218	671 GP 18	18	8.62	8.31
219	671 GP 19	19	9.06	8.75
220	671 GP 20	20	9.50	9.19
221	671 GP 21	21	9.94	9.63
222	671 GP 22	22	10.37	10.06
223	671 GP 23	23	10.81	10.50
224	671 GP 24	24	11.25	10.94
225	671 GP 25	25	11.69	11.38
226	671 GP 26	26	12.12	11.81
227	671 GP 27	27	12.56	12.25
228	671 GP 28	28	13.00	12.69
229	671 GP 29	29	13.44	13.13
230	671 GP 30	30	13.87	13.56

mm=dim X 25.4

For electronic drawings or 2D/3D CAD data, send request to drawings@marathonsp.com

Hardware Options:

(Hardware options may affect ratings - consult Customer Service)

CATALOG #	PRODUCT DESCRIPTION	PAGE REFERENCE
F1	KT37 Full Quick Connect (0° Flat)	See page 101
F2	KT38 Full Quick Connect (45° Bend)	See page 101
F3	KT39 Full Quick Connect (90° Bend)	See page 101
HF1	KT43 Half Quick Connect (0° Flat)	See page 101
HF2	KT44 Half Quick Connect (45° Bend)	See page 101
HF3	KT45 Half Quick Connect (90° Bend)	See page 101
S	ST Full Solder	See page 102
HS	3/4 ST Half Solder	See page 102
L	Y Feed Thru Solder (.437)	See page 102
LSL	YSY Feed Thru Solder (.625)	See page 102
LL 200	J 601 Line to Line Jumper	See page 103
	601RJ(S) Multiple Position Jumper	See page 103
SP	3765 SEMS Pressure Saddle Screw	See page 103
SPSE	3767 SEMS Pressure Saddle Screw with External Tooth Lock Washer	Consult C/S
LWW	4000 Feed Thru Wire Wrap (.640)	Consult C/S
PSB	Phil-Slot Brass Screw	Consult C/S

Quick Connects: .032" x .250"

See pages 100-111 for terminal block accessories

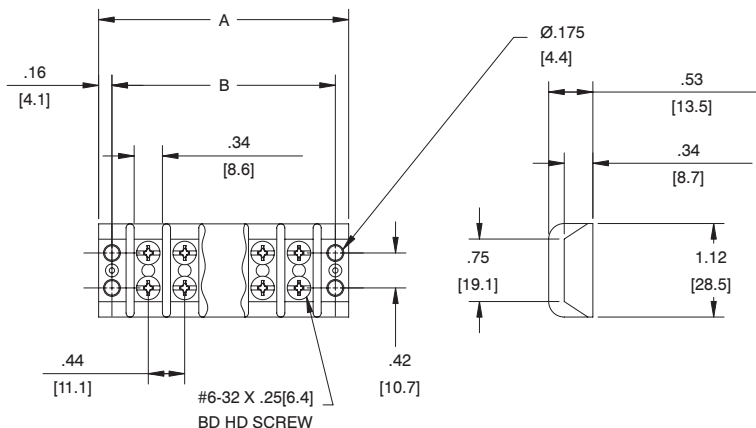

Double Row Terminal Blocks

200HB Series (High Barrier)

600 Volts AC/DC (Class C)

(See page 86 for Thermoplastic Version 621 RZ)



206HB

Specifications:

- Base, General Purpose Phenolic, 150°C
- Closed Back Design
- Screws, #6-32 Binder Head, Phil-Slot, Steel
- Terminals, Plated Brass
- 1-30 Poles
- 7/16" Centers
- Wire Range With Wire Binding Screw #12 - #22 AWG – 20 Amps
- Wire Range With Sems Pressure Screw #12 - #22 AWG Stranded Copper Wire Only, 20 Amps
- UL Recognized File No. XCFR2.E62806
- CSA Certified File No. LR19766
- **CE**
- RoHS Compliant

MSP Catalog #	# of poles	Dimensions	
		A	B
201HB	1	1.19	0.88
202HB	2	1.62	1.31
203HB	3	2.06	1.75
204HB	4	2.50	2.19
205HB	5	2.94	2.63
206HB	6	3.37	3.06
207HB	7	3.81	3.50
208HB	8	4.25	3.94
209HB	9	4.69	4.38
210HB	10	5.12	4.81
211HB	11	5.56	5.25
212HB	12	6.00	5.69
213HB	13	6.44	6.13
214HB	14	6.87	6.56
215HB	15	7.31	7.00
216HB	16	7.75	7.44
217HB	17	8.19	7.88
218HB	18	8.62	8.31
219HB	19	9.06	8.75
220HB	20	9.50	9.19
221HB	21	9.94	9.63
222HB	22	10.37	10.06
223HB	23	10.81	10.50
224HB	24	11.25	10.94
225HB	25	11.69	11.38
226HB	26	12.12	11.81
227HB	27	12.56	12.25
228HB	28	13.00	12.69
229HB	29	13.44	13.13
230HB	30	13.87	13.56

mm=dim X 25.4

For electronic drawings or 2D/3D CAD data, send request to drawings@marathonsp.com

Hardware Options:

(Hardware options may affect ratings - consult Customer Service)

CATALOG #	PRODUCT DESCRIPTION	PAGE REFERENCE
F1	Full Quick Connect (0° Flat)	See page 101
F2	Full Quick Connect (45° Bend)	See page 101
F3	Full Quick Connect (90° Bend)	See page 101
HF1	Half Quick Connect (0° Flat)	See page 101
HF2	Half Quick Connect (45° Bend)	See page 101
HF3	Half Quick Connect (90° Bend)	See page 101
S	Full Solder	See page 102
HS	Half Solder	See page 102
L Y	Feed Thru Solder (.437)	See page 102
LSL YSY	Feed Thru Solder (.625)	See page 102
LL 200HB	Line to Line Jumper	See page 103
601RJ(S)	Multiple Position Jumper	See page 103
SP	SEMS Pressure Saddle Screw	See page 103
SPSE	SEMS Pressure Saddle Screw with External Tooth Lock Washer	Consult C/S
LWW	Feed Thru Wire Wrap (.640)	Consult C/S
PSB	Phil-Slot Brass Screw	Consult C/S

Quick Connects: .032" x .250"

See pages 100-111 for terminal block accessories

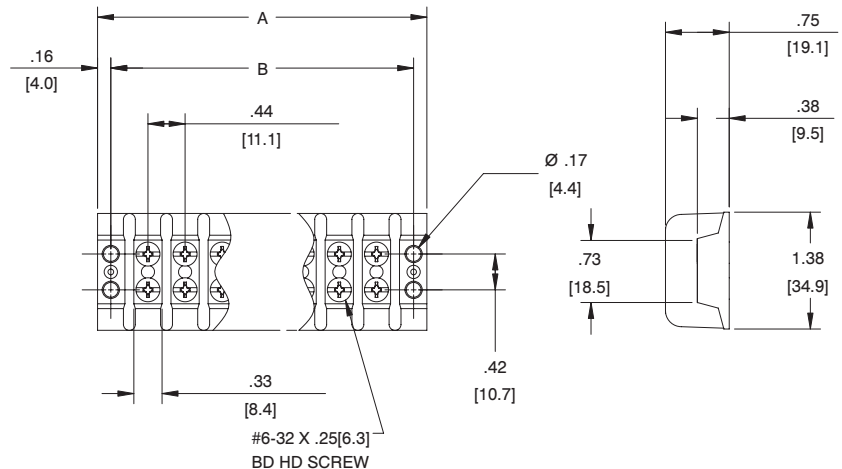

Double Row Terminal Blocks

300 Series Kulka® 672 GP Series 600 Volts AC/DC (Class C)



306 / 672 GP 06

Specifications:

- Base, General Purpose Phenolic, 150°C
- Closed Back Design
- Screws, #8-32 Binder Head, Phil-Slot, Steel
- Terminals, Plated Brass
- 1-24 Poles
- 9/16" Centers
- Wire Range With Wire Binding Screw #10 - #14 AWG – 30 Amps
- Wire Range With Sems Pressure Screw #10 - #22 AWG Stranded Copper Wire Only, 30 Amps
- Will Accommodate Lugs for Wire Sizes #10 - #16 AWG, 30 Amps
- UL Recognized File No. XCFR2.E62806
- CSA Certified File No. LR19766
- **CE**
- RoHS Compliant

MSP Catalog #	Kulka® Catalog #	# of poles	Dimensions	
			A	B
301	672 GP 01	1	1.54	1.13
302	672 GP 02	2	2.10	1.69
303	672 GP 03	3	2.66	2.25
304	672 GP 04	4	3.22	2.81
305	672 GP 05	5	3.79	3.38
306	672 GP 06	6	4.35	3.94
307	672 GP 07	7	4.91	4.50
308	672 GP 08	8	5.47	5.06
309	672 GP 09	9	6.04	5.63
310	672 GP 10	10	6.60	6.19
311	672 GP 11	11	7.16	6.75
312	672 GP 12	12	7.72	7.31
313	672 GP 13	13	8.29	7.88
314	672 GP 14	14	8.85	8.44
315	672 GP 15	15	9.41	9.00
316	672 GP 16	16	9.97	9.56
317	672 GP 17	17	10.54	10.13
318	672 GP 18	18	11.10	10.69
319	672 GP 19	19	11.66	11.25
320	672 GP 20	20	12.22	11.81
321	672 GP 21	21	12.79	12.38
322	672 GP 22	22	13.35	12.94
323	672 GP 23	23	13.91	13.50
324	672 GP 24	24	14.47	14.06

mm=dim X 25.4

For electronic drawings or 2D/3D CAD data, send request to drawings@marathonsp.com

Hardware Options:

(Hardware options may affect ratings - consult Customer Service)

CATALOG #	PRODUCT DESCRIPTION	PAGE REFERENCE
F1	KT55 Full Quick Connect (0° Flat)	See page 101
F2	KT56 Full Quick Connect (45° Bend)	See page 101
F3	KT57 Full Quick Connect (90° Bend)	See page 101
HF1	KT61 Half Quick Connect (0° Flat)	See page 101
HF2	KT62 Half Quick Connect (45° Bend)	See page 101
HF3	KT63 Half Quick Connect (90° Bend)	See page 101
S	ST Full Solder	See page 102
HS	3/4 ST Half Solder	See page 102
L	Y Feed Thru Solder (.437)	See page 102
LSL	YSY Feed Thru Solder (.625)	See page 102
LL 300	J 602 Line to Line Jumper	See page 103
SP	3786 SEMS Pressure Saddle Screw	See page 103
SPSE	SEMS Pressure Saddle Screw with External Tooth Lock Washer	Consult C/S
LWW	Feed Thru Wire Wrap (1.00)	Consult C/S
PSB	Phil-Slot Brass Screw	Consult C/S

Quick Connects: .032" x .250"

See pages 100-111 for terminal block accessories

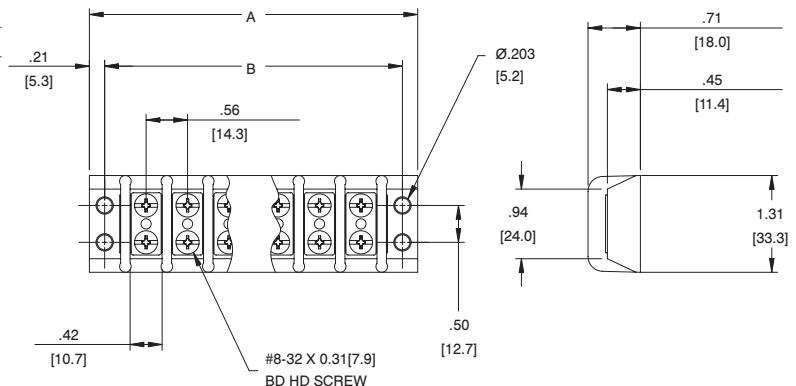

Double Row Terminal Blocks

400 Series

600 Volts AC/DC (Class C)

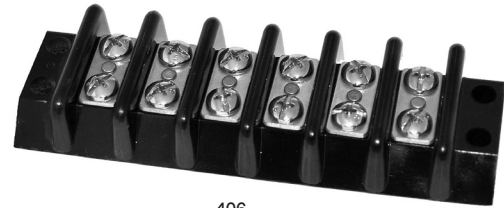

406

Specifications:

- Base, General Purpose Phenolic, 150°C
- Closed Back Design
- Screws, #10-32 Binder Head, Phil-Slot, Steel
- Terminals, Plated Brass
- 1-12 Poles
- 11/16" Centers
- Wire Range With Wire Binding Screw #10 - #22 AWG – 30 Amps
- Wire Range With Sems Pressure Screw #10 - #22 AWG Stranded Copper Wire Only, 30 Amps
- Will Accommodate Lugs for Wire Sizes #6 - #16 AWG, 65 Amps
- UL Recognized File No. XCFR2.E62806
- CSA Certified File No. LR19766
- **CE**
- RoHS Compliant

MSP Catalog #	# of poles	Dimensions	
		A	B
401	1	1.81	1.38
402	2	2.50	2.06
403	3	3.19	2.75
404	4	3.88	3.44
405	5	4.56	4.12
406	6	5.25	4.81
407	7	5.94	5.50
408	8	6.62	6.19
409	9	7.31	6.88
410	10	8.00	7.56
411	11	8.68	8.25
412	12	9.37	8.94

mm=dim X 25.4

For electronic drawings or 2D/3D CAD data, send request to drawings@marathonsp.com

Hardware Options:

(Hardware options may affect ratings - consult Customer Service)

CATALOG #	PRODUCT DESCRIPTION	PAGE REFERENCE
F1	Full Quick Connect (0° Flat)	See page 101
F2	Full Quick Connect (45° Bend)	See page 101
F3	Full Quick Connect (90° Bend)	See page 101
HF1	Half Quick Connect (0° Flat)	See page 101
HF2	Half Quick Connect (45° Bend)	See page 101
HF3	Half Quick Connect (90° Bend)	See page 101
LL 400	Line to Line Jumper	See page 103
SPSE	SEMS Pressure Saddle Screw	Consult C/S
PSB	Phil-Slot Brass Screw	Consult C/S

Quick Connects: .032" x .250"

See pages 100-111 for terminal block accessories

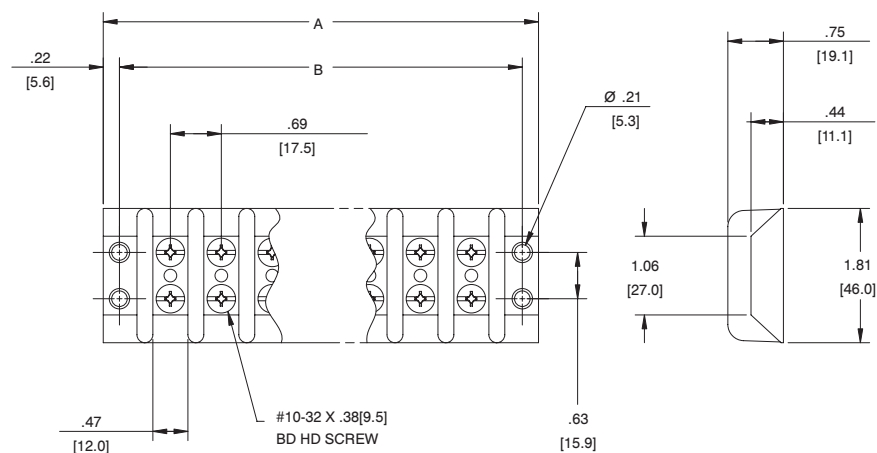

Double Row Terminal Blocks

Kulka® 410 GP Series

250 Volts AC/DC (Class B)

Classes C/D do not apply



410 GP 06 PSB

Specifications:

- Base, Phenolic, 150°C
- Open Back Design (Insulator Strip required for Voltage Rating - see page 108)
- JJ (GDI-30F) Material Available
- Screws, #2-56 x 7/32 Binder Head, Phil-Slot, Brass
- Terminals, Plated Brass
- 1-23 Poles
- 1/4" Centers
- Wire Range With Wire Binding Screw
#18 - #20 AWG – 5 Amps
- UL Recognized File No. XCFR2.E47811
- CSA Certified File No. LR19766
- **CE**
- RoHS Compliant

Double Row Terminal Blocks

Kulka® Catalog #	# of poles	Dimensions	
		A	B
410 GP 01 PSB	1	1.19	0.88
410 GP 02 PSB	2	1.62	1.31
410 GP 03 PSB	3	2.06	1.75
410 GP 04 PSB	4	2.50	2.19
410 GP 05 PSB	5	2.94	2.63
410 GP 06 PSB	6	3.37	3.06
410 GP 07 PSB	7	3.81	3.50
410 GP 08 PSB	8	4.25	3.94
410 GP 09 PSB	9	4.69	4.38
410 GP 10 PSB	10	5.12	4.81
410 GP 11 PSB	11	5.56	5.25
410 GP 12 PSB	12	6.00	5.69
410 GP 13 PSB	13	6.44	6.13
410 GP 14 PSB	14	6.87	6.56
410 GP 15 PSB	15	7.31	7.00
410 GP 16 PSB	16	7.75	7.44
410 GP 17 PSB	17	8.19	7.88
410 GP 18 PSB	18	8.62	8.31
410 GP 19 PSB	19	9.06	8.75
410 GP 20 PSB	20	9.50	9.19
410 GP 21 PSB	21	9.94	9.63
410 GP 22 PSB	22	10.37	10.06
410 GP 23 PSB	23	10.81	10.50

mm=dim X 25.4

For electronic drawings or 2D/3D CAD data, send request to drawings@marathonsp.com

Hardware Options:

(Hardware options may affect ratings - consult Customer Service)

CATALOG # MSP KULKA	PRODUCT DESCRIPTION	PAGE REFERENCE
ST	Full Solder	See page 102
3/4 ST	Half Solder	See page 102
Y	Feed Thru Solder (.437)	See page 102
J 410	Line to Line Jumper	See page 103
1921	Printed Circuit Pin (.109)	Consult C/S

Quick Connects: .020" x .110"

See pages 100-111 for terminal block accessories

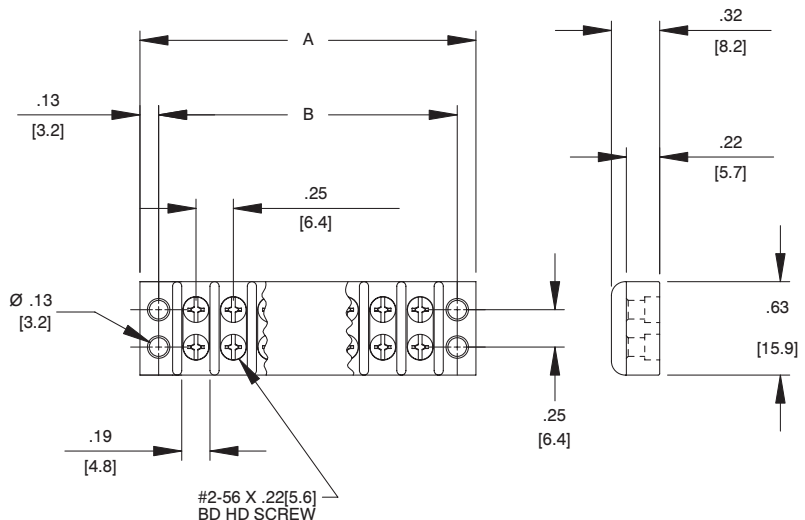

Double Row Terminal Blocks

Kulka® 600 GP Series

300 Volts AC/DC (Class B)

150 Volts AC/DC (Class C)

Class D does not apply



600 GP 07 PSB

Specifications:

- Base, Phenolic, 150°C
- Open Back Design (Insulator Strip required for Voltage Rating - see page 108)
- JJ (GDI-30F) Material Available
- Screws, #5-40 Binder Head, Phil-Slot, Brass
- Terminals, Plated Brass
- 1-22 Poles
- 3/8" Centers
- Wire Range With Wire Binding Screw
#12 - #22 AWG – 15 Amps
- UL Recognized File No. XCFR2.E47811
- CSA Certified File No. LR19766
- **CE**
- RoHS Compliant

Kulka® Catalog #	# of poles	Dimensions	
		A	B
600 GP 01 PSB	1	1.03	0.75
600 GP 02 PSB	2	1.41	1.13
600 GP 03 PSB	3	1.78	1.50
600 GP 04 PSB	4	2.16	1.88
600 GP 05 PSB	5	2.53	2.25
600 GP 06 PSB	6	2.91	2.63
600 GP 07 PSB	7	3.28	3.00
600 GP 08 PSB	8	3.66	3.38
600 GP 09 PSB	9	4.03	3.75
600 GP 10 PSB	10	4.41	4.13
600 GP 11 PSB	11	4.78	4.50
600 GP 12 PSB	12	5.16	4.88
600 GP 13 PSB	13	5.53	5.25
600 GP 14 PSB	14	5.91	5.63
600 GP 15 PSB	15	6.28	6.00
600 GP 16 PSB	16	6.66	6.38
600 GP 17 PSB	17	7.03	6.75
600 GP 18 PSB	18	7.41	7.13
600 GP 19 PSB	19	7.78	7.50
600 GP 20 PSB	20	8.16	7.88
600 GP 21 PSB	21	8.53	8.25
600 GP 22 PSB	22	8.91	8.63

mm=dim X 25.4

For electronic drawings or 2D/3D CAD data,
send request to drawings@marathonsp.com

Hardware Options:

(Hardware options may affect ratings - consult Customer Service)

CATALOG # MSP	KULKA	PRODUCT DESCRIPTION	PAGE REFERENCE
	KT19	Full Quick Connect (0° Flat)	See Page 101
	KT20	Full Quick Connect (45° Bend)	See Page 101
	KT21	Full Quick Connect (90° Bend)	See Page 101
	KT25	Half Quick Connect (0° Flat)	See Page 101
	KT26	Half Quick Connect (45° Bend)	See Page 101
	KT27	Half Quick Connect (90° Bend)	See Page 101
	ST	Full Solder	See Page 102
	3/4 ST	Half Solder	See Page 102
	Y	Feed Thru Solder (.312)	See Page 102
	YSY	Feed Thru Solder (.500)	See Page 102
	Z	Lug Over the Side (.625)	See Page 102
	J 600	Line to Line Jumper	See Page 103
	600 RJ(S)	Multiple Position Jumper	See Page 103
	2004	Feed Thru Solder	See Page 105

Quick Connects: .020" x .187"

See pages 100-111 for terminal block accessories

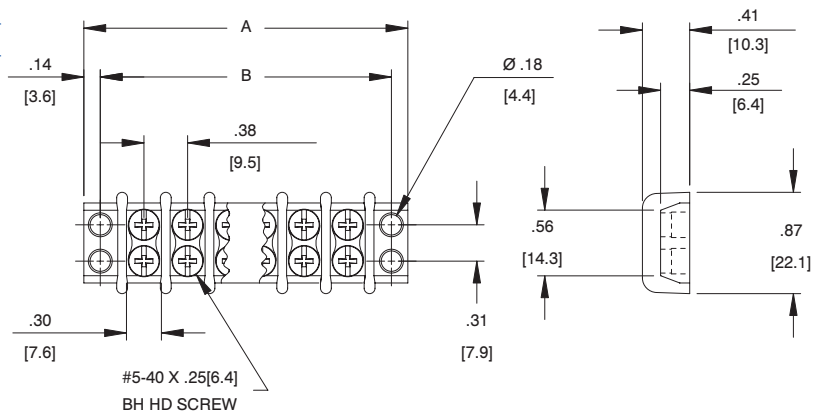

Double Row Terminal Blocks

Kulka® 600A/800A GP Series

300 Volts AC/DC (Class B)

150 Volts AC/DC (Class C)

Class D does not apply



600A GP 06

Specifications:

- Base, Phenolic, 150°C
- Open Back Design (Insulator Strip required for Voltage Rating - see page 108)
- JJ (GDI-30F) Material Available
- Screws, #6-32 Binder Head, Phil-Slot, Steel
- Terminals, Plated Brass
- 1-22 Poles
- 3/8" Centers
- Wire Range With Wire Binding Screw
#12 - #22 AWG – 15 Amps
- 800A Series (Riveted KT's) - see page 98
- UL Recognized File No. XCFR2.E47811
- CSA Certified File No. LR19766
- **CE**
- RoHS Compliant

Double Row Terminal Blocks

Kulka® Catalog #	# of poles	Dimensions	
		A	B
600A GP 01	1	1.03	0.75
600A GP 02	2	1.41	1.13
600A GP 03	3	1.78	1.50
600A GP 04	4	2.16	1.88
600A GP 05	5	2.53	2.25
600A GP 06	6	2.91	2.63
600A GP 07	7	3.28	3.00
600A GP 08	8	3.66	3.38
600A GP 09	9	4.03	3.75
600A GP 10	10	4.41	4.13
600A GP 11	11	4.78	4.50
600A GP 12	12	5.16	4.88
600A GP 13	13	5.53	5.25
600A GP 14	14	5.91	5.63
600A GP 15	15	6.28	6.00
600A GP 16	16	6.66	6.38
600A GP 17	17	7.03	6.75
600A GP 18	18	7.41	7.13
600A GP 19	19	7.78	7.50
600A GP 20	20	8.16	7.88
600A GP 21	21	8.53	8.25
600A GP 22	22	8.91	8.63

mm=dim X 25.4

For electronic drawings or 2D/3D CAD data,
send request to drawings@marathonsp.com

Hardware Options:

(Hardware options may affect ratings - consult Customer Service)

CATALOG #	PRODUCT DESCRIPTION	PAGE REFERENCE
MSP		
KULKA		
KT19	Full Quick Connect (0° Flat)	See Page 101
KT20	Full Quick Connect (45° Bend)	See Page 101
KT21	Full Quick Connect (90° Bend)	See Page 101
KT25	Half Quick Connect (0° Flat)	See Page 101
KT26	Half Quick Connect (45° Bend)	See Page 101
KT27	Half Quick Connect (90° Bend)	See Page 101
ST	Full Solder	See Page 102
3/4 ST	Half Solder	See Page 102
Y	Feed Thru Solder (.312)	See Page 102
YSY	Feed Thru Solder (.500)	See Page 102
Z	Lug Over the Side (.625)	See Page 102
J 600	Line to Line Jumper	See Page 103
600 RJ(S)	Multiple Position Jumper	See Page 103
3860	Wire Clamp Screw, Brass	See Page 103
3865	Wire Clamp Screw	See Page 103
2002	Stud	See Page 105
PSB	Phil-Slot Brass Screw	Consult C/S

Quick Connects: .020" x .187"

See pages 100-111 for terminal block accessories

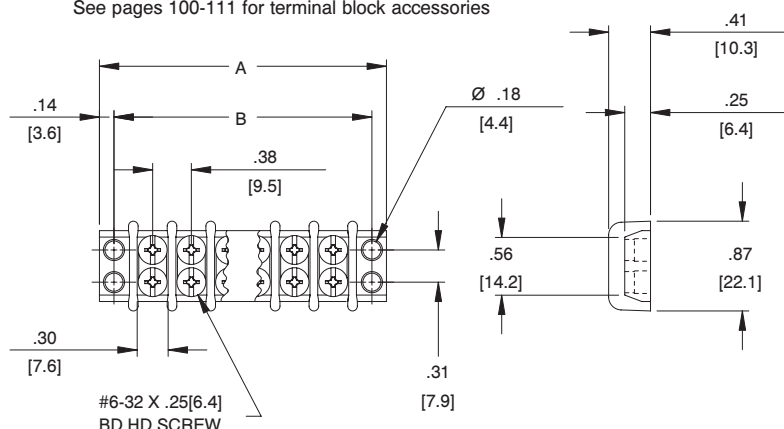

Double Row Terminal Blocks

Kulka® 601/801 GP Series

300 Volts AC/DC (Classes B/C)

Class D does not apply



601 GP 06

Specifications:

- Base, General Purpose Phenolic, 150°C
- Open Back Design (Insulator Strip required for Voltage Rating - see page 108)
- JJ (GDI-30F) Material Available
- Screws, #6-32 Binder Head, Phil-Slot, Steel
- Terminals, Plated Brass
- 1-23 Poles
- 7/16" Centers
- Wire Range With Wire Binding Screw #12 - #22 AWG – 20 Amps
- 801 Series (Riveted KT's) - see page 98
- UL Recognized File No. XCFR2.E47811
- CSA Certified File No. LR19766
- **CE**
- RoHS Compliant

Kulka® Catalog #	# of poles	Dimensions	
		A	B
601 GP 01	1	1.19	0.88
601 GP 02	2	1.62	1.31
601 GP 03	3	2.06	1.75
601 GP 04	4	2.50	2.19
601 GP 05	5	2.94	2.63
601 GP 06	6	3.37	3.06
601 GP 07	7	3.81	3.50
601 GP 08	8	4.25	3.94
601 GP 09	9	4.69	4.38
601 GP 10	10	5.12	4.81
601 GP 11	11	5.56	5.25
601 GP 12	12	6.00	5.69
601 GP 13	13	6.44	6.13
601 GP 14	14	6.87	6.56
601 GP 15	15	7.31	7.00
601 GP 16	16	7.75	7.44
601 GP 17	17	8.19	7.88
601 GP 18	18	8.62	8.31
601 GP 19	19	9.06	8.75
601 GP 20	20	9.50	9.19
601 GP 21	21	9.94	9.63
601 GP 22	22	10.37	10.06
601 GP 23	23	10.81	10.50

mm=dim X 25.4

For electronic drawings or 2D/3D CAD data,
send request to drawings@marathonsp.com

Hardware Options:

(Hardware options may affect ratings - consult Customer Service)

CATALOG #	PRODUCT DESCRIPTION	PAGE REFERENCE
MSP		
KULKA		
KT37	Full Quick Connect (0° Flat)	See Page 101
KT38	Full Quick Connect (45° Bend)	See Page 101
KT39	Full Quick Connect (90° Bend)	See Page 101
KT43	Half Quick Connect (0° Flat)	See Page 101
KT44	Half Quick Connect (45° Bend)	See Page 101
KT45	Half Quick Connect (90° Bend)	See Page 101
ST	Full Solder	See Page 102
3/4 ST	Half Solder	See Page 102
Y	Feed Thru Solder (.422)	See Page 102
YSY	Feed Thru Solder (.687)	See Page 102
J 601	Line to Line Jumper	See Page 103
601 RJ(S)	Multiple Position Jumper	See Page 103
3765	Wire Clamp Screw	See Page 103
3760	Wire Clamp Screw	See Page 103
2102	Stud	See Page 105
2104	Feed Thru Solder	See Page 105
2108	Individual Screw Terminals	See Page 105
PSB	Phil-Slot Brass Screw	Consult C/S

Quick Connects: .032" x .250"

See pages 100-111 for terminal block accessories

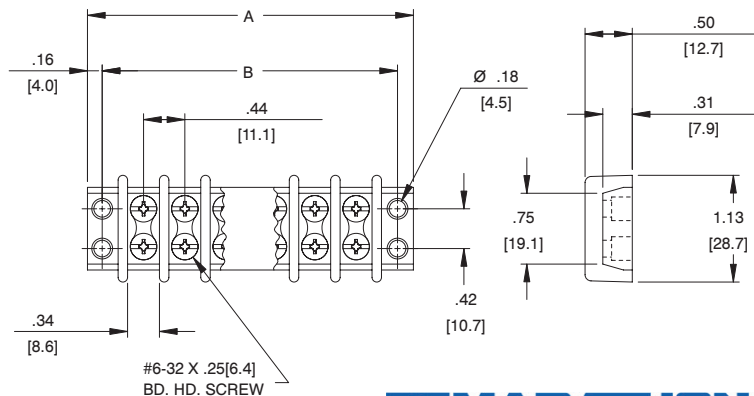

Double Row Terminal Blocks

Kulka® 602/802 GP Series

300 Volts AC/DC (Classes B/C)

Class D does not apply



602 GP 06

Specifications:

- Base, General Purpose Phenolic, 150°C
- Open Back Design (Insulator Strip required for Voltage Rating - see page 108)
- JJ (GDI-30F) Material Available
- Screws, #8-32 Binder Head, Phil-Slot, Steel
- Terminals, Plated Brass
- 1-26 Poles
- 9/16" Centers
- Wire Range With Wire Binding Screw #10 - #18 AWG – 30 Amps
- 802 Series (Riveted KT's) - see page 98
- UL Recognized File No. XCFR2.E47811
- CSA Certified File No. LR19766
- CE
- RoHS Compliant

Double Row Terminal Blocks

Kulka® Catalog #	# of poles	Dimensions	
		A	B
602 GP 01	1	1.54	1.13
602 GP 02	2	2.10	1.69
602 GP 03	3	2.66	2.25
602 GP 04	4	3.22	2.81
602 GP 05	5	3.79	3.38
602 GP 06	6	4.35	3.94
602 GP 07	7	4.91	4.50
602 GP 08	8	5.47	5.06
602 GP 09	9	6.04	5.63
602 GP 10	10	6.60	6.19
602 GP 11	11	7.16	6.75
602 GP 12	12	7.72	7.31
602 GP 13	13	8.29	7.88
602 GP 14	14	8.85	8.44
602 GP 15	15	9.41	9.00
602 GP 16	16	9.97	9.56
602 GP 17	17	10.54	10.13
602 GP 18	18	11.10	10.69
602 GP 19	19	11.66	11.25
602 GP 20	20	12.22	11.81
602 GP 21	21	12.79	12.38
602 GP 22	22	13.35	12.94
602 GP 23	23	13.91	13.50
602 GP 24	24	14.47	14.06
602 GP 25	25	15.04	14.63
602 GP 26	26	15.60	15.19

mm=dim X 25.4

For electronic drawings or 2D/3D CAD data,
send request to drawings@marathonsp.com

Hardware Options:

(Hardware options may affect ratings - consult Customer Service)

CATALOG # MSP KULKA	PRODUCT DESCRIPTION	PAGE REFERENCE
KT55	Full Quick Connect (0° Flat)	See Page 101
KT56	Full Quick Connect (45° Bend)	See Page 101
KT57	Full Quick Connect (90° Bend)	See Page 101
KT61	Half Quick Connect (0° Flat)	See Page 101
KT62	Half Quick Connect (45° Bend)	See Page 101
KT63	Half Quick Connect (90° Bend)	See Page 101
ST	Full Solder	See Page 102
3/4 ST	Half Solder	See Page 102
Y	Feed Thru Solder (.500)	See Page 102
YSY	Feed Thru Solder (.672)	See Page 102
Z	Lug over the Side (.609)	See Page 102
J 602	Line to Line Jumper	See Page 103
3786	Wire Clamp Screw	See Page 103
2202	Stud	See Page 105
PSB	Phil-Slot Brass Screw	Consult C/S

Quick Connects: .032" x .250"

See pages 100-111 for terminal block accessories

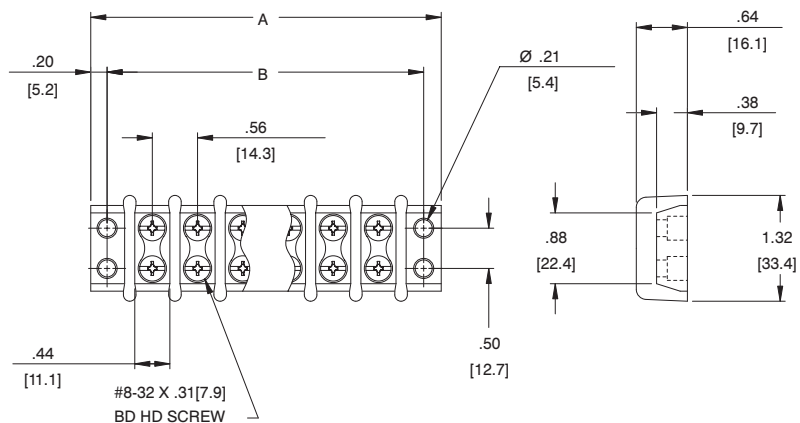

Double Row Terminal Blocks

Kulka® 603 GP Series

600 Volts AC/DC (Classes B/C)

Class D does not apply



603 GP 06

Specifications:

- Base, General Purpose Phenolic, 150°C
- Open Back Design (Insulator Strip required for Voltage Rating - see page 108)
- JJ (GDI-30F) Material Available
- Screws, #10-32 Binder Head, Phil-Slot, Steel
- Terminals, Plated Brass
- 1-12 Poles
- 11/16" Centers
- Wire Range With Wire Binding Screw #10 - #16 AWG – 30 Amps
- 50 Amps with Listed Wire Lugs
- UL Recognized File No. XCFR2.E47811
- CSA Certified File No. LR19766
- **CE**
- RoHS Compliant

Kulka® Catalog #	# of poles	Dimensions	
		A	B
603 GP 01	1	1.81	1.38
603 GP 02	2	2.50	2.06
603 GP 03	3	3.19	2.75
603 GP 04	4	3.88	3.44
603 GP 05	5	4.56	4.12
603 GP 06	6	5.25	4.81
603 GP 07	7	5.94	5.50
603 GP 08	8	6.62	6.19
603 GP 09	9	7.31	6.88
603 GP 10	10	8.00	7.56
603 GP 11	11	8.68	8.25
603 GP 12	12	9.37	8.94

mm=dim X 25.4

For electronic drawings or 2D/3D CAD data,
send request to drawings@marathonsp.com

Hardware Options:

(Hardware options may affect ratings - consult Customer Service)

CATALOG #	PRODUCT DESCRIPTION	PAGE REFERENCE
MSP	KULKA	
KT67	Full Quick Connect (0° Flat)	See Page 101
KT68	Full Quick Connect (45° Bend)	See Page 101
KT69	Full Quick Connect (90° Bend)	See Page 101
KT64	Half Quick Connect (0° Flat)	See Page 101
KT65	Half Quick Connect (45° Bend)	See Page 101
KT66	Half Quick Connect (90° Bend)	See Page 101
Y	Feed Thru Solder (.60)	See Page 102
J 603	Line to Line Jumper	See Page 103
2302	Stud	See Page 105
PSB	Phil-Slot Brass Screw	Consult C/S

Quick Connects: .032" x .250"

See pages 100-111 for terminal block accessories

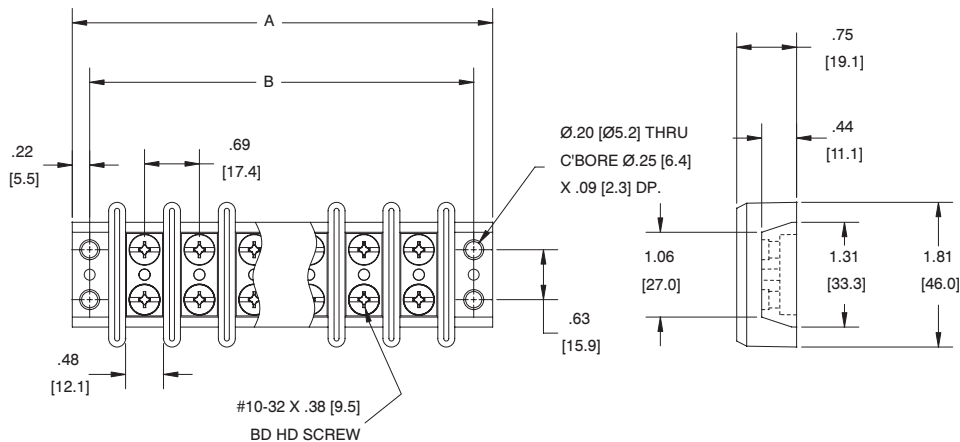

Double Row Terminal Blocks

Kulka® 604 GP Series

600 Volts AC/DC (Classes B/C)

Class D does not apply



604 GP 04

Specifications:

- Base, General Purpose Phenolic, 150°C
- Open Back Design (Insulator Strip required for Voltage Rating - see page 108)
- JJ (GDI-30F) Material Available
- Screws, #12-32 Binder Head, Phil-Slot, Brass
- Terminals, Plated Brass
- 1-8 Poles
- 7/8" Centers
- Wire Range With Wire Binding Screw #10 - #12 AWG – 30 Amps
- 70 Amps with Listed Wire Lugs
- UL Recognized File No. XCFR2.E47811
- CSA Certified File No. LR19766
- **CE**
- RoHS Compliant

Double Row Terminal Blocks

Kulka® Catalog #	# of poles	Dimensions	
		A	B
604 GP 01 PSB	1	2.28	1.75
604 GP 02 PSB	2	3.16	2.63
604 GP 03 PSB	3	4.03	3.50
604 GP 04 PSB	4	4.91	4.38
604 GP 05 PSB	5	5.78	5.25
604 GP 06 PSB	6	6.66	6.13
604 GP 07 PSB	7	7.53	7.00
604 GP 08 PSB	8	8.41	7.88

mm=dim X 25.4

For electronic drawings or 2D/3D CAD data,
send request to drawings@marathonsp.com

Hardware Options:

(Hardware options may affect ratings - consult Customer Service)

CATALOG # MSP	KULKA	PRODUCT DESCRIPTION	PAGE REFERENCE
	J 604	Line to Line Jumper	See Page 102
	2402	Stud 10-32 Brass (.43 H) Nuts included	See Page 105

See pages 100-111 for terminal block accessories

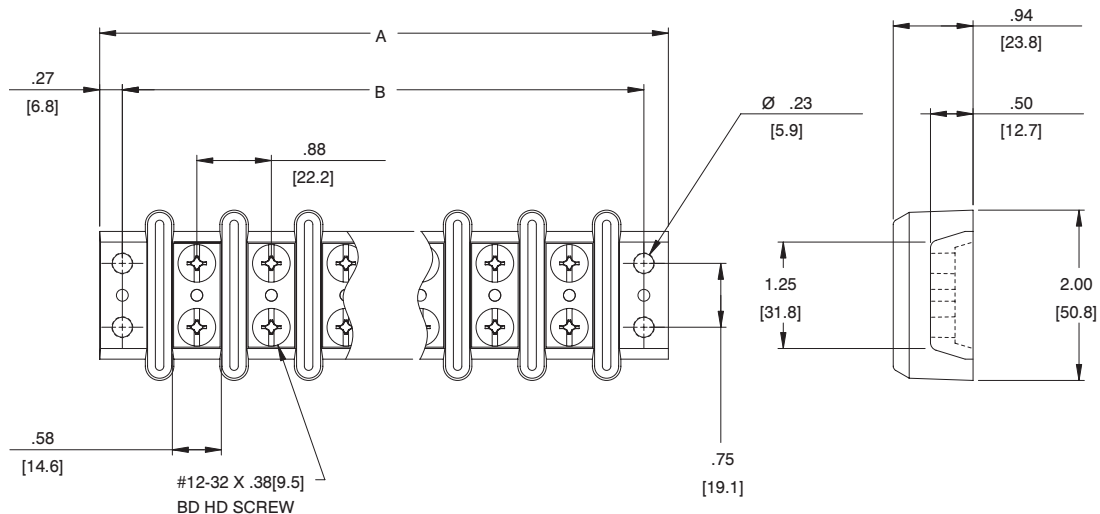

Double Row Terminal Blocks

Kulka® 605 GP Series

600 Volts AC/DC (Classes B/C)

Class D does not apply



605 GP 03

Specifications:

- Base, General Purpose Phenolic, 150°C
- Open Back Design (Insulator Strip required for Voltage Rating - see page 108)
- JJ (GDI-30F) Material Available
- Screws, #1/4-28 Binder Head, Slotted, Brass
- Terminals, Plated Brass
- 1-6 Poles
- 1 1/8" Centers
- Wire Range With Wire Binding Screw #10 - #12 AWG – 30 Amps
- 90 Amps with Listed Wire Lugs
- UL Recognized File No. XCFR2.E47811
- CSA Certified File No. LR19766
- **CE**
- RoHS Compliant

Kulka® Catalog #	# of poles	Dimensions	
		A	B
605 GP 01 SLB	1	2.88	2.25
605 GP 02 SLB	2	4.00	3.38
605 GP 03 SLB	3	5.13	4.50
605 GP 04 SLB	4	6.25	5.63
605 GP 05 SLB	5	7.38	6.75
605 GP 06 SLB	6	8.50	7.88

mm=dim X 25.4

For electronic drawings or 2D/3D CAD data,
send request to drawings@marathonsp.com

Hardware Options:

(Hardware options may affect ratings - consult Customer Service)

CATALOG #	PRODUCT DESCRIPTION	PAGE REFERENCE
MSP		
KULKA		
J 605	Line to Line Jumper	See Page 103
2502	Stud 1/4-28 Brass (.750 H) Nuts included	See Page 105
PSB	Phil-Slot Brass Screw	Consult C/S

See pages 100-111 for terminal block accessories

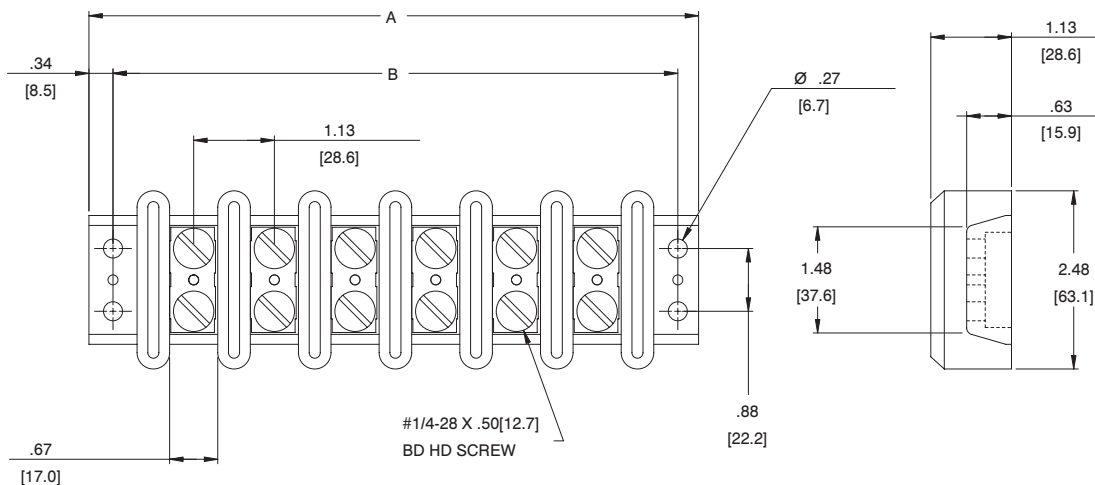

Double Row Terminal Blocks

621 RZ Series

600 Volts AC/DC (Class C)



621 RZ 06

Specifications:

- Base, Thermoplastic, 125°C (U.L. RTI)
- Closed Back Design
- Screws, #6-32 Binder Head, Phil-Slot, Steel
- Terminals, Plated Brass
- 1-30 Poles
- 7/16" Centers
- Wire Range With Wire Binding Screw #12 - #22 AWG – 20 Amps
- Wire Range With Sems Pressure Screw #12 - #22 AWG Stranded Copper Wire Only, 20 Amps
- UL Recognized File No. XCFR2.E62806
- CSA Certified File No. LR19766
- **CE**
- RoHS Compliant

MSP		Dimensions	
Catalog #	# of poles	A	B
621 RZ 01	1	1.19	0.88
621 RZ 02	2	1.62	1.31
621 RZ 03	3	2.06	1.75
621 RZ 04	4	2.50	2.19
621 RZ 05	5	2.94	2.63
621 RZ 06	6	3.37	3.06
621 RZ 07	7	3.81	3.50
621 RZ 08	8	4.25	3.94
621 RZ 09	9	4.69	4.38
621 RZ 10	10	5.12	4.81
621 RZ 11	11	5.56	5.25
621 RZ 12	12	6.00	5.69
621 RZ 13	13	6.44	6.13
621 RZ 14	14	6.87	6.56
621 RZ 15	15	7.31	7.00
621 RZ 16	16	7.75	7.44
621 RZ 17	17	8.19	7.88
621 RZ 18	18	8.62	8.31
621 RZ 19	19	9.06	8.75
621 RZ 20	20	9.50	9.19
621 RZ 21	21	9.94	9.63
621 RZ 22	22	10.37	10.06
621 RZ 23	23	10.81	10.50
621 RZ 24	24	11.25	10.94
621 RZ 25	25	11.69	11.38
621 RZ 26	26	12.12	11.81
621 RZ 27	27	12.56	12.25
621 RZ 28	28	13.00	12.69
621 RZ 29	29	13.44	13.13
621 RZ 30	30	13.87	13.56

mm=dim X 25.4

For electronic drawings or 2D/3D CAD data, send request to drawings@marathonsp.com

Hardware Options:

(Hardware options may affect ratings - consult Customer Service)

CATALOG #	PRODUCT DESCRIPTION	PAGE REFERENCE
MSP	KULKA	
KT37	Full Quick Connect (0° Flat)	See page 101
KT38	Full Quick Connect (45° Bend)	See page 101
KT39	Full Quick Connect (90° Bend)	See page 101
KT43	Half Quick Connect (0° Flat)	See page 101
KT44	Half Quick Connect (45° Bend)	See page 101
KT45	Half Quick Connect (90° Bend)	See page 101
ST	Full Solder	See page 102
3/4 ST	Half Solder	See page 102
LL 200HB	Line to Line Jumper	See page 103
601RJ(S)	Multiple Position Jumper	See page 103
3765	SEMS Pressure Saddle Screw	See page 103
3767	SEMS Pressure Saddle Screw with External Tooth Lock Washer	Consult C/S
PSB	Phil-Slot Brass Screw	Consult C/S

Quick Connects: .032" x .250"

See pages 100-111 for terminal block accessories

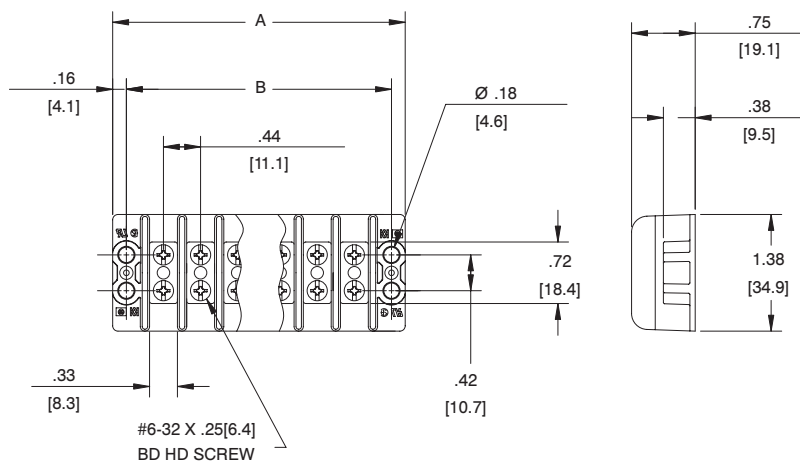

Double Row Terminal Blocks

670A RZ Series

300 Volts AC/DC (Class B)

150 Volts AC/DC (Class C)

Class D does not apply

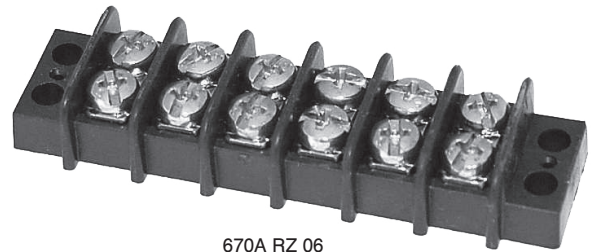

670A RZ 06

Specifications:

- Base, Thermoplastic, 130°C (U.L. RTI)
- Closed Back Design
- Screws, #6-32 Binder Head, Phil-Slot, Steel
- Terminals, Plated Brass
- 1-30 Poles
- 3/8" Centers
- Wire Range With Wire Binding Screw
#12 - #22 AWG – 20 Amps
- Wire Range With Sems Pressure Screw #14 - #22 AWG
Stranded or Solid Wire - 15 Amps
- UL Recognized File No. XCFR2.E47811
- CSA Certified File No. LR19766
- **CE**
- RoHS Compliant

MSP Catalog #	# of poles	Dimensions	
		A	B
670A RZ 01	1	1.03	0.75
670A RZ 02	2	1.41	1.13
670A RZ 03	3	1.78	1.50
670A RZ 04	4	2.16	1.88
670A RZ 05	5	2.53	2.25
670A RZ 06	6	2.91	2.63
670A RZ 07	7	3.28	3.00
670A RZ 08	8	3.66	3.38
670A RZ 09	9	4.03	3.75
670A RZ 10	10	4.41	4.13
670A RZ 11	11	4.78	4.50
670A RZ 12	12	5.16	4.88
670A RZ 13	13	5.53	5.25
670A RZ 14	14	5.91	5.63
670A RZ 15	15	6.28	6.00
670A RZ 16	16	6.66	6.38
670A RZ 17	17	7.03	6.75
670A RZ 18	18	7.41	7.13
670A RZ 19	19	7.78	7.50
670A RZ 20	20	8.16	7.88
670A RZ 21	21	8.53	8.25
670A RZ 22	22	8.91	8.63
670A RZ 23	23	9.28	9.00
670A RZ 24	24	9.66	9.38
670A RZ 25	25	10.03	9.75
670A RZ 26	26	10.41	10.13
670A RZ 27	27	10.78	10.50
670A RZ 28	28	11.16	10.88
670A RZ 29	29	11.53	11.25
670A RZ 30	30	11.91	11.63

mm=dim X 25.4

For electronic drawings or 2D/3D CAD data,
send request to drawings@marathonsp.com

Hardware Options:

(Hardware options may affect ratings - consult Customer Service)

CATALOG # MSP	KULKA PRODUCT DESCRIPTION	PAGE REFERENCE
	KT19 Full Quick Connect (0° Flat)	See page 101
	KT20 Full Quick Connect (45° Bend)	See page 101
	KT21 Full Quick Connect (90° Bend)	See page 101
	KT25 Half Quick Connect (0° Flat)	See page 101
	KT26 Half Quick Connect (45° Bend)	See page 101
	KT27 Half Quick Connect (90° Bend)	See page 101
	ST Full Solder	See page 102
	3/4 ST Half Solder	See page 102
L	Y Feed Thru Solder (.312)	See page 102
	J 600 Line to Line Jumper	See page 103
	600RJ(S) Multiple Position Jumper	See page 103
	3865 Sems Pressure Saddle Screw	See page 103
PSB	Phil-Slot Brass Screw	Consult C/S

Quick Connects: .020" x .187"

See pages 100-111 for terminal block accessories

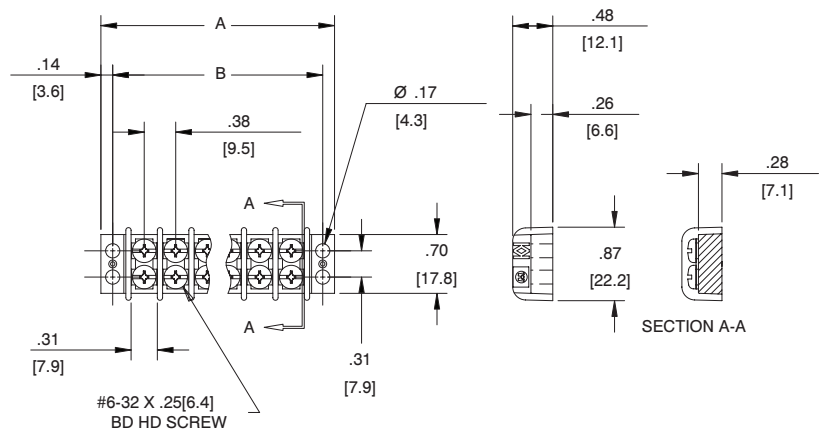

Double Row Terminal Blocks

671 RZ Series

300 Volts AC/DC (Class B)



671 RZ 06

Specifications:

- Base, Thermoplastic, 125°C (U.L. RTI)
- Closed Back Design
- Screws, #6-32 Binder Head, Phil-Slot, Steel
- Terminals, Plated Brass
- 1-30 Poles
- 7/16" Centers
- Wire Range With Wire Binding Screw
#12 - #22 AWG – 20 Amps
- Wire Range With Sems Pressure Screw #12 - #22 AWG
Stranded Copper Wire Only, 20 Amps
- UL Recognized File No. XCFR2.E62806
- CSA Certified File No. LR19766
- **CE**
- RoHS Compliant

MSP Catalog #	# of poles	Dimensions	
		A	B
671 RZ 01	1	1.19	0.88
671 RZ 02	2	1.62	1.31
671 RZ 03	3	2.06	1.75
671 RZ 04	4	2.50	2.19
671 RZ 05	5	2.94	2.63
671 RZ 06	6	3.37	3.06
671 RZ 07	7	3.81	3.50
671 RZ 08	8	4.25	3.94
671 RZ 09	9	4.69	4.38
671 RZ 10	10	5.12	4.81
671 RZ 11	11	5.56	5.25
671 RZ 12	12	6.00	5.69
671 RZ 13	13	6.44	6.13
671 RZ 14	14	6.87	6.56
671 RZ 15	15	7.31	7.00
671 RZ 16	16	7.75	7.44
671 RZ 17	17	8.19	7.88
671 RZ 18	18	8.62	8.31
671 RZ 19	19	9.06	8.75
671 RZ 20	20	9.50	9.19
671 RZ 21	21	9.94	9.63
671 RZ 22	22	10.37	10.06
671 RZ 23	23	10.81	10.50
671 RZ 24	24	11.25	10.94
671 RZ 25	25	11.69	11.38
671 RZ 26	26	12.12	11.81
671 RZ 27	27	12.56	12.25
671 RZ 28	28	13.00	12.69
671 RZ 29	29	13.44	13.13
671 RZ 30	30	13.87	13.56

mm=dim X 25.4

For electronic drawings or 2D/3D CAD data,
send request to drawings@marathonsp.com

Hardware Options:

(Hardware options may affect ratings - consult Customer Service)

CATALOG # MSP	PRODUCT KULKA DESCRIPTION	PAGE REFERENCE
KT37	Full Quick Connect (0° Flat)	See page 101
KT38	Full Quick Connect (45° Bend)	See page 101
KT39	Full Quick Connect (90° Bend)	See page 101
KT43	Half Quick Connect (0° Flat)	See page 101
KT44	Half Quick Connect (45° Bend)	See page 101
KT45	Half Quick Connect (90° Bend)	See page 101
ST	Full Solder	See page 102
3/4 ST	Half Solder	See page 102
J 601	Line to Line Jumper	See page 103
601RJ(S)	Multiple Position Jumper	See page 103
3765	SEMS Pressure Saddle Screw	See page 103
3767	SEMS Pressure Saddle Screw with External Tooth Lock Washer	Consult C/S
PSB	Phil-Slot Brass Screw	Consult C/S

Quick Connects: .032" x .250"

See pages 100-111 for terminal block accessories

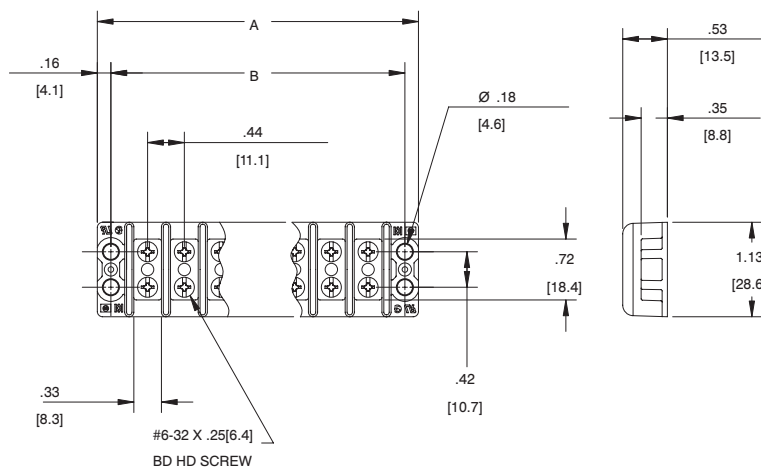

Double Row Terminal Blocks

672 RZ Series

600 Volts AC/DC (Class C)



672 RZ 06

Specifications:

- Base, Thermoplastic, 125°C (U.L. RTI)
- Closed Back Design
- Screws, #8-32 Binder Head, Phil-Slot, Steel
- Terminals, Plated Brass
- 1-24 Poles
- 9/16" Centers
- Wire Range With Wire Binding Screw
#10 - #14 AWG – 30 Amps
- Wire Range With Sems Pressure Screw #10 - #22 AWG
Stranded Copper Wire Only, 30 Amps
- UL Recognized File No. XCFR2.E47811
- CSA Certified File No. LR19766
- **CE**
- RoHS Compliant

MSP Catalog #	# of poles	Dimensions	
		A	B
672 RZ 01	1	1.54	1.13
672 RZ 02	2	2.10	1.69
672 RZ 03	3	2.66	2.25
672 RZ 04	4	3.22	2.81
672 RZ 05	5	3.79	3.38
672 RZ 06	6	4.35	3.94
672 RZ 07	7	4.91	4.50
672 RZ 08	8	5.47	5.06
672 RZ 09	9	6.04	5.63
672 RZ 10	10	6.60	6.19
672 RZ 11	11	7.16	6.75
672 RZ 12	12	7.72	7.31
672 RZ 13	13	8.29	7.88
672 RZ 14	14	8.85	8.44
672 RZ 15	15	9.41	9.00
672 RZ 16	16	9.97	9.56
672 RZ 17	17	10.54	10.13
672 RZ 18	18	11.10	10.69
672 RZ 19	19	11.66	11.25
672 RZ 20	20	12.22	11.81
672 RZ 21	21	12.79	12.38
672 RZ 22	22	13.35	12.94
672 RZ 23	23	13.91	13.50
672 RZ 24	24	14.47	14.06

mm=dim X 25.4

For electronic drawings or 2D/3D CAD data,
send request to drawings@marathonsp.com

Hardware Options:

(Hardware options may affect ratings - consult Customer Service)

CATALOG # MSP	KULKA	PRODUCT DESCRIPTION	PAGE REFERENCE
	KT55	Full Quick Connect (0° Flat)	See page 101
	KT56	Full Quick Connect (45° Bend)	See page 101
	KT57	Full Quick Connect (90° Bend)	See page 101
	KT61	Half Quick Connect (0° Flat)	See page 101
	KT62	Half Quick Connect (45° Bend)	See page 101
	KT63	Half Quick Connect (90° Bend)	See page 101
	ST	Full Solder	See page 102
	3/4 ST	Half Solder	See page 102
	J 602	Line to Line Jumper	See page 103
	3786	SEMS Pressure Saddle Screw	See page 103
	3787	Sems Pressure Saddle Screw with External Tooth Lock Washer	Consult C/S
PSB		Phil-Slot Brass Screw	Consult C/S

Quick Connects: .032" x .250"

See pages 100-111 for terminal block accessories

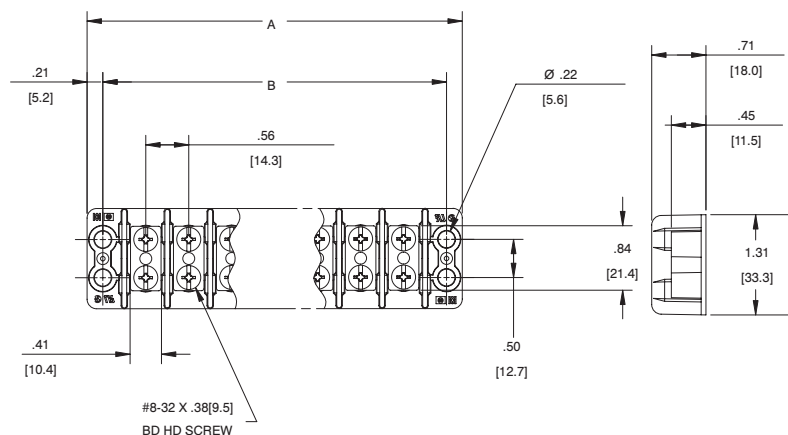

Single Row Terminal Blocks

General Information:

Single Row Terminal Blocks are available in four basic line to line molding sizes. Some are available in either open or feed thru/printed circuit designs. The basic material is phenolic. Modifications are also provided on most terminal blocks, including marking strips.

Ratings and Standards:

The voltage ratings of terminal blocks are based upon the minimum spacing between electrically conductive parts line to line through air and over surface and line to ground through air and over surface.

Class A

Service equipment including deadfront switchboards, panel boards, service entrance devices.

Class B

Commercial appliances including business equipment, electronic data processing equipment and the like.

Class C

General industrial and machine tool controls which can be further defined as equipment falling under UL 1059.

Ratings based on UL 1059 may be higher in some cases depending on application.

Spacing Requirements*:

	Voltage	Thru Air	Over Surface
Class A	51-150	.500	.750
	151-300	.750	1.250
	301-600	1.000	2.000
Class B	51-150	.063	.063
	151-300	.094	.094
	301-600	.375	.500
Class C	51-150	.125	.250
	151-300	.250	.375
	301-600	.375	.500

*In Inches

Reference Chart:

Series	Catalog Page	Amps	Volts	Base Material	Max Wire Size	Screw Size	Inches L to L	# of Lines	Features
411	91	5	300*	Phenolic	#18	2-56	.250	1-23	Open Back
599/799	92	15	150	Phenolic	#16	5-40	.375	1-30	Open Back
699/899	93	20	150	Phenolic	#14	6-32	.437	1-23	Open Back
812/912	94	30	600	Phenolic	#12	8-32	.562	1-18	Open Back
1690	95-96	20	300	Phenolic	#14	6-32	.437	1-25	Feed Thru
2590	97	15	150	Phenolic	#16	6-32	.375	1-25	Printed Circuit
2690	98-99	20	300	Phenolic	#14	6-32/8-32	.437	1-25	Printed Circuit

All voltage ratings based on Class C requirements unless noted.

Open back terminal blocks require an insulator strip to achieve voltage rating.

*Based on Class B requirements.

Single Row Terminal Blocks

Kulka® 411 GP Series

300 Volts AC/DC*

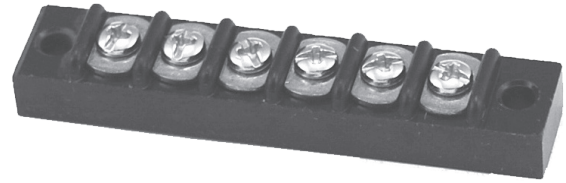

411 GP 06 PSB

Specifications:

- Base, Phenolic, 150°C
- Open Back Design (Insulator Strip Required for Voltage Rating - see page 108)
- JJ (GDI-30F) Material Available
- Screws, #2-56 Binder Head, Phil-Slot, Brass
- Terminals, Plated Brass
- 1-23 Poles
- 1/4" Centers
- Wire Range With Wire Binding Screw
#18 - #20 AWG – 5 Amps
- UL Recognized File No. XCFR2.E47811
- CSA Certified File No. LR19766
- **CE**
- RoHS Compliant

Kulka® Catalog #	# of poles	Dimensions	
		A	B
411 GP 01 PSB	1	0.75	0.50
411 GP 02 PSB	2	1.00	0.75
411 GP 03 PSB	3	1.25	1.00
411 GP 04 PSB	4	1.50	1.25
411 GP 05 PSB	5	1.75	1.50
411 GP 06 PSB	6	2.00	1.75
411 GP 07 PSB	7	2.25	2.00
411 GP 08 PSB	8	2.50	2.25
411 GP 09 PSB	9	2.75	2.50
411 GP 10 PSB	10	3.00	2.75
411 GP 11 PSB	11	3.25	3.00
411 GP 12 PSB	12	3.50	3.25
411 GP 13 PSB	13	3.75	3.50
411 GP 14 PSB	14	4.00	3.75
411 GP 15 PSB	15	4.25	4.00
411 GP 16 PSB	16	4.50	4.25
411 GP 17 PSB	17	4.75	4.50
411 GP 18 PSB	18	5.00	4.75
411 GP 19 PSB	19	5.25	5.00
411 GP 20 PSB	20	5.50	5.25
411 GP 21 PSB	21	5.75	5.50
411 GP 22 PSB	22	6.00	5.75
411 GP 23 PSB	23	6.25	6.00

mm = dim X 25.4

*Based on Class B Requirements

For electronic drawings or 2D/3D CAD data,
send request to drawings@marathonsp.com

Hardware Options:

(Hardware options may affect ratings - consult Customer Service)

CATALOG #	PRODUCT DESCRIPTION	PAGE REFERENCE
MSP KT10	Full Quick Connect (0° Flat)	See page 100
MSP KT11	Full Quick Connect (45° Bend)	See page 100
MSP KT12	Full Quick Connect (90° Bend)	See page 100
MSP KT16	Half Quick Connect (0° Flat)	See page 100
MSP KT17	Half Quick Connect (45° Bend)	See page 100
MSP KT18	Half Quick Connect (90° Bend)	See page 100
MSP ST	Full Solder	See page 102
MSP 3/4 ST	Half Solder	See page 102
MSP Z	Lug over the Side (.312)	Consult C/S
MSP J 410	Line to Line Jumper	See page 103
MSP 1921	Printed Circuit Pin (.125) (Over the Side)	Consult C/S
MSP 1904	Feed Thru Solder	Consult C/S

Quick Connects: .020" x .110"

See pages 100-111 for terminal block accessories

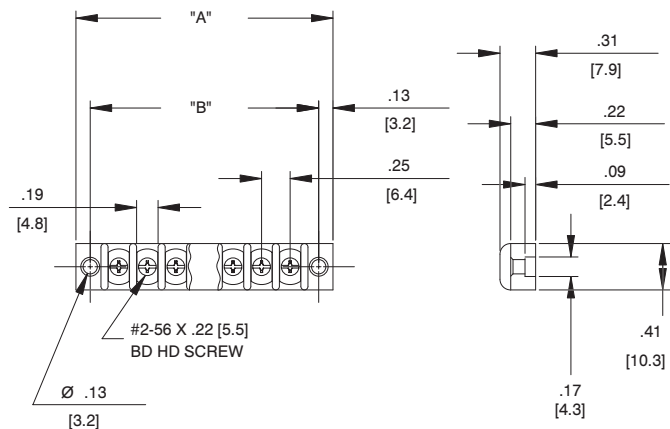

Single Row Terminal Blocks

Kulka® 599/799 GP Series

150 Volts AC/DC



599 GP 06 PSB

Specifications:

- Base, Phenolic, 150°C
- Open Back Design (Insulator Strip Required for Voltage Rating - see page 108)
- JJ (GDI-30F) Material Available
- Screws, #5-40 Binder Head, Phil-Slot, Brass
- Terminals, Plated Brass
- 1-30 Poles
- 3/8" Centers
- Wire Range With Wire Binding Screw #16 - #22 AWG – 15 Amps
- 799 Series (Riveted KT's) - shown at right, see page 100 for KT's
- UL Recognized File No. XCFR2.E47811
- CSA Certified File No. LR19766
- CE
- RoHS Compliant



799 Series

Hardware Options:

(Hardware options may affect ratings - consult Customer Service)

CATALOG #	PRODUCT DESCRIPTION	PAGE REFERENCE
KT28	Full Quick Connect (0° Flat)	See page 100
KT29	Full Quick Connect (45° Bend)	See page 100
KT30	Full Quick Connect (90° Bend)	See page 100
KT34	Half Quick Connect (0° Flat)	See page 100
KT35	Half Quick Connect (45° Bend)	See page 100
KT36	Half Quick Connect (90° Bend)	See page 100
3/4 ST	Half Solder	See page 102
Z	Lug over the Side (.312)	Consult C/S
J 600	Line to Line Jumper	See page 103
600 RJ(S)	Multiple Position Jumper	See page 103
2002	Stud	See page 105
2004	Feed Thru Solder	See page 105
2020	Solder Pin	See page 105
2021	Solder Pin (Slotted Screw)	See page 105

Quick Connects: .020" x .187"

See pages 100-111 for terminal block accessories

Kulka® Catalog #	# of poles	Dimensions	
		A	B
599 GP 01 PSB	1	1.03	0.75
599 GP 02 PSB	2	1.41	1.12
599 GP 03 PSB	3	1.78	1.50
599 GP 04 PSB	4	2.16	1.88
599 GP 05 PSB	5	2.53	2.25
599 GP 06 PSB	6	2.91	2.63
599 GP 07 PSB	7	3.28	3.00
599 GP 08 PSB	8	3.66	3.38
599 GP 09 PSB	9	4.03	3.75
599 GP 10 PSB	10	4.41	4.13
599 GP 11 PSB	11	4.78	4.50
599 GP 12 PSB	12	5.16	4.88
599 GP 13 PSB	13	5.53	5.25
599 GP 14 PSB	14	5.91	5.63
599 GP 15 PSB	15	6.28	6.00
599 GP 16 PSB	16	6.66	6.38
599 GP 17 PSB	17	7.03	6.75
599 GP 18 PSB	18	7.41	7.13
599 GP 19 PSB	19	7.78	7.50
599 GP 20 PSB	20	8.16	7.88
599 GP 21 PSB	21	8.53	8.25
599 GP 22 PSB	22	8.91	8.63
599 GP 23 PSB	23	9.28	9.00
599 GP 24 PSB	24	9.66	9.38
599 GP 25 PSB	25	10.03	9.75
599 GP 26 PSB	26	10.41	10.13
599 GP 27 PSB	27	10.78	10.50
599 GP 28 PSB	28	11.16	10.88
599 GP 29 PSB	29	11.53	11.25
599 GP 30 PSB	30	11.91	11.63

mm = dim X 25.4

For electronic drawings or 2D/3D CAD data, send request to drawings@marathonsp.com

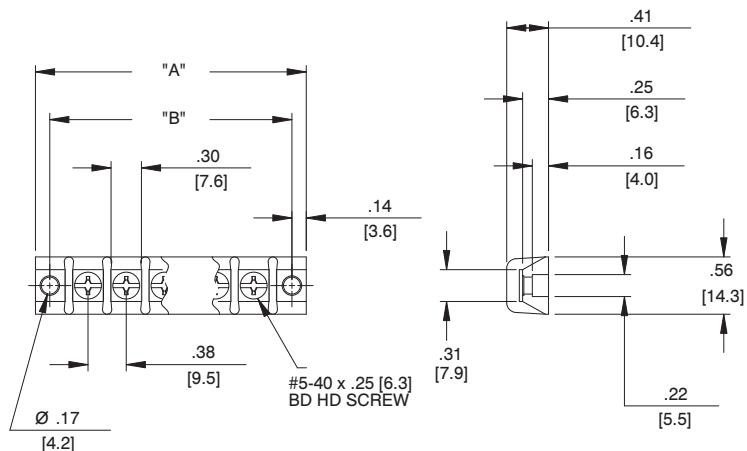

Single Row Terminal Blocks

Kulka® 699/899 GP Series

150 Volts AC/DC



699 GP 06 PSB

Specifications:

- Base, Phenolic, 150°C
- Open Back Design (Insulator Strip Required for Voltage Rating - see page 108)
- JJ (GDI-30F) Material Available
- Screws, #6-32 Binder Head, Phil-Slot, Steel
- Terminals, Plated Brass
- 1-23 Poles
- 7/16" Centers

- Wire Range With Wire Binding Screw #14 - #16 AWG – 20 Amps
- 899 Series (Riveted KT's) - shown at right, see page 100 for KT's
- UL Recognized File No. XCFR2.E47811
- CSA Certified File No. LR19766
- **CE**
- RoHS Compliant

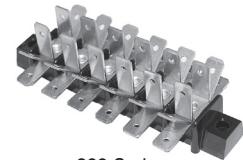

899 Series

Kulka® Catalog #	# of poles	Dimensions	
		A	B
699 GP 01	1	1.19	0.88
699 GP 02	2	1.63	1.31
699 GP 03	3	2.06	1.75
699 GP 04	4	2.50	2.19
699 GP 05	5	2.94	2.63
699 GP 06	6	3.38	3.06
699 GP 07	7	3.81	3.50
699 GP 08	8	4.25	3.94
699 GP 09	9	4.69	4.38
699 GP 10	10	5.12	4.81
699 GP 11	11	5.56	5.25
699 GP 12	12	6.00	5.69
699 GP 13	13	6.44	6.13
699 GP 14	14	6.87	6.56
699 GP 15	15	7.31	7.00
699 GP 16	16	7.75	7.44
699 GP 17	17	8.19	7.88
699 GP 18	18	8.62	8.31
699 GP 19	19	9.06	8.75
699 GP 20	20	9.50	9.19
699 GP 21	21	9.94	9.63
699 GP 22	22	10.37	10.06
699 GP 23	23	10.81	10.50

mm = dim X 25.4

For electronic drawings or 2D/3D CAD data, send request to drawings@marathonsp.com

Hardware Options:

(Hardware options may affect ratings - consult Customer Service)

CATALOG #	PRODUCT DESCRIPTION	PAGE REFERENCE
MSP KT46	Full Quick Connect (0° Flat)	See page 100
MSP KT47	Full Quick Connect (45° Bend)	See page 100
MSP KT48	Full Quick Connect (90° Bend)	See page 100
MSP KT52	Half Quick Connect (0° Flat)	See page 100
MSP KT53	Half Quick Connect (45° Bend)	See page 100
MSP KT54	Half Quick Connect (90° Bend)	See page 100
MSP 3/4 ST	Half Solder	See page 102
MSP Z	Lug over the Side (.437)	Consult C/S
MSP J 601	Line to Line Jumper	See page 103
MSP 601 RJ(S)	Multiple Position Jumper	See page 103
MSP 2102	Stud	See page 105
MSP 2104	Feed Thru Solder	See page 105
MSP 2120	Solder Pin	See page 105
MSP 2121	Solder Pin	See page 105
PSB	Phil-Slot Brass Screw	Consult C/S

Quick Connects: .032" x .250"

See pages 100-111 for terminal block accessories

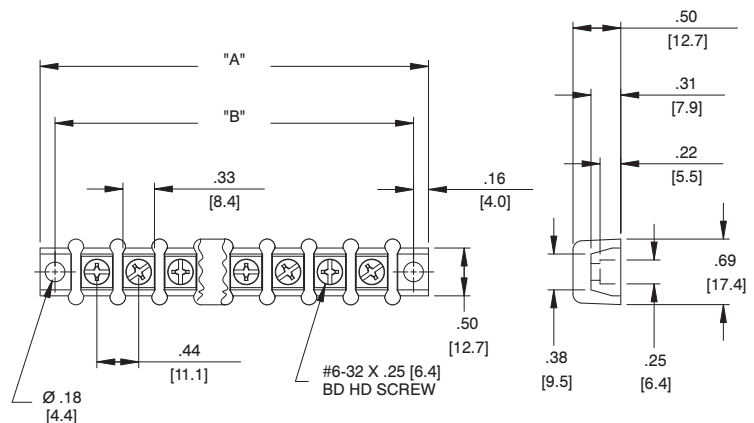

Single Row Terminal Blocks

Kulka® 812/912 GP Series

600 Volts AC/DC



812 GP 06 PSB

Specifications:

- Base, Phenolic, 150°C
- Open Back Design (Insulator Strip Required for Voltage Rating - see page 108)
- JJ (GDI-30F) Material Available
- Screws, #8-32 Binder Head, Phil-Slot, Steel
- Terminals, Plated Brass
- 1-18 Poles
- 9/16" Centers
- Wire Range With Wire Binding Screw
#12 - #14 AWG – 30 Amps
- 912 Series (Riveted KT's) - shown at right, see page 100 for KT's
- UL Recognized File No. XCFR2.E47811
- CSA Certified File No. LR19766
- **CE**
- RoHS Compliant

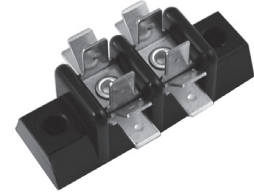

912 Series

Kulka® Catalog #	# of poles	Dimensions	
		A	B
812 GP 01	1	1.53	1.13
812 GP 02	2	2.09	1.69
812 GP 03	3	2.66	2.25
812 GP 04	4	3.22	2.81
812 GP 05	5	3.78	3.38
812 GP 06	6	4.34	3.94
812 GP 07	7	4.91	4.50
812 GP 08	8	5.47	5.06
812 GP 09	9	6.03	5.63
812 GP 10	10	6.59	6.19
812 GP 11	11	7.16	6.75
812 GP 12	12	7.72	7.31
812 GP 13	13	8.28	7.88
812 GP 14	14	8.84	8.44
812 GP 15	15	9.41	9.00
812 GP 16	16	9.97	9.56
812 GP 17	17	10.53	10.13
812 GP 18	18	11.09	10.69

mm = dim X 25.4

For electronic drawings or 2D/3D CAD data,
send request to drawings@marathonsp.com

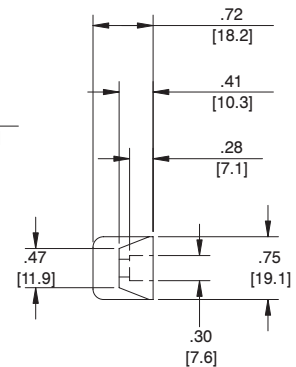
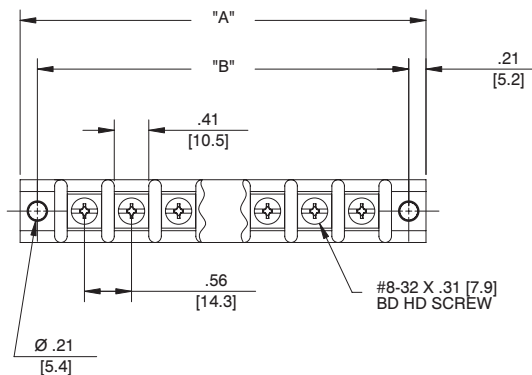

Hardware Options:

(Hardware options may affect ratings - consult Customer Service)

CATALOG #	PRODUCT DESCRIPTION	PAGE REFERENCE
MSP		
KULKA		
KT73	Full Quick Connect (0° Flat)	See page 100
KT74	Full Quick Connect (45° Bend)	See page 100
KT75	Full Quick Connect (90° Bend)	See page 100
KT79	Half Quick Connect (0° Flat)	See page 100
KT80	Half Quick Connect (45° Bend)	See page 100
KT81	Half Quick Connect (90° Bend)	See page 100
3/4 ST	Half Solder	See page 102
Z	Lug over the Side (.641)	Consult C/S
J 602	Line to Line Jumper	See page 103
2202	Stud	See page 105
2204	Feed Thru Solder	See page 105
PSB	Phil-Slot Brass Screw	Consult C/S

Quick Connects: .032" x .250"

See pages 100-111 for terminal block accessories

Single Row Terminal Blocks

Kulka® 1690 GP Series

300 Volts AC/DC

Specifications:

- Base, Phenolic, 150°C
- Screws, #6-32 Binder Head, Phil-Slot, Brass
- Terminals, Plated Brass
- 7/16" Centers
- Wire Range #14 Max. - 20 Amps
- UL Recognized File No. XCFR2.E47811
- CSA Certified File No. LR19766
- **CE**
- RoHS Compliant



TERMINAL BLOCK SERIES

# of poles	1691 GP 1692 GP 1693 GP		1694 GP 1695 GP 1696 GP		1697 GP 1698 GP 1699 GP	
	A	B	A	B	A	B
1	0.34	--	1.22	0.88	0.53	--
2	0.78	0.44	1.66	1.31	0.97	0.44
3	1.22	0.88	2.09	1.75	1.41	0.88
4	1.66	1.31	2.53	2.19	1.84	1.31
5	2.09	1.75	2.97	2.63	2.28	1.75
6	2.53	2.19	3.41	3.06	2.72	2.19
7	2.97	2.63	3.84	3.50	3.16	2.63
8	3.41	3.06	4.28	3.94	3.59	3.06
9	3.84	3.50	4.72	4.38	4.03	3.50
10	4.28	3.94	5.16	4.81	4.47	3.94
11	4.72	4.38	5.59	5.25	4.91	4.38
12	5.16	4.81	6.03	5.69	5.34	4.81
13	5.59	5.25	6.47	6.13	5.78	5.25
14	6.03	5.69	6.91	6.56	6.22	5.69
15	6.47	6.13	7.34	7.00	6.66	6.13
16	6.91	6.56	7.78	7.44	7.09	6.56
17	7.34	7.00	8.22	7.88	7.53	7.00
18	7.78	7.44	8.66	8.31	7.97	7.44
19	8.22	7.88	9.09	8.75	8.41	7.88
20	8.66	8.31	9.53	9.19	8.84	8.31
21	9.09	8.75	9.97	9.63	9.28	8.75
22	9.53	9.19	10.41	10.06	9.72	9.19
23	9.97	9.63	10.84	10.50	10.16	9.63
24	10.41	10.06	--	--	--	--
25	10.84	10.50	--	--	--	--

mm = dim X 25.4

Include "PSB" after part # when ordering (169X GP XX PSB)

See page 96 for 1690 Series Terminal block dimensions.

Hardware Options:

(Hardware options may affect ratings - consult Customer Service)

CATALOG # MSP KULKA	PRODUCT DESCRIPTION	PAGE REFERENCE
KT46	Full Quick Connect (0° Flat)	See page 100
KT47	Full Quick Connect (45° Bend)	See page 100
KT48	Full Quick Connect (90° Bend)	See page 100
KT52	Half Quick Connect (0° Flat)	See page 100
KT53	Half Quick Connect (45° Bend)	See page 100
KT54	Half Quick Connect (90° Bend)	See page 100
3/4 ST	Half Solder	See page 102
J 601	Line to Line Jumper	See page 103
601 RJ(S)	Multiple Position Jumper	See page 103

Quick Connects: .032" x .250"

See pages 100-111 for terminal block accessories

Single Row Terminal Blocks

Kulka® 1690 GP Series (cont.)

TERMINAL BLOCK SERIES 1691 GP / 1692 GP / 1693 GP

- 1691 GP Series** Solder terminal
K = .52 [13.10]; W = .06 [1.59]
- 1692 GP Series** Kliptite terminal
- 1693 GP Series** Solder terminal
K = .58 [14.68]; W = .13 [3.18]

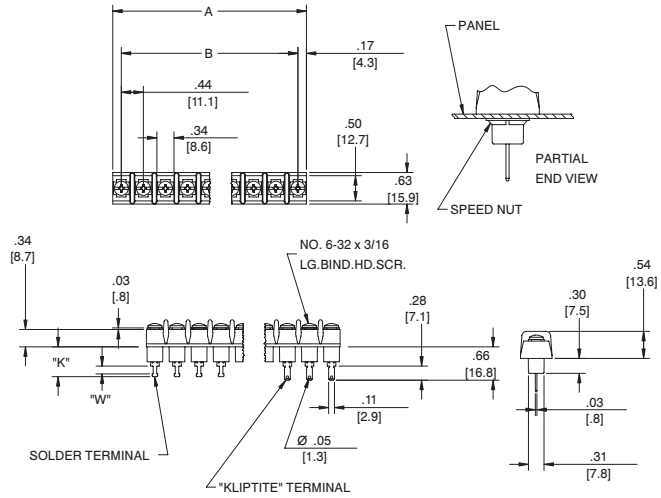

TERMINAL BLOCK SERIES 1694 GP / 1695 GP / 1696 GP

- 1694 GP Series** Solder terminal
K = .52 [13.10]; W = .06 [1.59]
- 1695 GP Series** Kliptite terminal
- 1696 GP Series** Solder terminal
K = .58 [14.68]; W = .13 [3.18]

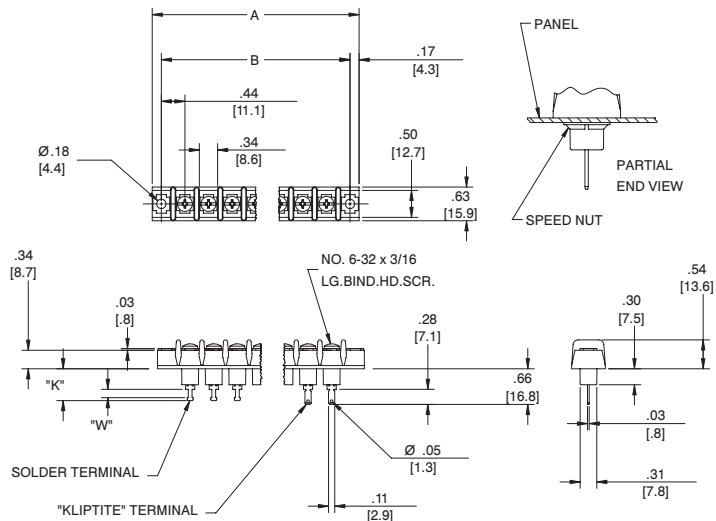

TERMINAL BLOCK SERIES 1697 GP / 1698 GP / 1699 GP

- 1697 GP Series** Solder terminal
K = .52 [13.10]; W = .06 [1.59]
- 1698 GP Series** Kliptite terminal
- 1699 GP Series** Solder terminal
K = .58 [14.68]; W = .13 [3.18]

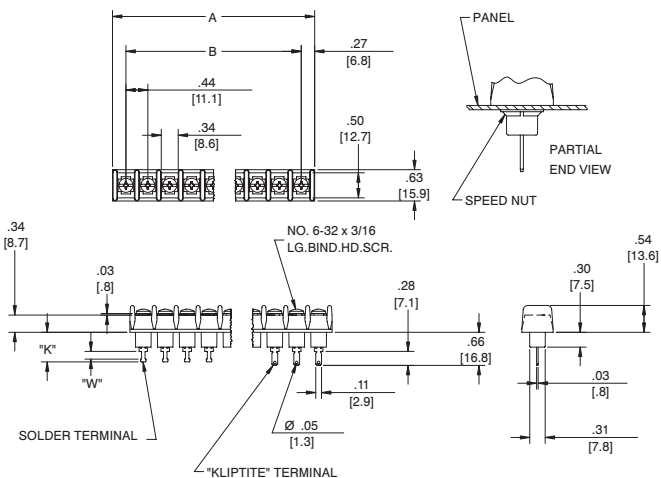

For electronic drawings or 2D/3D CAD data,
send request to drawings@marathonsp.com

Single Row Terminal Blocks

Kulka® 2590 GP Series

150 Volts AC/DC

Specifications:

- Base, Phenolic, 150°C
- Screws, #6-32 Binder Head, Slotted, Brass
- Terminals, Plated Brass
- 3/8" Centers
- Wire Range #16 Max. - 15 Amps
- The Suitability Of These Devices For Greater Currents Shall Be Determined In the End-Use Application
- UL Recognized File No. XCFR2.E47811
- CSA Certified File No. LR19766
- **CE**
- RoHS Compliant



2599A GP 04 PSB



2591A GP 04 PSB

Series 2591A GP / 2593A GP

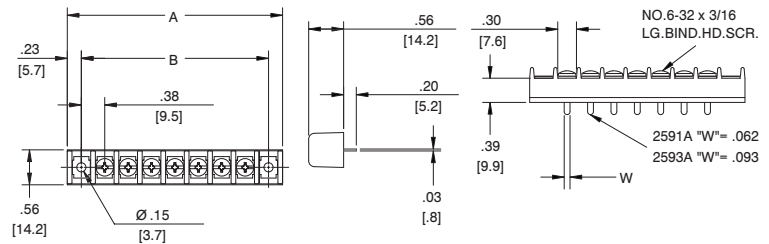

Series 2597A GP / 2599A GP

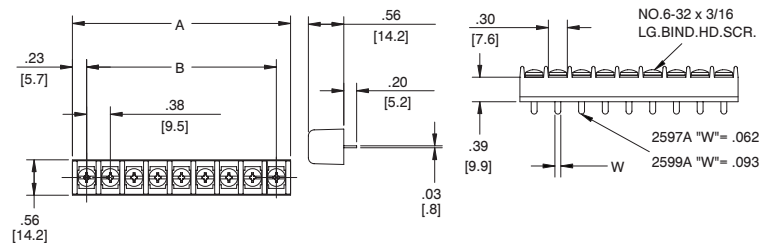

Hardware Options:

(Hardware options may affect ratings - consult Customer Service)

TERMINAL BLOCK SERIES				
# of poles	2591A GP 2593A GP		2597A GP 2599A GP	
	A	B	A	B
1	1.19	0.75	0.44	--
2	1.56	1.13	0.81	0.38
3	1.94	1.50	1.19	0.75
4	2.31	1.88	1.56	1.13
5	2.69	2.25	1.94	1.50
6	3.06	2.63	2.31	1.88
7	3.44	3.00	2.69	2.25
8	3.81	3.38	3.06	2.63
9	4.19	3.75	3.44	3.00
10	4.56	4.13	3.81	3.38
11	4.94	4.50	4.19	3.75
12	5.31	4.88	4.56	4.13
13	5.69	5.25	4.94	4.50
14	6.06	5.63	5.31	4.88
15	6.44	6.00	5.69	5.25
16	6.81	6.38	6.06	5.63
17	7.19	6.75	6.44	6.00
18	7.56	7.13	6.81	6.38
19	7.94	7.50	7.19	6.75
20	8.31	7.88	7.56	7.13
21	8.69	8.25	7.94	7.50
22	9.06	8.63	8.31	7.88
23	9.44	9.00	8.69	8.25
24	--	--	9.06	8.63
25	--	--	9.44	9.00

mm = dim X 25.4

Include "PSB" after part # when ordering
(259XA GP XX PSB)

For electronic drawings or 2D/3D CAD data,
send request to drawings@marathonsp.com

Datasheets available at marathonsp.com

CATALOG #	PRODUCT DESCRIPTION	PAGE REFERENCE
MSP	KULKA	
KT28	Full Quick Connect (0° Flat)	See page 100
KT29	Full Quick Connect (45° Bend)	See page 100
KT30	Full Quick Connect (90° Bend)	See page 100
KT34	Half Quick Connect (0° Flat)	See page 100
KT35	Half Quick Connect (45° Bend)	See page 100
KT36	Half Quick Connect (90° Bend)	See page 100
3/4 ST	Half Solder	See page 102
Y	Lug Over the Side (.359)	See page 102
Z	Lug Over the Side (.172)	See page 102
J 600	Line to Line Jumper	See page 103
600 RJ(S)	Multiple Position Jumper	See page 103
3000	Wire Wrap Lug (.641)	Consult C/S
2591A PC	Printed Circuit (.20 x .062)	Consult C/S
2593A PC	Printed Circuit (.20 x .093)	Consult C/S
2597A PC	Printed Circuit (.20 x .062)	Consult C/S
2599A PC	Printed Circuit (.20 x .093)	Consult C/S

Quick Connects: .032" x .250"

See pages 100-111 for terminal block accessories

Single Row Terminal Blocks

Kulka® 2690 GP Series

300 Volts AC/DC

Specifications:

- Base, Phenolic, 150°C
- Screws, #6-32 Binder Head, Slotted or #8-32 Binder Head, Slotted, Brass
- Terminals, Plated Brass
- 7/16" Centers
- Wire Range #14-16 AWG - 20 Amps
- UL Recognized File No. XCFR2.E47811
- CSA Certified File No. LR19766
- CE
- RoHS Compliant

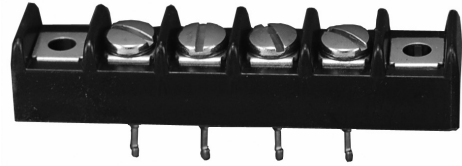

TERMINAL BLOCK SERIES

# of poles	2694 GP / 2694A GP 2695 GP / 2695A GP 2696 GP / 2696A GP		2697 GP / 2697A GP 2698 GP / 2698A GP 2699 GP / 2699A GP	
	Dimensions		Dimensions	
	A	B	A	B
1	1.41	0.88	0.53	--
2	1.84	1.31	0.97	0.44
3	2.28	1.75	1.41	0.88
4	2.72	2.19	1.84	1.31
5	3.16	2.63	2.28	1.75
6	3.59	3.06	2.72	2.19
7	4.03	3.50	3.16	2.63
8	4.47	3.94	3.59	3.06
9	4.91	4.38	4.03	3.50
10	5.34	4.81	4.47	3.94
11	5.78	5.25	4.91	4.38
12	6.22	5.69	5.34	4.81
13	6.66	6.13	5.78	5.25
14	7.09	6.56	6.22	5.69
15	7.53	7.00	6.66	6.13
16	7.97	7.44	7.09	6.56
17	8.41	7.88	7.53	7.00
18	8.84	8.31	7.97	7.44
19	9.28	8.75	8.41	7.88
20	9.72	9.19	8.84	8.31
21	10.16	9.63	9.28	8.75
22	10.59	10.06	9.72	9.19
23	11.03	10.50	10.16	9.63
24			10.59	10.06
25			11.03	10.50

mm = dim X 25.4

Include "PSB" after part # when ordering
(269XX GP XX PSB)

See page 99 for 1690 Series Terminal block dimensions.

Hardware Options:

(Hardware options may affect ratings - consult Customer Service)

CATALOG #	PRODUCT DESCRIPTION	PAGE REFERENCE
MSP	KULKA	
KT28	Full Quick Connect (0° Flat)	See page 100
KT29	Full Quick Connect (45° Bend)	See page 100
KT30	Full Quick Connect (90° Bend)	See page 100
KT34	Half Quick Connect (0° Flat)	See page 100
KT35	Half Quick Connect (45° Bend)	See page 100
KT36	Half Quick Connect (90° Bend)	See page 100
KT46	Full Quick Connect (0° Flat)	See page 100
KT47	Full Quick Connect (45° Bend)	See page 100
KT48	Full Quick Connect (90° Bend)	See page 100
KT52	Half Quick Connect (0° Flat)	See page 100
KT53	Half Quick Connect (45° Bend)	See page 100
KT54	Half Quick Connect (90° Bend)	See page 100
3/4 ST	Half Solder	See page 102
Y	Lug Over the Side (.609)	See page 102
Z	Lug Over the Side (.344)	See page 102
J 601	Line to Line Jumper	See page 103
601 RJ(S)	Multiple Position Jumper	See page 103

Quick Connects (KT28-36): .020" x .187" - Quick Connects (KT46-54): .032" x .250"

See pages 100-111 for terminal block accessories

Single Row Terminal Blocks

Kulka® 2690 GP Series (cont.)

TERMINAL BLOCK SERIES: 2694 GP / 2694A GP / 2695 GP 2695A GP / 2696 GP / 2696A GP

DEFINITION BARRIER ENDS:

2694 GP	#6-32 Brass Screw, Printed Circuit Width = .062	2694A GP	#8-32 Brass Screw, Printed Circuit Width = .062
2695 GP	#6-32 Brass Screw, Solder Turret (not shown)	2695A GP	#8-32 Brass Screw, Solder Turret (not shown)
2696 GP	#6-32 Brass Screw, Printed Circuit Width = .093	2696A GP	#8-32 Brass Screw, Printed Circuit Width = .093

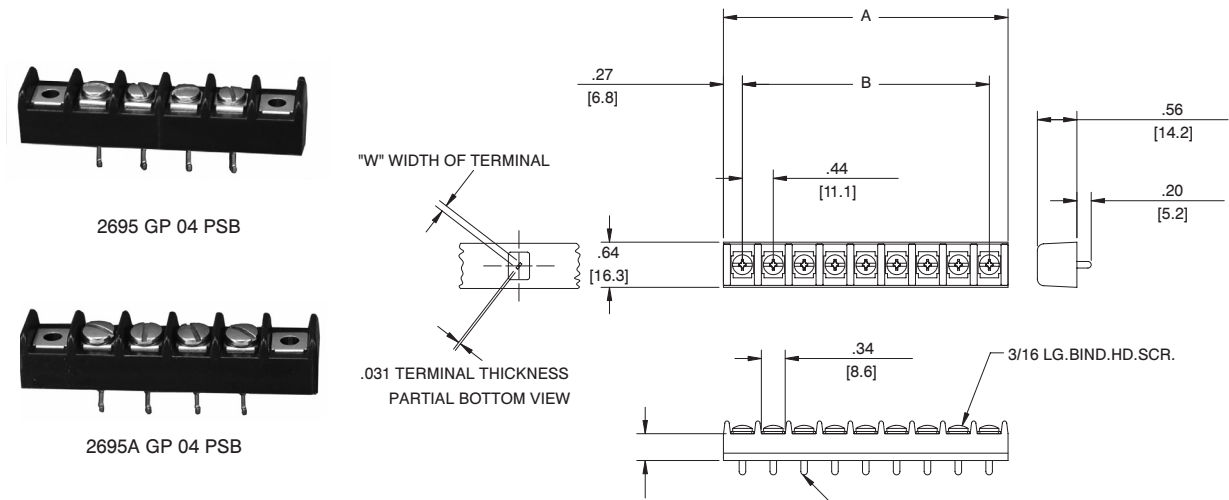

TERMINAL BLOCK SERIES: 2697 GP / 2698 GP / 2699 GP 2697A GP / 2698A GP / 2699A GP

DEFINITION BARRIER ENDS:

2697 GP	#6-32 Brass Screw, Printed Circuit Width = .062	2697A GP	#8-32 Brass Screw, Printed Circuit Width = .062
2698 GP	#6-32 Brass Screw, Solder Turret (not shown)	2698A GP	#8-32 Brass Screw, Solder Turret (not shown)
2699 GP	#6-32 Brass Screw, Printed Circuit Width = .093	2699A GP	#8-32 Brass Screw, Printed Circuit Width = .093

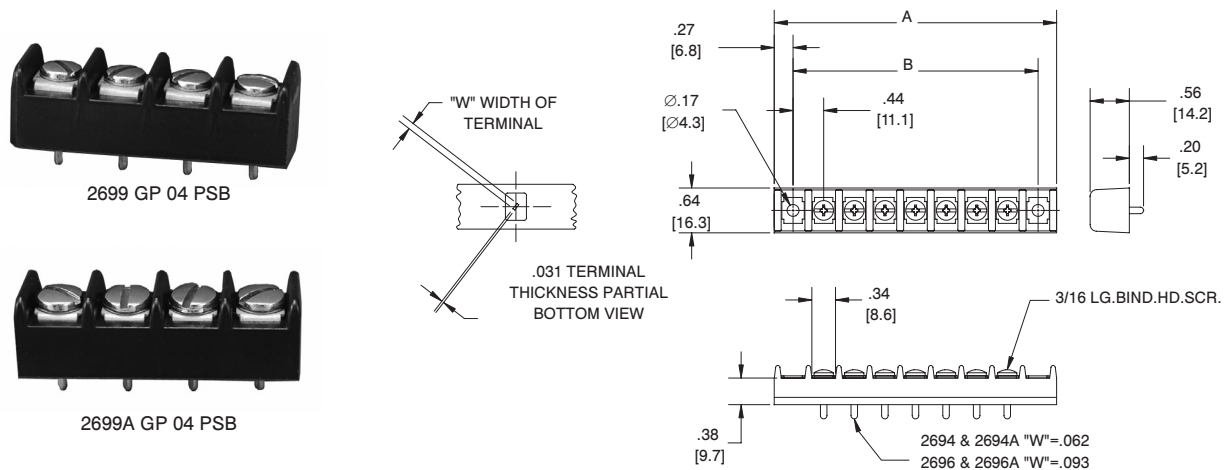

For electronic drawings or 2D/3D CAD data,
send request to drawings@marathonsp.com

Datasheets available at marathonsp.com

Terminal Block Accessories

Kliptite (Quick Connect) - Single Row

Specifications:

Kliptite (Quick Connect) accept standard female wire terminals. These Kliptites are ideal for applications that require a positive, yet quick disconnect termination. Kliptites are assembled to the block with screws or, in some applications, riveted to the block.

Kliptites are available in 0°, 45° or 90° bends; one side or two side. Material: Brass; Finish: Tin

Screw Construction	Rivet Construction	Tab Width	Tab Thickness	(2) 0° tabs	(2) 45° tabs	(2) 90° tabs	(1) 0° tab	(1) 45° tab	(1) 90° tab
411 Series		0.110	0.020	KT10	KT11	KT12	KT16	KT17	KT18
599 Series	799 Series	0.187	0.020	KT28	KT29	KT30	KT34	KT35	KT36
699 Series	899 Series	0.250	0.032	KT46	KT47	KT48	KT52	KT53	KT54
812 Series	912 Series	0.250	0.032	KT73	KT74	KT75	KT79	KT80	KT81
1690 Series ¹		0.250	0.032	KT46	KT47	KT48	KT52	KT53	KT54
2590 Series ²		0.187	0.020	KT28	KT29	KT30	KT34	KT35	KT36
2690 Series ³		0.250	0.032	KT46	KT47	KT48	KT52	KT53	KT54

- 1) 1690 Series insulated feed-thru blocks use the 699 Series Kliptites
- 2) 2590 Series use the 599 Series Kliptites
- 3) 2690 Series PC block use the 699 Kliptites

For electronic drawings or 2D/3D CAD data, send request to drawings@marathonsp.com

TWO SIDE TABS

ONE SIDE TABS

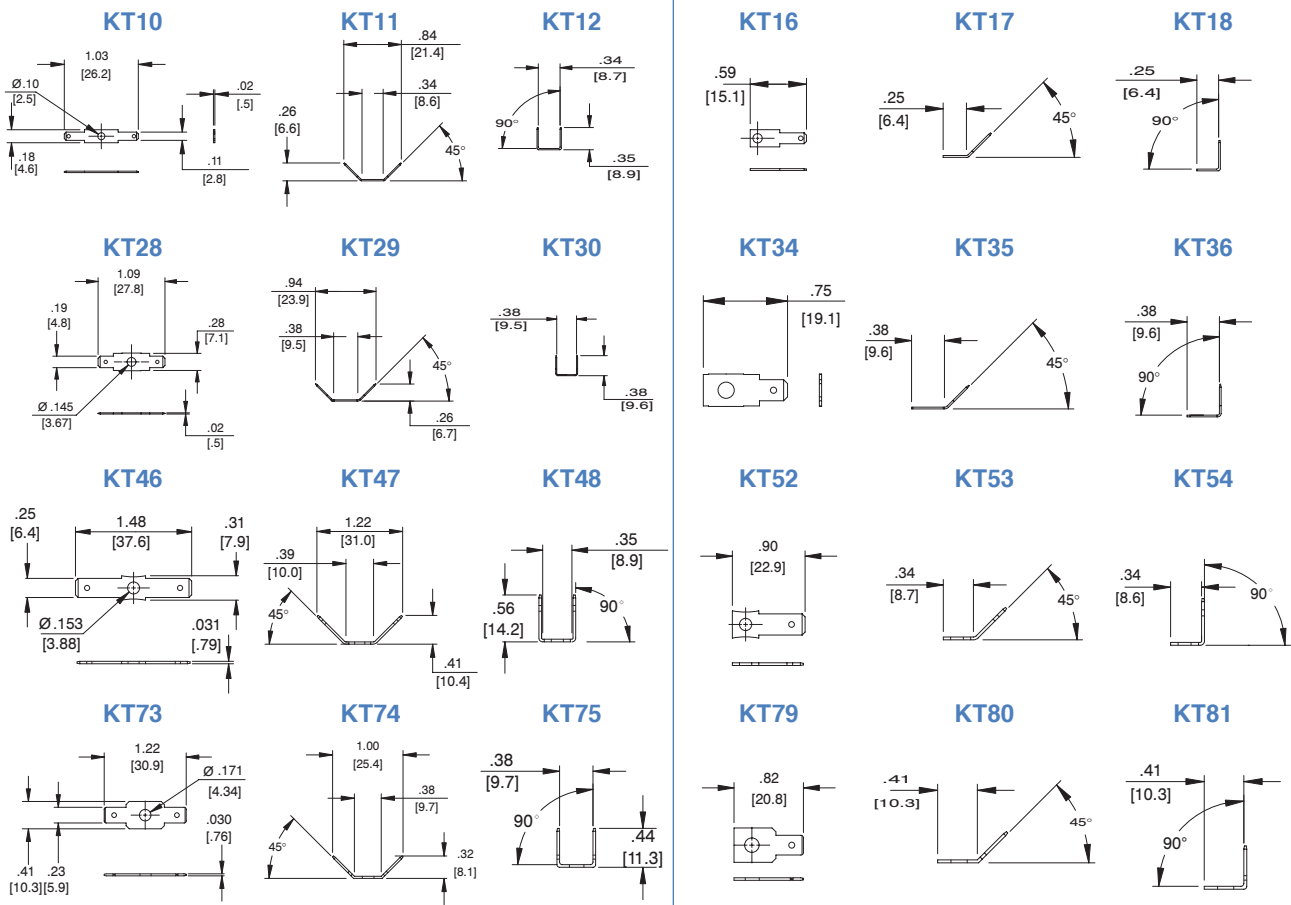

Terminal Block Accessories

Kliptite (Quick Connect) - Double Row

Screw Construction	Rivet Construction	Tab Width	Tab Thickness	(2) 0° tabs	(2) 45° tabs	(2) 90° tabs	(1) 0° tab	(1) 45° tab	(1) 90° tab
100 Series ⁴		0.187	0.020	KT19	KT20	KT21	KT25	KT26	KT27
200 Series ⁵		0.250	0.032	KT37	KT38	KT39	KT43	KT44	KT45
200HB Series ⁵		0.250	0.032	KT37	KT38	KT39	KT43	KT44	KT45
300 Series ⁶		0.250	0.032	KT55	KT56	KT57	KT61	KT62	KT63
400 Series		0.250	0.032	KT67	KT68	KT69	KT64	KT65	KT66
600 Series		0.187	0.020	KT19	KT20	KT21	KT25	KT26	KT27
600A Series	800A Series	0.187	0.020	KT19	KT20	KT21	KT25	KT26	KT27
601 Series	801 Series	0.250	0.032	KT37	KT38	KT39	KT43	KT44	KT45
602 Series	802 Series	0.250	0.032	KT55	KT56	KT57	KT61	KT62	KT63
603 Series		0.250	0.032	KT67	KT68	KT69	KT64	KT65	KT66
621 RZ Series ⁵		0.250	0.032	KT37	KT38	KT39	KT43	KT44	KT45
670A GP Series ⁴		0.187	0.020	KT19	KT20	KT21	KT25	KT26	KT27
670A RZ Series ⁴		0.187	0.020	KT19	KT20	KT21	KT25	KT26	KT27
671 GP Series ⁵		0.250	0.032	KT37	KT38	KT39	KT43	KT44	KT45
671 RZ Series ⁵		0.250	0.032	KT37	KT38	KT39	KT43	KT44	KT45
672 GP Series ⁶		0.250	0.032	KT55	KT56	KT57	KT61	KT62	KT63
672 RZ Series ⁶		0.250	0.032	KT55	KT56	KT57	KT61	KT62	KT63

- 4) 100, 670A GP, 670A RZ Series use the 600, 600A Series Kliptites
 5) 200, 671 GP, 671 RZ, 200HB, 621 RZ Series use the 601 Series Kliptites
 6) 300, 672 GP, 672 RZ Series use the 602 Series Kliptites

- MSP Catalog Designations:
 2-SIDE TABS: F1 (0°), F2 (45°), F3 (90°)
 1-SIDE TABS: HF1 (0°), HF2 (45°), HF3 (90°)

For electronic drawings or 2D/3D CAD data, send request to drawings@marathonsp.com

TWO SIDE TABS

ONE SIDE TABS

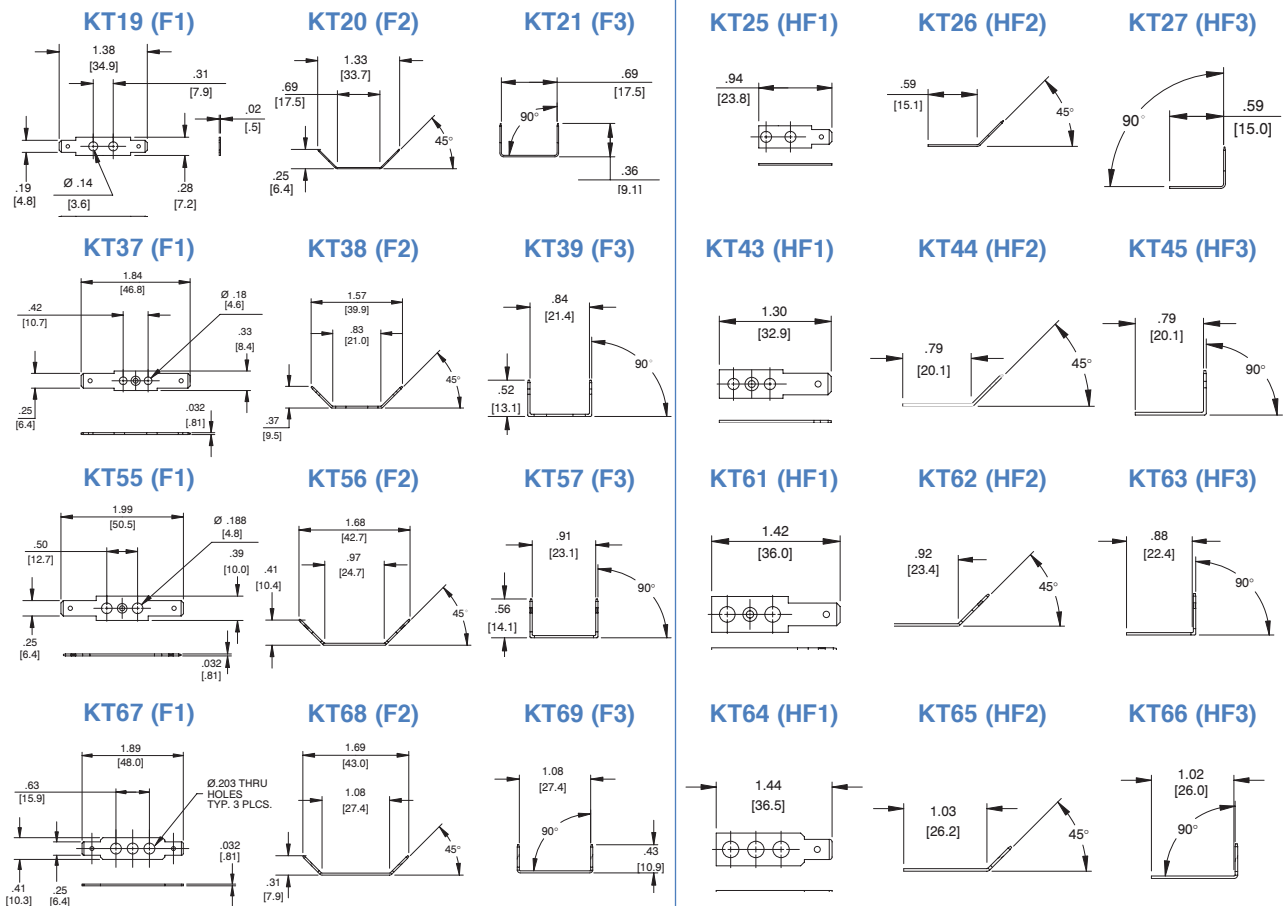

Terminal Block Accessories

Solder Terminal Lugs

ST and 3/4 ST Types

	FIGURE	A	B	C	D	E	F	G	H	J	M	N	R	T	ALSO USED ON
411 ST	SEE FIGURE #1														
411 3/4ST	SEE FIGURE #1A														
599 3/4ST	FIG 2	0.56	--	--	--	0.28	0.16	0.06	0.16	0.032	0.144	0.093	0.11	--	2590, 2590A
600 ST	FIG 3	1.22	0.75	0.69	0.31	0.28	0.16	0.06	0.16	0.032	0.144	0.093	--	--	600A, 670A GP
600 3/4ST	FIG 3A	0.92	--	--	0.31	0.28	0.16	0.06	0.16	0.032	0.144	0.093	0.15	--	
601 ST	FIG 3	1.58	0.94	0.84	0.42	0.31	0.21	0.06	0.21	0.036	0.148	0.125	--	--	200HB, 621 RZ
601 3/4ST	FIG 3A	1.17	--	--	0.42	0.31	0.21	0.06	0.21	0.036	0.148	0.125	0.17	--	
602 ST	FIG 3	1.85	1.06	0.94	0.50	0.41	0.28	0.09	0.28	0.036	0.177	0.125	--	--	672 GP
602 3/4ST	FIG 3A	1.37	--	--	0.50	0.41	0.28	0.09	0.28	0.036	0.177	0.125	0.20	--	
699 3/4ST	FIG 2	0.70	--	--	--	0.31	0.21	0.06	0.21	0.032	0.146	0.125	0.13	--	1690, 2690
812 3/4ST	FIG 2	0.88	--	--	--	0.41	0.28	0.09	0.28	0.037	0.177	0.125	0.19	--	

mm = dim x 25.4

MSP Catalog Designations: ST = S 3/4ST = HS

To ensure solderability, use within six (6) months.

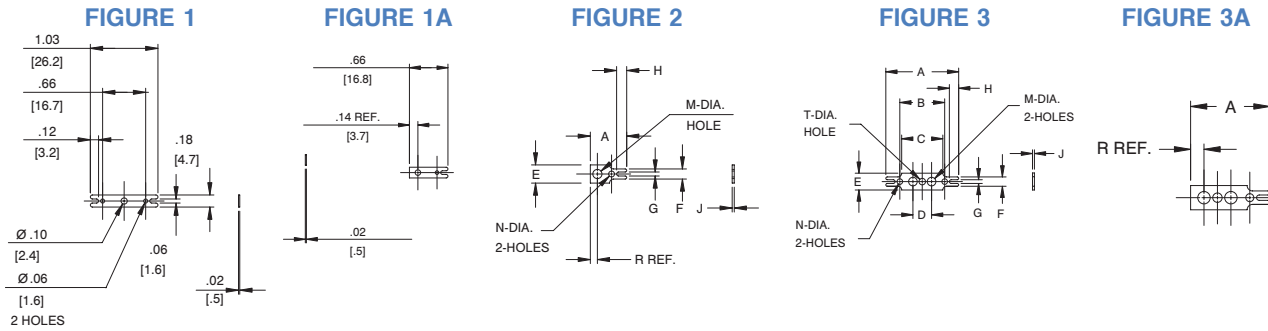

Y, YSY and Z Types (Material: Brass Finish Electro-Tin Plated)

	FIGURE	A	B	C	D	E	F	H	J	M	L (see detail R)	ALSO USED ON	
599Z, 600Y	FIG 6	0.28	0.48	0.33	0.085	0.63	0.036	NA	0.144	NA	599Z=0.31, 600Y=0.31	670A RZ	
600YSY	FIG 6	0.28	0.48	0.33	0.085	0.82	0.036	NA	0.144	NA	0.50	670A RZ	
600Z	FIG 7	0.28	0.73	0.25	0.140	0.94	0.036	0.31	0.160	0.143	0.62	670A RZ	
699Z, 601Y	FIG 4	0.31	0.63	0.44	0.099	0.80	0.036	NA	0.148	NA	699Z=0.42, 601Y=0.42		
601YSY	FIG 5	0.31	0.63	0.44	0.099	1.07	0.040	NA	0.148	NA	0.69		
602Y	FIG 4	0.43	0.75	0.52	0.125	0.95	0.040	NA	0.177	NA	0.49		
812Z, 602YSY	FIG 5	0.40	0.70	0.52	0.125	1.13	0.040	NA	0.177	NA	812Z=0.64, 602YSY=0.67		
602Z	FIG 8	0.40	1.09	0.38	0.203	1.06	0.040	0.50	0.177	NA	0.60		
603Y	FIG 9	NOTE: For factory assembly only onto 603 Terminal Boards										0.60	

mm = dim x 25.4

MSP Catalog Designations: Y = L YSY = LSL

To ensure solderability, use within six (6) months.

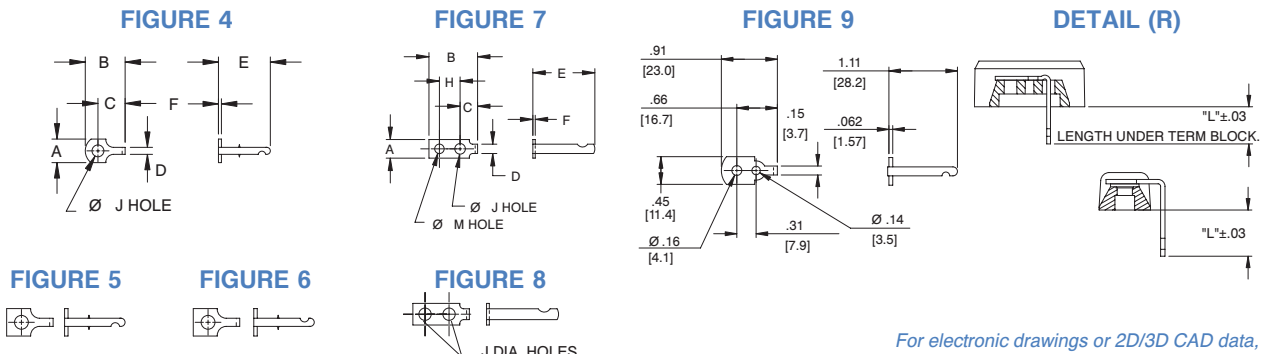

Figures 5 & 6 same as Figure 4 except as shown

Same as Figure 7 except as shown

For electronic drawings or 2D/3D CAD data, send request to drawings@marathonsp.com

Terminal Block Accessories

J & JS Jumpers

Catalog #	A	B	C	D	E	F	G	H	J	K
J 410/J 411	0.41	0.25	0.19	0.09	0.10	0.04	0.010	0.094	0.08	NA
J 600	0.62	0.38	0.25	0.12	0.16	0.04	0.015	0.156	0.08	NA
J 601	0.71	0.45	0.31	0.15	0.19	0.06	0.015	0.166	0.11	NA
J 602	0.91	0.56	0.37	0.18	0.27	0.08	0.015	0.190	0.16	NA
J 603	1.13	0.69	0.43	0.21	0.25	0.12	0.031	0.201	0.24	NA
J 604	1.38	0.88	0.50	0.25	0.35	0.15	0.035	0.234	0.32	NA
J 605	1.75	1.13	0.62	0.31	0.39	0.24	0.035	0.266	0.54	NA
JS 600	0.62	0.38	0.25	0.12	0.16	0.04	0.015	0.156	0.08	0.16
JS 601	0.71	0.45	0.31	0.15	0.19	0.06	0.015	0.166	0.11	0.17
JS 602	0.91	0.56	0.37	0.18	0.27	0.08	0.015	0.190	0.16	0.14
LL 200HB	0.69	0.44	0.30	0.17	0.38	0.07	0.015	0.141	0.11	0.14

MSP Catalog Designations:
 J 600 = LL 100
 J 601 = LL 200
 J 602 = LL 300
 J 603 = LL 400

Material: Brass
 Finish: Nickel Plate

mm = dim X 25.4

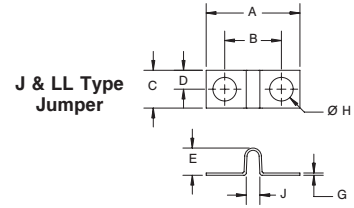

J & LL Type Jumper
 (per 55164/28B)

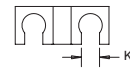

NOTE 1: These parts are not necessarily supplied flat. The functioning of the part, however, will not be interfered.

NOTE 2: All dimensions are applicable after the bus (jumper) is torqued down into the associate terminal board.

RJ Type Jumpers

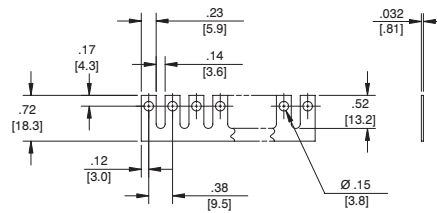

600 RJ
 Max # of sections = 24

Note: 670A RZ, 599 Series, use 600 RJ

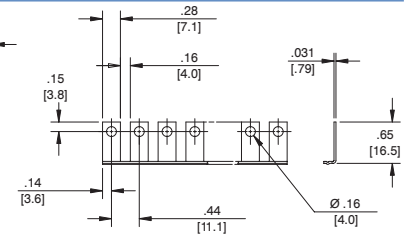

601 RJ
 Max # of sections = 24

Material: Brass
 Finish: Nickel Plate

RJS Type Jumpers

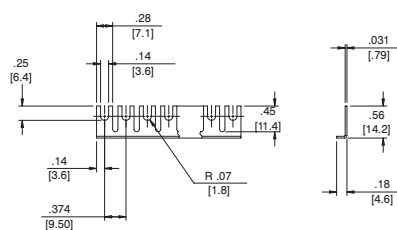

600 RJS
 Max # of sections = 24

Note: 670A RZ, 599 Series, use 600 RJ

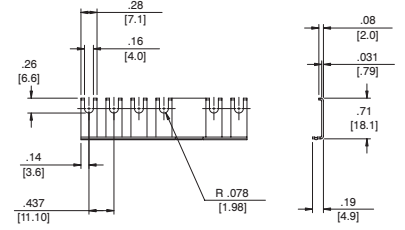

601 RJS
 Max # of sections = 24

Material: Brass
 Finish: Nickel Plate

Wire Clamp

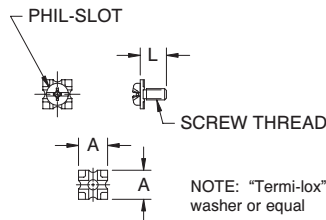

NOTE: "Termi-lox" washer or equal

Catalog #	Material	Finish	Screw Thread	L	A
3786	Steel	Nickel	8-32 UNC	0.38	0.41
3765			6-32 UNC	0.31	0.33
3780	Brass	Nickel	8-32 UNC	0.38	0.41
3760			6-32 UNC	0.31	0.33
3860	Brass	Nickel	6-32 UNC	0.30	0.29
3865	Steel	Nickel	6-32 UNC	0.30	0.29

mm = dim X 25.4

Straddle Plate

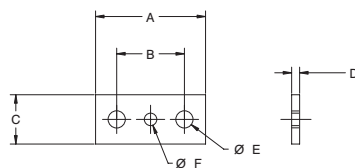

Catalog #	A	B	C	D	E	F	Material	Finish
SPB 600	0.56	0.31	0.30	0.032	0.144	N/A	Brass	Tin
SPB 601	0.71	0.42	0.30	0.031	0.148	N/A	Brass	Nickel
SPB 602	0.87	0.50	0.40	0.032	0.189	N/A	Brass	Nickel
SPB 603	1.03	0.62	0.45	0.063	0.190	0.143	Brass	Tin
SPB 604	1.21	0.75	0.54	0.087	0.187	0.138	Brass	Tin
SPB 605	1.46	0.87	0.63	0.116	0.220	0.138	Brass	Nickel

mm = dim X 25.4

For electronic drawings or 2D/3D CAD data, send request to drawings@marathonsp.com

Terminal Block Accessories

Kulka® Fanning Strips

- Terminals, Brass, Tin Plated
- Material: XP = Phenolic, Black
GME = Glass Cloth Melamine,
Per MIL-M-14 Light Brown Term

649 Series

- For 410 and 411 Series Terminal Blocks
- Available in XP Phenolic Only

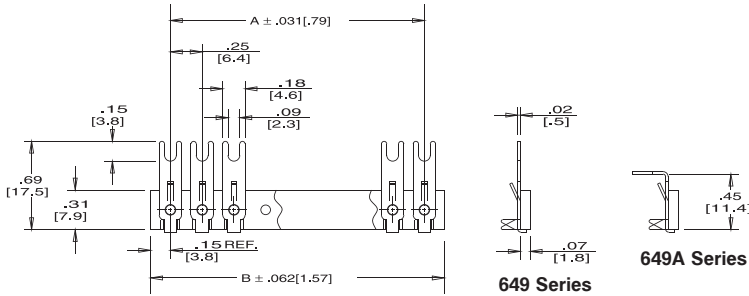

# of Term.	A	B	# of Term.	A	B
2	0.250	0.562	13	3.000	3.312
3	0.500	0.812	14	3.250	3.562
4	0.750	1.062	15	3.500	3.812
5	1.000	1.312	16	3.750	4.062
6	1.250	1.562	17	4.000	4.312
7	1.500	1.812	18	4.250	4.562
8	1.750	2.062	19	4.500	4.812
9	2.000	2.312	20	4.750	5.062
10	2.250	2.562	21	5.000	5.312
11	2.500	2.812	22	5.250	5.562
12	2.750	3.062			

650/651/652 Series

- 650 Series for 599, 600, and 670A RZ Series Terminal Blocks
- 651 Series for 601 and 699 Series Terminal Blocks
- 652 Series for 602 and 812 Series Terminal Blocks

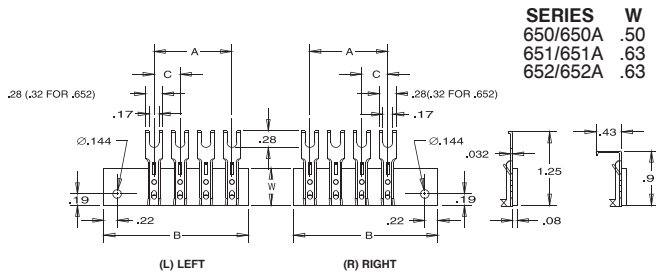

SERIES	650 / 650A		651 / 651A		652 / 652A	
C	3/8 (.375)		7/16 (.4375)		9/16 (.5625)	
# of Term.	A	B	A	B	A	B
2	.375	1.435	.437	1.497	.562	1.622
3	.750	1.810	.875	1.935	1.125	2.185
4	1.125	2.185	1.312	2.372	1.687	2.747
5	1.500	2.560	1.750	2.610	2.250	3.310
6	1.875	2.935	2.187	3.247	2.812	3.872
7	2.250	3.310	2.625	3.685	3.375	4.435
8	2.265	3.685	3.062	4.122	3.937	4.997
9	3.000	4.060	3.500	4.560	4.500	5.560
10	3.375	4.435	3.937	4.997	5.062	6.122
11	3.750	4.810	4.375	5.435	5.625	6.685
12	4.125	5.165	4.812	5.872	6.187	7.247
13	4.500	5.560	5.250	6.310	6.750	7.810
14	4.875	5.935	5.687	6.747	7.312	8.372
15	5.250	6.310	6.125	7.185	7.875	8.935
16	5.625	6.685	6.562	7.622	8.437	9.497
17	6.000	7.060	7.000	8.060	9.000	10.060
18	6.375	7.435	7.437	8.497	9.562	10.622
19	6.750	7.810	7.875	8.935	10.125	11.185
20	7.125	8.186	8.312	9.372	10.687	11.747
21	7.500	8.560	8.750	9.810	11.250	12.310
22	7.875	8.935	9.187	10.247	11.812	12.872
23	--	--	9.625	10.685	12.375	13.435
24	--	--	--	--	12.937	13.997
25	--	--	--	--	13.500	14.560
26	--	--	--	--	14.062	15.122

Ordering Code

For convenience and accuracy in ordering, please specify catalog numbers as shown:

- For Marking Strips, use an "MS" prefix on the series
- For Insulator Strips, use an "IS" prefix on the series

Series	Mat. Code	Angle	# of Term
649	XP	A L	5

For electronic drawings or 2D/3D CAD data, send request to drawings@marathonsp.com

Terminal Block Accessories

Kulka® Stud and Turret Terminal Blocks

Threaded Stud

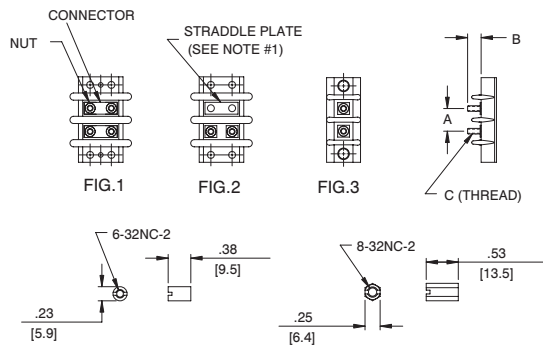

Catalog #	Figure	A	B	C
599 GP 2002 XX	FIG 3	0.38	0.34	6-32 NC
600A GP 2002 XX	FIG 2	0.38	0.38	6-32 NC
601 GP 2102 XX	FIG 2	0.44	0.44	6-32 NC
602 GP 2202 XX	FIG 2	0.56	0.50	8-32 NC
603 GP 2302 XX	FIG 1	0.69	0.50	10-32 NF
604 GP 2402 XX	FIG 1	0.88	0.44	10-32 NF
605 GP 2502 XX	FIG 1	1.13	0.75	1/4-28 NF
699 GP 2102 XX	FIG 3	0.44	0.44	6-32 NC
812 GP 2202 XX	FIG 3	0.56	0.50	8-32 NC

NOTE 1: Standard with block, but packed separately
 NOTE 2: 604 and 605 nuts are part of the assembly.
 Additional nuts (one per stud) are supplied in bulk.

XX = # of terminals

Screw Terminal with Feed-Thru Solder Terminal

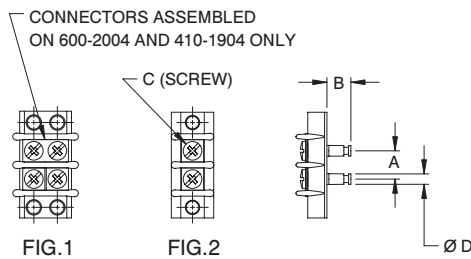

Catalog #	Figure	A	B	C	D
411 GP 1904 XX	FIG 2	0.25	0.28	2-56 NC X .19	0.11
599 GP 2004 XX	FIG 2	0.38	0.31	5-40 NC X .25	0.14
600 GP 2004 XX	FIG 1	0.38	0.31	5-40 NC X .25	0.14
601 GP 2104 XX	FIG 1	0.44	0.38	6-32 NC X .25	0.13
699 GP 2104 XX	FIG 2	0.44	0.38	6-32 NC X .25	0.13
812 GP 2204 XX	FIG 2	0.56	0.44	8-32 NC X .25	0.14

To ensure solderability, use within six (6) months. XX = # of terminals

Screw Terminal with Solder Pin for Printed Circuit Board Connection

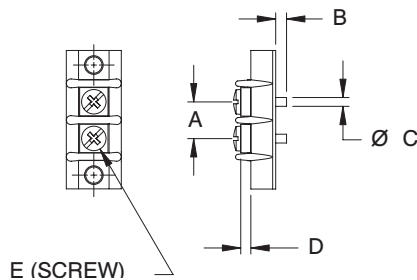

Catalog #	A	B	C	D	E
599 GP 2020 XX	0.38	0.13	0.09	0.09	5-40 NC X .19
599 GP 2021 XX	0.38	0.13	0.09	0.03	5-40 NC X .19
699 GP 2120 XX	0.44	0.19	0.09	0.04	6-32 NC X .25
699 GP 2121 XX	0.44	0.20	0.06	0.04	6-32 NC X .25

To ensure solderability, use within six (6) months. XX = # of terminals

Individual Screw Terminals

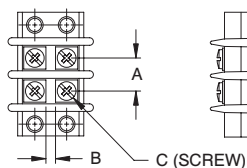

Catalog #	A	B	C
601 GP 2108 XX	0.44	0.09	6-32 NC X .25

XX = # of terminals

For electronic drawings or 2D/3D CAD data,
 send request to drawings@marathonsp.com

Datasheets available at marathonsp.com

Terminal Block Accessories

Double Row - Top Mounted Covers/Marking Strips

Specifications:

- White Vinyl Material
- Two Nylon Spring Clips for Mounting Provided
- **Marking Strips:** Printed on Center Line with Letters or Numbers for Circuit Identification
- **Covers:** Printed on Top, Bottom or Center Line with Letters or Numbers for Circuit Identification
- Printing Character Size is 1/8 Inch
- Unless Otherwise Specified, the Marking goes down the Center of the Cover for Print Styles 01A, 01B, 01C, 01D
- Marking goes down the 2 Sides of the Cover for Print Styles 07A, 07B, 07C, 07D

Number of Terminals	Series 1		Series 2		Series 3	
	A	B	A	B	A	B
1	0.91	0.55	1.01	0.65	1.16	0.80
2	1.29	0.93	1.44	1.08	1.73	1.37
3	1.66	1.30	1.88	1.52	2.29	1.93
4	2.04	1.68	2.32	1.96	2.85	2.49
5	2.41	2.05	2.76	2.40	3.42	3.06
6	2.79	2.43	3.19	2.83	3.98	3.62
7	3.16	2.80	3.63	3.27	4.54	4.18
8	3.56	3.20	4.07	3.71	5.10	4.74
9	3.91	3.55	4.50	4.14	5.67	5.31
10	4.29	3.93	4.94	4.58	6.23	5.87
11	4.66	4.30	5.38	5.02	6.79	6.43
12	5.04	4.68	5.81	5.45	7.36	7.00
13	5.41	5.05	6.25	5.89	7.92	7.56
14	5.79	5.43	6.69	6.33	8.48	8.12
15	6.16	5.80	7.13	6.77	9.05	8.69
16	6.54	6.18	7.56	7.20	9.61	9.25
17	6.91	6.55	8.00	7.64	10.17	9.81
18	7.29	6.93	8.44	8.08	10.73	10.37
19	7.66	7.30	8.87	8.51	11.30	10.94
20	8.04	7.68	9.31	8.95	11.86	11.50
21	8.41	8.05	9.75	9.39	12.42	12.06
22	8.79	8.43	10.18	9.82	12.99	12.63
23	9.16	8.80	10.62	10.26	13.55	13.19
24	9.54	9.18	11.06	10.70	14.11	13.75
25	9.91	9.55	11.50	11.14	--	--
26	10.29	9.93	11.93	11.57	--	--
27	10.66	10.30	12.37	12.01	--	--
28	11.04	10.68	12.81	12.45	--	--
29	11.41	11.05	13.24	12.88	--	--
30	11.79	11.43	13.68	13.32	--	--
31	12.16	11.80	--	--	--	--
32	12.54	12.18	--	--	--	--
33	12.91	12.55	--	--	--	--
34	13.29	12.93	--	--	--	--
35	13.66	13.30	--	--	--	--
36	14.04	13.68	--	--	--	--

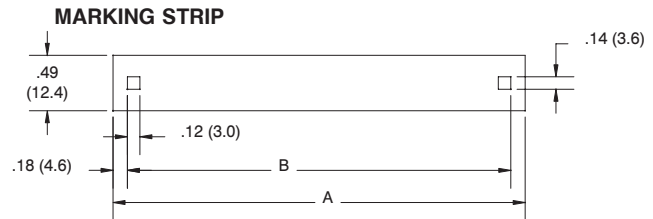
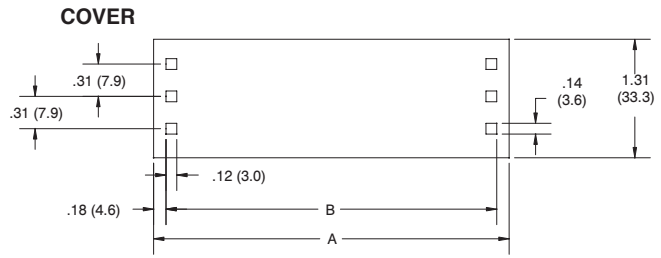

Print Styles

01A	1 2 3 4 5 6 7	01C	1 2 3 4 5 6 7
01B	7 6 5 4 3 2 1	01D	7 6 5 4 3 2 1
07A	7 6 5 4 3 2 1 1 2 3 4 5 6 7	07C	1 2 3 3 4 4 5 5 6 7 1 2 3 3 4 4 5 5 6 7
07B	1 2 3 4 5 6 7 7 6 5 4 3 2 1	07D	7 6 5 5 4 4 3 3 2 1 7 6 5 5 4 4 3 3 2 1

Ordering Codes

COVER	SERIES	NO. OF TERMINALS	PRINT STYLE
CW	2	05*	01A
CB (Black) CW (White)		*Add HB if using 200HB Terminal Block	
MARKING STRIP	SERIES	NO. OF TERMINALS	PRINT STYLE
SW	2	05*	01A
SW (White)		*Add HB if using 200HB Terminal Block	

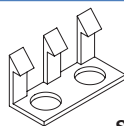

NYLON SPRING CLIP

For electronic drawings or 2D/3D CAD data, send request to drawings@marathonsp.com

Terminal Block Accessories

Double Row - Sub Mounted Marking Strips

Specifications:

- Black XP Phenolic Material
- Printed on Top or Bottom Position with Letters or Numbers for Circuit Identification
- Printing Character Size is 1/8 Inch

# of Terminals	Series 1	Series 2	Series 3
	100/670A GP, 600 GP, 600A GP, 670A RZ	200/671 GP, 200HB, 601 GP, 621 RZ, 671 RZ	300/672 GP, 602 GP, 672 RZ
1	1.031	1.188	1.531
2	1.406	1.625	2.094
3	1.781	2.063	2.656
4	2.156	2.500	3.219
5	2.531	2.938	3.781
6	2.906	3.375	4.344
7	3.281	3.813	4.906
8	3.656	4.250	5.469
9	4.031	4.688	6.031
10	4.406	5.125	6.594
11	4.781	5.563	7.156
12	5.156	6.000	7.719
13	5.531	6.438	8.281
14	5.906	6.875	8.844
15	6.281	7.313	9.406
16	6.656	7.750	9.969
17	7.031	8.188	10.531
18	7.406	8.625	11.094
19	7.781	9.063	11.656
20	8.156	9.500	12.219
21	8.531	9.938	12.781
22	8.906	10.375	13.344
23	9.281	10.813	13.906
24	9.656	11.250	14.469
25	10.031	11.688	--
26	10.406	12.125	--
27	10.781	12.563	--
28	11.156	13.000	--
29	11.531	13.438	--
30	11.906	13.875	--
31	12.281	--	--
32	12.656	--	--
33	13.031	--	--
34	13.406	--	--
35	13.781	--	--
36	14.156	--	--

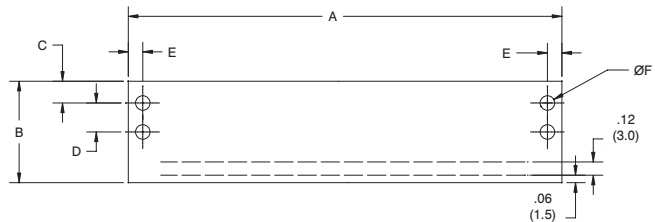

SERIES	B	C	D	E	F
100	1.12	.28	.31	.14	.16
200	1.37	.34	.42	.16	.18
200HB	1.88	.51	.42	.16	.18
300	1.56	.40	.50	.20	.20

Print Styles

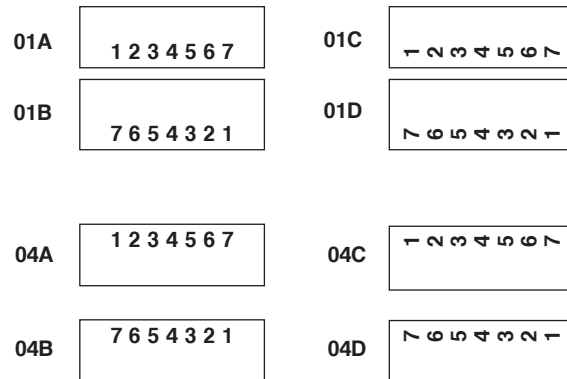

Ordering Code

SUB MOUNTED (BLACK)	SERIES	NO. OF TERMINALS	PRINT STYLE
FB	3	12	01A

For electronic drawings or 2D/3D CAD data, send request to drawings@marathonsp.com

Marking and Insulator Strips

Kulka® marking strips serve as insulation between terminal blocks and chassis, as well as providing a marking surface for terminal identification. When specified, they can be printed to show terminal designations by numbers, letters, symbols or any combination thereof. Insulator strips offer the same properties, but do not provide space for terminal identification. Both marking and insulator strips can be supplied pre-mounted on the back of each block thereby simplifying assembly and inventory control.

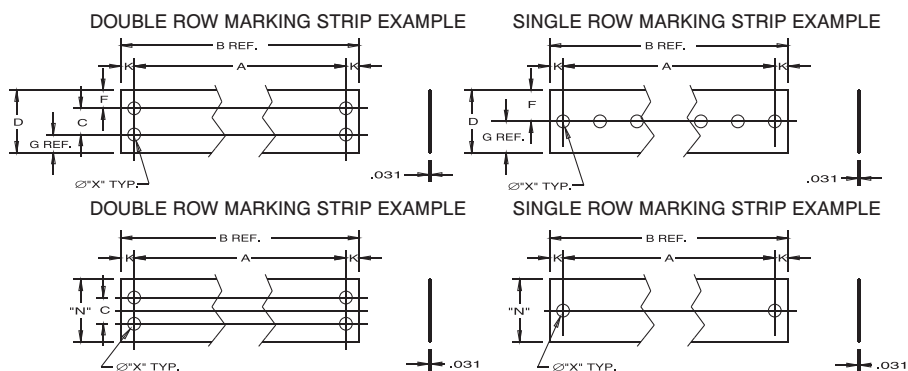

Drawing and Dimensions:

Marking and insulator strips are available for Kulka® Terminal Blocks. These include double and single row/single row insulated turret.

Dimensions for insulator strips do not allow a marking surface.

Order Information:

FEED-THRU STYLE: For feed-thru terminal blocks, see styles 2, 3, 5, 6, 8, & 9 on page 110. Insert applicable feed-thru style designation in ordering code, i.e. Y, YSY, XY, 1904, 1921, 2000, 2004, 2020, 2021, 2104, 2120, 3000.

AVAILABILITY: Marking and insulator strips are available to fit most Kulka® Terminal Blocks. See SERIES reference numbers on pages 109 and 110 for a complete listing. If not listed, consult Customer Service for availability. Designate appropriate prefix (MS for marking strips or IS for insulator strip) in front of the SERIES number when ordering. Available materials: XP (general purpose laminate), XXXPFR (flame retardant), GME (glass cloth melamine), GEE (glass cloth epoxy).

Printing:

- Marking strips are available in many printing styles. The maximum number of characters per station is two (2).
- Please specify printing style.
- If unprinted marking strips are desired, insert the letter "X" in the printing style space of the ordering code.
- Printing is the standard method of marking.
- Printing color is silver (white) on dark surfaces and black on light surfaces.
PROTECTIVE COATING: Marking and insulator strips can be supplied with a fungus proof varnish (MIL-V-173A) cover coating. State on order: "coat after printing with MIL-V-173A varnish."

*See block dimension for overall length and mounting

Ordering Code:

Contact Customer Service for Availability of Materials

MS/IS	SERIES	MAT. CODE	FEED THRU (IF APPLICABLE)	NO. OF TERM	PRINT STYLE
MS	601	XP	Y	16	06A

Terminal Block Accessories

Marking Strip Dimensions - Single Row

Series	Style	Dimensions						
		D	F	G	K	W	X	N*
411	1, 2, 4	0.56	0.19	0.37	0.13	0.06	0.13	0.41
	5, 7, 8	0.88	0.44	--				
599 (799)	1, 2, 4	0.81	0.28	0.53	0.14	0.13	0.16	0.56
	5, 7, 8	1.13	0.56	--				
699 (899)	1, 2, 4	0.88	0.34	0.54	0.16	0.13	0.18	0.50
	5, 7, 8	1.13	0.56	--				
812 (912)	1, 2, 4	0.94	0.38	0.56	0.20	0.06	0.21	0.75
	5, 7, 8	1.31	0.66	--		0.13		

*N dimension to replace D dimension for insulator strips

mm = dim X 25.4

**Consult Customer Service on marking strips that are for terminal blocks with Z lugs.

For overall lengths, reference appropriate terminal block series A & B dimensions

STYLES 1 & 2

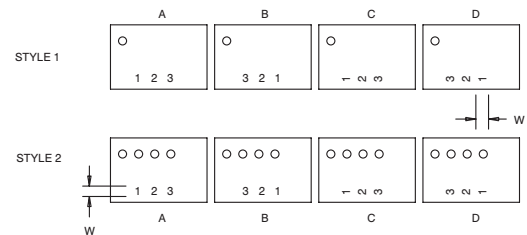
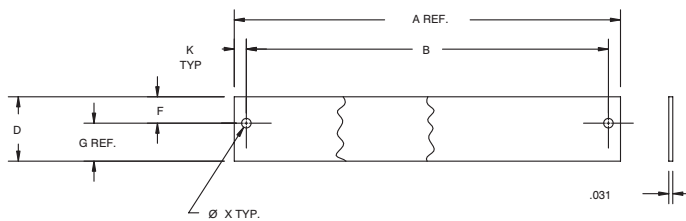

STYLES 4 & 5

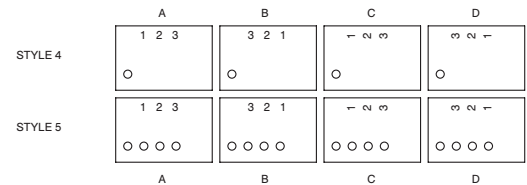
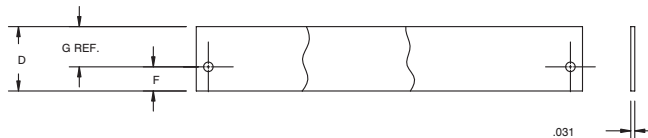

STYLES 7 & 8

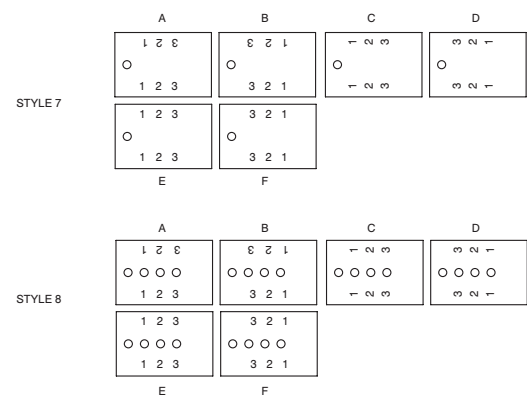
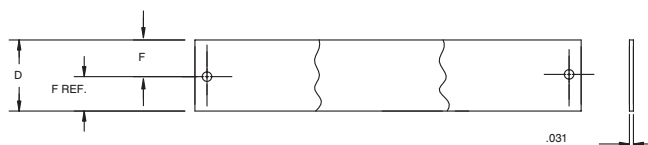

For electronic drawings or 2D/3D CAD data, send request to drawings@marathonsp.com

Terminal Block Accessories

Marking Strip Dimensions - Double Row

Series	Style	Dimensions							
		C	D	F	G	K	W	X	N*
410	1-6	0.25	0.75	0.19	0.31	0.12	0.06	0.13	0.41
	7, 8, 9		1.13	0.44	--				
600 (800)	1-6	0.31	1.13	0.28	0.53	0.14	0.13	0.16	0.69
	7, 8, 9		1.38	0.53	--				
601 (801)	1-6	0.42	1.31	0.34	0.55	0.16	0.13	1.75	0.88
	7, 8, 9		1.50	0.55	--				
602 (802)	1-6	0.50	1.50	0.41	0.59	0.20	0.13	0.21	1.06
	7, 8, 9		1.75	0.63	--				
603	1-6	0.63	1.88	0.59	0.66	0.22	0.13	0.23	1.31
	7, 8, 9		2.13	0.75	--				
604	1, 4	0.75	2.13	0.63	0.75	0.27	0.13	0.23	1.50
	7		2.50	0.88	--				
605	1, 4	0.88	2.69	0.81	1.00	0.31	0.13	0.27	1.81
	7		2.81	0.97	--				
670	1-6	0.31	1.19	0.28	0.60	0.14	0.13	0.16	0.88
	7, 8, 9		1.50	0.59	--				
671	1-6	0.42	1.50	0.34	0.73	0.16	0.13	0.18	1.13
	7, 8, 9		1.75	0.67	--				
672	1-6	0.50	1.63	0.41	0.72	0.20	0.13	0.21	1.31
	7, 8, 9		1.94	0.72	--				

*N dimension to replace D dimension for insulator strips
 **Consult Customer Service on marking strips that are for terminal blocks with Z lugs.

For overall lengths, reference appropriate terminal block series A & B dimensions

mm = dim X 25.4

STYLES 1, 2 AND 3

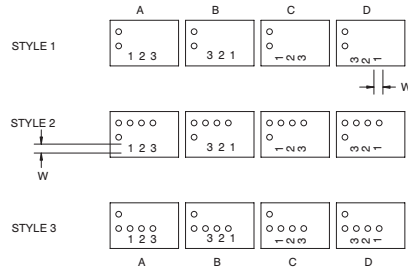
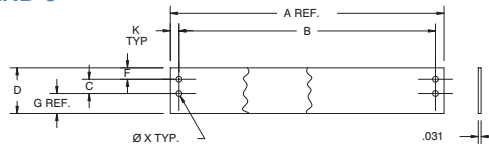

STYLES 4, 5 AND 6

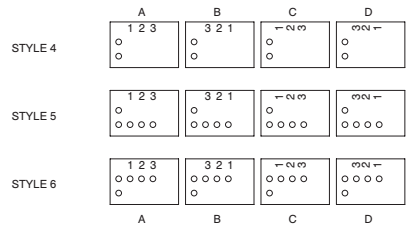
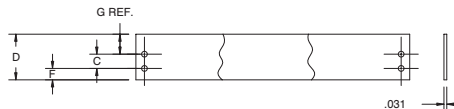

STYLE 7

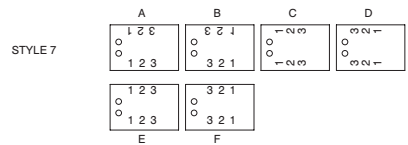
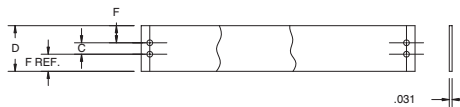

STYLES 8 AND 9

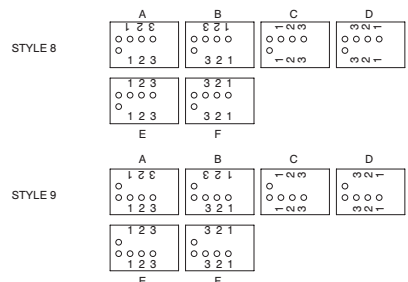
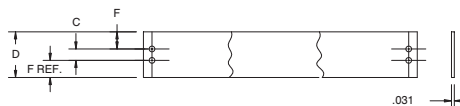

For electronic drawings or 2D/3D CAD data, send request to drawings@marathonsp.com

Terminal Block Accessories

Terminal Block Printing

Numeric Print Styles



Alpha Print Styles

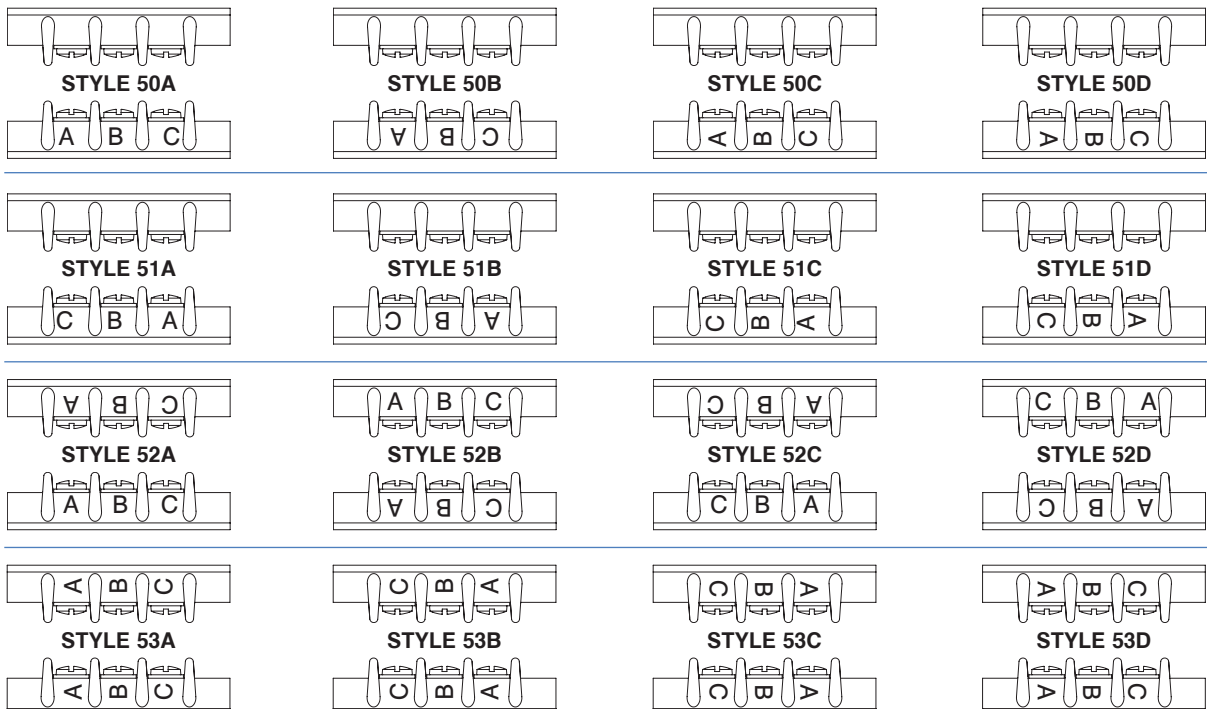

Sectional Terminal Blocks

General Information:

Sectionals are terminal blocks which are made up of individually molded units with electrically conductive members which, when assembled together, make up the block producing the required number of circuits. Marathon's DIN Sectional Blocks will fit on a standard 35mm DIN rail.

Marathon offers three sizes of sectional terminal blocks: 3/8" centers, 1/2" centers and 11/16" sectional fuse holders. All blocks can be ordered with a channel mount base, or a flat mount base for direct mounting to the panel. The 3/8" is also available with a DIN foot.

Ratings and Standards:

The voltage ratings of terminal blocks are based upon the minimum spacing between electrically conductive parts line to line through air and over surface and line to ground through air and over surface.

Class A

Service equipment including deadfront switchboards, panel boards, service entrance devices.

Class B

Commercial appliances including business equipment, electronic data processing equipment and the like.

Class C

General industrial and machine tool controls which can be further defined as equipment falling under UL 508.

Spacing Requirements*:

	Voltage	Thru Air	Over Surface
Class A	51-150	.500	.750
	151-300	.750	1.250
	301-600	1.000	2.000
Class B	51-150	.063	.063
	151-300	.094	.094
	301-600	.375	.500
Class C	51-150	.125	.250
	151-300	.250	.375
	301-600	.375	.500

*In Inches

Applications:

Designed for electrical termination of wire where flexibility of circuit design is necessary. Accepts single or multiple wire sizes for tubular screw and tubular clamp styles.

Sectional Terminal Blocks

3/8" Sectional Channel (C), Flat (F), & DIN Mount

600 Volts AC/DC
32 Circuits per Foot



6G38 TS F

Specifications:

- Meets IP20 Probing Requirement
- Wire Termination Torque 16 lb-in
- UL Recognized File No. XCFR2.E62806
- CSA Certified File No. LR19766
- **CE**
- RoHS Compliant

Tubular Screw Connector (6G38 TS)

Materials:

- Base - Gray Thermoplastic, 125°C (UL RTI)
- Tubular Screw Connector- Copper, Tin Plated
- Screw - #10-32 Steel, Nickel Plated

Wire Ranges:

- 50 Amps (40 Amps CSA)
- Single and Multiple Wire Combinations:

<u>Stranded CU</u>	<u>Solid CU</u>
(1) #8 - #18 AWG	(1) #10 - #16 AWG
(1-3) #12 AWG	(1-3) #12 AWG
(1-4) #14 AWG	(1-4) #14 or #16 AWG

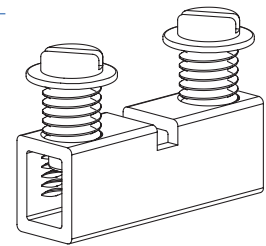

Ordering Code:

6G38 TS F	Flat mount block	Std pk 100	See Figure 2 On Page 115
6G38 TS C	Channel mount block	Std pk 100	See Figure 1 On Page 115
6G38 TS DIN	DIN mount block	Std pk 25	See Figure 3 On Page 115

Kant Kut Connector (6G38 TSKK)

Materials:

- Base - Gray Thermoplastic, 125°C (UL RTI)
- Kant Kut Connector- Copper, Tin Plated
- Screw - #10-32, Nickel Plated, Pad - Steel

Wire Ranges:

- 40 Amps
- Single and Multiple Wire Combinations:

<u>Stranded CU</u>	<u>Solid CU</u>
(1) #10-#22 AWG	(1) #10 - #14 AWG
(1-2) #12 AWG	(1-2) #12 or #14 AWG
(1-3) #14 AWG	
(1-4) #16 AWG	
(1-5) #18 or #22 AWG	

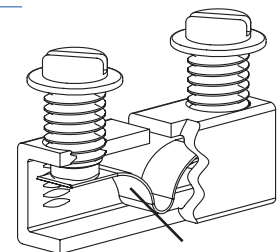

WIRE PROTECTOR

Ordering Code:

6G38 TSKK F	Flat mount block	Std pk 100	See Figure 2 On Page 115
6G38 TSKK C	Channel mount block	Std pk 100	See Figure 1 On Page 115
6G38 TSKK DIN	DIN mount block	Std pk 25	See Figure 3 On Page 115

For electronic drawings or 2D/3D CAD data,
send request to drawings@marathonsp.com

Sectional Terminal Blocks

Sems Pressure Connector (6H38 SP)

Materials:

- White Nylon, 105°C (UL RTI)
- Connector - Brass, Tin Plated
- Screw - #6-32 with Pad, Steel Nickel Plated

Wire Ranges:



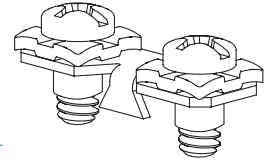



- 25 Amps
- (1) #12 - #22 AWG

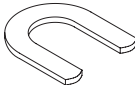
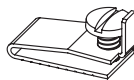

Ordering Code:

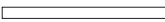
6H38 SP F	Flat mount block	Std pk 100	See Figure 2 On Page 115
6H38 SP C	Channel mount block	Std pk 100	See Figure 1 On Page 115
Not available with a DIN Mounted Base			

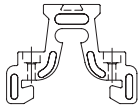
Sectional Terminal Block Accessories

Catalog #	Description		Std. Pack Qty.
J 38	Jumper for TS & TSKK		50
MC	Mounting Clamp (For channel style only)		25
MPC-3 (3 ft channel) MPC-6 (6 ft channel)	Channel		1
MS 2	Vinyl Marking Strip (1/2" x 2' white)		25
MN35-2	DIN Rail, 35 x 7.5 mm 2 m long, slotted		25
MSK35	End bracket for DIN mount base		25
6G38 E C 6G38 E F 6G38 E DIN	End sections for 6G38 versions		25
6H38 E F 6H38 E C	End sections for 6H38 versions		25

Sectional Terminal Blocks

Sectional Terminal Block Dimensions - 6G38 TS & TSKK

FIGURE 1:
Channel Mount

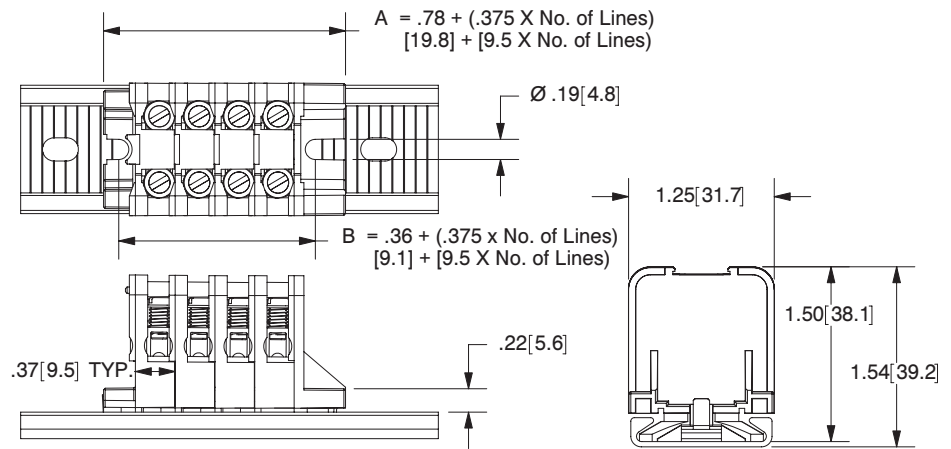

FIGURE 2:
Flat Mount

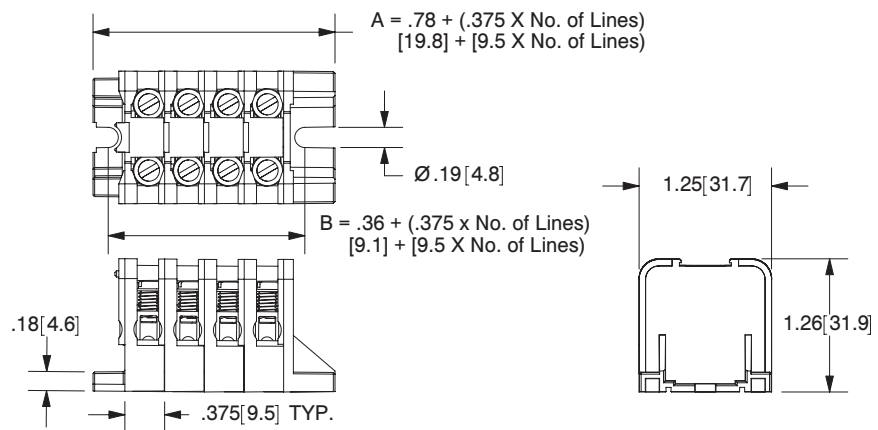
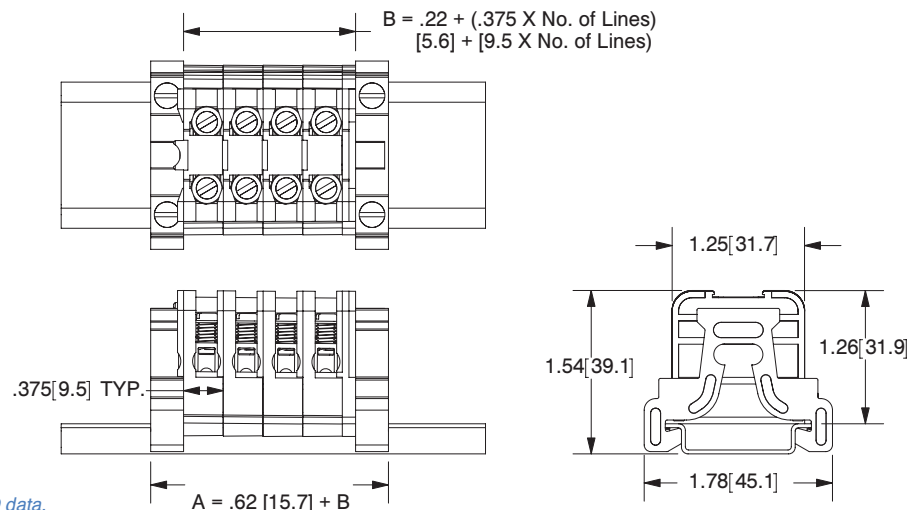

FIGURE 3:
DIN Mount



For electronic drawings or 2D/3D CAD data,
send request to drawings@marathonsp.com

Sectional Terminal Blocks

Sectional Terminal Block Dimensions - 6H38

FIGURE 4:

$$A = .79 + (.375 \times E)$$

$$B = .36 + (.375 \times E)$$

E = No. of Poles

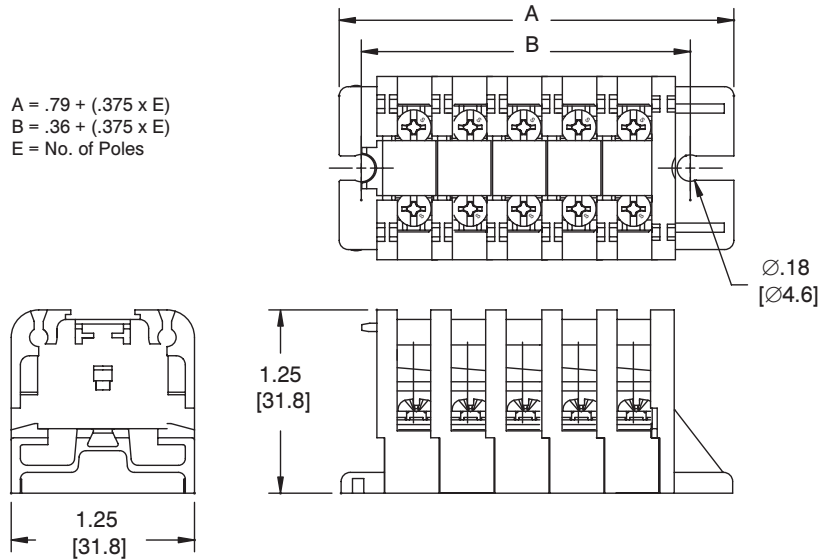
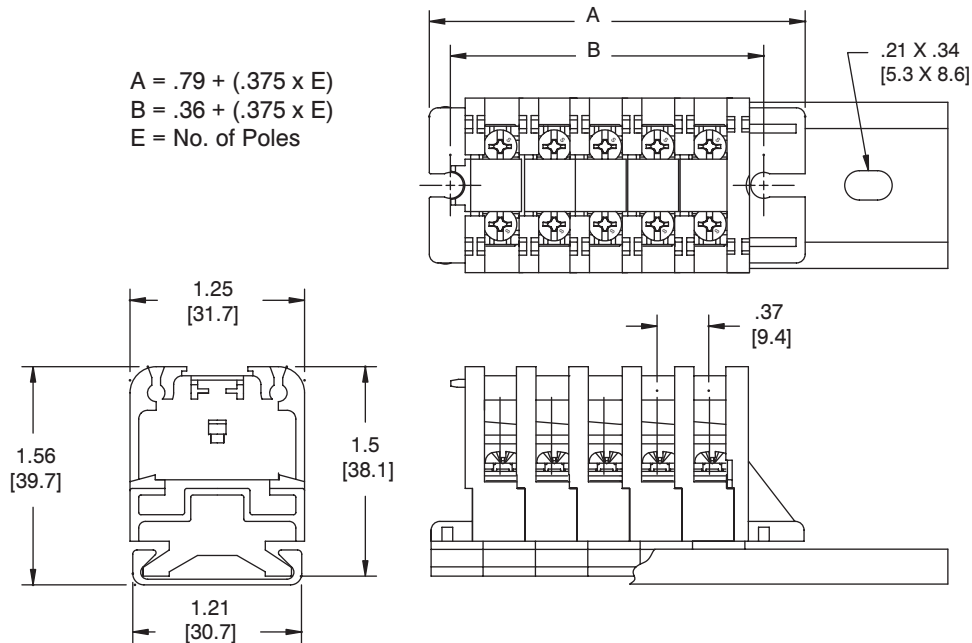

FIGURE 5:

$$A = .79 + (.375 \times E)$$

$$B = .36 + (.375 \times E)$$

E = No. of Poles



Sectional Terminal Blocks

1/2" Sectional





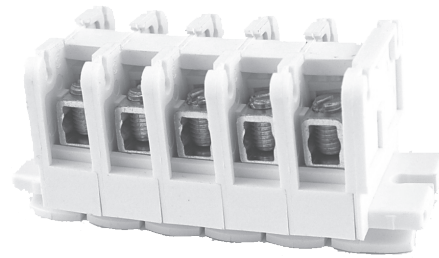

600 Volts AC/DC
24 Circuits per Foot

Specifications:

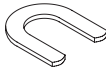
- Base, White Nylon - Type 6/6 105°C
- Tubular Screw (TSCU) Copper, Tin Plated; Screw #1/4-28 Steel, Nickel Plated
- Wire Range #4-#16 AWG Copper, 70 Amps
- Torque 20 lb-in
- UL Recognized File No. XCFR2.E62806
- CSA Certified File No. LR19766
- **CE**
- RoHS Compliant

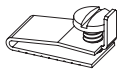

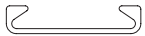
6H12 TSCU C

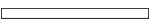
Catalog #	Description		Std Pk	Catalog #	Description		Std Pk
6H12 TSCU F For flat mount block	Tubular Screw		50	J 12	Jumper		50
6H12 TSCU C For channel mount block	Tubular Screw		50	MC	Mounting Clamp		25
6H12 E F For flat mount block	End Section		25	MPC-3 (3 ft channel) MPC-6 (6 ft channel)	Channel		--
6H12 E C For channel mount block	End Section		25	MS 2	Vinyl Marking Strip - 1/2" x 2'		25

Flat Mount:

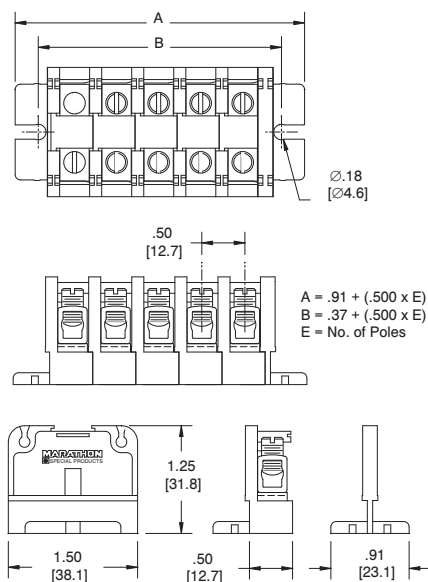

Channel Mount:

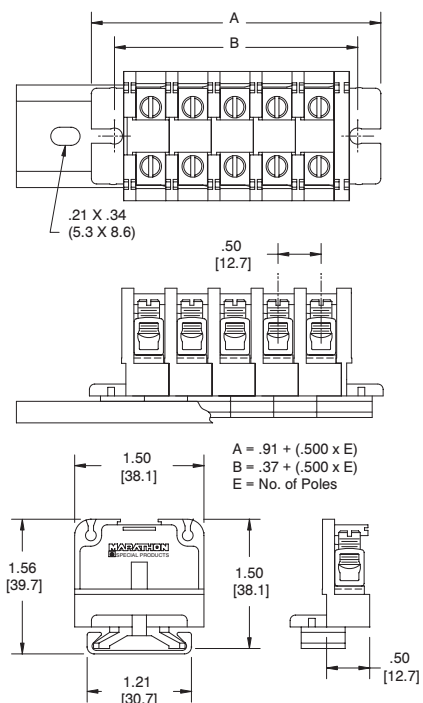

For electronic drawings or 2D/3D CAD data, send request to drawings@marathonsp.com

Datasheets available at marathonsp.com

Sectional Terminal Blocks

1 1/16" Sectional Fuse Holder 600 Volt, 30 Amp (Midget Fuse Holder)

Specifications:

- Tested and Approved for 10,000 Amp Withstand Rating
- Base, White Nylon - Type 6/6 105°C
- Connector Box Type
- Accepts up to #10 AWG Wire, either Terminated or Non-Terminated
- Clip, Copper Alloy, Tin Plated
- UL Recognized File No. IZLT2.E35113
- CSA Certified File No. LR21455
- **CE**
- RoHS Compliant

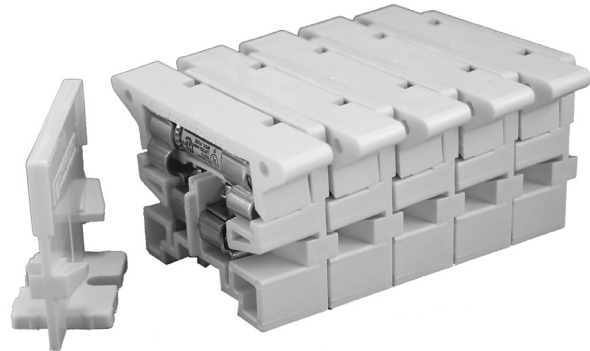

6W30A1F with end piece (fuse not included)

Standard	Description	Std Pack	Wire Range	Fuse Size	Fuses
6W30A1F	Flat Mount	10	#10-#14 AWG CU STRANDED	13/32" DIA BY 1 1/2" LONG	A13X-2, A25Z-2, A60Q-2, A6Y-2B, AGU, ATM, ATQ, BAF, BAN, BLF, BLN, BLS, FLA, FLM, FLQ, FNM, FNQ, GFN, GGO, KLK, KLKD, KLQ, KTK, OTM, TRM
6W30A1C	Channel Mount				
6WEF	End Piece (flat)				
6WEC	End Piece (channel)				
MC	Mounting Clamp	25			
MPC-6	6 Foot Channel	-			
MPC-3	3 Foot Channel				
GR-2	1/8" Diameter X 2' Long Nylon Rod				

For electronic drawings or 2D/3D CAD data, send request to drawings@marathonsp.com

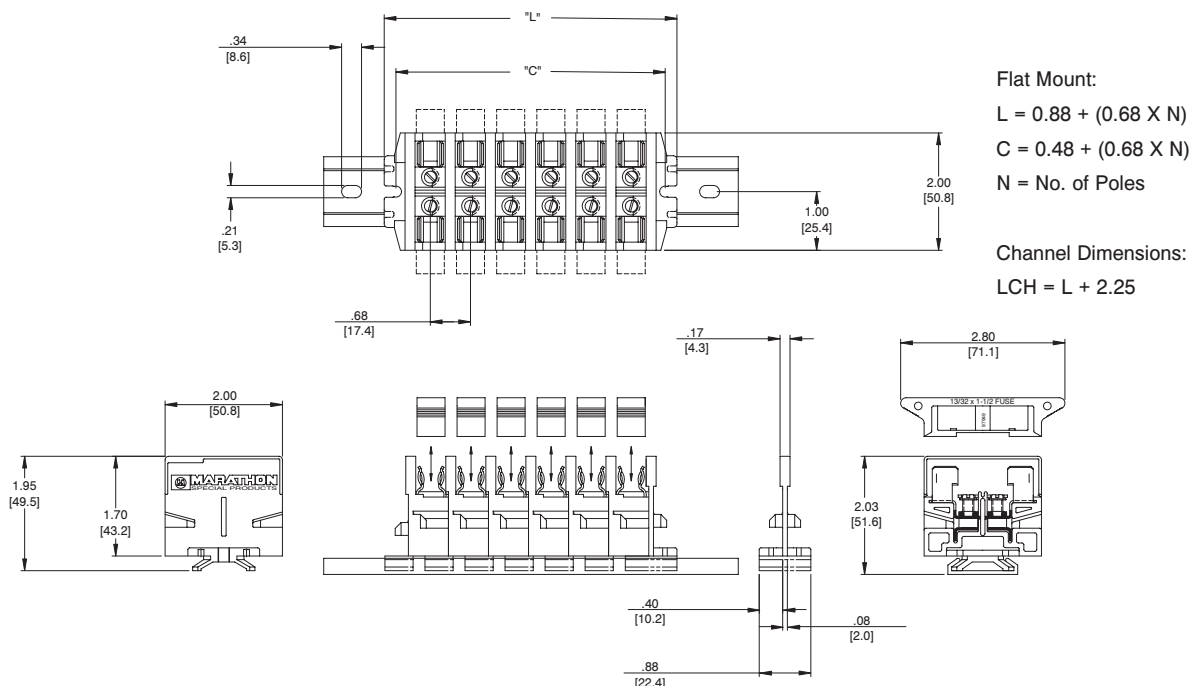

DIN Rail Terminal Blocks

General Information:

Marathon DIN Rail Terminal Blocks are ideal for various applications such as machine tool controls, distribution and instrumentation installations, switchgear, elevator and panelboard construction.

Insulating Materials:

The moldings are made of Nylon 6/6, Gray. This material has high creepage resistance and high impact strength. It also has a UL 94V-2 flammability rating and is resistant to gasoline, oil, alcohol and many other chemicals.

Temperature Rating: 100°C / 212°F Continuous
170°C / 338°F Intermittent & Short Exposure

Connector System:

The connectors are made of copper alloy and are nickel-plated for corrosion resistance. The screws are rolled steel, zinc plated. The total connector system provides the following benefits:

1. The system ensures that no matter how small the cross section of the wire it can only be inserted into the connection hole.
2. A serrated pressure plate eliminates any wire damage from the torquing of the screw.
3. The upward pressure on the screw from the pressure plate reduces the risk of a screw loosening due to vibration.
4. The pressure plate also compensates for some reduction in contact pressure caused by cold flow in the wire.
5. The design of the pressure plate and its heavy construction eliminates tilting, even with solid wires.
6. The use of rolled rather than turned screw threads provide for the application of higher torque without thread damage.

Reference Chart:

Catalog Number	Page	Amps	Volts	Wire Range	Thickness	Terminals per Foot	Wire Termination Torque
MIK3	120	20	600	#12-#22 AWG	5 mm	60	5
MIK5	121	30	600	#10-#22 AWG	6 mm	50	13.3
MIK10	122	50	600	#8-#22 AWG	8 mm	38	13.3
MIK16	123	65	600	#6-#22 AWG	10 mm	30	18
MIK25	124	85	600	#4-#8 AWG	12 mm	25	53
MIKTS4	125	20	300	#12-#22 AWG	6 mm	-	-
MIKSI5	126	10	300	#10-#20 AWG	8 mm	-	-
MIKE4	126	-	-	#10-#22 AWG	7 mm	-	8.0
MIKE10	126	-	-	#8 AWG	8 mm	-	13.3
MIKE16	126	-	-	#6 AWG	10 mm	-	18

See Page 137 for Identification Labels
MSK35 - End Bracket Securing Torque 7-9 lb-in (.8-1 N-m)

DIN Rail Terminal Blocks

MIK3

5 mm - 600 Volts AC/DC

Specifications:

- Insulating Material, Nylon- 6/6, Gray
- Wire Range #12-#22 AWG – 20 Amps
- UL Recognized File No. XCFR2.E62806
- CSA Certified File No. LR700930- 25 Amps
- VDE – 26 Amps
- **CE**
- RoHS Compliant

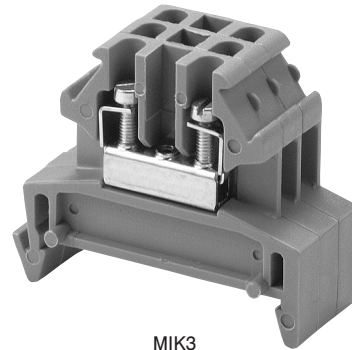

MIK3

Catalog #	Description
MIK3	Center Section
MN35-2	DIN Rail symmetrical 35 X 7.5 mm slotted 2 m long, steel zinc-plated
MVB2-2	Jumper 2-position
MVB2-12	Jumper 12-position
MVL2-2	Connecting straps for linking together two adjacent 12-pole jumpers
MIW2	Insulating end sections for covering and insulating the last terminal in an assembly
MIW4	Insulating partition walls for visual/electrical separation of terminal groups
MKAW2	Safety cover with warning label for line terminals which cannot be disconnected
MSK35	End bracket used on both ends of the assembly to hold blocks in place

Wire strip length 1/4"

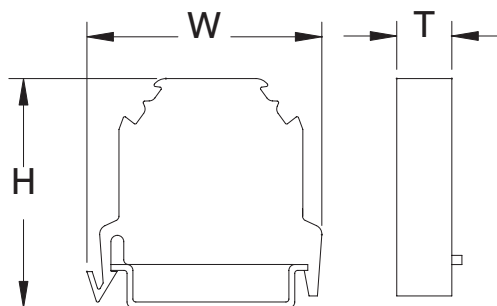

Dimensions:

H = 36 mm (1.417")
W = 42 mm (1.653")
T = 5 mm (.197")

For electronic drawings or 2D/3D CAD data,
send request to drawings@marathonsp.com

DIN Rail Terminal Blocks

MIK5

6 mm - 600 Volts AC/DC

Specifications:

- Insulating Material, Nylon 6/6, Gray
- Wire Range #10-#22 AWG – 30 Amps
- UL Recognized File No. XCFR2.E62806
- CSA Certified File No. LR700930- 25 Amps
- VDE – 24 Amps
- CE
- RoHS Compliant



Catalog #	Description
MIK5	Center Section
MN35-2	DIN Rail symmetrical 35 X 7.5 mm slotted 2 m long, steel zinc-plated
MVB4-2	Jumper 2-position
MVB4-12	Jumper 12-position
MVL4-2	Connecting straps for linking together two adjacent 12-pole jumpers
MSTB2	Plug Sockets - test plugs of 2.3 mm Ø
MPST2	Test Plugs - 2.3 mm Ø
MIW4	Insulating end sections for covering and insulating the last terminal
MIW16	Insulating partition walls for visual/electrical separation of terminal groups
MKAW2	Safety cover with warning label for line terminals which cannot be disconnected
MSK35	End bracket used on both ends of the assembly to hold blocks in place

Wire strip length .30"

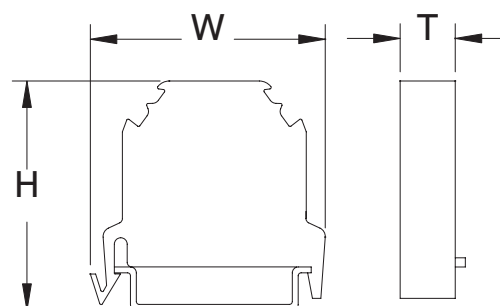

Dimensions:

H = 38 mm (1.496")

W = 42 mm (1.653")

T = 6 mm (.236")

For electronic drawings or 2D/3D CAD data,
send request to drawings@marathonsp.com

DIN Rail Terminal Blocks

MIK10

8 mm - 600 Volts AC/DC

Specifications:

- Insulating Material, Nylon 6/6, Gray
- Wire Range #8-#22 AWG – 50 Amps
- UL Recognized File No. XCFR2.E62806
- CSA Certified File No. LR700930- 50 Amps
- VDE – 61 Amps
- CE
- RoHS Compliant



MIK10

Catalog #	Description
MIK10	Center Section
MN35-2	DIN Rail symmetrical 35 X 7.5 mm slotted 2 m long / steel zinc-plated
MVB6-2	Jumper 2-position
MVB6-12	Jumper 12-position
MVL6-2	Connecting straps for linking together two adjacent 12 pole jumpers
MSTB2	Plug Sockets- test plugs of 2.3 mm Ø
MPST2	Test Plugs- 2.3 mm Ø
MIW16	Insulating end sections for covering and insulating the last terminal in an assembly
MIW50	Insulating partition walls for visual and electrical separation of terminal groups
MKAW10	Safety cover with warning label for line terminals which cannot be disconnected
MSK35	End bracket used on both ends of the assembly to hold blocks in place

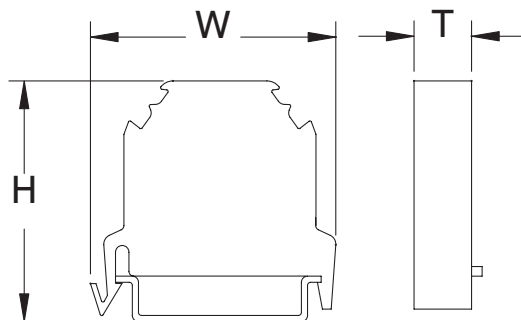

Dimensions:

H = 44 mm (1.732")
 W = 42 mm (1.653")
 T = 8 mm (.315")

For electronic drawings or 2D/3D CAD data,
 send request to drawings@marathonsp.com

DIN Rail Terminal Blocks

MIK16

10 mm - 600 Volts AC/DC

Specifications:

- Insulating Material, Nylon 6/6, Gray
- Wire Range #6-#22 AWG – 65 Amps
- UL Recognized File No. XCFR2.E62806
- CSA Certified File No. LR700930- 68 Amps
- VDE – 82 Amps
- CE
- RoHS Compliant

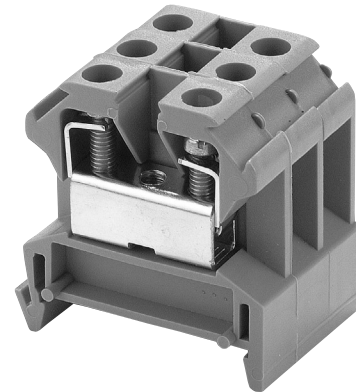

MIK16

Catalog #	Description
MIK16	Center Section
MN35-2	DIN Rail symmetrical 35 X 7.5 mm slotted 2 m long / steel zinc-plated
MVB16-2	Jumper 2-position
MVB16-12	Jumper 12-position
MVBL16	Removable connecting jumpers for the connection of adjacent lines
MVL16-2	Connecting straps for linking together two adjacent 12 pole jumpers
MIW16	Insulating end sections for covering and insulating the last terminal in an assembly
MIW50	Insulating partition walls for visual and electrical separation of terminal groups
MKAW16	Safety covers with warning label for line terminals which cannot be disconnected
MSK35	End bracket used on both ends of the assembly to hold blocks in place

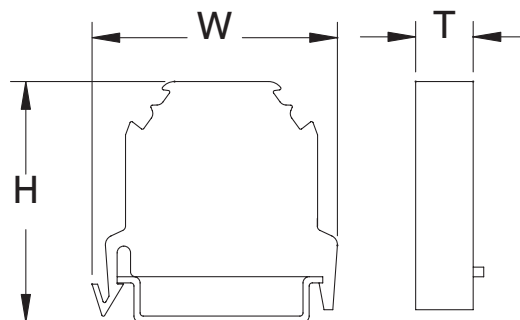

Dimensions:
 H = 44 mm (1.732")
 W = 42 mm (1.653")
 T = 10 mm (.394")

For electronic drawings or 2D/3D CAD data,
 send request to drawings@marathonsp.com

MIK25

12 mm - 600 Volts AC/DC

Specifications:

- Insulating Material, Nylon 6/6, Gray
- Wire Range #4-#8 AWG – 85 Amps
- UL Recognized File No. XCFR2.E62806
- CSA Certified File No. LR700930- 70 Amps
- VDE – 108 Amps
- **CE**
- RoHS Compliant

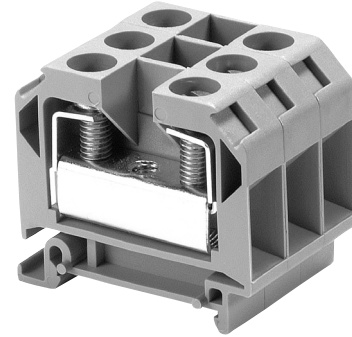

MIK25

Catalog #	Description
MIK25	Center Section
MN35-2	DIN Rail symmetrical 35 X 7.5 mm slotted 2 m long, steel zinc-plated
MVB25	Jumpers 2-position
MVL25	Connecting straps- 2 position
MVL25-3	Connecting straps- 3 position
MVBU35	Supports for use under the MVL straps using M 6 X 15 screws
MSTB35	Plug sockets for test plugs of 4 mm Ø
MPST4	Test plugs- 4 mm Ø
MIW50	Insulating end sections for covering and insulating the last terminal in an assembly
MIW70	Insulating partition walls for visual and electrical separation of terminal groups
MKAW25	Safety covers with warning label for supply line terminals which cannot be disconnected
MSK35	End bracket used on both ends of the assembly to hold blocks in place

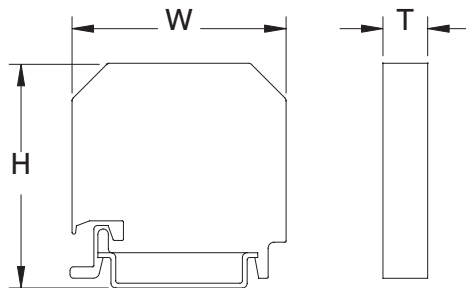

Dimensions:

H = 48 mm (1.89")
 W = 50 mm (1.97")
 T = 12 mm (.47")

For electronic drawings or 2D/3D CAD data,
 send request to drawings@marathonsp.com

DIN Rail Terminal Blocks

MIKTS4 (Disconnect)

6 mm - 300 Volts AC/DC

Specifications:

- Insulating Material, Nylon 6/6, Gray
- Wire Range #12-#22 AWG – 20 Amps
- CSA Certified File No. LR700930
- VDE – 16 Amps
- CE
- RoHS Compliant

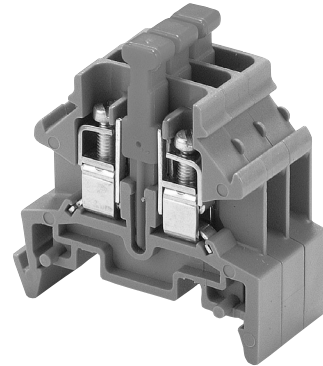

MIKTS4

Catalog #	Description
MIKTS4	Center Section
MN35-2	DIN Rail symmetrical 35 X 7.5 mm slotted 2 m long / steel zinc-plated
MDSBL (Plug only)	Diode plug - blue with diode 400 Volt, 1 Amp cathode on high voltage side
MDSRT (Plug only)	Diode plug - red with diode 400 Volt, 1 Amp cathode on low voltage side
MPST2	Test Plug- 2.3 mm Ø
MIW4	Insulating end sections for covering and insulating the last terminal in an assembly
MSK35	End bracket used on both ends of the assembly to hold blocks in place

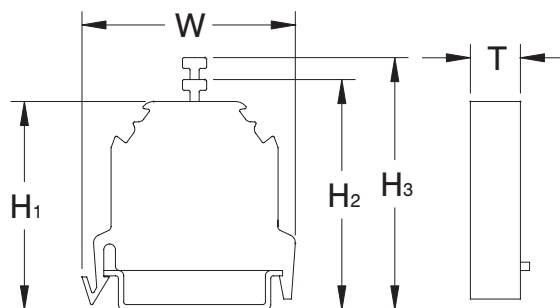

Dimensions:

H1	=	39 mm (1.535")
H2	=	46 mm (1.800")
H3	=	53 mm (2.100")
W	=	42 mm (1.653")
T	=	6 mm (.236")

For electronic drawings or 2D/3D CAD data,
send request to drawings@marathonsp.com

MIKSI5

8 mm - 300 Volts AC/DC

Specifications:

- Insulating Material, Nylon 6/6, Gray
- Wire Range #10-#20 AWG – 10 Amps
- VDE - 4 mm²
- IEC - 6.3 Amps
- UL Recognized File No. IZLT2.E35113 – 10 Amps
- Fuse Type - 5 x 20 mm, 5 x 25 mm
- **CE**
- RoHS Compliant

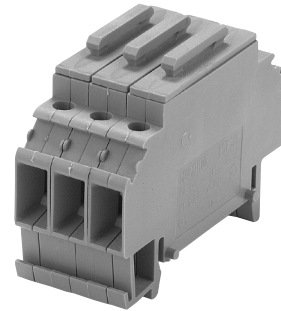

MIKSI5

Catalog #	Description
MIKSI5	Center Section
MN35-2	DIN Rail symmetrical 35 X 7.5 mm slotted 2 m long, steel zinc-plated
MIW50	Insulating partition walls for visual and electrical separation of terminal groups
MSK35	End bracket used on both ends of the assembly to hold blocks in place

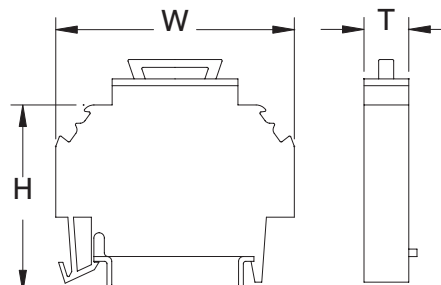

Dimensions:

H = 47 mm
(1.850")
W = 60 mm
(2.362")
T = 8 mm
(.315")

MIKE4, MIKE10, MIKE16

7 mm, 8 mm, 10 mm

Specifications:

- Insulating Material, Nylon 6/6, Green/Yellow
- Wire Range:
MIKE4 - #10-#22 AWG
MIKE10 - #8 AWG
MIKE16 - #6 AWG
- UL Recognized File No. XCFR2.E62806
- CSA Certified File No. LR700930
- VDE
- **CE**
- RoHS Compliant

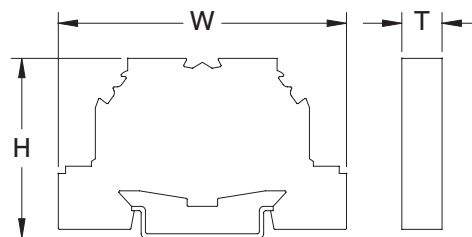

Dimensions:

H = MIKE4 38 mm (1.496")
MIKE10 44 mm (1.771")
MIKE16 44 mm (1.732")
W = 56 mm (2.204")
T = MIKE4 7 mm (.275")
MIKE10 8 mm (.315")
MIKE16 10 mm (.394")

For electronic drawings or 2D/3D CAD data,
send request to drawings@marathonsp.com

DIN Rail Terminal Blocks

Universal Identification Labels Type MSH

Specifications:

- Strips of Ten
- Large Surface Area
- Available Plain, with Numbers, Letters or Symbols
- Can be Labeled Vertically or Horizontally
- Single Label MSH 5 can be Used for all Sizes
- RoHS Compliant



Ordering Code:

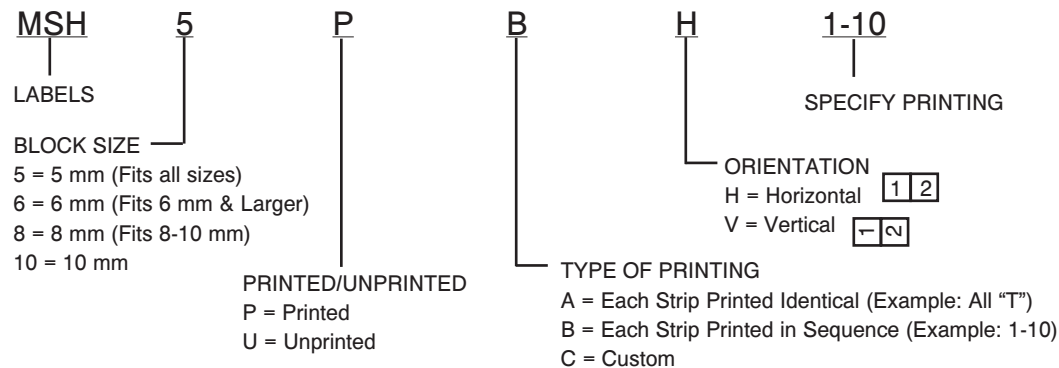

Universal Identification Labels Type MSK 2/10

Specifications:

- Identification with Up to 4 or 6 Digits
- Star Shaped Applicator for Easy Insertion of Labels into Holder
- MSKT 5/4 Holder Fits all Sizes - 4 Digits
- MSKT 5/6 holder Fits all Sizes - 6 Digits
- Each Wheel Comes with 10 Identical Numbers or Letters
- RoHS Compliant

MSK 2/10
Applicator

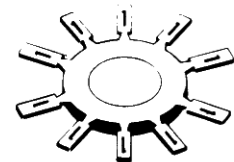

MSKT 5/4
Holder

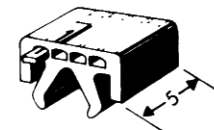

MSKT 5/6
Holder

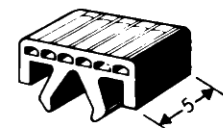

Ordering Code:

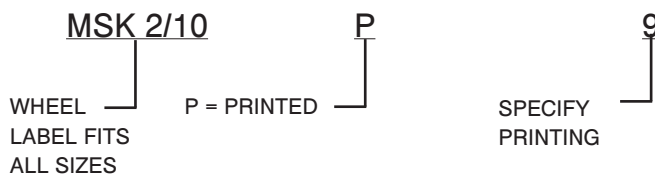

Kulka® Military Class (A-A-59125) / (MIL-T-55164*)

Military Class: Closed Back

Supercedes MIL-T-59125

These military blocks feature molded-in terminals in an improved Kulka® design for greater strength and flexibility. The mounting holes are covered with molded-in reinforcement straddle plates.

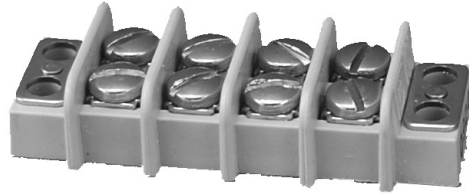

37TB04B

A-A-59125/ MIL-T-55164 Information		Terminal Type	Voltage		Current	Wire & Lug Information				
Class	Spec #		Description	Max Rated		Dielectric with Test	Max Rated	Screw Size	RECMD Max Wire Size	MS17143 Lug #
37 TB	/ 1	Double Screw	300 V RMS	3000 V RMS	15 Amp 60 Hz	#6	#16 AWG	-11	0.282" [7.2]	8-10 [0.9-1.1]
38 TB	/ 2	Double Screw	600 V RMS	3400 V RMS	20 Amp 60 Hz	#6	#14 AWG	-14	0.31" [7.9]	8-10 [0.9-1.1]
39 TB	/ 3	Double Screw	600 V RMS	4000 V RMS	30 Amp 60 Hz	#8	#10 AWG	-9	0.41" [10.4]	10-12 [1.1-1.4]
40 TB	/ 4	Single Screw Feed Thru	300 V RMS	3000 V RMS	7.5 Amp 60 Hz	#6	#18 AWG	-10	0.282" [7.2]	8-10 [0.9-1.1]
41 TB	/ 5	Single Screw Feed Thru	600 V RMS	3400 V RMS	10 Amp 60 Hz	#6	#16 AWG	-14	0.31" [7.9]	8-10 [0.9-1.1]
42 TB	/ 6	Single Screw Feed Thru	600 V RMS	4000 V RMS	15 Amp 60 Hz	#8	#14 AWG	-8	0.41" [10.4]	10-12 [1.1-1.4]

*Marathon Special Products manufactures terminal blocks that are constructed to meet MIL-T-55164C and A-A-59125. Mil standard A-A-59125, dated September 16, 1997, supercedes MIL-T-55164C. We will continue to supply the same parts for this spec. The CID identifier will be the same class number as for MIL-T-55164C.

The old MIL-T-55164C standard required Group A and Group B testing. The Group B testing was required every three years. Since the new A-A-59125 standard does not require Group B testing, we have elected to discontinue this test. We will continue to do Group A testing.

The following blocks are effected by this change:

Class/Spec #

- 37TB / 1
- 38TB / 2
- 39TB / 3
- 40TB / 4
- 41TB / 5
- 42TB / 6

Kulka® Military Class (A-A-59125) / (MIL-T-55164)

37TB-B/40TB-B Series

300 Volts AC/DC

Specifications:

- Base, Valox 420-SEO, Grey Color, 130°C
- Closed Back Design
- Screws, Brass Nickel Plate, 6-32 Binder Head, Slotted
- Terminals, Brass Nickel Plate, Ultrasonically Inserted
- 2-20 Poles, Consult Customer Service for Longer Lengths
- 3/8" Centers
- Flammability Rating 94 V-O
- Wire Size #16
- 15 Amps
- Parts are supplied with end plates
- RoHS Compliant

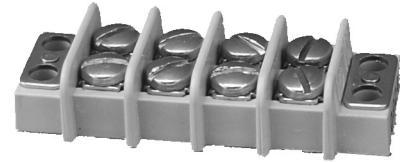

37TB04B

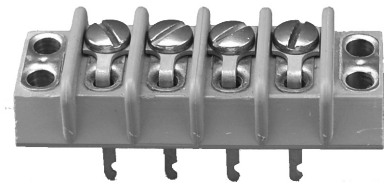

40TB04B

Catalog Number	Number of Poles	Dimensions	
		A	B
37TB02B	2	1.41	1.12
37TB03B	3	1.78	1.50
37TB04B	4	2.16	1.88
37TB05B	5	2.53	2.25
37TB06B	6	2.91	2.62
37TB07B	7	3.28	3.00
37TB08B	8	3.66	3.38
37TB09B	9	4.03	3.75
37TB10B	10	4.41	4.12
37TB11B	11	4.78	4.50
37TB12B	12	5.16	4.88
37TB13B	13	5.53	5.25
37TB14B	14	5.91	5.62
37TB15B	15	6.28	6.00
37TB16B	16	6.66	6.38
37TB17B	17	7.03	6.75
37TB18B	18	7.41	7.12
37TB19B	19	7.78	7.50
37TB20B	20	8.16	7.88

For electronic drawings or 2D/3D CAD data, send request to drawings@marathonsp.com

Hardware Options:

Lug Types (Commercial):

3/4 ST 600 = Half Solder

ST600 = Full Solder

See Page 102

See Page 102

Feed-Thru Hardware Options:

Long Feed-Thru Solder

40TB B Only

Accessories: (Jumper Commercial Grade)

Marking Strips = MSA, MSB, MSC

Jumper = J600, 600RJ, 600RJ(S)

See Page 134

See Page 103

Service Options:

Consult Customer Service

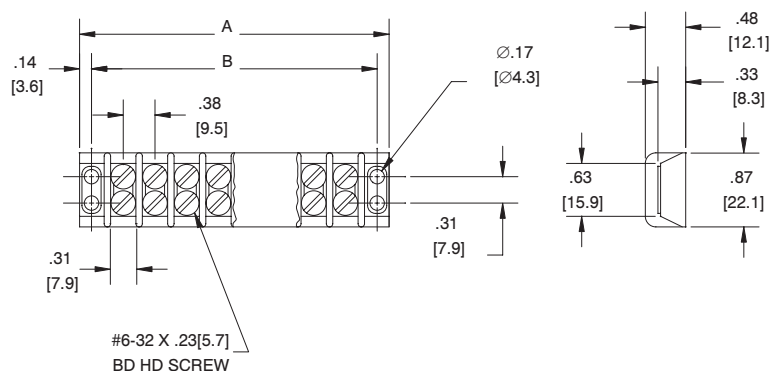

Kulka® Military Class (A-A-59125) / (MIL-T-55164)

37TB-Military Class (A-A-59125/1)/(MIL-T-55164/1)

Molded Material:

- Plastic: Grade F temperature rating 155°C per MIL-M-14
- Screws: Brass per QQ-W-321, nickel plated per QQ-N-290
- Terminal Plates: Brass per QQ-B-613, nickel plated per QQ-N-290

Electrical Rating:

- Rated voltage (maximum): 300 volts
- Current rating: 15 Amps
- D.W.V.: 3000 volts RMS

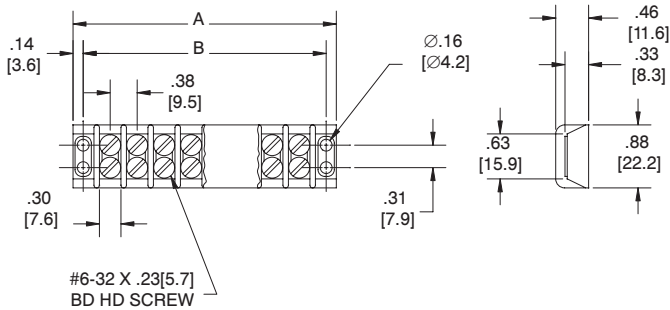

Military Type Designation	Number of poles	Dimensions	
		A	B
37TB 02 F	2	1.360-1.453	1.109-1.156
37TB 03 F	3	1.735-1.828	1.484-1.531
37TB 04 F	4	2.110-2.203	1.859-1.906
37TB 05 F	5	2.500-2.593	2.234-2.281
37TB 06 F	6	2.876-2.969	2.609-2.656
37TB 07 F	7	3.250-3.343	2.984-3.031
37TB 08 F	8	3.626-3.719	3.359-3.406
37TB 09 F	9	4.000-4.093	3.734-3.781
37TB 10 F	10	4.376-4.469	4.109-4.156
37TB 11 F	11	4.750-4.843	4.484-4.531
37TB 12 F	12	5.126-5.219	4.859-4.906
37TB 13 F	13	5.500-5.593	5.234-5.281
37TB 14 F	14	5.876-5.969	5.609-5.656
37TB 15 F	15	6.250-6.365	5.969-6.047
37TB 16 F	16	6.626-6.735	6.344-6.422
37TB 17 F	17	7.000-7.109	6.719-6.797
37TB 18 F	18	7.376-7.485	7.094-7.172
37TB 19 F	19	7.752-7.812	7.469-7.547
37TB 20 F	20	8.127-8.187	7.844-7.922
37TB 21 F	21	8.502-8.562	8.219-8.297
37TB 22 F	22	8.877-8.937	8.594-8.672
37TB 23 F	23	9.252-9.312	8.969-9.047
37TB 24 F	24	9.627-9.687	9.344-9.422
37TB 25 F	25	10.002-10.062	9.719-9.797
37TB 26 F	26	10.377-10.437	10.094-10.172
37TB 27 F	27	10.752-10.812	10.469-10.547
37TB 28 F	28	11.127-11.187	10.844-10.922
37TB 29 F	29	11.502-11.562	11.219-11.297
37TB 30 F	30	11.877-11.937	11.594-11.672
37TB 31 F	31	12.252-12.312	11.969-12.047

mm=dim X 25.4

38TB-Military Class (A-A-59125/2)/(MIL-T-55164/2)

Molded Material:

- Plastic: Grade F temperature rating 155°C per MIL-M-14
- Screws: Brass per QQ-W-321, nickel plated per QQ-N-290
- Terminal Plates: Brass per QQ-B-613, nickel plated per QQ-N-290

Electrical Rating:

- Rated voltage (maximum): 600 volts
- Current rating: 20 Amps
- D.W.V.: 3400 volts RMS

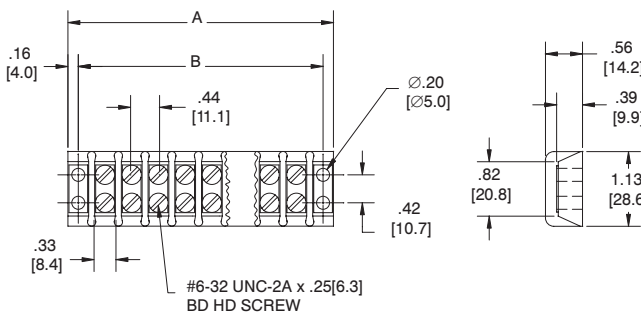

Military Type Designation	Number of poles	Dimensions	
		A	B
38TB 02 F	2	1.579-1.672	1.296-1.343
38TB 03 F	3	2.016-2.109	1.734-1.781
38TB 04 F	4	2.454-2.547	2.172-2.219
38TB 05 F	5	2.891-2.984	2.609-2.656
38TB 06 F	6	3.329-3.422	3.046-3.093
38TB 07 F	7	3.766-3.859	3.484-3.531
38TB 08 F	8	4.204-4.297	3.937-3.984
38TB 09 F	9	4.641-4.734	4.375-4.422
38TB 10 F	10	5.079-5.172	4.812-4.859
38TB 11 F	11	5.532-5.625	5.250-5.297
38TB 12 F	12	5.969-6.078	5.687-5.734
38TB 13 F	13	6.407-6.516	6.110-6.188
38TB 14 F	14	6.844-6.953	6.547-6.625
38TB 15 F	15	7.282-7.391	6.985-7.063
38TB 16 F	16	7.719-7.828	7.422-7.500
38TB 17 F	17	8.157-8.266	7.860-7.938
38TB 18 F	18	8.594-8.703	8.297-8.375
38TB 19 F	19	9.079-9.156	8.750-8.828
38TB 20 F	20	9.517-9.594	9.188-9.266
38TB 21 F	21	9.954-10.031	9.625-9.703
38TB 22 F	22	10.392-10.469	10.063-10.141
38TB 23 F	23	10.829-10.906	10.500-10.578

mm=dim X 25.4

For electronic drawings or 2D/3D CAD data, send request to drawings@marathonsp.com

Kulka® Military Class

(A-A-59125) / (MIL-T-55164)

39TB-Military Class (A-A-59125/3)/(MIL-T-55164/3)

Molded Material:

- Plastic: Grade F temperature rating 155°C per MIL-M-14
- Screws: Brass per QQ-W-321, nickel plated per QQ-N-290
- Terminal Plates: Brass per QQ-B-613, nickel plated per QQ-N-290

Electrical Rating:

- Rated voltage (maximum): 600 volts
- Current rating: 30 Amps
- D.W.V.: 4000 volts RMS

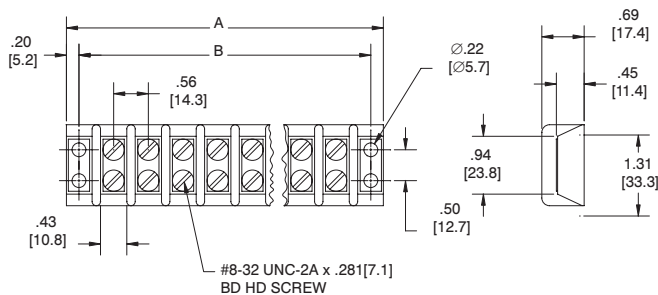

Military Type Designation	Number of poles	Dimensions	
		A	B
39TB 02 F	2	2.047-2.140	1.672-1.719
39TB 03 F	3	2.626-2.719	2.234-2.281
39TB 04 F	4	3.188-3.281	2.796-2.843
39TB 05 F	5	3.750-3.843	3.359-3.406
39TB 06 F	6	4.313-4.406	3.922-3.969
39TB 07 F	7	4.876-4.969	4.484-4.531
39TB 08 F	8	5.438-5.531	5.046-5.093
39TB 09 F	9	6.000-6.109	5.625-5.672
39TB 10 F	10	6.563-6.672	6.172-6.250
39TB 11 F	11	7.126-7.235	6.719-6.797
39TB 12 F	12	7.688-7.797	7.297-7.375
39TB 13 F	13	8.250-8.359	7.860-7.938
39TB 14 F	14	8.813-8.922	8.422-8.500
39TB 15 F	15	9.376-9.485	8.985-9.063
39TB 16 F	16	9.938-10.047	9.547-9.625
39TB 17 F	17	10.500-10.609	10.110-10.188
39TB 18 F	18	11.079-11.188	10.672-10.750

mm=dim X 25.4

40TB-Military Class (A-A-59125/4)/(MIL-T-55164/4)

Molded Material:

- Same as 37 TB Class
- Hardware: Lug, Brass per QQ-B-613, tin plated

Electrical Rating:

- Rated voltage (maximum): 300 volts
- Current rating: 7.5 Amps
- D.W.V.: 3000 volts RMS

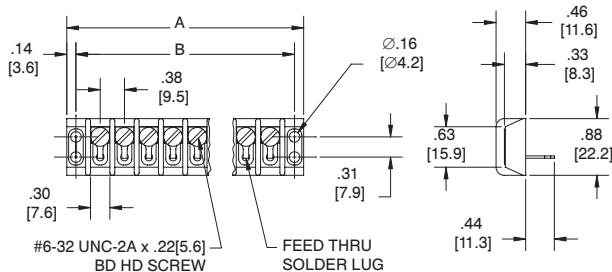

Military Type Designation	Number of poles	Dimensions	
		A	B
40TB 02 F	2	1.360-1.453	1.109-1.156
40TB 03 F	3	1.735-1.828	1.484-1.531
40TB 04 F	4	2.110-2.203	1.859-1.906
40TB 05 F	5	2.500-2.593	2.234-2.281
40TB 06 F	6	2.876-2.969	2.609-2.656
40TB 07 F	7	3.250-3.343	2.984-3.031
40TB 08 F	8	3.626-3.719	3.359-3.406
40TB 09 F	9	4.000-4.093	3.734-3.781
40TB 10 F	10	4.376-4.469	4.109-4.156
40TB 11 F	11	4.750-4.843	4.484-4.531
40TB 12 F	12	5.126-5.219	4.859-4.906
40TB 13 F	13	5.500-5.593	5.234-5.281
40TB 14 F	14	5.876-5.969	5.609-5.656
40TB 15 F	15	6.250-6.365	5.969-6.047
40TB 16 F	16	6.626-6.735	6.344-6.422
40TB 17 F	17	7.000-7.109	6.719-6.797
40TB 18 F	18	7.376-7.485	7.094-7.172
40TB 19 F	19	7.752-7.812	7.469-7.547
40TB 20 F	20	8.127-8.187	7.844-7.922
40TB 21 F	21	8.502-8.562	8.219-8.297
40TB 22 F	22	8.877-8.937	8.594-8.672
40TB 23 F	23	9.252-9.312	8.969-9.047
40TB 24 F	24	9.627-9.687	9.344-9.422
40TB 25 F	25	10.002-10.062	9.719-9.797
40TB 26 F	26	10.377-10.437	10.094-10.172
40TB 27 F	27	10.752-10.812	10.469-10.547
40TB 28 F	28	11.127-11.187	10.844-10.922
40TB 29 F	29	11.502-11.562	11.219-11.297
40TB 30 F	30	11.877-11.937	11.594-11.672
40TB 31 F	31	12.252-12.312	11.969-12.047

mm=dim X 25.4

For electronic drawings or 2D/3D CAD data,
send request to drawings@marathonsp.com

Datasheets available at marathonsp.com

Kulka® Military Class (A-A-59125) / (MIL-T-55164)

41TB-Military Class (A-A-59125/5)/(MIL-T-55164/5)

Molded Material:

- Same as 38 TB Class
- Hardware: Lug, Brass per QQ-B-613, tin plated

Electrical Rating:

- Rated voltage (maximum): 600 volts
- Current rating: 10 Amps
- D.W.V.: 3400 volts RMS

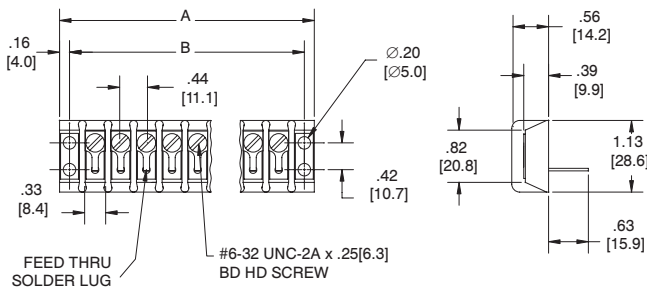

Military Type Designation	Number of poles	Dimensions	
		A	B
41TB 02 F	2	1.579-1.672	1.296-1.343
41TB 03 F	3	2.016-2.109	1.734-1.781
41TB 04 F	4	2.454-2.547	2.172-2.219
41TB 05 F	5	2.891-2.984	2.609-2.656
41TB 06 F	6	3.329-3.422	3.046-3.093
41TB 07 F	7	3.766-3.859	3.484-3.531
41TB 08 F	8	4.204-4.297	3.937-3.984
41TB 09 F	9	4.641-4.734	4.375-4.422
41TB 10 F	10	5.079-5.172	4.812-4.859
41TB 11 F	11	5.532-5.625	5.250-5.297
41TB 12 F	12	5.969-6.078	5.687-5.734
41TB 13 F	13	6.407-6.516	6.110-6.188
41TB 14 F	14	6.844-6.953	6.547-6.625
41TB 15 F	15	7.282-7.391	6.985-7.063
41TB 16 F	16	7.719-7.828	7.422-7.500
41TB 17 F	17	8.157-8.266	7.860-7.938
41TB 18 F	18	8.594-8.703	8.297-8.375
41TB 19 F	19	9.079-9.156	8.750-8.828
41TB 20 F	20	9.517-9.594	9.188-9.266
41TB 21 F	21	9.954-10.031	9.625-9.703
41TB 22 F	22	10.392-10.469	10.063-10.141
41TB 23 F	23	10.829-10.906	10.500-10.578

mm=dim X 25.4

42TB-Military Class (A-A-59125/6)/(MIL-T-55164/6)

Molded Material:

- Same as 39 TB Class
- Hardware: Lug, Brass per QQ-B-613, tin plated

Electrical Rating:

- Rated voltage (maximum): 600 volts
- Current rating: 15 Amps
- D.W.V.: 3400 volts RMS

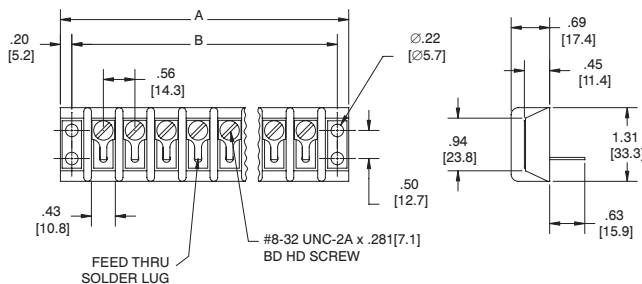

Military Type Designation	Number of poles	Dimensions	
		A	B
42TB 02 F	2	2.047-2.140	1.672-1.719
42TB 03 F	3	2.626-2.719	2.234-2.281
42TB 04 F	4	3.188-3.281	2.796-2.843
42TB 05 F	5	3.750-3.843	3.359-3.406
42TB 06 F	6	4.313-4.406	3.922-3.969
42TB 07 F	7	4.876-4.969	4.484-4.531
42TB 08 F	8	5.438-5.531	5.046-5.093
42TB 09 F	9	6.000-6.109	5.625-5.672
42TB 10 F	10	6.563-6.672	6.172-6.250
42TB 11 F	11	7.126-7.235	6.719-6.797
42TB 12 F	12	7.688-7.797	7.297-7.375
42TB 13 F	13	8.250-8.359	7.860-7.938
42TB 14 F	14	8.813-8.922	8.422-8.500
42TB 15 F	15	9.376-9.485	8.985-9.063
42TB 16 F	16	9.938-10.047	9.547-9.625
42TB 17 F	17	10.500-10.609	10.110-10.188
42TB 18 F	18	10.079-11.188	10.672-10.750

mm=dim X 25.4

For electronic drawings or 2D/3D CAD data,
send request to drawings@marathonsp.com

Kulka® Military Class

(A-A-59125) / (MIL-T-55164)

*Solder Hardware Dimensions are not to Mil Spec

37TBLD (Commercial Equivalent)

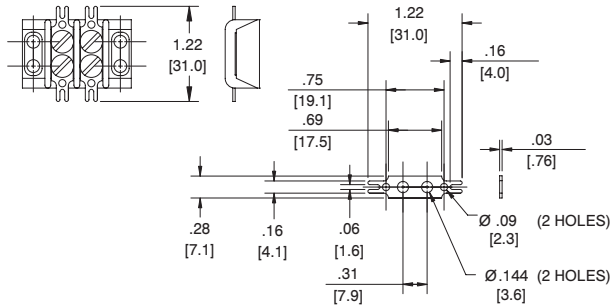

This is an assembly of the 37TB Class Terminal Board and a two-sided terminal lug (ST600). Available in lengths from 2 terminals through 31 terminals. Lugs are brass, tin plated.

37TBLS (Commercial Equivalent)

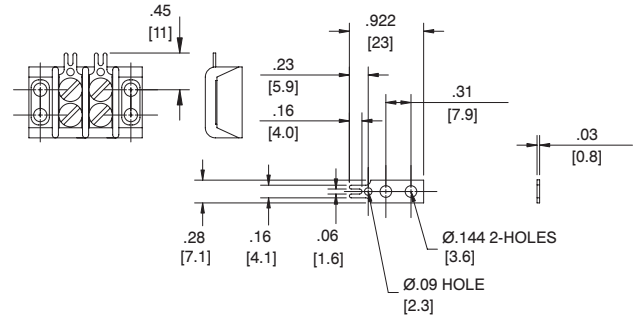

This is an assembly of the 37TB Class Terminal Board and a one-sided terminal lug (3/4 ST600). Available in lengths from 2 terminals through 31 terminals. Lugs are brass, tin plated.

38TBLD (Commercial Equivalent)

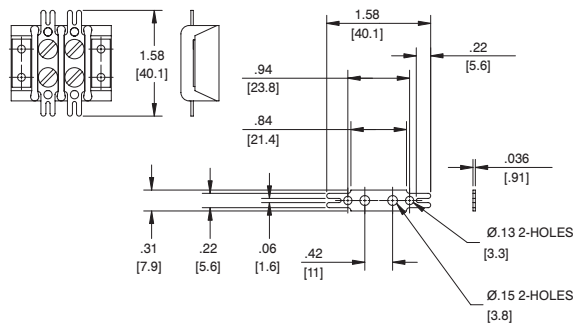

This is an assembly of the 38TB Class Terminal Board and a two-sided terminal lug (ST601). Available in lengths from 2 terminals through 23 terminals. Lugs are brass, tin plated.

38TBLS (Commercial Equivalent)

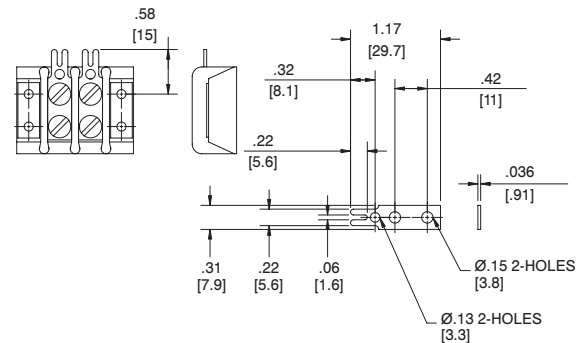

This is an assembly of the 38TB Class Terminal Board and a one-sided terminal lug (3/4 ST601). Available in lengths from 2 terminals through 23 terminals. Lugs are brass, tin plated.

39TBLD (Commercial Equivalent)

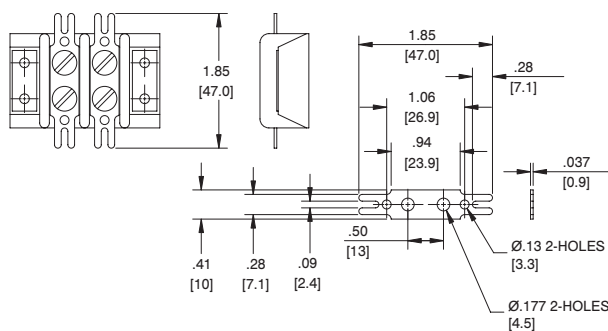

This is an assembly of the 39TB Class Terminal Board and a two-sided terminal lug (ST602). Available in lengths from 2 terminals through 18 terminals. Lugs are brass, tin plated.

39TBLS (Commercial Equivalent)

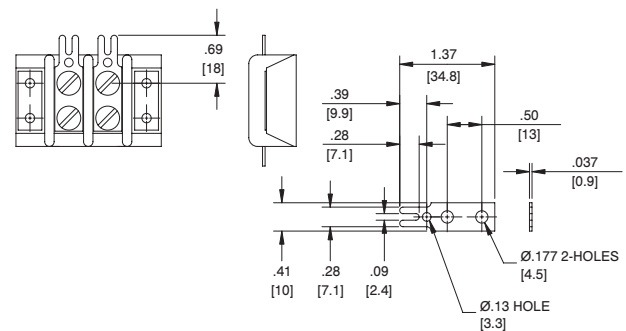

This is an assembly of the 39TB Class Terminal Board and a one-sided terminal lug (3/4 ST602). Available in lengths from 2 terminals through 18 terminals. Lugs are brass, tin plated.

To ensure solderability, use within six (6) months.

For electronic drawings or 2D/3D CAD data, send request to drawings@marathonsp.com

Datasheets available at marathonsp.com

Kulka[®] Military Class Marking Strips

Marking Styles MSA, MSB, MSC

Top Surface of Marking Strip

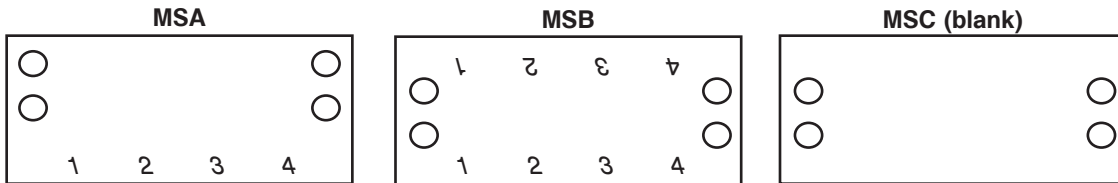

Bottom Surface of Marking Strip

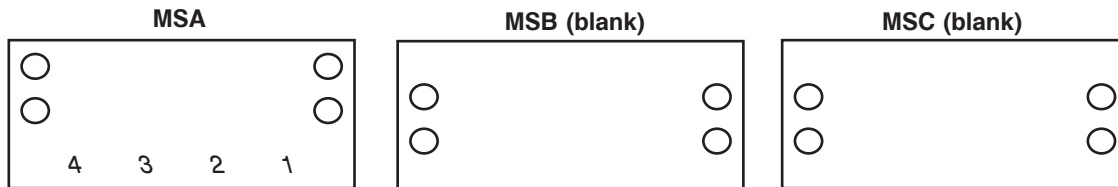

Requirements:

- Type Mount: Bottom Only
- Dimensions: See Page 110 for Charts
- Material: Type GME
- Marking: Marking Strips shall be Marked in Accordance with CID A-A-59125 (can be provided to MIL T55164)

A single letter shall be inserted in the above type designation to specify the marking style (A, B or C).

Both the front and the back of the marking strips shall be marked as indicated. The numbers shall be marked at a $45 \pm 2^\circ$ angle with reference to the side of the marking strip, as indicated.

Type MSC37TB (blank single sided marking strip) shall have the same dimensions as type MSA.

Kulka® Navy Class

(A-A-59125) / (MIL-T-55164*)

Notes:

Molded material is MAI-60 in accordance with MIL-M-14 (*Molded material is GDI30F).

The stud connector for these terminal boards is considered part of the stud and is required, unless otherwise specified. With the stud connector removed, the terminal board will provide twice the number of connection points and allow for an additional wire per terminal.

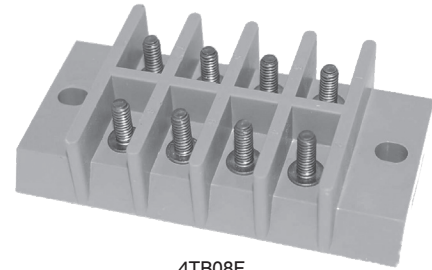

4TB08F

Nuts and connectors are provided when appropriate. They are unplated brass and shipped unassembled.

A-A-59125/ MIL-T-55164 Information		Terminal Type Description	Voltage		Current Max Rated	Wire & Lug Information				
Class	Spec #		Max Rated	Dielectric with Test		Screw Size	RECMD Max Wire Size	MS17143 Lug #	Max Lug Width	RECMD Torque Lb-In (N-M)
3 TB	/ 9	Single Stud Single Row	600 V RMS	2000 V RMS	45 Amp 60 Hz	#8	#10 AWG	-3	0.395" [10.0]	16-18 [1.8-2.0]
4 TB	/ 10	Single Stud Double Row	600 V RMS	2200 V RMS	40 Amp 60 Hz	#8	#12 AWG	-3	0.395" [10.0]	16-18 [1.8-2.0]
5 TB	/ 11	Feed Thru Stud Single Row	600 V RMS	2200 V RMS	50 Amp 60 Hz	#8	#10 AWG	-3	0.395" [10.0]	16-18 [1.8-2.0]
6 TB	/ 12	Single Stud Double Row	600 V RMS	2200 V RMS	30 Amp 60 Hz	#6	#14 AWG	-5	0.307" [7.8]	10-12 [1.1-1.4]
7 TB	/ 13	Feed Thru Stud Single Row	600 V RMS	2200 V RMS	40 Amp 60 Hz	#6	#12 AWG	-6	0.307" [7.8]	10-12 [1.1-1.4]
8 TB 8 TBHT*	/ 14	Double Stud Double Row	300 V RMS	1500 V RMS	30 Amp 60 Hz	#5	#14 AWG	-11	0.282" [7.2]	8-10 [0.9-1.1]
9 TB	/ 15	Single Stud Single Row	300 V RMS	1500 V RMS	35 Amp 60 Hz	#6	#12 AWG	—	0.307" [7.8]	10-12 [1.1-1.4]
10 TB	/ 16	Single Stud Double Row	600 V RMS	2200 V RMS	30 Amp 60 Hz	#6	#14 AWG	—	0.242" [6.11]	10-12 [1.1-1.4]
11 TB	/ 17	Feed Thru Stud Single Row	600 V RMS	2200 V RMS	40 Amp 60 Hz	#6	#12 AWG	-15	0.242" [6.1]	10-12 [1.1-1.4]
15 TB	/ 19	Single Stud Double Row	600 V RMS	2200 V RMS	30 Amp 60 Hz	#8	#14 AWG	-8	0.307" [7.8]	16-18 [1.8-2.0]
16 TB	/ 20	Single Stud Double Row	1000 V RMS	3000 V RMS	40 Amp 60 Hz	#8	#12 AWG	-3	0.395" [10.0]	16-18 [1.8-2.0]
17 TB	/ 21	Double Stud Double Row	600 V RMS	2200 V RMS	40 Amp 60 Hz	#6	#12 AWG	-3	0.395" [10.0]	10-12 [1.1-1.4]
18 TB	/ 22	Single Stud Single Row	600 V RMS	2200 V RMS	45 Amp 60 Hz	#8	#10 AWG	-3	0.395" [10.0]	16-18 [1.8-2.0]
25 TB 25 TBHT*	/ 23	Single Stud Single Row	300 V RMS	1500 V RMS	25 Amp 60 Hz	#4	#14 AWG	-17	0.242" [6.1]	6-8 [0.7-0.9]
26 TB 26 TBHT*	/ 24	Double Stud Double Row	300 V RMS	1500 V RMS	20 Amp 60 Hz	#4	#16 AWG	-20	0.242" [6.1]	6-8 [0.7-0.9]

*Marathon Special Products manufactures terminal blocks that are constructed to meet MIL-T-55164C and A-A-59125. Mil standard A-A-59125, dated September 16, 1997, supercedes MIL-T-55164C. We will continue to supply the same parts for this spec. The CID identifier will be the same class number as for MIL-T-55164C.

The old MIL-T-55164C standard required Group A and Group B testing. The Group B testing was required every three years. Since the new A-A-59125 standard does not require Group B testing, we have elected to discontinue this test. We will continue to do Group A testing.

The following blocks are effected by this change:

Class/Spec #				
3TB / 9	6TB / 12	9TB / 15	15TB / 19	18TB / 22
4TB / 10	7TB / 13	10TB / 16	16TB / 20	25TB / 23
5TB / 11	8TB / 14	11TB / 17	17TB / 21	26TB / 24

Kulka® Navy Class (A-A-59125) / (MIL-T-55164)

3TB SERIES (A-A-59125/9) / (MIL-T-55164/9)

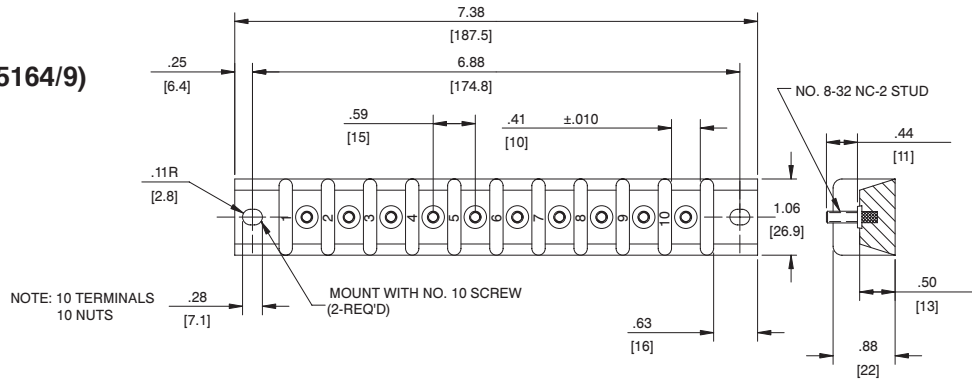

4TB SERIES (A-A-59125/10) / (MIL-T-55164/10)

Double Row, Front Connection				
	# of Term	Dim. A	Dim. B	Nuts
4 TB 08F	8	3.38	2.88	8
4 TB 20F	20	6.50	6.00	20

mm = dim X 25.4

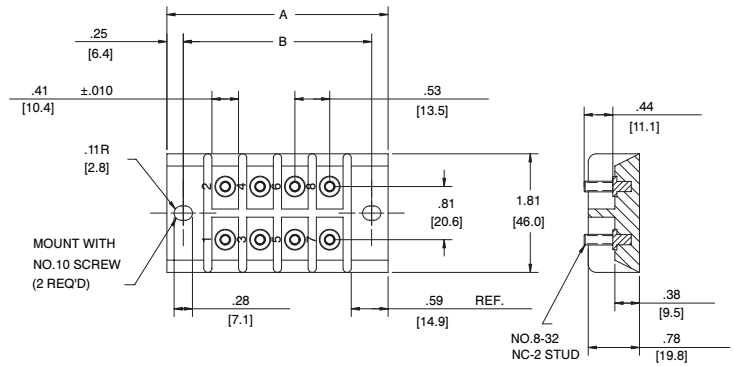

5TB SERIES (A-A-59125/11) / (MIL-T-55164/11)

Single Row, Through Connection				
	# of Term	Dim. A	Dim. B	Nuts
5 TB 08F	8	6.13	5.63	16
5 TB 10F	10	7.38	6.88	20

mm = dim X 25.4

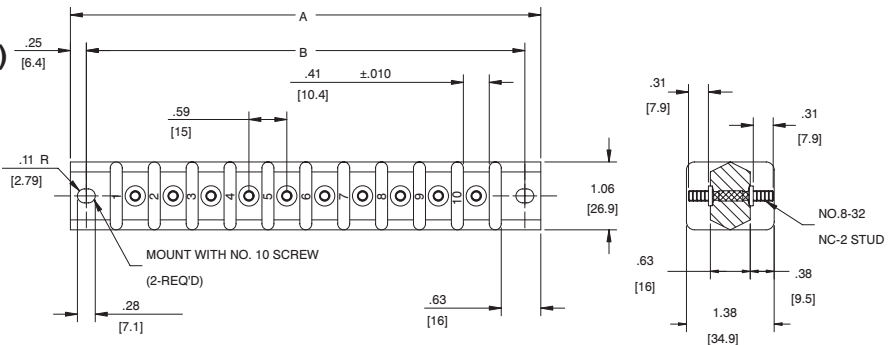

6TB SERIES (A-A-59125/12) / (MIL-T-55164/12)

Double Row, Front Connection				
	# of Term	Dim. A	Dim. B	Nuts
6 TB 06F	6	2.50	2.00	6
6 TB 10F	10	3.38	2.88	10
6 TB 24F	24	6.50	6.00	24

mm = dim X 25.4

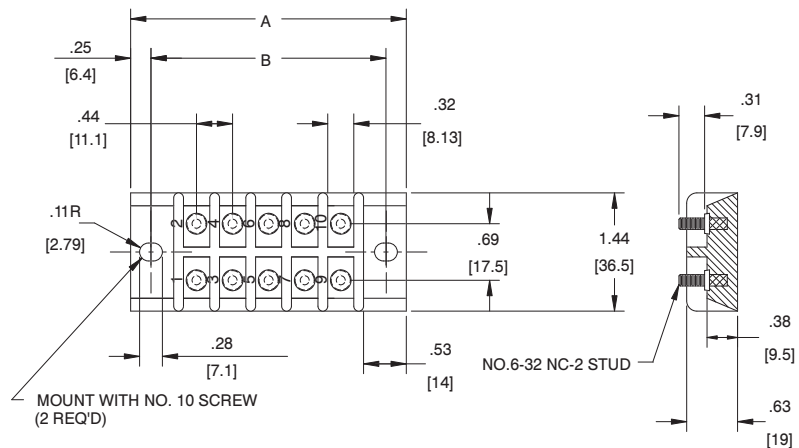

For electronic drawings or 2D/3D CAD data, send request to drawings@marathonsp.com

Kulka® Navy Class

(A-A-59125) / (MIL-T-55164)

7TB SERIES

(A-A-59125/13) / (MIL-T-55164/13)

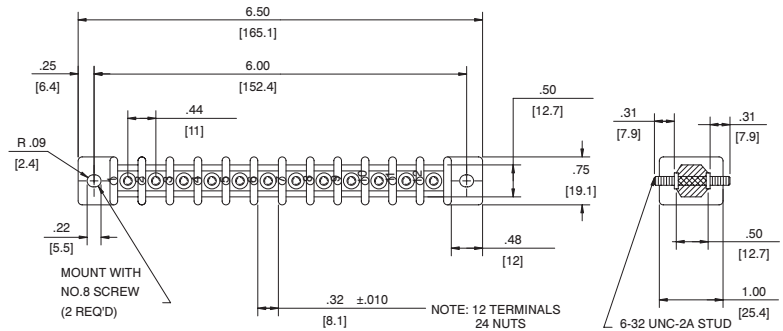

8TB SERIES

(A-A-59125/14) / (MIL-T-55164/14)

Double Row, Linked Front Connection

	# of Term.		Dim. A	Dim. B	Nuts
	w/stud connectors	w/o stud connectors			
8 TB 02F	2	4	1.63	1.25	4
8 TB 06F	6	12	3.13	2.75	12
8 TB 08F	8	16	3.88	3.50	16
8 TB 10F	10	20	4.63	4.25	20

8TBHT also available mm = dim X 25.4

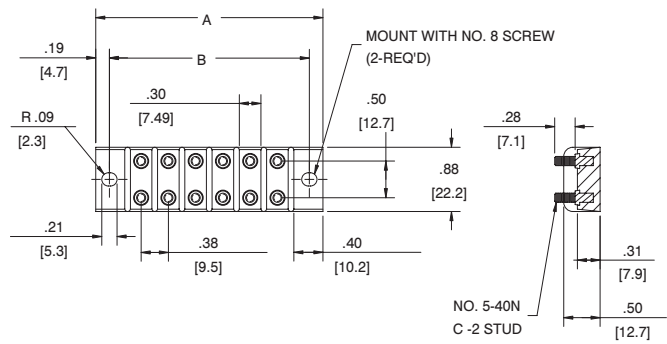

9TB SERIES

(A-A-59125/15) / (MIL-T-55164/15)

Single Row, Front Connection

Type	# of Term.	Dim. A	Nuts
9 TB 02F	2	1.48	2
9 TB 04F	4	2.37	4

mm = dim X 25.4

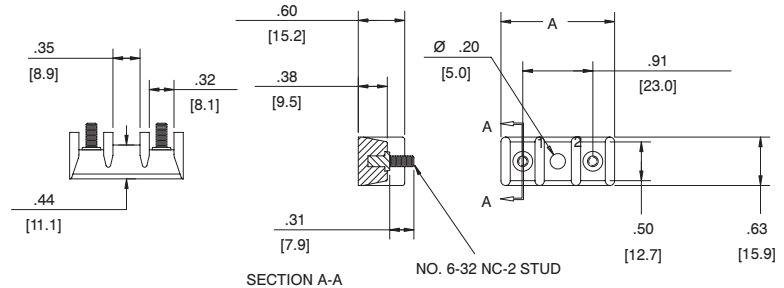

10TB SERIES

(A-A-59125/16) / (MIL-T-55164/16)

Double Row, Front Connection

Type	# of Term.	Dim. A	Dim. B	Dim. C	Nuts
10 TB 18F	18	4.63	4.13	0.56	18
10 TB 28F	28	6.50	6.00	0.56	28

mm = dim X 25.4

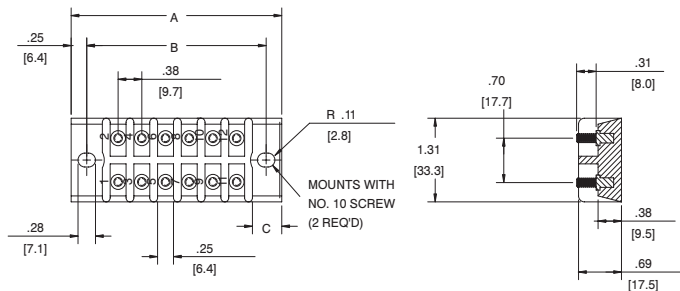

11TB SERIES

(A-A-59125/17) / (MIL-T-55164/17)

Single Row, Through Connection

Type	# of Term.	Dim. A	Dim. B	Dim. C	Nuts
11 TB 04F	4	2.50	2.00	0.44	8
11 TB 06F	6	3.38	2.88	0.44	12
11 TB 14F	14	6.50	6.00	0.56	28

mm = dim X 25.4

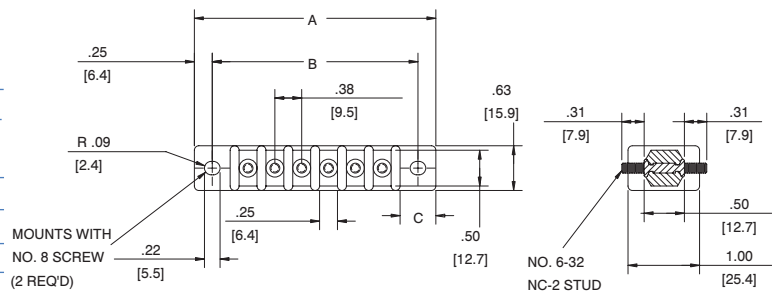

For electronic drawings or 2D/3D CAD data, send request to drawings@marathonsp.com

Datasheets available at marathonsp.com

Kulka® Navy Class (A-A-59125) / (MIL-T-55164)

15TB SERIES

(A-A-59125/19) / (MIL-T-55164/19)

Double Row, Front Connection

Type	Number of Terminals	Dim. A	Dim. B	Nuts
15 TB 10F	10	3.38	2.88	10
15 TB 24F	24	6.50	6.00	24

mm = dim X 25.4

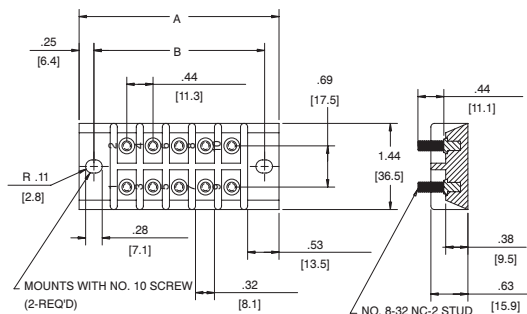

16TB SERIES

(A-A-59125/20) / (MIL-T-55164/20)

Double Row, Front Connection

Type	Number of Terminals	Dim. A	Dim. B	Nuts
16 TB 04F	4	3.38	2.88	4
16 TB 10F	10	6.50	6.00	10

mm = dim X 25.4

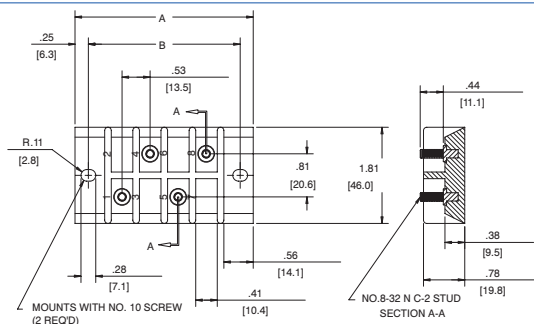

17TB SERIES

(A-A-59125/21) / (MIL-T-55164/21)

Double Row, Front Connection

Type	Number of Terminals		Dim. A	Dim. B	Nuts
	w/stud connectors	w/o stud connectors			
17 TB 10F	10	20	6.50	6.00	10

mm = dim X 25.4

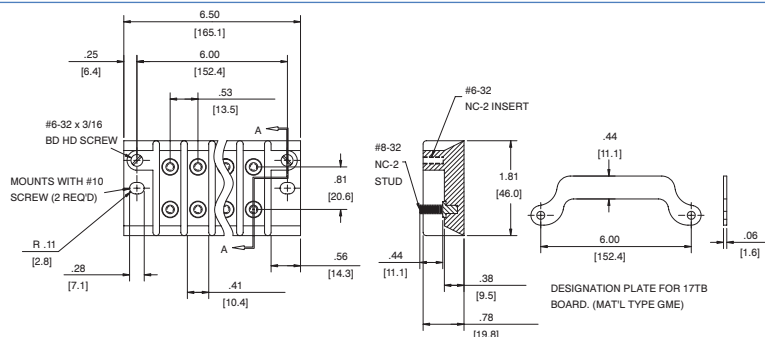

25TB SERIES

(A-A-59125/23) / (MIL-T-55164/23)

Single Row, Front Connection

Type	# of Term.	Dim. A	Dim. B	Nuts
25 TB 02F	2	1.38	1.06	2
25 TB 05F	5	2.31	2.00	5
25 TB 06F	6	2.63	2.31	6
25 TB 07F	7	2.94	2.63	7
25 TB 09F	9	3.56	3.25	9
25 TB 10F	10	3.88	3.56	10
25 TB 12F	12	4.50	4.19	12

25TBHT also available

mm = dim X 25.4

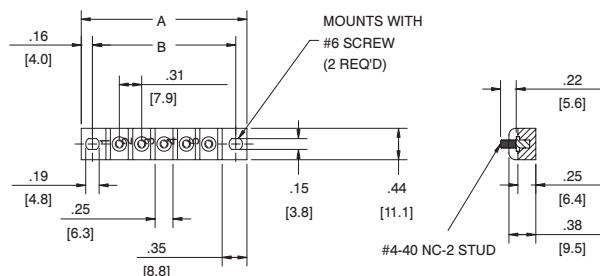

26TB SERIES

(A-A-59125/24) / (MIL-T-55164/24)

Double Row, Linked Front Connection

Type	# of Term.		Dim. A	Dim. B	Nuts
	w/stud connectors	w/o stud connectors			
26 TB 06F	6	12	2.63	2.31	12
26 TB 08F	8	16	3.25	2.94	16
26 TB 10F	10	20	3.88	3.56	20
26 TB 12F	12	24	4.50	4.19	24

26TBHT also available

mm = dim X 25.4

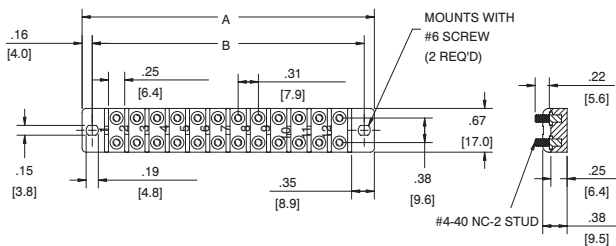

For electronic drawings or 2D/3D CAD data, send request to drawings@marathonsp.com

Datasheets available at marathonsp.com

Index

Catalog #	Page #	Catalog #	Page #	Catalog #	Page #
0987 RZ Series	67	141X205	49	145X606	48
100 Series	73	141X300	46	145X610	50
10TB-F Series	137	141X301	49	145X986	45
1100 Series	65	141X400	42	145X992	45
1103P	66	141X403	42	1500 Series	69
11TB-F Series	137	142X121	46	15TB-F Series	138
1200 Series	66	142X122	48	1600 Series	70
132X122 (CH)	48	142X123	48	1690 Series	95 - 96
132X422 (CH)	48	142X411	49	16TB-F Series	138
132X474 (CH)	50	142X552	46	1700 Series	71
132X570 (CH)	42	142X553	49	17TB-F Series	138
132X572 (CH)	46	142X570	42	1MS Series	28
132X574 (CH)	50	142X572	46	200 Series	74
132X580 (CH)	42	142X574	50	200HB Series	75
132X970 (CH)	42	142X970	42	2590 Series	97
132X972 (CH)	46	143X123	46	25TB-F Series	138
133X126 (CH)	47	143X124	46	2690 Series	98 - 99
133X270 (CH)	51	143X126	46	26TB-F Series	138
133X271 (CH)	51	143X306	47	300 Series	76
133X272 (CH)	51	143X552	43	3TB-F Series	136
133X273 (CH)	51	143X553	43	3/4 ST (Solder Term. Lugs)	102
133X280 (CH)	51	143X555	43	37TB-B Series	129
133X281 (CH)	51	143X559	50	37TB-F Series	130
133X305 (CH)	47	143X561	48	37TB-LD	133
133X320 (CH)	47	143X563	48	37TBLS	133
133X360 (CH)	47	143X587	44	38TB-F Series	130
133X552 (CH)	43	143X590	50	38TB-LD	133
133X554 (CH)	42	143X953	43	38TBLS	133
133X555 (CH)	43	143X955	43	39TB-F Series	131
133X558 (CH)	50	144X122	48	39TB-LD	133
133X559 (CH)	50	144X401	43	39TBLS	133
133X563 (CH)	48	144X551	44	400 Series	77
133X564 (CH)	48	144X553	48	40TB-B Series	129
133X565 (CH)	44	144X557	47	40TB-F Series	131
133X575 (CH)	44	144X560	43	410 GP Series	78
133X585 (CH)	44	144X569	50	411 Series	91
133X587 (CH)	44	144X575	50	411-1904	105
133X588 (CH)	44	144X614	48	41TB-F Series	132
133X595 (CH)	44	1453401	45	42TB-F Series	132
133X596 (CH)	45	145X129	47	4TB-F Series	136
133X597 (CH)	45	145X301	47	599 Series	92
133X598 (CH)	45	145X408	45	599-2002	105
133X953 (CH)	43	145X411	45	599-2004	105
133X955 (CH)	43	145X552	44	599-2020	105
140X303	46	145X573	48	599-2021	105
140X401	42	145X579	44	5TB-F Series	136
140X402	42	145X583	48	600-2004	105
140X404	42	145X586	45	600A-2002	105
140X801	46	145X587	45	600A GP Series	80
141X200	49	145X592	45	600 GP Series	79
141X201	49	145X594	44	601-2102	105
141X202	49	145X596	50	601-2104	105
141X203	50	145X599	50	601-2108	105

Catalog #	Page #	Catalog #	Page #	Catalog #	Page #
601 GP Series	81	6W30A Series	24, 118	R60A Series	12
602-2202	105	799 Series	92	R6CC60 Series	25
602 GP Series	82	7TB-F Series	137	R6F100A Series	11
603-2302	105	800A GP Series	80	R6F30A Series	11
603 GP Series	83	801 GP Series	81	R6F400A Series	11
604-2402	105	802 GP Series	82	R6F60A Series	11
604 GP Series	84	812 Series	94	R6J100A Series	19
605-2502	105	812-2202	105	R6J30A Series	19
605 GP Series	85	812-2204	105	R6J60A Series	19
621 RZ Series	86	899 Series	93	R6T30A Series	16
649 Series (Fanning Strips)	104	8TB-F Series	137	R6T60A Series	16
650 Series (Fanning Strips)	104	912 Series	94	RF100A Series	11
651 Series (Fanning Strips)	104	985 Series	68	RF30A Series	11
652 Series (Fanning Strips)	104	9TB-F Series	137	RF400A Series	11
699-2102	105	C7220X (Feed Thru covers)	57	RF60A Series	11
699-2104	105	Custom Products	144	RG15A Series	27
699-2120	105	DIN Rail Adapters	34	RG20A Series	27
699-2121	105	DIN Rail Labels (MSH, MSKT)	127	RG30A Series	27
699 Series	93	EPB Series (Listed)	38	RH Series (Fuse Panels)	9 - 10
670A GP Series	73	EPB Series	39 - 40	RJ, RJS Jumpers	103
670A RZ Series	87	F200A Series	11	RT30A Series	16
671 GP Series	74	F30A Series	11	RT60A Series	16
671 RZ Series	88	F600A Series	11	SCCR	35
672 GP Series	76	F60A Series	11	SPB (Straddle Plate)	103
672 RZ Series	89	Flex Wire	5 - 6	ST (Solder Terminal Lugs)	102
6CC30A Series	25	FPB23 Series	36 - 37	ST14	29
6F30A Series	11	FPB33 Series	36 - 37	ST38	29
6F200A Series	11	Fuse Holder Covers/Puller	32 - 33	ST710 Series	63
6F600A Series	11	Fuse Holder with BD	30	ST715S1902/Cover	61
6F60A Series	11	G15A Series	27	ST722B Series	58
6G38 Series	113, 115	G20A Series	27	ST722E Series	60
6H12 Series	117	G30A Series	27	ST722S Series	59
6H38 Series	114, 116	Grounding Lugs	56	ST723B38 Series	62
6J200A Series	19	J-JS Jumpers (LL)	103	STSF	31
6J30A Series	19	Kliptite (KT)/Quick Connect	100 - 101	T100A Series	16
6J400A Series	19	Marking Strips & Covers	106 - 111	T200A Series	16
6J600A Series	19	MIK10	122	T30A Series	16
6J60A Series	19	MIK16	123	T400A Series	16
6M30A Series	22	MIK25	124	T600A Series	16
6R100A Series	12	MIK3	120	T60A Series	16
6R200A Series	12	MIK5	121	Wire Clamp	103
6R30A Series	12	MIKE10	126	Y, YSY, Z	100
6R400A Series	12	MIKE16	126		
6R600A Series	12	MIKE4	126		
6R60A Series	12	MIKSI5	126		
6SC30A Series	26	MIKTS4	125		
6SM30A Series	23	Military Marking Strips	134		
6T100A	16	Power Block Covers	55		
6T200A	16	R100A Series	12		
6T30A	16	R200A Series	12		
6T400A	16	R30A Series	12		
6T600A	16	R400A Series	12		
6TB-F Series	136	R600A Series	12		

Terms and Conditions

ALL QUOTATIONS ARE MADE AND ALL ORDERS ARE ACCEPTED BY MARATHON SPECIAL PRODUCTS CORPORATION SUBJECT ONLY TO THESE TERMS AND CONDITIONS.

1. MODIFICATIONS OF SALES TERMS

Any Terms and Conditions contained in any purchase order or other form of communication from Marathon's customers which are additional or different from these Terms and Conditions shall be deemed rejected by Marathon unless expressly accepted in writing by Marathon. In general, no modification, amendment, waiver or other change of any of these Terms and Conditions and those contained on the reverse side hereof and/or in attachments hereto ("Terms and Conditions"), or of any of Marathon's rights or remedies thereunder, shall be binding on Marathon unless expressly accepted in writing by Marathon's authorized officers at Marathon's home office. No course of dealing, usage of trade or course of performance shall be relevant to explain or supplement any of these Terms and Conditions. In cases of conflict between the Terms and Conditions printed on this page and those contained on the face side or in attachment hereto, the latter shall control. If any document issued by any party hereto is sent by facsimile or another form of electronic document transmission, the parties hereto agree that (a) the copy of any such document printed on the facsimile machine or printer of the recipient thereof is a counterpart original copy thereof and is a "writing", (b) delivery of any such other form of electronic document to the recipient thereof by facsimile or such other form of electronic document transmission is authorized by the recipient thereof and is legally sufficient for all purposes as if delivered by United States mail, (c) the typewritten name of an authorized agent of the party sending such document on any such document is sufficient as a signature thereon and behalf of such party and the intent of such signature is to authenticate the writing, and (d) an electronically stored and reproduced copy of any such document shall be deemed to be legally sufficient evidence of the terms of such document for all purposes.

2. ACCEPTANCE OF ORDERS

Acceptance by Marathon of Buyer's purchase order(s) is expressly conditioned upon Buyer's assent to these Terms and Conditions. Buyer will be deemed to have assented to such Terms and Conditions unless Marathon receives written notice of any objection within fifteen (15) days after Buyer's receipt of this form and in all events prior to any delivery or other performance by Marathon of Buyer's order.

3. QUOTATIONS

Quotations by Marathon shall be deemed to be offers by Marathon to sell the equipment described therein subject to these Terms and Conditions, and acceptance of such offers is expressly limited to acceptance by Buyer of all of these Terms and Conditions within thirty (30) days from the date of the quotation. Purchase orders submitted by Buyer for the equipment quoted by Marathon shall be subject to and will be deemed to constitute acceptance of these Terms and Conditions. All purchase orders will be subject to approval by Marathon at Marathon's home office.

4. PRICES: PRICE CHANGES

All prices are net F.O.B. shipping point and are subject to change without notice. In the event of a change in Marathon's prices, the price for equipment unshipped will be the price in effect on the date of shipment.

If Marathon's quoted price was based on delivery to and acceptance by Buyer of a specified quantity of equipment, such price shall be subject to adjustment if Buyer does not accept the quantity at the times specified in Marathon's quotation, and Buyer will be invoiced at Marathon's standard price without quantity discounts, if any, for the quantity of equipment actually accepted by Buyer.

5. TAXES

In addition to any prices, Buyer shall pay the amount of any present or future manufacturer's tax, retailer's occupation tax, use tax, sales tax, excise tax, duty, custom, inspections or testing fee, or any other tax, fee or charge of any nature whatsoever imposed by any government authority, on or measured by the transaction between Marathon and Buyer. In the event Marathon is required to pay any such tax, fee or charge, Buyer shall reimburse Marathon therefor, or, in lieu of such payment, Buyer shall provide Marathon at the time the order is submitted with an exemption certificate or other document acceptable to the authority imposing such tax, fee or charge.

6. TERMS OF PAYMENT

All orders are subject to the approval of Marathon at its home office. Terms of payment are cash in full no later than thirty (30) days from date of shipment, without discount. If, during the period of performance of an order, the financial condition of Buyer is determined by Marathon not to justify the terms of payment specified, Marathon may demand full or partial payment in advance before proceeding with the work, or satisfactory security or guarantees that invoices will be promptly paid when due, or, at its option without prejudice to other lawful remedies, may defer delivery or cancel this contract. If delivery is deferred, the equipment may be stored as provided in Section 9 hereof and Marathon may submit a new estimate of cost for completion based upon prevailing conditions. If Buyer defaults in any payment when due, or in the event any voluntary or involuntary bankruptcy or insolvency proceedings involving Buyer are initiated by or against Buyer, then the whole contract price shall immediately become due and payable upon demand, or Marathon, at its option without prejudice to its other lawful remedies, may defer delivery or cancel this contract.

Prorata payments shall become due as shipments are made. If shipments are delayed by Marathon for any cause, payments shall become due from the date on which Marathon is prepared to make shipment and storage shall be at the Buyer's risk and expense as provided in Section 9 hereof. If manufacture is delayed by the Buyer for any cause, a Partial payment based upon the proportion of the order completed shall become due from the date on which Marathon is notified of the delay.

7. DELIVERY; RISK OF LOSS

All sales are F.O.B. Marathon's plant or other point of shipment designated by Marathon. Shipping dates are estimates only which are not guaranteed and are based upon prompt receipt from Buyer of all necessary shipping and other information, Marathon reserves the right to make delivery in installments. All installments to be separately invoiced and paid for by Buyer when due per invoice, without regard to subsequent deliveries.

Delivery of equipment to a commercial carrier at Marathon's plant or other loading point shall constitute delivery to Buyer, and any risk of loss and further cost and responsibility thereafter for claims, delivery, loss or damage, including if applicable, placement and storage shall be borne by Buyer. When equipment is delivered by Marathon's truck, unloading at Buyer's dock shall constitute delivery to Buyer. Claims for shortages or other errors in delivery must be made in writing to Marathon within ten (10) days after receipt of shipment and failure to give such notice shall constitute unqualified acceptance and a waiver of all such claims by Buyer. Claims for loss or damage to equipment in transit by common carrier must be made to the carrier and not to Marathon. Freight and handling charges by Marathon may not reflect actual freight charges prepaid to the carrier by Marathon due to incentive discounts earned by Marathon based upon Marathon's aggregate volume of freight tendered to a carrier or when a carrier must be used which charges a rate which is different than the rate upon which Marathon's freight and handling charges were based. When shipments are delivered in Marathon's private trucks, Buyer will be charged an amount approximating the prevailing common carrier rate.

8. EXCUSABLE DELAYS FORCE MAJEURE

Marathon shall not be liable for any loss or damage as a result of Marathon's delay in or failure of delivery or installation due to (i) any cause beyond Marathon's reasonable control, (ii) an act of God, act of the Buyer, embargo or other governmental act, authority regulation or request, fire, theft, accident, strike, slow-down or other labor disturbance, war, riot, delay in transportation, or (iii) inability to obtain necessary labor, materials, components or facilities.

Should any of the aforementioned events of force majeure occur, Marathon at its option, may cancel Buyer's order with respect to any undelivered equipment or extend the delivery date for a period equal to the time lost because of delay. Notice of such election shall be given promptly to Buyer. In the event Marathon elects to so cancel the order Marathon shall be released of and from all liability for failure to deliver the equipment including, but not limited to any and all claims on behalf of Buyer for lost profits or any other claim of any nature which Buyer might have.

If shipping or progress of the work is delayed or interrupted by Buyer, directly or indirectly, Buyer shall pay Marathon for all additional charges resulting therefrom.

9. STORAGE

If the equipment is not shipped within thirty (30) days after notification has been made to Buyer that it is ready for shipping, for any reason beyond Marathon's control, including Buyer's failure to give shipping instructions, Marathon may store the equipment at Buyer's risk and expense in a warehouse or upon Marathon's premises, and Buyer shall pay all handling, transportation and storage costs at the prevailing commercial rates promptly following Marathon's submission of invoices for such costs.

10. WARRANTIES TO DISTRIBUTORS AND INDUSTRIAL OR COMMERCIAL CUSTOMERS

This warranty is extended only to Marathon's distributors and industrial or commercial customers and does not apply to consumer purchasers.

Warranty Period - Marathon warrants products manufactured by it to be free from defects in materials and workmanship and to conform to Marathon's written specifications for a period of twelve (12) months from date of first use or eighteen (18) months from date of manufacture whichever period shall expire first.

Warranty Remedies - If prior to expiration of the foregoing warranty period, any product shall be proved to Marathon's satisfaction to be defective or nonconforming, Marathon will repair or replace such defective equipment or components thereof. F.O.B. Marathon's plant or other destination designated by Marathon or will refund or credit by Marathon, the purchase price paid therefor by Buyer, at Marathon's sole option. Buyer's exclusive remedy and Marathon's sole obligation under this warranty shall be limited to such repair or replacement, F.O.B. Marathon's plant or other destination designated by Marathon or refund or credit by Marathon, and shall be conditioned upon Marathon's receiving written notice of any defect within sixty (60) days after it was discovered or by reasonable care should have been discovered. In no event shall Marathon's liability for such defective or nonconforming products exceed the purchase price paid by Buyer therefore.

Exclusions - This warranty does not (i) cover shipping expenses to and from Marathon's factory or other destination designated by Marathon for repair or replacement of defective equipment or any tax, duty, custom, inspection or testing fee, or any other charge of any nature related thereto, nor does it cover the costs of removing defective equipment or reinstalling repaired or replaced equipment, (ii) apply and shall be void with respect to equipment operated in excess of rated capacity or otherwise not in accordance with installation, maintenance or operating instructions or requirements, to equipment repaired or altered by

Terms and Conditions

others than Marathon or Marathon's authorized service agencies, or to equipment which was subjected to abuse, negligence, misuse, misapplication, accident, damages by circumstances beyond Marathon's control, to improper installation (if by others than Marathon), operation, maintenance or storage, or to other than normal use or service, and (iii) apply to equipment or components not manufactured by Marathon. With respect to equipment or components not manufactured by Marathon, Marathon's warranty obligations shall in all respects conform and be limited to the warranty actually extended to Marathon by its suppliers but in no event shall Marathon's obligations be greater than those provided under Marathon's warranty set forth in this Section 10.

THE FOREGOING WARRANTIES ARE IN LIEU OF ALL OTHER EXPRESS AND IMPLIED WARRANTIES (EXCEPT TITLE), INCLUDING, WITHOUT LIMITATION, THE IMPLIED WARRANTIES OF MERCHANTABILITY AND FITNESS FOR A PARTICULAR PURPOSE. NO EMPLOYEE, REPRESENTATIVE, OR AGENT OF MARATHON OTHER THAN AN OFFICER OF MARATHON IS AUTHORIZED TO ALTER OR MODIFY ANY PROVISION OF THIS SECTION 10 OR TO MAKE ANY GUARANTEE, WARRANTY, OR REPRESENTATION, EXPRESS OR IMPLIED, ORALLY OR IN WRITING, WHICH IS CONTRARY TO THE FOREGOING. Any description of the equipment, whether in writing or made orally by Marathon or Marathon's agent, specifications, samples, models, bulletins, drawings, diagrams, engineering sheets or similar materials used in connection with Buyer's order are for the sole purpose of identifying the equipment and shall not be construed as an express warranty. Any suggestions by Marathon or Marathon's agents regarding use, application or suitability of the equipment shall not be construed as an express warranty unless confirmed to be such in writing by Marathon's authorized officer at Marathon's home office.

11. LIMITATIONS OF LIABILITY; CONSEQUENTIAL DAMAGES

Nuclear Use Disclaimer - Equipment sold by Marathon is not intended for use in connection with any nuclear facility or activity. If so used Marathon disclaims all liability for any nuclear damage, injury or contamination, and Buyer shall indemnify and hold Marathon, its officers, agents, employees, successors, assigns, and customers harmless from and against any and all losses, damages or expenses of whatever form or nature (including attorneys' fees and other costs of defending any action) which they or any of them may sustain or incur whether as a result of breach of contract, warranty, tort (including negligence) or otherwise, by reason of such use.

Consequential Damage Disclaimer - Marathon's liability with respect to equipment proved to its satisfaction to be defective within the warranty period shall be limited to repair, replacement or refund as provided in Section 10 hereof and in no event shall Marathon's liability exceed the purchase price of the equipment involved. Marathon shall not be subject to any other obligations or liabilities, whether arising out of breach of contract, warranty, tort (including negligence) or other theories of law, with respect to equipment sold or services rendered by Marathon, or any undertakings, acts or omissions relating thereto. Without limiting the generality of the foregoing, Marathon specifically disclaims any liability for property or personal injury damages, penalties, special or punitive damages, damages for lost profits or revenues, loss of use of equipment or any associated equipment, cost of capital, cost of substitute products, facilities or services, down-time, shut-down, or slow-down costs, or for any other types of economic loss, and for claims of Buyer's customers for any such damages.

MARATHON SHALL NOT BE LIABLE FOR AND DISCLAIMS ALL CONSEQUENTIAL, INCIDENTAL AND CONTINGENT DAMAGES WHATSOEVER. EVEN IF THE REPAIR OR REPLACEMENT REMEDY SHALL BE DEEMED TO HAVE FAILED OF ITS

ESSENTIAL PURPOSE UNDER SECTION 2-719 OF THE UNIFORM COMMERCIAL CODE, MARATHON SHALL HAVE NO LIABILITY TO BUYER FOR CONSEQUENTIAL DAMAGES, SUCH AS LOST PROFITS, LOST REVENUE, DAMAGE TO OTHER EQUIPMENT OR LIABILITY OR INJURY TO A THIRD PARTY.

12. INDEMNIFICATION BY BUYER

Buyer shall indemnify, hold harmless, and defend Marathon and Marathon's employees and agents from and against any and all damages, liability, claims, losses, and expenses (including reasonable attorneys' fees, court costs, and out-of-pocket expenses) arising out of or resulting in any way from claims by customers of Buyer or third parties against Marathon alleging a breach of contract or warranty by Marathon to the extent that such damages, liability, claims, losses, and expenses which may be payable by Marathon to Buyer pursuant to and as limited by Marathon's warranty and damage obligations as contained in Sections 10 and 11 hereof so as to effectively limit Marathon's obligations to customers of Buyer or third parties to those set forth in Sections 10 and 11 hereof.

13. PATENT INDEMNIFICATION

Marathon will at its own expense, defend or settle any suits that may be instituted against Buyer for alleged infringement by the equipment of any United States patent, provided that (a) such alleged infringements consists of the use of the equipment for any of the purposes for which such equipment was sold, (b) Buyer shall have made all payments for such equipment then due hereunder, (c) Buyer shall give Marathon immediate notice in writing of any such suit and transmit to Marathon immediately upon receipt all processes and papers served upon Buyer, and (d) Buyer shall permit Marathon through its counsel, either in the name of Buyer or in the name of Marathon, to defend such suit(s) and give all needed information, assistance and authority to enable Marathon to do so.

In case of a final award of damages in any such suit, Marathon will pay such award but will not be responsible for any compromise or settlement made without its written consent. In case the equipment itself is in such suit held to infringe any valid patent issued in the United States and its use enjoined, or in the event of a settlement or compromise approved by Marathon which shall preclude future use of the equipment sold to Buyer hereunder, Marathon shall, at its own expense and, at its sole option, either (a) procure rights to continue using such equipment, (b) modify the equipment to render it noninfringing, (c) replace the equipment with noninfringing equipment, or (d) refund the purchase price paid by Buyer for the equipment after return of the equipment to Marathon. Notwithstanding the foregoing, Marathon shall not be held responsible for infringements of combination or process patents covering the use of equipment in combination with other goods or materials not furnished by Marathon.

The foregoing states the entire liability of Marathon for patent infringement and **IN NO EVENT SHALL MARATHON BE LIABLE FOR CONSEQUENTIAL OR INCIDENTAL DAMAGES ATTRIBUTABLE TO AN INFRINGEMENT** nor for infringement based on the use of the equipment for a purpose other than that for which sold by Marathon. As to any equipment furnished by Marathon to Buyer manufactured in accordance with designs proposed or furnished by Buyer or any claim of contributory infringement resulting from the use or resale by Buyer of equipment sold hereunder, Buyer shall indemnify Marathon against any award made against Marathon for any patent, trademark or copyright infringements, including attorneys' fees and defense costs.

14. SECURITY AGREEMENT AND FINANCING STATEMENTS

To secure payment of the purchase price and of all monies which may be due hereunder, and performance of all of Buyer's obligations hereunder, Buyer hereby grants to Marathon a security interest in all equipment sold by Marathon, and agrees to execute such other Security Agreements and Financing Statements as

Marathon may reasonably request.

15. INSURANCE

Until payment in full of the purchase price, Buyer shall maintain insurance covering all equipment sold by Marathon to Buyer in such amounts and against such risks as is customary by companies engaged in the same or similar business and similarly located, and shall, upon Marathon's request, furnish evidence of such insurance satisfactory to Marathon.

16. DRAWINGS: OTHER DESIGN DATA

All specifications, drawings, design, data, information, ideas, methods, patterns and/or inventions made, conceived, developed or acquired by Marathon in connection with procuring and/or executing Buyer's order will vest in and inure to Marathon's sole benefit notwithstanding any changes thereof which may have been or may be imposed by Marathon.

Buyer shall not give, loan, exhibit, sell or transfer to any person not then employed by Buyer and authorized to receive such information, or to any organization or entity, any drawing, photograph, or specification furnished by Marathon or reproduction thereof which may enable such person, organization or entity to furnish similar goods or parts thereof.

17. RETURN OF EQUIPMENT

No equipment or part shall be returned to Marathon without written authorization and shipping instructions first having been obtained from Marathon.

18. ASSIGNMENT

None of the Buyer's rights under any order shall be assigned by the Buyer to any other person, whether by operation of law or otherwise, without Marathon's prior written approval. Marathon may, without the necessity of obtaining Buyer's prior written consent, subcontract the production of all or any portion of the equipment.

19. CANCELLATION

No order submitted to Marathon may be cancelled by Buyer without the prior written consent of Marathon, which consent will at all times be conditioned on Buyer's agreement to pay Marathon's cancellation charge. For finished equipment which in Marathon's judgment is readily resalable to others, the cancellation charge shall be 15% of the invoice price of the equipment. For all other cancellations the cancellation charge shall amount to all costs and expenses incurred by Marathon and arising out of or in connection with the Buyer's order, net of recoverability, but in no event less than 10% of the invoice price of the equipment or more than the invoice price.

20. GENERAL

Governing Law - These Terms and Conditions, and the contract of sale between Marathon and Buyer, shall be governed by and construed in accordance with the internal laws of the State of Ohio. Marathon and Buyer hereby agree that any legal action deemed necessary by either party hereto shall be brought in the Circuit Court in and for Wood County, Ohio and hereby consent to the personal jurisdiction of such court in any such action over the parties hereto. The rights and obligations of Marathon and Buyer shall not be governed by the provisions of the United Nations Convention on Contracts for the International Sales of Goods.

Attorneys' Fees - Buyer agrees to pay all of Seller's costs and expenses of collection and related litigation, including but not limited to attorneys' fees and costs.

Salvatory Clause - The invalidity, in whole or in part, of any of the provisions of these Terms and Conditions, shall not affect the enforceability of any of the other provisions thereof.

Applicability - The Terms and Conditions as stated herein are applicable as of the date of this printing and until such time as changed by Marathon.

Revised, January 2003

IMPORTANT INFORMATION PLEASE READ CAREFULLY

The following **DANGER**, **WARNING** and **CAUTION** information is supplied to you for your protection and to provide you with many years of trouble free and safe operation of your Marathon Special Products components.

DANGER

- Devices sold by Marathon Special Products provide for interconnection of electrical circuits and as such are, or can be, points of live electrical contact. It is the responsibility of the Buyer or user to ensure through the use of enclosures, insulation, engineering controls, or other means in the application, that the wiring device is protected from intentional or accidental contact in an energized condition. Failure to do so can create the potential for electrical shock and associated serious injury.
- Only qualified personnel should install and troubleshoot electrical products due to the potential for serious injury related to electrical shock. Make certain that the power supply is disconnected and/or locked out before attempting to install, remove or service components.

WARNING

- Connection tightness is critical to electrical performance. Buyer, user, or installer must always ensure that the proper screw torque is applied and maintained.
- Buyer or user must ensure that proper clearances are maintained between energized electrical components and all other devices including but not limited to the enclosure and mounting mechanism.

CAUTION

- Install and ground per local and national code.
- Buyer shall be solely responsible for determining the adequacy of the product for any and all uses to which Buyer shall apply the product. Buyer must ensure that the application of the device conforms to all standards, codes, policies or practices that govern or apply to their equipment or application. Marathon Special Products uses design parameters, materials, and construction methods intended to meet the standards noted in the engineering catalog, with specific suitability of use and restrictions as noted in the appropriate agency files. The application by Buyer shall not be subject to any implied warranty of fitness for a particular purpose.
- Products in this catalog are tested and listed with various standards agencies. They will meet or exceed all performance guidelines as tested and qualified. Buyer or user must check that applications do not exceed rated capacities of voltage and amperage and that appropriate wiring practices are followed.
- Products are intended for use in an "as sold" condition. Modification of components can affect performance and ratings and subsequently the safety of the component system. Buyer or user assumes liability for component modification.
- Electrical products in this catalog are designed for use in appropriate enclosures. Buyer or user is responsible to ensure that appropriate environmental control is designed into the application.

In the event of the resale of any goods, in whatever form, Resellers/Buyers will include the following language in a conspicuous place and in a conspicuous manner in a written agreement covering such sale:

The manufacturer makes no warranties or representations, express or implied, by operation of law or otherwise, as to the merchantability or fitness for a particular purpose of the goods sold hereunder. Buyer acknowledges that it alone has determined the goods purchased hereunder will suitably meet the requirements of their intended use. In no event will the manufacturer be liable for consequential, incidental or other damages. Even if the repair or replacement remedy shall be deemed to have failed of its essential purpose under section 2-719 of the Uniform Commercial Code, the manufacturer shall have no liability to Buyer for consequential damages.

Resellers/Buyers agree to also include this entire document including the dangers, warnings and cautions listed above in a conspicuous place and in a conspicuous manner in writing to instruct users on the safe usage of the product.

This information should be read together with all other printed information supplied by Marathon Special Products.

For more information contact: Marathon Special Products, Subsidiary of Marathon Electric, 13300 Van Camp Road, Bowling Green, OH. 43402 Phone: 419-352-8441 Fax: 419-352-0875

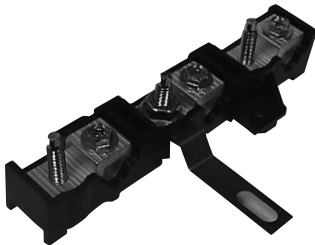
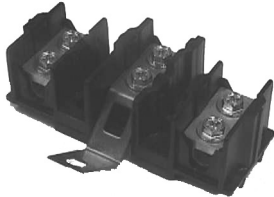

If it involves wire connections, we can engineer the solution and manufacture it for you. Whether it's a modification to a current product or a custom design, let Marathon Special Products provide the solution to your application needs. Our 75+ years of experience in designing, engineering and manufacturing electrical wire connection devices gives us the design expertise and manufacturing capabilities involving metal stampings, fabrication, thermoplastic and thermoset injection molding and components assembly.

Through the use of the latest 3D solid modeling and finite element analysis, we will convert concepts into design for production; thus, providing a cost competitive solution to meet your requirements in a timely manner. In our UL approved test lab, products are evaluated to ensure compliance with safety agency standards including UL, CSA and CE. In addition, Marathon's products are RoHS compliant. ISO 9001 certificated processes and controls assure delivery of quality products with continuous improvements.

Marathon Special Products will be pleased to propose a solution to meet your engineering, Agency, manufacturing and assembly requirements.

Give us a call today at (419) 352-8441, send an email to marketing@marathonsp.com, or visit www.marathonsp.com to learn more about how Marathon Special Products can provide that special application solution for your company.

The Right Product For Your Needs

Power Blocks

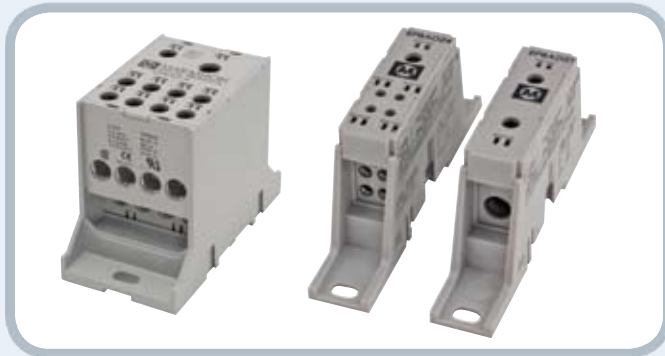

Fuse Holders



Terminal Blocks

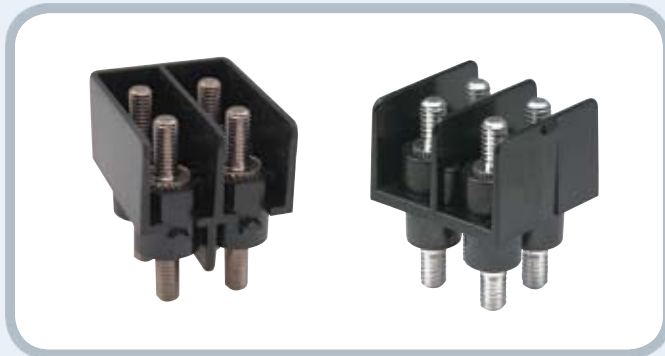

13300 Van Camp Road • P.O. Box 468 • Bowling Green, OH 43402
Phone: (419) 352-8441 • Fax: (800) 515-7151 or (419) 352-0875

www.marathonsp.com

ISO 9001
A2314



MARATHON
SPECIAL PRODUCTS

6380K-NP/5K/07-09/DBH

