

Studded Power Feed Thru Terminal Blocks

ST715S1902

Specifications:

Electrical:

- 300 Volts AC/DC (UL 1059 Class B and C)
- 80 Amps
- Wire Range #6 - #14
- Accommodates Two Hole Compression Lugs on .625" Centers

General/Mechanical:

- Base, Thermoplastic, 125°C (UL RTI)
- Studs, Brass, Nickel Plated
- 2 Poles
- .56" Centers
- Application Torque: 35 lbf-in
- UL Recognized File No. XCFR2.E62806
- cURus Certified File No. XCFR8.E62806
- CE
- RoHS Compliant

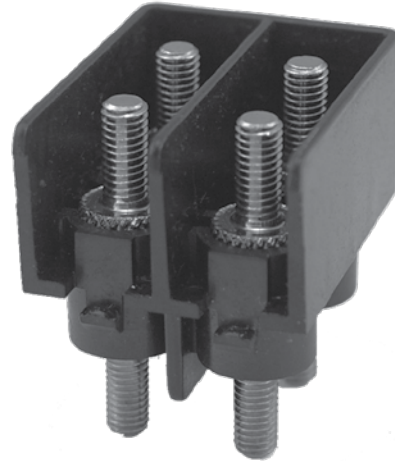

ST715S902

Hardware Options:

- (blank) – No hardware
- UH – All nuts shipped bulk
- AH – All nuts assembled
- DL – Assembled barrier side, remainder shipped bulk

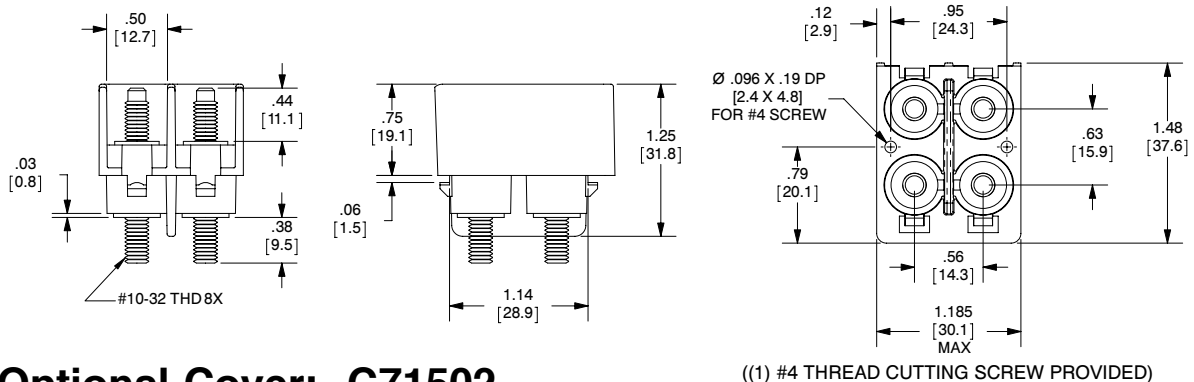

Optional Cover: C71502

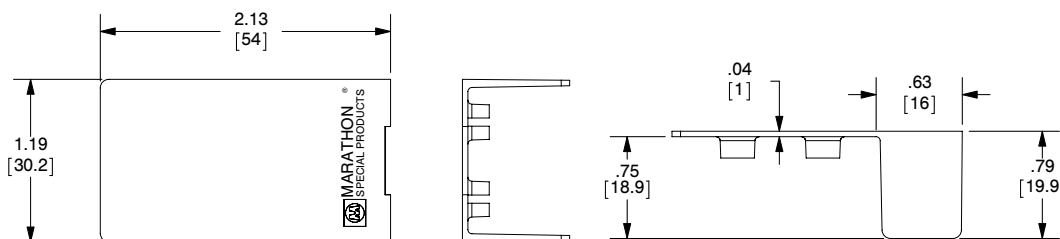

For electronic drawings or 2D/3D CAD data, submit request at www.marathonsp.com/drawings.html