

P.C.B. LAYOUT

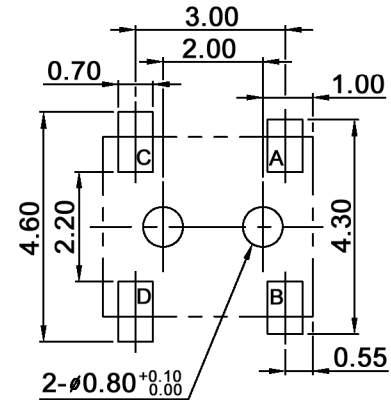

CIRCUIT DIAGRAM

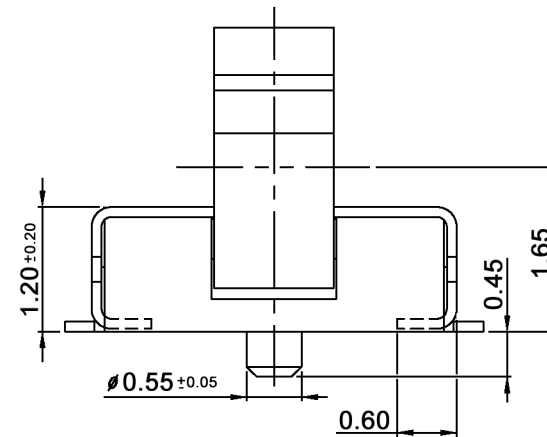
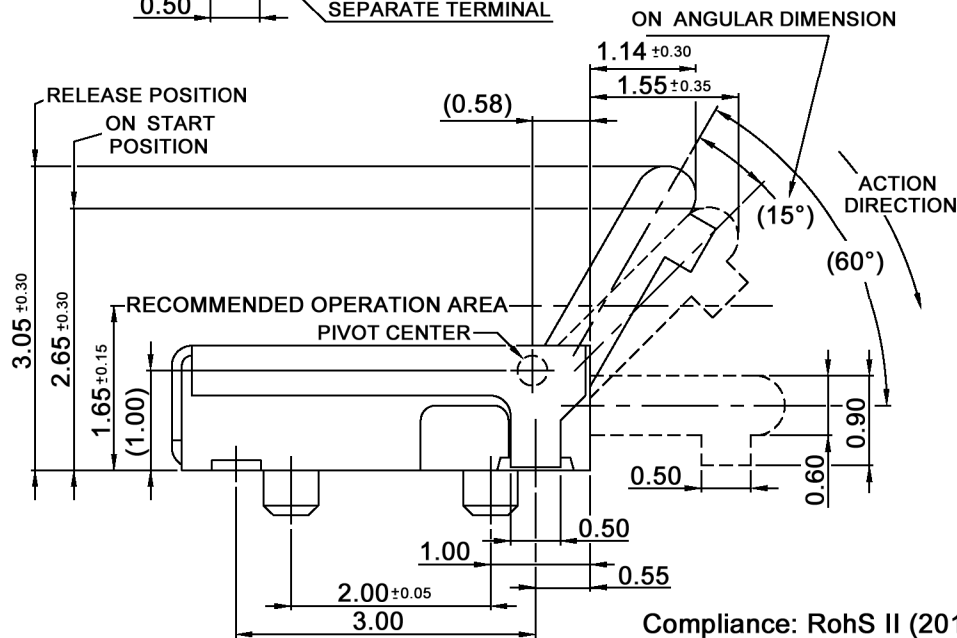
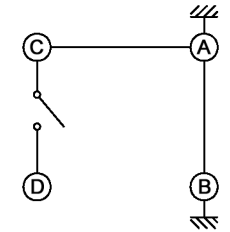

Compliance: RohS II (2011/65/EU)

Tolerances: max. ±0.20mm			Date	Name
			07/06	dr
Packaging	02/16	dr		
Specifications	05/15	dr		
Stop strength	04/15	dr		
Rename	05/14	dr		
Contact rating	07/08	dr		
Modifications	Date	Name		

**DTS 205 CP-T**

**knitter-switch**

**30 09 29**

Page

1/3

**Specifications:**

**Contact rating:** 100mA, 3.6V DC to 10mA, 5V DC  
**Contact resistance:** 1Ohm max.  
**Insulation resistance:** 100MOhm min. at 100V DC for 1 minute  
**Dielectric strength:** 100V AC (50Hz or 60Hz) for 1 minute  
**Operating temperature:** -40°C to +85°C  
**Storage temperature:** -40°C to +85°C  
**Operating force:** 40gf max.  
**Mechanical life:** 100 000 cycles min.  
**Stop strength:** 1kg for 60sec.  
**Material:** Cover: nickel silver  
 Stem / base: high-temp. thermoplastic PA9T, black  
 Contact: alloy copper, gold plated  
 Terminal: brass, silver plated

**Soldering conditions:**

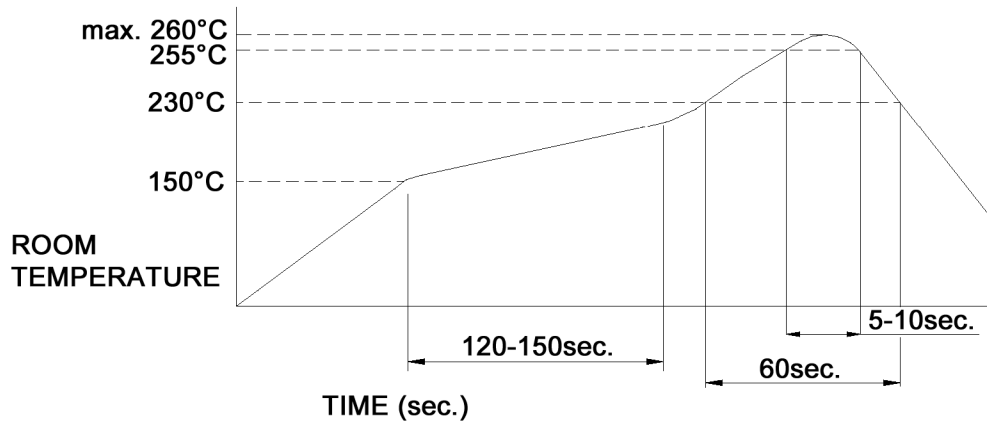

Manual soldering: max. 350°C; max. 5sec.

Compliance: RohS II (2011/65/EU)

Tolerances: max. ±0.20mm			Date	Name	<b>DTS 205 CP-T</b>
			07/06	dr	
			<b>knitter-switch</b>		<b>30 09 29</b>
					Page
					2/3
Modifications	Date	Name			

