

DASH NO.	M CODE	MADE FROM
----------	--------	-----------

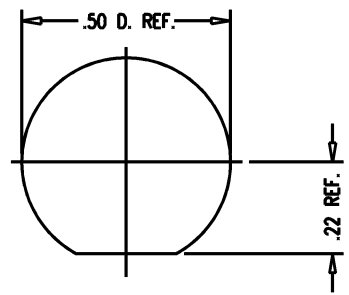
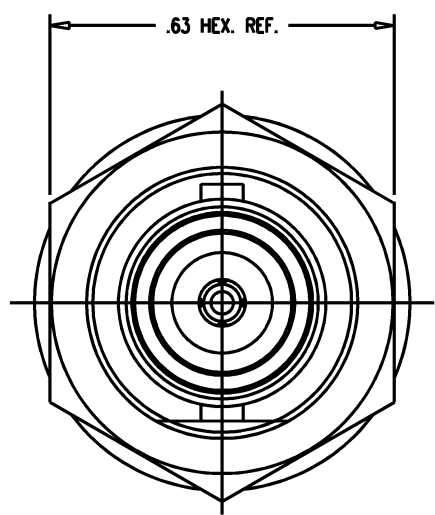
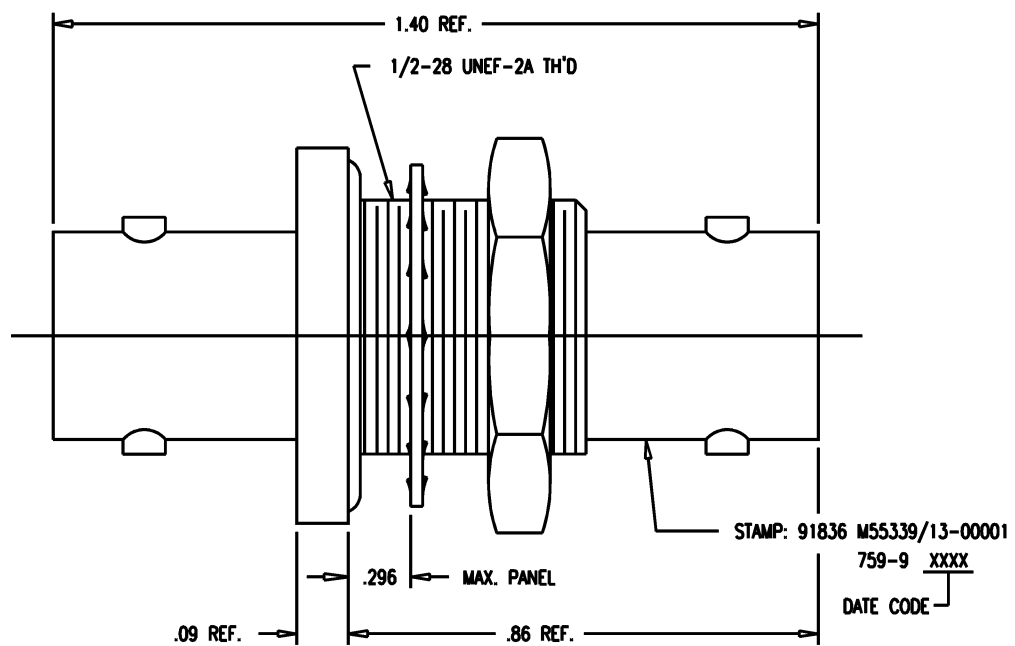

MOUNTING HOLE

- NOTES:
- INTERFACES PER MIL-STD-348, FIG. 301-2.
  - MATERIAL:  
 INSULATORS: TEFLON, ASTM-D-1457  
 O-RINGS: SIL. RUB., ZZ-R-765  
 LOCKWASHER: PHOS. BRONZE, QQ-B-750  
 CENTER CONTACT: BER. COP., ASTM-B-196  
 ALL OTHER PARTS: BRASS, ASTM-B16
  - FINISHES:  
 CENTER CONTACT: HARD GOLD PLATE PER MIL-G-45204  
 ALL OTHER METAL PARTS: SILVER PLATE PER QQ-S-365
  - ELECTRICAL CHARACTERISTICS:  
 NOMINAL IMPEDANCE: 50 OHMS  
 VOLTAGE RATING: 500 VRMS  
 FREQUENCY RANGE: DC TO 4 GHz
  - PRESSURE TEST: 30 PSI, 1 MIN.

UNLESS OTHERWISE SPECIFIED  
 1. ALL DIMENSIONS IN INCHES (MILLIMETERS).  
 2. TOLERANCES:  
 .xxx ±.004    .xx ±.010  
 [.xxx ±.10]   [.xx ±.25]  
 FRACTIONS: x/y ±.010 [.25]    ANGLES: ± 1°  
 ★ CRITICAL DIMENSIONS

M55339/13-00001

REVISIONS	
ISSUE	CHANGES
4	CN 35064 C REDRAWN JCA 11/22/93
5	CN 35618 D KH 01/09/95
G	ER 7595 BAM 04/15/08

CUSTOMER SALES DRAW

SCALE	4:1		
APPROX SURFACE AREA			
SD759-9			
USED ON			
REF:			
ADAPTER, F-F, BULKHEAD, PRESSURIZED, BNC-BNC			
DRAWN	JCA	DATE	11/22/93
DESIGN	LI	DATE	11/23/93
APPR.		DATE	

M55339/13-00001