

DASH NO.	M CODE	MADE FROM
----------	--------	-----------

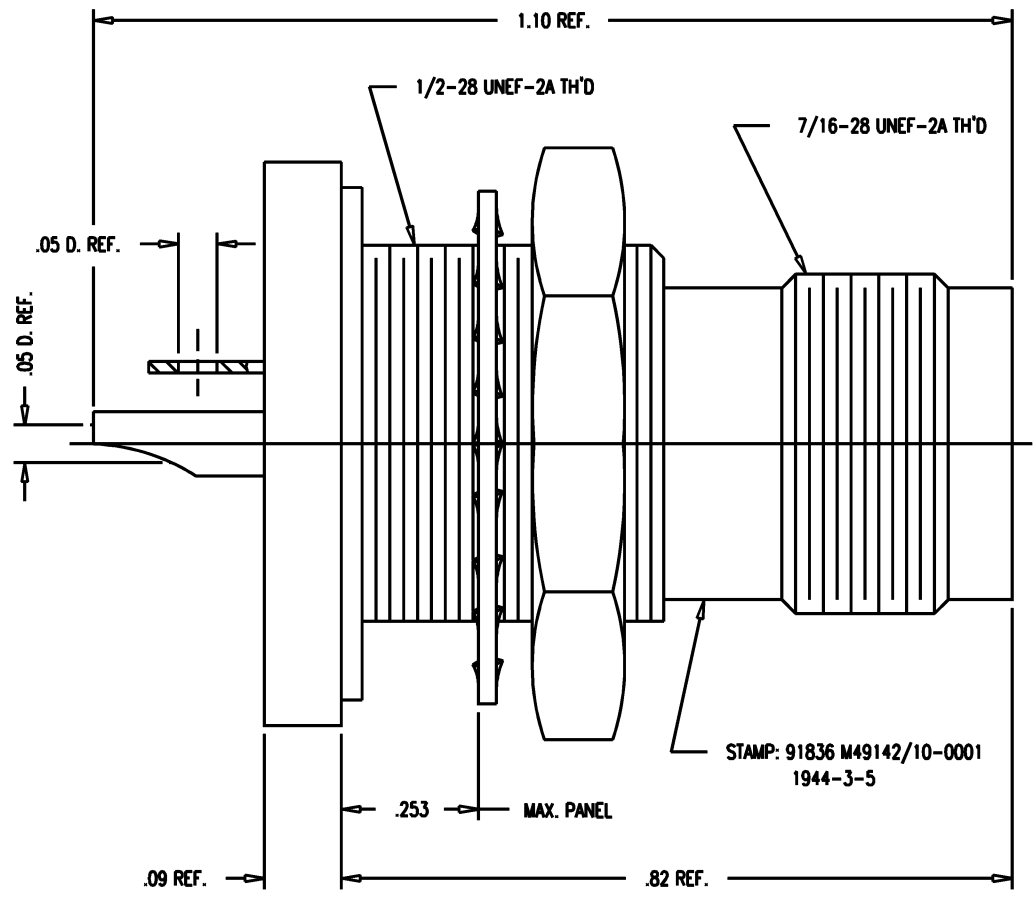

GSD

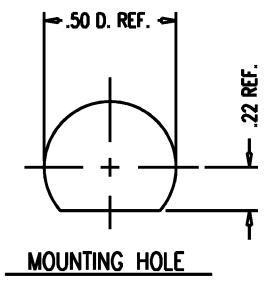
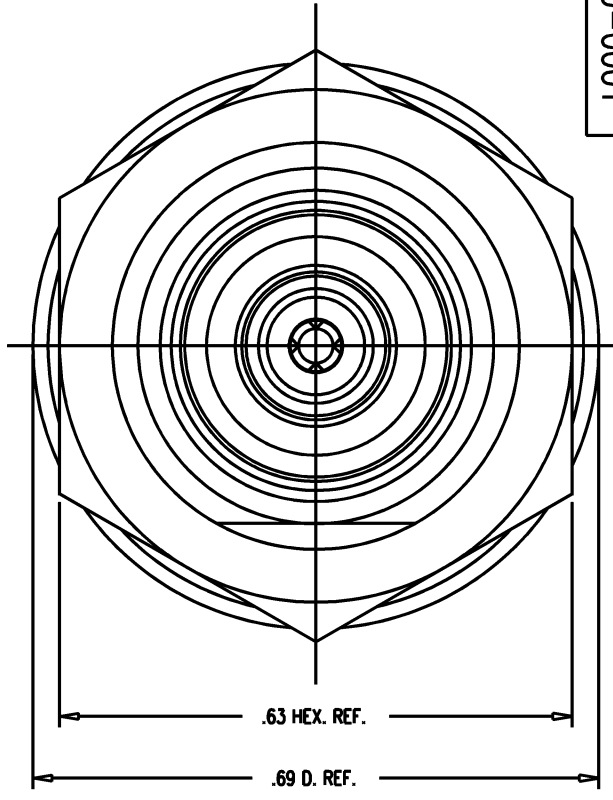

M49142/10-0001

REVISIONS	
ISSUE	CHANGES
5	CN 32735 A REDRAWN KH 12/06/90
6	CN 36666 C KH 11/14/95

GSD  
KAM077

SCALE	6:1
APPROX SURFACE AREA	1944-3-5
USED ON	
REF:	
RECEPTACLE, BULKHEAD, TRT	

DRAWN	KH	10/06/90
DESIGN	CT	12/06/90
APPR.	JT	03/06/91

**KINGS**  
ELECTRONICS CO., INC.  
TUCKAHOE, NEW YORK 10707

M49142/10-0001

NOTES:

1. MATERIALS:

- INSULATORS-TEFLON, ASTM-D-4894
- GASKET-SILICONE RUBBER, ZZ-R-765
- LOCKWASHER-PHOSPHOR BRONZE, ASTM-B-103
- CENTER CONTACT-BER. COP., ASTM-B-196
- ALL OTHER METAL PARTS-BRASS, ASTM-B16

2. FINISHES:

- CENTER CONTACT-GOLD PLATE PER MIL-G-45204
- ALL OTHER METAL PARTS-SILVER PLATE PER QQ-S-365

4. ELECTRICAL CHARACTERISTICS:

- WORKING VOLTAGE-400 VOLTS RMS
- FREQUENCY RANGE-DC TO 500 MHz

5. INTERFACE PER MIL-STD-348 FIG. 202-2.