

DASH NO.	DESCRIPTION	MADE FROM
----------	-------------	-----------

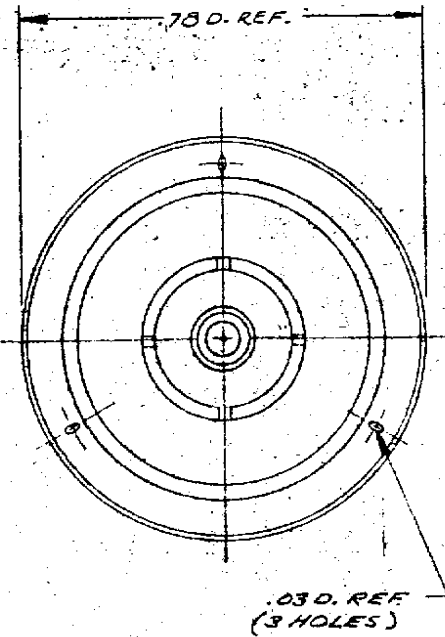
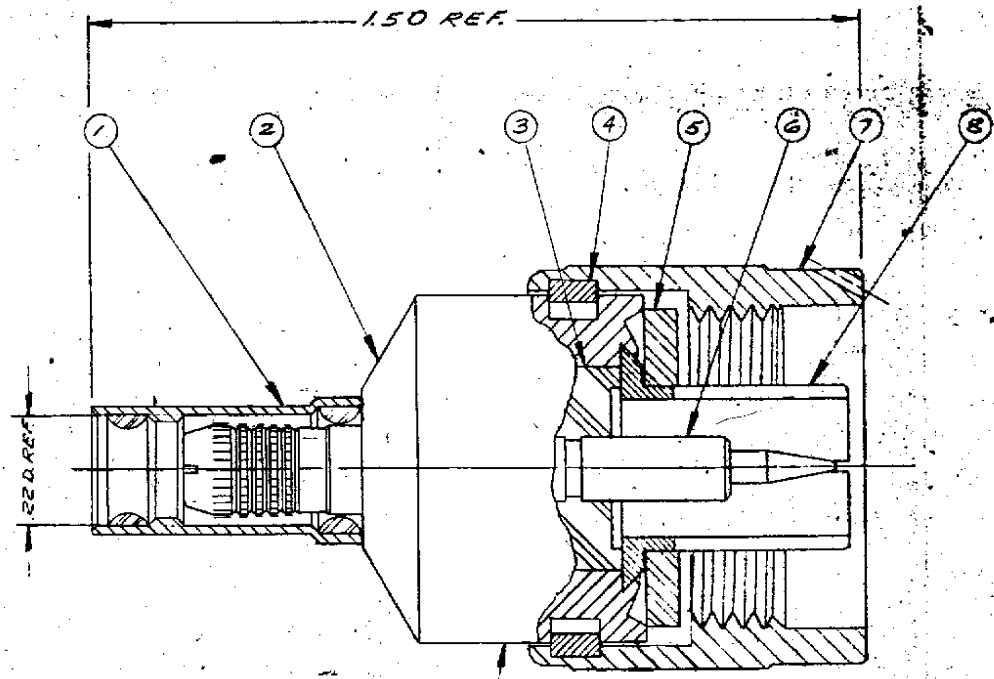

STAMP: KINGS KN-59-185

- NOTES:
1. FOR USE WITH BA-13077A, BA-14349 & MI 5206 CABLES.
 2. FOR CABLING INSTRUCTIONS SEE CP-5406.
 3. FOR CABLE TRIMMING, USE KTJ-160 & KTD-208.
 4. FOR FORMING USE CRIMP DIE SIZE 103.

UNLESS OTHERWISE SPECIFIED:

- | | |
|--|--|
| 1. TOLERANCES: FRACTIONS & 2 PLACE DECIMALS ± .010 | 2. REMOVE ALL BURRS, BREAK SHARP EDGES .005 MAX. |
| 3 PLACE DECIMALS ± .004 | 3. NO FILLETS PERMITTED. |
| T. I. R. CONCENTRICITY OF ANY 2 DIAMETERS MAY NOT EXCEED HALF THE SUM OF THEIR TOLERANCES. | 4. SURFACE ROUGHNESS 63 MICROINCHES RMS MAX. |
| | 5. ALL DIMENSIONS PRIOR TO PLATING. |

ITEM	REQ'D	DESCRIPTION	PART NO.
8	1	OUTER CONTACT	
7	1	COUPLING NUT	
6	1	NCAPTIVE CRIMP CONTACT	1-547-G-MB
5	1	GASKET	
4	1	C-RING	
3	1	INSULATOR	
2	1	K-GRIP BODY	
1	1	WPK GRIP SLEEVE	A-19-83-Z-MX

KN-59-185

REVISIONS	
REV#	CHANGES
0	ER 1499.5 JL 22 NOV 75
1	CN 15721C JHP 7 MAY 76
2	CN 16106 KNURL SHOWN K-GRIP SLEEVE SHORTENED JHP 23 JUL 76
3	CN 29012C AMD 16 JUN 87
4	CN 29609 E KH 16 FEB 88

USED ON:

REF:

FINISH:

SPEC:

MATL:

SPEC:

N PLUG

DRAWN JL DATE 7 NOV 75

APPD [Signature] DATE 22 NOV 75

KINGS ELECTRONICS
40 MARLBOROUGH ROAD
TUCKAHOE, N. Y. 10707

KN-59-185

S-D