

DASH NO. M CODE MADE FROM

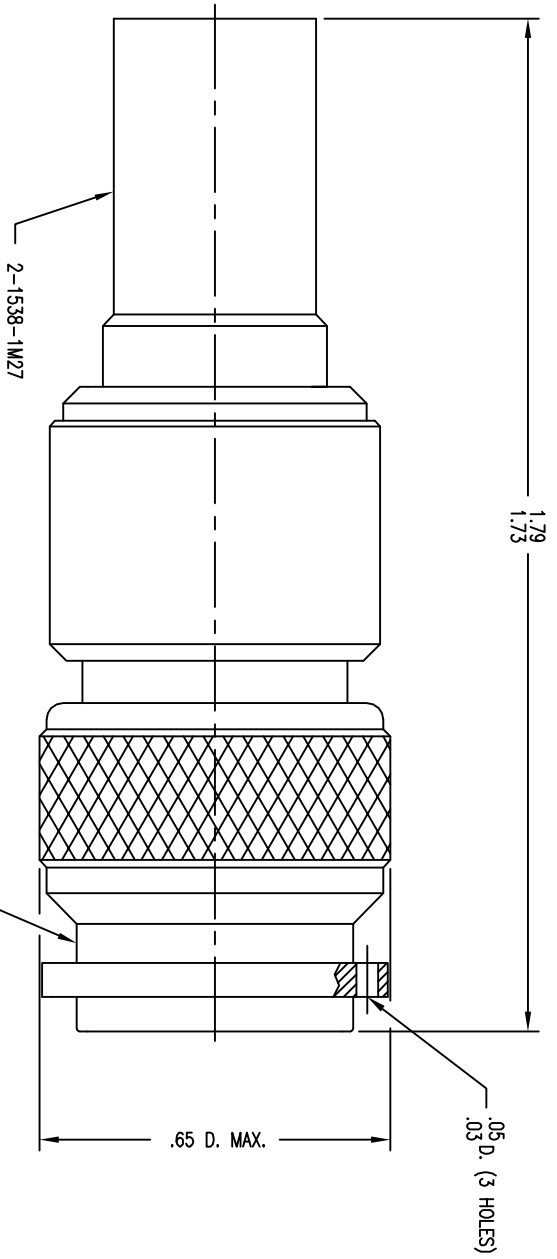

REVISIONS	
ISSUE	CHANGES
0	ER 33628 JCA 04/06/92
1	CN 34086 E MJB 08/19/92
2	ER 8354 RMS 05/29/08
D	ER 33571 COL 06/28/11

STAMP: KINGS 125-92-9

- NOTES:
- FOR USE WITH BOEING BMS13-65 QJ & ADAMS RUSSELL FC38Z CABLES.
 - FOR CABLING INSTRUCTIONS SEE 3-546-2.
 - FOR CRIMPING USE DIE KTH-2213.
 - INTERFACE PER MIL-STD-348, FIG. 313-1.
 - CENTER CONTACT (1-761-11MA9) SUPPLIED UNASSEMBLED.
 - MARK PACKAGE: KINGS 125-92-9
 - MATERIALS:
YRWK (DATE CODE)
 - INSULATOR: TEFLON, ASTM-D-1710
K-GRIP SLEEVE: COM. BRONZE TUBE, ASTM B135
OUTER CONTACT: BER. COPPER, ASTM-B-196
GASKET: SILICONE RUBBER, A-A-59588
C-RING: PHOSPHOR BRONZE, ASTM B103
ALL OTHER METAL PARTS: BRASS, ASTM-B16

- ELECTRICAL CHARACTERISTICS:
NOMINAL IMPEDANCE: 50 OHMS
WORKING VOLTAGE: 500 VRMS
FREQUENCY RANGE: DC TO 11 GHz
INSERTION LOSS: DC TO 2.5 GHz, 0.07 dB MAX
2.5 TO 3.5 GHz, 0.09 dB MAX
3.5 TO 5.0 GHz, 0.21 dB MAX
- WEIGHT: 28.375 GRAMS (0.063 POUNDS)

8. FINISHES:
CENTER CONTACT: .000050 MIN GOLD PER ASTM B488 OVER .000050 MIN NICKEL PER AMS-QQ-N-290(RoHS)
ALL OTHER METAL PARTS: .000050 MIN NICKEL PLATE PER AMS-QQ-N-290 OVER .000050 MIN COPPER PER ASTM B734(RoHS)

UNLESS OTHERWISE SPECIFIED

- ALL DIMENSIONS IN INCHES [MILLIMETERS].
- TOLERANCES:
XXX ±.004 XX ±.010
[.XX ±.10] [.XX ±.25]
FRACTIONS: X/Y ±.010 [.25]

★ CRITICAL DIMENSIONS ANGLES: ± 1°

125-92-9

SALES DRAWING

THIS DRAWING, THE DESIGN AND IDEAS EMPLOYED IN THE DESIGN AND CONSTRUCTION OF THE DRAWING, AND THE PROPERTY OF WINCHESTER ELECTRONICS CORPORATION AND SHALL NOT BE EMPLOYED, COPIED, OR DISCLOSED TO ANYONE IN ANY MANNER WITHOUT THE CONSENT OF WINCHESTER ELECTRONICS CORPORATION.

SCALE 4:1
APPROX SURFACE AREA
WAS: E-17336
USED ON
CAGE CODE:9183

DRAWN JCA		DATE 04/06/92
DESIGN JT		DATE 04/07/92
APPR.	DATE	

125-92-9

WINCHESTER
Winchester Electronics
1000 North Industrial
Road North
Wallingford, CT 06492

SIZE B