

# LEDEX



**ERMEC**  
Divisió Relojeria Monumental

ERMEC, S.L. BARCELONA  
C/ Francesc Teixidó, 22  
E-08918 Badalona  
(Spain)

Tel.: (+34) 902 450 160  
Fax: (+34) 902 433 088  
[ermec@ermec.org](mailto:ermec@ermec.org)  
[www.ermec.org](http://www.ermec.org)

ERMEC, S.L. MADRID  
C/ Sagasta, 8, 1ª planta  
E-28004 Madrid  
(Spain)

PORTUGAL  
[portugal@ermec.com](mailto:portugal@ermec.com)

 **JOHNSON  
ELECTRIC**

... innovating motion ...

The data used in this Product Overview may be used as a guideline only.  
Specific operational characteristics of our products may vary according to individual applications. It is strongly recommended that specific operating conditions are clarified with Johnson Electric before application.

Johnson Electric Terms and Conditions of Sale apply.

All data may be subject to change without notice.



ERMEC, S.L. BARCELONA  
C/ Francesc Teixidó, 22  
E-08918 Badalona  
(Spain)

Tel.: (+34) 902 450 160  
Fax: (+34) 902 433 088  
[ermec@ermec.org](mailto:ermec@ermec.org)  
[www.ermec.org](http://www.ermec.org)

ERMEC, S.L. MADRID  
C/ Sagasta, 8, 1ª planta  
E-28004 Madrid  
(Spain)

PORTUGAL  
[portugal@ermec.com](mailto:portugal@ermec.com)

# Table of Contents

## Johnson Electric Group

About Johnson Electric	2
About Ledex® Solenoids	4
Rotary Solenoid Overview	6
Linear Solenoid Overview	8
Value-Added Assemblies	12
Applications	14

## Innovations in Solenoid Technology

Overview	A2
MagShift®	A3
PMA™	A4
CamBolt™	A6

## Rotary Solenoids

Ultimag®	B
BTA®	C
Rotary	D

## Linear Solenoids

Soft Shift®	E
Tubular	F
Low Profile	G
Open Frame	H
Magnetic Latching	I

## Battery Operation and Electronics

Battery-Operated Solenoids	J
Electronic Drives and Coil Suppressors	K

## Resource Information

Technical Reference	L
Preferred Range Product Listing	M1
Index	M2

# LEDEX

*Ledex® is the world's leading industrial solenoid brand.*

*For more than 60 years, we have provided electromechanical and electromagnetic solutions where others cannot.*

*Our experienced team of design and production engineers solve problems for applications: from printers to defibrillators – from weapons systems to ATMs – from prison door locks to wastewater pump controls.*

*No matter what complexities or unique attributes your specific industrial actuation problem may contain, we are confident that Ledex Products can be your solution. We couple excellent customer service and delivery performance with our technical design advantage to provide you with a premium service experience in all aspects of your relationship with us.*

*We look forward to working with you.*



**ERMEC**  
División Relojería Monumental

ERMEC, S.L. BARCELONA  
C/ Francesc Teixidó, 22  
E-08918 Badalona  
(Spain)

Tel: (+34) 902 450 160  
Fax: (+34) 902 433 088  
[ermec@ermec.org](mailto:ermec@ermec.org)  
[www.ermec.org](http://www.ermec.org)

ERMEC, S.L. MADRID  
C/ Sagasta, 8, 1ª planta  
E-28004 Madrid  
(Spain)

PORTUGAL  
[portugal@ermec.com](mailto:portugal@ermec.com)

## The Johnson Electric Group is one of the world's largest providers of motion actuators for automotive and industrial applications

Over the years, we have shipped billions of motors to more than thirty countries in over one hundred different motor applications. Johnson Electric has an annual production capacity of one billion motors.

At the heart of Johnson Electric's success is our commitment to make our customers successful. Our customers include many of the world's leading industrial, consumer and automotive companies. We begin by understanding our customers' business needs, and the product application requirements of the end user of our customers' products. Then we design and deliver innovative motion solutions that help our customers to differentiate their products in the marketplace. Our goal is to be instrumental in the successful launch of our customers' products in their respective marketplaces.

### Our Brand Promise

#### Johnson Electric is the most reliable partner

Johnson Electric is responsive and flexible; and has the financial stability and organizational integrity

to meet all of our commitments and to support our customers' success. Product reliability and assurance of supply are our commitment.

### Johnson Electric delivers competitive advantage

Johnson Electric delivers differentiation and innovation through its motion products – subsystems comprising of Stepper Motors, DC Motors, AC Motors, Piezo-electric Motors, Switches, Solenoids, Flexi Circuits, Motion Control, Precision Plastics and Precision Gears.

Our business growth hinges with leading "branded" goods producers to deliver differentiation and innovation through our motion products. The core platform for delivering these solutions is a highly developed production base and focused customer support teams throughout the world. This combines scale advantages in production and procurement with skilled and dedicated motion application experts.



ERMEC, S.L. BARCELONA  
C/ Francesc Teixidó, 22  
E-08918 Badalona  
(Spain)

Tel.: (+34) 902 450 160  
Fax: (+34) 902 433 088  
[ermec@ermec.org](mailto:ermec@ermec.org)  
[www.ermec.org](http://www.ermec.org)

ERMEC, S.L. MADRID  
C/ Sagasta, 8, 1ª planta  
E-28004 Madrid  
(Spain)

PORTUGAL  
[portugal@ermec.com](mailto:portugal@ermec.com)

## HOW WE ARE ORGANIZED

**Johnson Electric Holdings Limited is the parent company of the Johnson Electric Group and has been listed on the Stock Exchange of Hong Kong since 1984. The Group structure consists of a number of operating divisions and business units focused on their particular customer application or product segment**

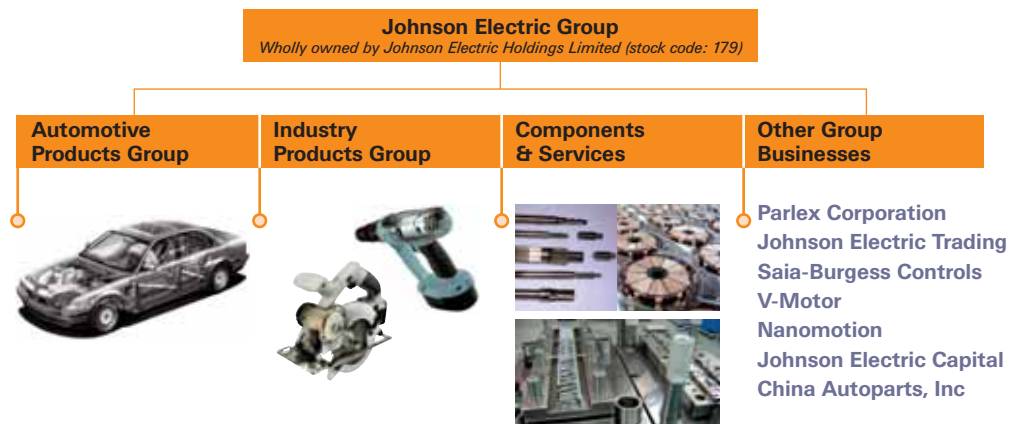

**The Group's motion systems, motors and switches businesses are managed through two primary operating divisions: Automotive Products Group and Industry Products Group.**

The Automotive Products Group, which consists of Johnson Electric's Automotive Motors Group and the Automotive Division of Saia-Burgess Electronics, is focused on providing customized motion solutions for major automotive application segments that include powertrain, body and chassis.

The Industry Products Group is comprised of business units that provide motion products and solutions for various commercial and industrial application sectors, including home appliances, power tools, business equipment, personal care products, medical equipment and healthcare, building automation and security, audio-visual and other industrial products.

Supporting these two operating divisions is the Group's Components & Services function which produces metal and plastic parts, tooling and production equipment for motor and motion related products. Johnson Electric is a highly vertically integrated business that manufactures an exceptionally wide range of components that form the basis for its final assembled end products. We make magnets, bearings, shafts, housings, laminations, commutators and die cast parts. We also build tools, assembly fixtures, plastic molds as well as armature winding and other production machines.

In addition to motion systems and motors, the Group also consists of a number of complementary manufacturing businesses and other subsidiary companies. These include an innovative provider of flexible printed circuits and interconnect solutions; a successful niche player in the programmable controls industry; and a rapidly growing specialty metals and trading services company.

# Ledex® Solenoid Solutions

Ledex® Solenoids are found in countless industrial applications from ATMs to zip code sorting machines.

Let our experience work for you.

Machine and process automation can range from the most basic on-off function to extremely complex sequencing. When the process involves linear or rotary motion, solenoids are among the best actuation devices in terms of size, cost, simplified installation, and ease of use.

Below and on the facing page are some of the primary functions which are ideally suited for Ledex® solenoids, followed by several pages of actual application examples of our products applied in a wide variety of industries. If your design includes linear or rotary operations, we can help you determine the best solenoid to meet your application design requirements.

## Exceptional Force or Torque

A linear solenoid can provide up to 133 N of force from a unit less than 60 mm long. A rotary solenoid can provide well over 11.3 Nm of torque from a unit also less than 60 mm inches long.

## Variable Positioning

Soft Shift® solenoids for linear applications and BTA® Brushless Torque Actuators for rotary applications provide variable positioning capabilities.

## High Speed

Solenoids can be actuated in milliseconds, or can be velocity controlled to provide smooth, noiseless actuation.

## Minimum Size

Need low profile? Minimum volume? Small frontal area? Ledex® solenoids can pack more work per cubic inch than motors.

## Simplified Control

Being a pulsed device with minimal components optimises solenoids for digital control. This results in faster cycling and higher reliability with fewer interfaces.

## Uncompromising Reliability

Ledex® solenoids provide repeatable, predictable performance with a specified life of up to 100 million cycles.

## Common Rotary Solenoid Applications

- Sorters
- Circuit breakers
- IC insertion machines
- Defibrillators
- Textile machinery
- Automatic tellers
- Blood analyzers
- Machine tools
- Pinch rollers
- Ticket machines
- Copiers

## Common Linear Solenoid Applications

- Vending machines
- Brakes
- Copiers
- Door locks
- Pumps
- Coin changers
- Film processors
- Disk drive locks
- Drug management systems

## Divert

Gate diverters, depending on the application, can be used continuously or very infrequently. In this example, a BTA® unit is chosen for its 100+ million actuation life rating.

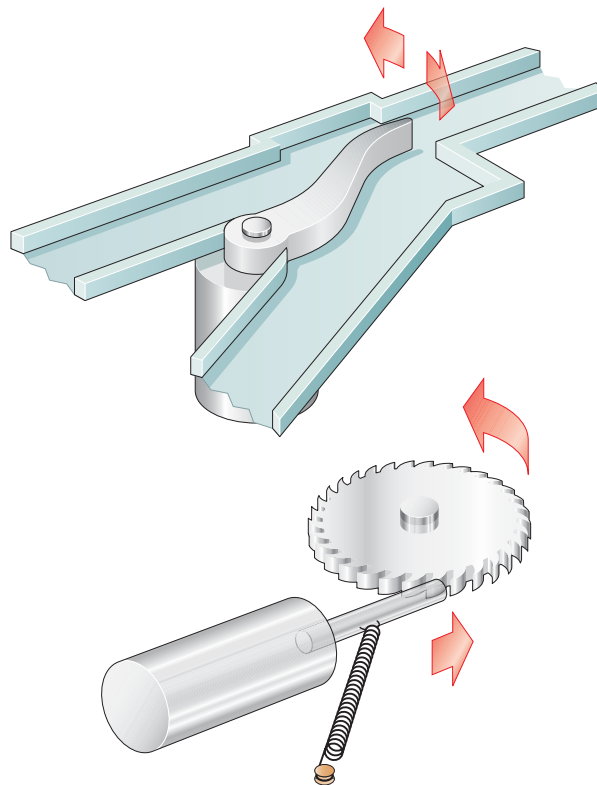

## Position

Positioning applications can range from a simple ratcheting device, such as this, to precise variable positioning using linear Soft Shift® solenoids or rotary BTA® actuators.

### Pinch

In medical equipment, tubes carrying body fluids must have accurately controlled flow regulation. In this example, a Soft Shift® solenoid is utilised for its variable positioning capability to smoothly pinch the tube to the operator's precise demand. Using a solenoid in this manner eliminates valves and other connecting apparatus which pose a threat for contamination or leakage.

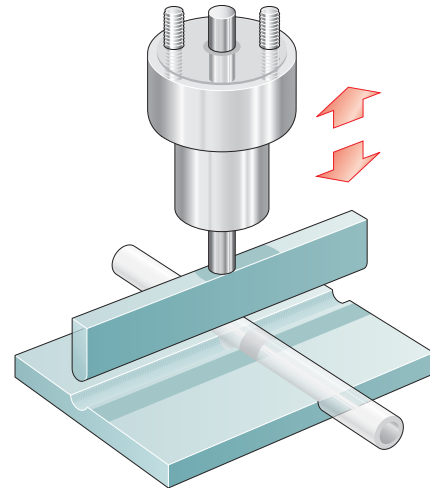

### Kick

Solenoid snap-acting response and electric operation are beneficial for part rejection processes in which electronic interfacing with a photosensor or some other sensor is required.

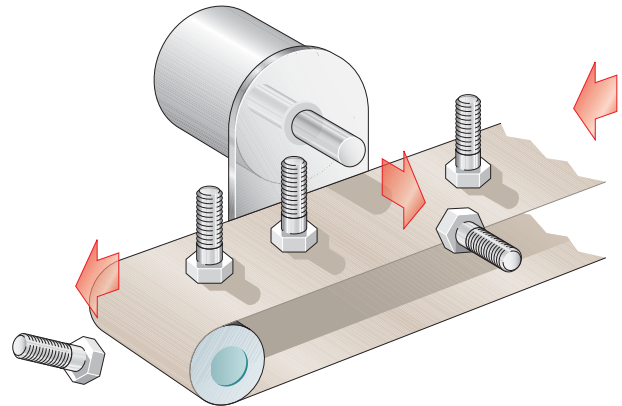

### Lock/Latch

Low cost, compact size, reliability, and long life are all reasons for the growing demand for Ledex solenoids in a wide variety of locking applications from vault doors, cash registers, disk drives and missile systems.

Whether rotary or linear, a Ledex solenoid is easily configured into machine designs requiring a platform or stage to be latched in position during a particular machine process.

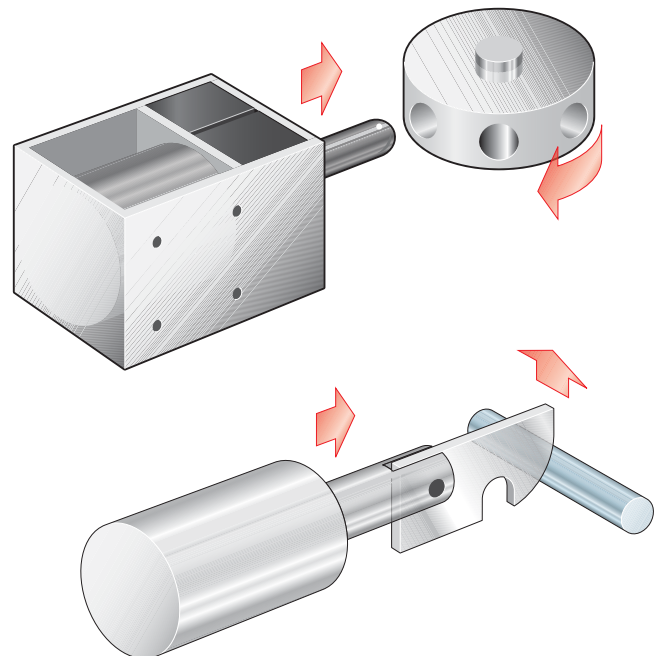

# Rotary Solenoids

**ERMEC**

Distribución de componentes eléctricos y electrónicos

Tel.: (+34)902.450.160

Fax: (+34)902.433.088

[info@ermec.com](mailto:info@ermec.com)

[www.ermec.com](http://www.ermec.com)

## Ultimag® Actuators

- Characteristics
- Quiet, shock-free operation
  - Fast energizing time
  - High speed cycle rates
  - On/off or proportional mode operation



Model	4EM	5EM	6EM
Dimensions (mm)	Ø41 x 26	Ø49 x 31	Ø59 x 41
Duty Cycle	Continuous or intermittent	Continuous or intermittent	Continuous or intermittent
Stroke	±22.5°	±22.5°	±22.5°
Net Starting Torque (Nm)	0.33	0.71	1.58
Speed (Hz)	>78	>67	>12.8
Life	100 million cycles	100 million cycles	100 million cycles
Power (W)	14.5–145	42–210	32–320
Supply (V)	3.2–115	6.6–168	9.2–313
Housing	Completely enclosed design	Completely enclosed design	Completely enclosed design

## BTA® Actuators

- Characteristics
- Quiet, shock-free operation
  - High speed cycle rates
  - Closed loop velocity
  - Position control



Model	2EVM ●	3EVM	4EVM	5EVM	6EVM
Dimensions (mm)	Ø30 x 18	Ø35 x 23	Ø41 x 27	Ø49 x 32	Ø59 x 41
Duty Cycle	Continuous or intermittent	Continuous or intermittent	Continuous or intermittent	Continuous or intermittent	Continuous or intermittent
Stroke	45°	45°	45°	45°	45°
Gross Starting Torque (Nm)	0.1	0.2	0.3	0.6	1.5
Life	100 million cycles	100 million cycles	100 million cycles	100 million cycles	100 million cycles
Power (W)	20–100	13–130	14.5–145	21–210	32–320
Supply (V)	3.1–80	1.9–78.7	3.2–115	4.7–168	9.2–313
Housing	Completely enclosed design	Completely enclosed design	Completely enclosed design	Completely enclosed design	Completely enclosed design

- Well-suited for battery operation.



All catalogue products manufactured after April 1, 2006 are RoHS Compliant

# Rotary Solenoids

**ERMEC**

Distribución de componentes eléctricos y electrónicos

Tel.: (+34)902.450.160

Fax: (+34)902.433.088

[info@ermec.com](mailto:info@ermec.com)

[www.ermec.com](http://www.ermec.com)

## Ledex® Rotary Solenoids

- Characteristics
- Snap acting engagement
  - Maximum versatility
  - On/off operation
  - Clockwise or counterclockwise



Model	1E ●	2E ●	3B	3E
Dimensions (mm)	Ø25 x 16	Ø29 x 17	Ø33 x 22	Ø33 x 20
Duty Cycle	Continuous or intermittent	Continuous or intermittent	Continuous or intermittent	Continuous or intermittent
Stroke	Up to 45°	Up to 45°	Up to 67.5°	Up to 67.5°
Starting Torque (mNm)	Up to 124	Up to 192	Up to 362	Up to 362
Holding Torque (mNm)	Up to 32	Up to 56	Up to 102	Up to 102
Life	1 million cycles; 50 million cycles on extended life types	1 million cycles; 50 million cycles on extended life types	1 million cycles; 50 million cycles on extended life types	1 million cycles; 50 million cycles on extended life types
Power (W)	10.5–108	7–140	10–200	9–180
Supply (V)	2.9–94	2.2–128	2.6–123	2.6–118
Housing	Compact design with a variety of enclosures	Compact design with a variety of enclosures	Compact design with a variety of enclosures	Compact design with a variety of enclosures

Model	4E	5B	5S	6S	7S
Dimensions (mm)	Ø40 x 24	Ø48 x 26	Ø48 x 27	Ø57 x 34	Ø70 x 45
Duty Cycle	Continuous or intermittent	Continuous or intermittent	Continuous or intermittent	Continuous or intermittent	Continuous or intermittent
Stroke	Up to 95°	Up to 95°	Up to 110°	Up to 110°	Up to 95°
Starting Torque (mNm)	Up to 588	Up to 1130	Up to 1492	Up to 3457	Up to 5265
Holding Torque (mNm)	Up to 226	Up to 452	Up to 565	Up to 1017	Up to 2260
Life	1 million cycles; 50 million cycles on extended life types	1 million cycles; 50 million cycles on extended life types	1 million cycles; 50 million cycles on extended life types	1 million cycles; 50 million cycles on extended life types	1 million cycles; 50 million cycles on extended life types
Power (W)	12.5–250	21–420	21–420	32–640	35–700
Supply (V)	4.3–187	6.1–273	6.1–271	10.3–469	16.3–463
Housing	Compact design with a variety of enclosures	Compact design with a variety of enclosures	Compact design with a variety of enclosures	Compact design with a variety of enclosures	Compact design with a variety of enclosures

- Well-suited for battery operation.



All catalogue products manufactured after April 1, 2006 are RoHS Compliant

# Linear Solenoids

## Soft Shift® Solenoids

- Characteristics
- Quiet operation
  - Slow, smooth motion
  - Snap action
  - On/off or velocity controlled



**ERMEC**

Distribución de componentes eléctricos y electrónicos

Tel.: (+34)902.450.160

Fax: (+34)902.433.088

[info@ermec.com](mailto:info@ermec.com)

[www.ermec.com](http://www.ermec.com)

Model	2EPM ●	3EPM	4EPM	5EPM	6EPM
Dimensions (mm)	Ø29 x 25	Ø33 x 31	Ø40 x 37	Ø48 x 49	Ø57 x 56
Duty Cycle	Continuous or intermittent	Continuous or intermittent	Continuous or intermittent	Continuous or intermittent	Continuous or intermittent
Stroke (mm)	Up to 4.1	Up to 0.6.4	Up to 0.7.6	Up to 10.2	Up to 10.7
Force (N)	Up to 17	Up to 19	Up to 33	Up to 56	Up to 131
Life	10 million cycles	10 million cycles	10 million cycles	10 million cycles	10 million cycles
Power (W)	7–70	9–90	12.5 x 125	21– 210	21– 210
Supply (V)	2.2–91	2.6–83	4.3 x 132	7.2–226	7.2–226
Housing	Completely enclosed design	Completely enclosed design	Completely enclosed design	Completely enclosed design	Completely enclosed design

## Tubular Solenoids

- Characteristics
- Push or pull operation
  - Well-suited to lock/latch operations
  - Multiple plunger designs
  - On/off operation



Model	13 x 14 ●▲	13 x 27 ●	20 x 40 ●	26 x 52	Size 125M	Size 150M	Size 175M
Dimensions (mm)	Ø13 x 14	Ø13 x 27	Ø20 x 40	Ø26 x 52	Ø32 x 57	Ø38 x 64	Ø45 x 120
Duty Cycle	Continuous or intermittent	Continuous or intermittent	Continuous or intermittent	Continuous or intermittent	Continuous or intermittent	Continuous or intermittent	Continuous or intermittent
Stroke (mm)	Up to 2.5	Up to 12	Up to 17	Up to 17	Up to 19	Up to 19	Up to 64
Force (N)	Up to 4	Up to 4	Up to 12	Up to 23	Up to 29	Up to 43	Up to 29
Life	25 million cycles	25 million cycles	25 million cycles	25 million cycles	1 million cycles	1 million cycles	1 million cycles
Power (W)	3–30	4–40	7–70	10–100	13–130	17–170	20–200
Supply (V)	1.2–38	2.4–77	3.9–76	4.4–142	6.8–128	9.8–315	17–534
Housing	Shock and vibration integrity	Shock and vibration integrity	Shock and vibration integrity	Shock and vibration integrity	Shock and vibration integrity	Shock and vibration integrity	Shock and vibration integrity

● Well-suited for battery operation.

▲ Magnetic Latching available.

All catalogue products manufactured after April 1, 2006 are RoHS Compliant

# Linear Solenoids

## Low Profile Solenoids

- Characteristics
- Push/pull engagement
  - High force
  - Short stroke applications
  - On/off operation



**ERMEC**  
 Distribución de componentes eléctricos y electrónicos  
 Tel.: (+34)902.450.160  
 Fax: (+34)902.433.088  
[info@ermec.com](mailto:info@ermec.com)  
[www.ermec.com](http://www.ermec.com)

Model	0ECM ●	1ECM ●	2EFM/2ECM ●	3EFM/3ECM
Dimensions (mm)	Ø19 x 12.7	Ø25.5 x 13.5	Ø28.6 x 14.7	Ø33.3 x 17.5
Duty Cycle	Continuous or intermittent	Continuous or intermittent	Continuous or intermittent	Continuous or intermittent
Stroke (mm)	Up to 3.8	Up to 6	2EF: Up to 1.8 2EC: Up to 6.1	3EF: Up to 1.8 3EC: Up to 7.6
Force (N)	Up to 9	Up to 14	2EF: Up to 60 2EC: Up to 17	3EF: Up to 89 3EC: Up to 24
Life	1 to 5 million cycles	1 to 5 million cycles	1 to 5 million cycles	1 to 5 million cycles
Power (W)	4.5–45	5–50	7–70	9–90
Supply (V)	1.6–78	2.1–83	2.2–56	2.6–83
Housing	Completely enclosed design	Completely enclosed design	Completely enclosed design	Completely enclosed design

Model	4EFM/4ECM	5SFM/5ECM	6SFM/6ECM	7ECM	8ECM
Dimensions (mm)	Ø39.7 x 21.2	5SF: Ø47.6 x 22.4 5EC: Ø47.6 x 26.3	6SF: Ø57.2 x 29.1 6EC: Ø57.2 x 33.8	Ø69.9 x 45.2	Ø85.7 x 55.0
Duty Cycle	Continuous or intermittent	Continuous or intermittent	Continuous or intermittent	Continuous or intermittent	Continuous or intermittent
Stroke (mm)	4EF: Up to 3.0 4EC: Up to 6.4	5SF: Up to 3.6 5EC: Up to 10.2	6SF: Up to 4.6 6EC: Up to 10.2	Up to 17.8	Up to 17.8
Force (N)	4EF: Up to 113 4EC: Up to 51	5SF: Up to 173 5EC: Up to 94	6SF: Up to 356 6EC: Up to 191	Up to 240	Up to 645
Life	1 to 5 million cycles	1 to 5 million cycles	1 to 5 million cycles	1 to 5 million cycles	1 to 5 million cycles
Power (W)	12.5–125	21–210	32–320	35–350	41–410
Supply (V)	4.3–132	5SF: 6.1–192 5EC: 7.2–226	6SF: 10.3–331 6EC: 12.3–394	19–600	29–529
Housing	Completely enclosed design	Completely enclosed design	Completely enclosed design	Completely enclosed design	Completely enclosed design

- Well-suited for battery operation.



All catalogue products manufactured after April 1, 2006 are RoHS Compliant

## Linear Solenoids

### Box Frame Solenoids

- Characteristics
- Pull-in operation (push types available)
  - Higher efficiency
  - On/off operation
  - Continuous or intermittent duty



Model	B4HDM	B11M	B14M●/B14M-L●▲	B16M●/B16M-L●▲	B17M●/B17M-L●▲
Dimensions H x W x L (mm)	41.4 x 36.8 x 55.4	30.0 x 23.9 x 47.2	25.9 x 20.1 x 36.8	12.2 x 9.8 x 25.1	15.0 x 13.0 x 24.1
Duty Cycle	Continuous or intermittent	Continuous or intermittent	Continuous or intermittent	Continuous or intermittent	Continuous or intermittent
Stroke (mm)	Up to 25	Up to 25	Up to 15	Up to 4	Up to 4.5
Force (N)	Up to 102	Up to 31	Up to 24	Up to 4	Up to 7
Life	50,000 to 100,000 cycles	50,000 to 100,000 cycles	50,000 to 100,000 cycles	50,000 to 100,000 cycles	50,000 to 100,000 cycles
Power (W)	1.4–190	1.4–190	5.2–52.2	1.4–190	1.4–190
Supply (V)	6–388	6–388	6–76	6–388	6–388
Housing	Box frame	Box frame	Box frame	Box frame	Box frame

Model	B20M ●	B21M	B22M/B22M-L ▲	B27M	B41M	B75M ●
Dimensions H x W x L (mm)	23.9 x 20.6 x 29.0	33.3 x 33.3 x 30.5	37.3 x 33.3 x 40.9	28.9 x 25.4 x 41.4	51.6 x 43.9 x 77.5	27.9 x 25.4 x 41.4
Duty Cycle	Continuous or intermittent	Continuous or intermittent	Continuous or intermittent	Continuous or intermittent	Continuous or intermittent	Continuous or intermittent
Stroke (mm)	Up to 12.5	Up to 12.5	Up to 25	Up to 10	Up to 25	Up to 15
Force (N)	Up to 27	Up to 55	Up to 66	Up to 31	Up to 140	Up to 53
Life	50,000 to 100,000 cycles	50,000 to 100,000 cycles	50,000 to 100,000 cycles	50,000 to 100,000 cycles	50,000 to 100,000 cycles	50,000 to 100,000 cycles
Power (W)	4.5–45	9–80	1.4–190	7–72	1.4–190	6–60
Supply (V)	6–388	6–388	6–388	6–388	6–388	6–153
Housing	Box frame	Box frame	Box frame	Box frame	Box frame	Box frame

● Well-suited for battery operation.

▲ Magnetic Latching model.

All catalogue products manufactured after April 1, 2006 are RoHS Compliant

# Linear Solenoids

## C Frame Solenoids

- Characteristics
- Pull-in operation (push types available)
  - Most economical
  - On/off operation
  - Continuous or intermittent duty



### ERMEC

Distribución de componentes eléctricos y electrónicos

Tel.: (+34)902.450.160

Fax: (+34)902.433.088

[info@ermec.com](mailto:info@ermec.com)

[www.ermec.com](http://www.ermec.com)

Model	C5M ● / C5M-L ●▲	C8M ●	C9M ●	C15M
Dimensions H x W x L (mm)	11.7 x 10.4 x 23.9	20.6 x 19.1 x 28.7	31.8 x 35.1 x 26.9	25.4 x 26.9 x 29.0
Duty Cycle	Continuous or intermittent	Continuous or intermittent	Continuous or intermittent	Continuous or intermittent
Stroke (mm)	Up to 5	Up to 12.5	Up to 12.5	Up to 12.5
Force (N)	Up to 5	Up to 16	Up to 29	Up to 15
Life	50,000 to 100,000 cycles	50,000 to 100,000 cycles	50,000 to 100,000 cycles	50,000 to 100,000 cycles
Power (W)	3–30	1.4–190	1.4–190	1.4–190
Supply (V)	3–76	6–388	6–388	6–388
Housing	C frame	C frame	C frame	C frame

Model	C26M	C33M	C34M
Dimensions H x W x L (mm)	26.9 x 21.6 x 43.9	29.0 x 33.3 x 34.5	36.5 x 33.3 x 42.2
Duty Cycle	Continuous or intermittent	Continuous or intermittent	Continuous or intermittent
Stroke (mm)	Up to 19	Up to 12.5	Up to 25
Force (N)	Up to 14	Up to 29	Up to 57
Life	50,000 to 100,000 cycles	50,000 to 100,000 cycles	50,000 to 100,000 cycles
Power (W)	1.4–190	1.4–190	1.4–190
Supply (V)	6–388	6–388	6–388
Housing	C frame	C frame	C frame

- Well-suited for battery operation.



- ▲ Magnetic Latching model.

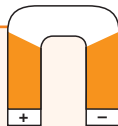

All catalogue products manufactured after April 1, 2006 are RoHS Compliant

# Looking for a specialised solenoid solution?

## Look no further.

We offer the industry's most comprehensive combination of technology, engineering and manufacturing to satisfy all your actuation design needs. From stand-alone solenoid products to complete value-added solutions; we can do it all for you. The images shown are just a few examples of our design and value-added sub-assembly capabilities.

We look forward to the opportunity to work with you.

**ERMEC**

Distribución de componentes eléctricos y electrónicos

Tel.: (+34)902.450.160

Fax: (+34)902.433.088

[info@ermec.com](mailto:info@ermec.com)

[www.ermec.com](http://www.ermec.com)

## Ledex® Value-Added Sub-Assemblies

We specialise in the production of custom sub-assemblies, not just solenoids. The following example is typical of what we do to add value for our customers every day:

### Customer Request:

Our customer had a demanding application for a complete solenoid sub-system including drive electronics, surge suppression, and a feedback sensor.

### Ledex® Solution:

We designed a complete system solution for the customer in a matter of weeks from concept to completion.

Completed units are tested, packaged, and shipped to the customer ready for easy installation.

Materials for this assembly include:

STA Tubular Solenoid PLUS . . .



- Bracket • Adaptor • Spring • Hex Nut • Optical Sensor
- Connector and Cable • PCB • PC Cable • Actuator Arm
- Stand Offs • Trans. Voltage Suppression • Housing

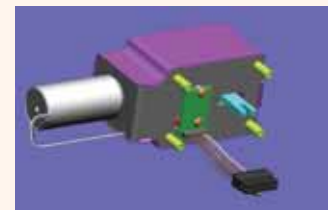
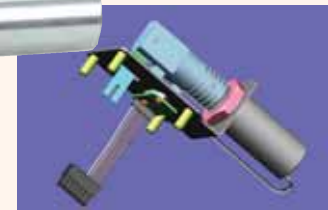
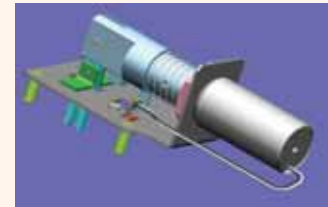
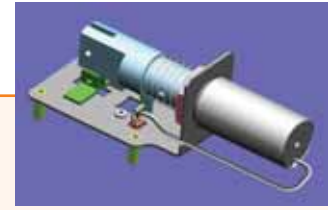
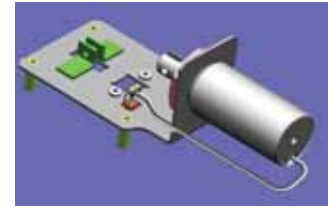
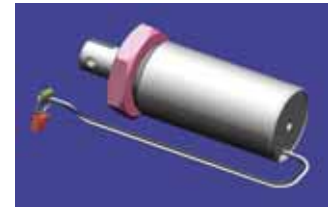

# Ledex® Value-Added Solenoid Assemblies



Rotary solenoid with special armature actuator arm and connector



Special open frame solenoid with built-in special mounting plate, actuator arm and spring cushioned stroke-limiting stops



BTA® actuator with integral mounting adapter, diverter vane and return spring



Dual solenoid assembly with diecast mounting bracket and connectors, modified shafts with cross drilled holes for mounting attachments



Rotary solenoid with special armature arm, mounting plate, spring shock mounts and connector with ground wire



Linear solenoid with spring return and molded plastic mounting adapter and actuator arm



Soft Shift® linear variable positioning solenoid with heavy duty external spring



Low profile linear solenoid with special mounting base including locator pins and special leadwire exit location with connector



Linear solenoid with integral mounting adapter and connector, noise absorbing stop and rubber plunger button



Special square linear solenoid with shock mounted foot bracket and manual override



Low profile solenoid with special mounting plate and wiring termination



Tubular solenoid with special mounting plate with built-in stop and connector

# Ledex® Application Examples

## Pharmaceutical and Medical Equipment

The quality and reliability of Ledex® solenoids make them the ideal solution for medical automation

- Precise, clean, quiet, reliable automation of medical equipment functions
- Compact size with high force or torque
- Easy control with simple electronics
- Instant actuation or smooth variable positioning
- High MTBF, reliable, repeatable operation without degradation due to wear
- Long, predictable life (10<sup>6</sup> cycles)
- Ideal for both open loop or closed loop microprocessor controlled systems



### Pharmaceutical Dispenser

- Storage tray locks
- Locks individual medicine compartments
- Counts tablets as dispensed

### IV Fluid Metering

- As pinch valves, solenoids offer a simple, direct, reliable means to start and stop fluid flow through valves or tubing
- Design advantages include non-contacting, quiet operation with minimal heat generation
- Depending on the design requirements, either immediate on/off or slow, proportional actuation can be achieved

### Intraocular Microsurgery

- Low profile solenoids are used to control fluid flow through a series of tubes for intraocular surgery
- Reliability is a primary solenoid advantage to eliminate the possibility of malfunction during surgery

### Portable, Real-Time Blood Analyzer

- A bedside blood analyzer allows blood to be monitored during administration of medicines allowing doctors to prescribe medications in more exacting dosages based on the patient's condition
- A series of tubular solenoids are used to automate these testing functions with higher repeatability than if done manually.

### X-Ray Processor

- For a fully automatic X-ray film development machine, a tubular solenoid activates a lever with suction cups to grip individual sheets of film for processing as they are required
- Being electrically actuated eliminated compartment contamination which would occur if pneumatics were used

### Autotransfusion Machine

- Solenoids replaced a DC gearmotor and cam mechanism to operate the series of pinch valves which are opened and closed to accommodate the various blood processing functions
- In addition to performance, patient and operator safety is a paramount design criteria
- Not only do solenoids provide added safety in a power interruption situation, but they dramatically simplify the system design, minimise the number of moving parts, and reduce system cost

### Surgical Laser

- Solenoids are commonly used as the shutter mechanism for surgical lasers

### Portable Steam Instrument Steriliser

- Unlike the sophisticated static sterilisers in major hospitals and clinics, many remote facilities rely on the traditional method of boiling instruments. For these applications, a compact field-portable steriliser pressure boils the instruments in a third as much time and with better results
- A tubular solenoid equipped with high temperature PTFE leads operates the lid interlock mechanism
- This compact interlock ensures that the sterilization sequence cannot commence unless the lid is properly closed, and that once commenced, the lid cannot be opened until the sterilization cycle is either completed or deliberately canceled

### Ventilator

- Ultimag® bidirectional solenoids operate a two-way valve in a ventilator
- The oscillatory operation of the device is ideal for creating a positive air pressure to the patient during inhalation and an open vent during exhalation
- Using a simple bipolar PWM signal, the actuator activates to its inhalation position in 10 ms, is held in position for two seconds, then reverse rotated to the exhale position (-80°), held two seconds, then back to inhale position (+80°) for an indefinite operating cycle period

# Ledex® Application Examples

## Residential and Commercial Circuit Breakers

Ledex® solenoids are used on numerous residential and commercial circuit breaker applications

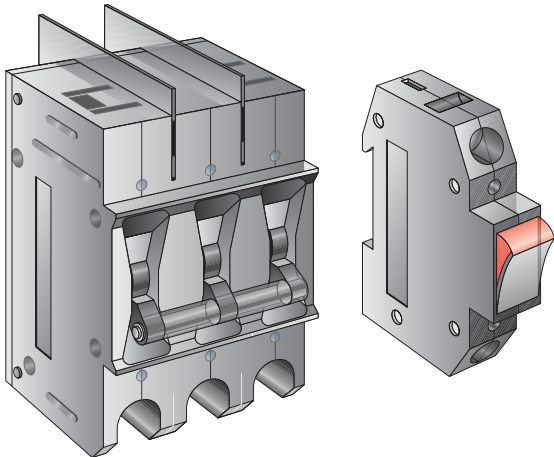

### Heavy Duty Industrial Breakers

- Used in industrial applications for switching heavy loads
- New magnetically latching designs

### Molded Case Breakers

- Similar to residential single and double pole breakers

### Re-closers

- Oil or vacuum filled high voltage breakers

### Residential Circuit Breakers

- Most commonly use low cost open frame solenoids to trip breaker
- Some applications require magnetically latching open frame models

### Industrial Breakers

- Large solenoids are typically used for industrial applications due to the higher switching loads

## High Speed Sorting

Ledex® solenoids offer state-of-the-art actuation solutions for today's high speed sorting applications

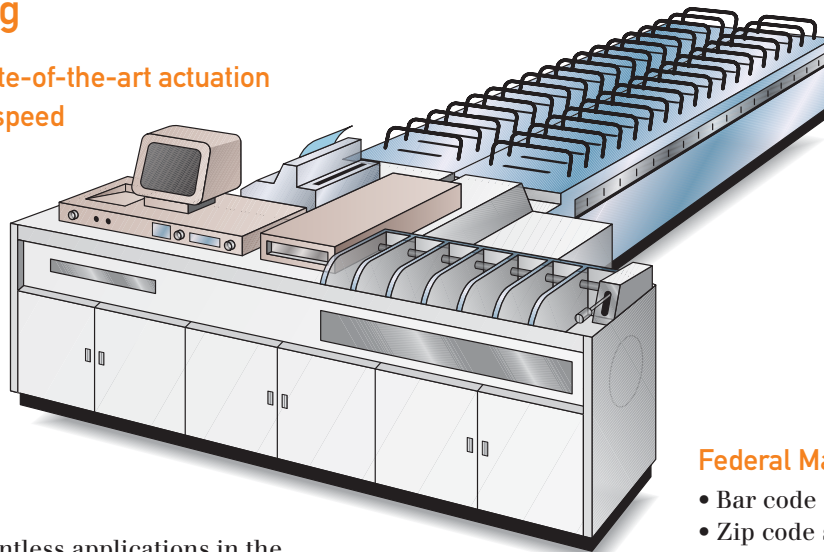

Solenoids are found in countless applications in the commercial and Federal mail processing industry. Whether it is a very large machine found in a major U.S. Postal Service facility or a machine found at a credit card statement processing centre, these high speed sorters contain many solenoids. Rotary solenoids are typically used to actuate sorting gates. Linear solenoids are often used in accumulators and feeders.

### Commercial Mail Processing

- High speed flat sorters
- Parcel sorters
- Envelope preparation
- Accumulators
- Diverters
- Stamping/metering
- Mixed mail variety sorting
- Drive belt tensioning

### Federal Mail Processing

- Bar code sorters
- Zip code specific diverter gates
- Mail tray horizontal stack pusher
- Optical recognition character reader/sorter
- Conveyor systems
- Lights out/unmanned bulk mail sort system
- Automated tray management systems
- Rail and tilt cars
- Mail bucket lever trip mechanisms

# Ledex® Application Examples

## Office Automation

Ledex® solenoids serve the diverse needs of the worldwide office automation market

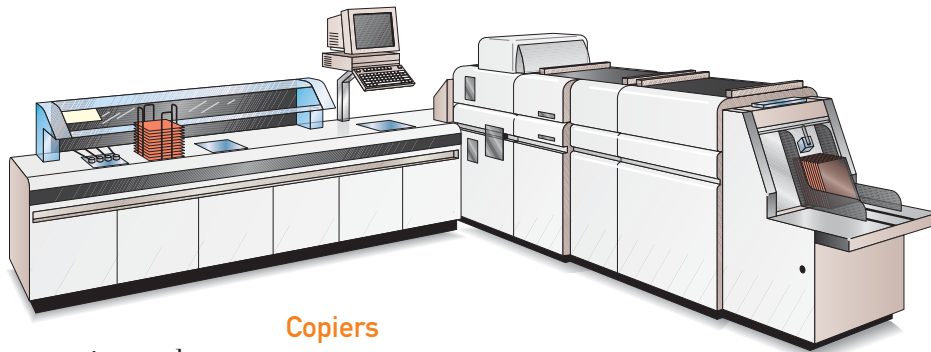

In the world of office automation, computers and peripherals, solenoids are prevalent. Their long life and quiet actuation characteristics suit them ideally for office environments. Whether it is a PC, a printer, a data storage device, or any number of office automation machines, we have a long history and a wealth of design experience for this industry.

### Copiers

- Paper feed
- Film advance
- Toner positioning
- Registration marking

### Data Storage

- Door lock in drive cartridges
- Head lock
- Tape library index lock
- X-ray copier/image storage

### Printers

- Envelope conditioner
- Paper cutter
- Ticket cutter for airline tickets, lottery tickets...
- ATM receipt
- Paper feed mechanism
- Paper drawer feed selector

## Locking Mechanisms

Ledex® solenoids put the lock in security technology

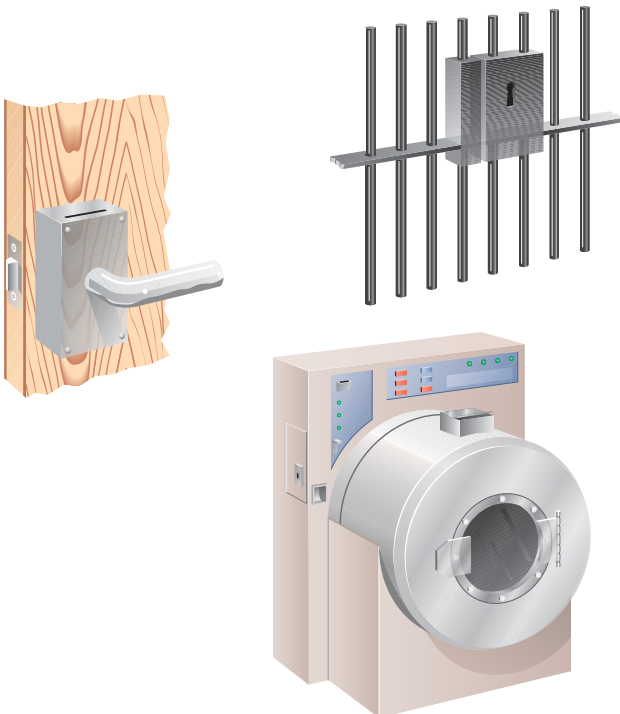

Ledex® solenoids are found in numerous applications that require a locking device. Whether it is a medical application, an office automation application or a door lock, solenoids provide an effective, cost-efficient locking mechanism.

### Security Applications

- Hotel room door lock
- Hotel safe lock
- Prison door lock
- Fire safety door opening lock

### Office Automation

- Disk drive door lock
- Personal computer chassis lock
- Docking station lock
- Locks to hold peripherals in place
- Tape library index lock

### Medical

- Steriliser lock
- Centrifuge lock
- Blood analysis machine lock

### Industrial

- Overhead door lock
- Fire safety door lock
- Prison locks
- Commercial laundry locks

## Ledex® Innovations in Solenoid Technology

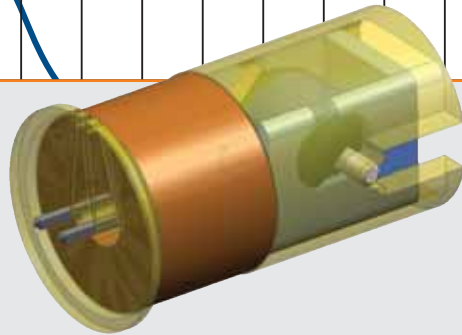
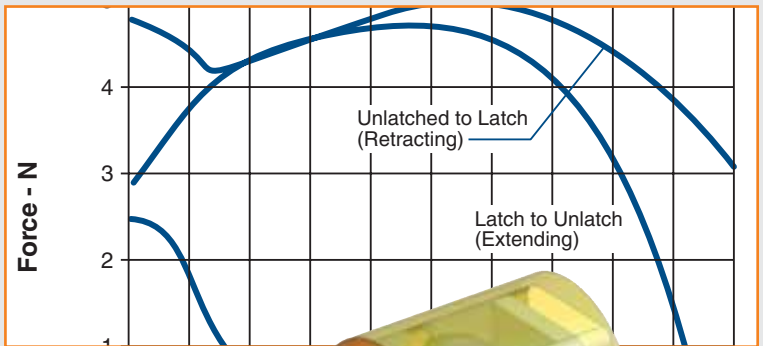

# New Ledex® Innovations Tailored to Your Requirements

Ledex® Products has been known for decades as a leader in solenoid innovation, problem solving and product development. This Innovation chapter of our catalogue describes new product platforms that we are developing for emerging market needs.

Below and on the following pages is a look at three different solenoid product technologies that we have recently developed.

Our goal is to make our customers increasingly competitive in a global market that is more and more demanding of new technologies and rapid advancements.

We look forward to putting any of these concepts to work in your application. Please give us a call to discuss your requirements.

	MagShift	PMA	CamBolt
	Page A3	Page A4-5	Page A6
Quiet Actuation	■		
Long Stroke		■	
Magnetic Latching		■	
Mechanical Latching			■
Shock Resistance			■
Bi-directional actuation		■	■
Potential for Very Low Cost	■		■
Medium to High Force	■	■	



## MagShift® Solenoids

- Very low noise – sub 40 dBA power ON noise, including end-of-stroke stop
- Highly flexible, can change profiles and stroke with only a plunger adjustment
- Stops in mid-air, no end-stop required



## PMA™

- Magnetic latching, both extend and retract possible
- Long stroke
- Bi-directional latching options are easily tailored to user needs
- Non-magnetic external components – enables significant packaging flexibility for your application
- Separate high volume and low volume design constructions developed
- Cost drivers reduced to magnet stack and windings
- No screw machine or metallic components required
- Flexible design since case is not in flux path



## CamBolt™

- Bi-directional locking solenoid
- Highly resistant to shock and vibration
- Mechanically locks at each end of stroke with no power required
- 2 position linear device
- Can be battery powered
- Small size, short stroke

# MagShift® Quiet Solenoids

MagShift® solenoids have several unique characteristics which differentiate this product from other linear open frame and tubular solenoids:

**Extremely low noise potential.** In a power ON mode, this unit will measure below 40 dBA, including the end-of-travel stop. This is accomplished by the elimination of the hard stop within the solenoid. Instead, the MagShift unit stops magnetically within the body of the solenoid.

**No impact forces.** As the unit reaches its power ON, end-of-travel position, there is no impact force from the unit. This eliminates potential issues of vibration or product life failures caused by the end-of-travel impact associated with some linear solenoids.

**Mechanical over-travel.** In a typical linear solenoid, once the power ON position is reached, no further travel of the plunger is possible. With the MagShift, the plunger is able to continue to travel past the electrical ON position when actuated externally by the application.

**Higher initial starting forces.** Due to the starting position of the plunger, the MagShift solenoid will, in general, have a higher starting force than some linear solenoids. This provides more starting force for a given power level solenoid.

**No residual magnetism.** Due to the elimination of internal components, the MagShift solenoid has no residual magnetism.

**Flexibility.** Due to the unique construction of this unit, the same assembly can be configured as either a push or a pull solenoid, allowing for greater flexibility in system design.

Although the MagShift performance curves will show the solenoid force ramp towards zero in the full power ON position, this unit will still hold a load when in the fully energised position. Due to the hysteresis characteristics of this unit, system return springs and light system loads can be held in the fully energised position, even though the unit will come to a magnetically zero position. This unit is ideally suited for system applications where high holding loads are not required, but where higher starting loads, quiet operation, or no impact vibrations are desired.

Note that the data shown below reflects only one design of this very flexible solenoid family. Please call to discuss your application.

## Specifications

Continuous Duty Cycle	100% at 20°C ambient temperature
Intermittent Duty Cycle	See below
Coil Insulation	Class "A": 105°C max. temperature standard. Other temperature classes are available
Coil Termination	Lead wires (other coil terminations available)

## Typical Net Force @ 20°C

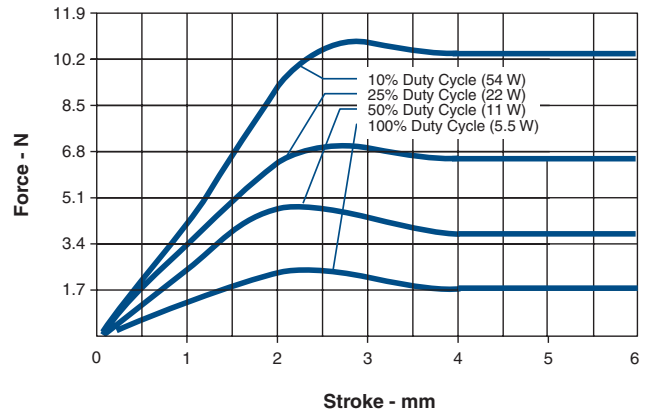

## Performance

Maximum Duty Cycle	100%	50%	25%	10%
Maximum ON Time (sec) when pulsed continuously	∞	80	22	8
Maximum ON Time (sec) for single pulse	∞	320	132	48
Watts (@ 20°C)	5.4	10.8	21.6	54
Ampere Turns (@ 20°C)	761	1076	1523	2408

Coil Data						
	Resistance (@20°C)	# Turns	Unlatched VDC	VDC (Nom)	VDC (Nom)	VDC (Nom)
awg			VDC			
29.5	24.97	1650	11.6	16.4	23.2	36.7
30.5	37.90	2004	14.3	20.2	28.6	45.2

## Dimensions mm

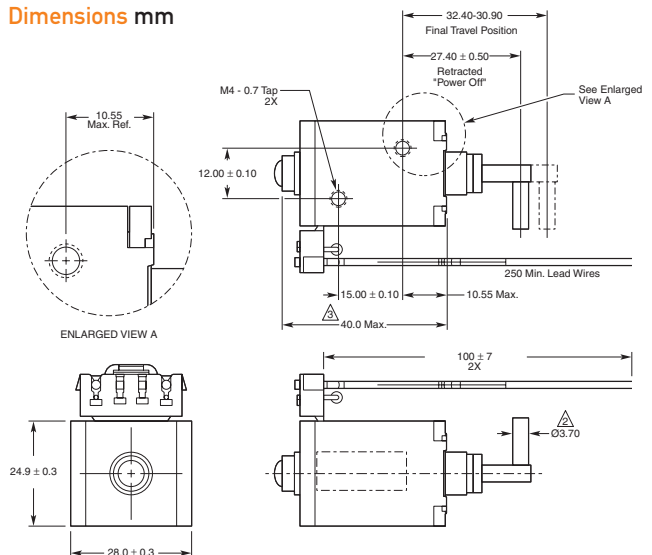

All specifications subject to change without notice.

# PMA™ Bi-Directional Locking Solenoids

- Long stroke latching applications – much longer than traditional linear solenoids
- Permanent magnetic latching design for lock and position control applications – both extend and retract possible
- 2 position, off/on solenoid – no return spring needed
- Flexible design – case is not in flux path; case can be plastic or metal to suit your application
- Higher starting force at long stroke and low power

All catalogue products manufactured after April 1, 2006 are RoHS Compliant



Ledex® introduces a new solenoid concept in their PMA family of magnetic latching linear actuators. These unique solenoids utilise permanent magnet technology to produce on/off linear force without the need for any magnetic steel components.

Incorporating a permanent magnet allows the unit to be driven in two directions. The force-stroke curve is relatively flat over the entire length, and is suitable for low power operations.

The addition of a steel washer will cause the magnets to latch at either or both ends of the stroke. Long strokes greater than 25 mm can be achieved with more significant starting forces than traditional DC solenoids.

Other than these steel washers, no metallic components are required which can greatly reduce the mass of the actuator. The units shown in the photo have a metal output shaft and case, but can also be made with plastic. The mass will then be dramatically reduced to primarily the copper coil and magnets.

In direct correlation to the mass, eliminating the need for metallic components allows for significant cost reduction as well. While copper and magnets are still present, the remaining plastic parts will be minimal.

## How the PMA Concept works

- PMA solenoid design consists of a coil assembly and an output shaft assembly
- Dual coil, opposite polarity, common wind
- Permanent magnet actuates within field
- Remaining components non-magnetic, only serve for structure and stops

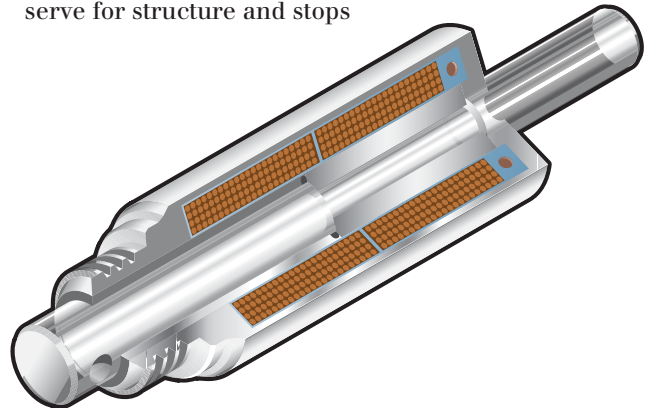

All specifications subject to change without notice.

# PMA™ Bi-Directional Locking Solenoids

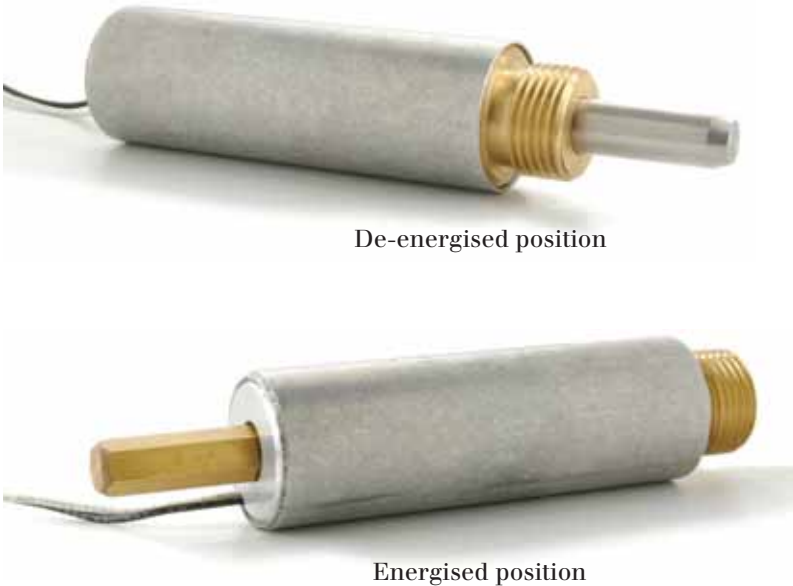

**Bi-directional latching performance**  
is relatively flat over entire stroke in both directions.

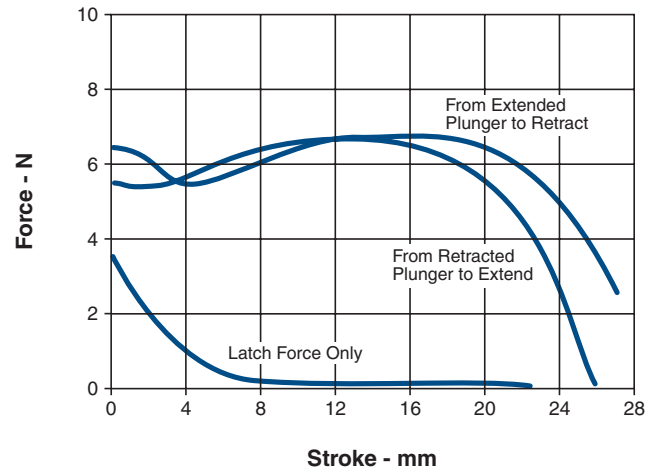

**Unidirectional latching performance**

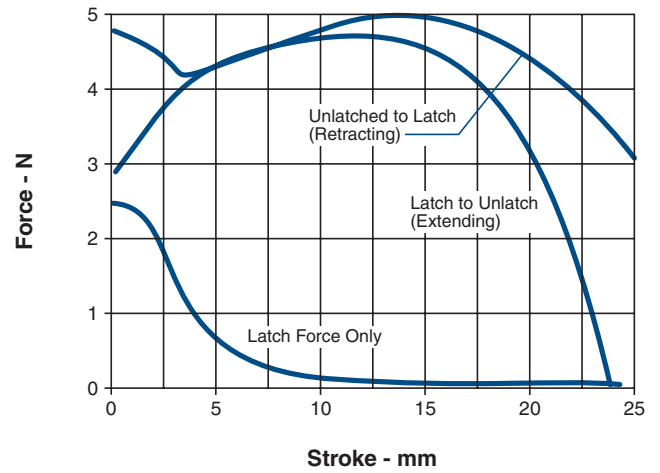

**Dimensions mm**

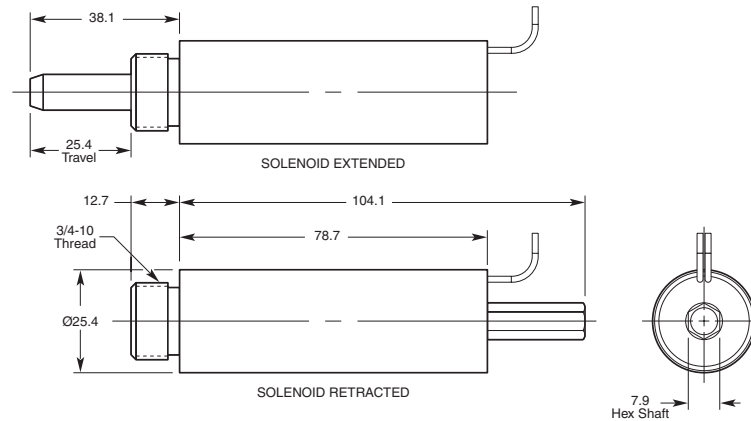

All specifications subject to change without notice.

# CamBolt™ Bi-Directional Locking Actuator

All catalogue products manufactured after April 1, 2006 are RoHS Compliant

- Two position, bi-directional locking device
- Resistant to vibration, due to rotational driver mechanism, plus potential pole piece attraction
- Small size
- Low power levels

CamBolt is a bi-directional locking device resistant to shock, vibration, and high manual loads in a power-off state. The CamBolt design uses the rotary motion of a permanent magnet to translate into linear actuation travel.

The cam assembly, driven by the magnet's rotation, provides a mechanical lock, preventing any linear movement once end-of-travel is reached. By utilizing the residual magnetism of the magnet within the assembly, the unit will resist any possible shock or vibration forces which may induce rotational movement of the cam. This creates a locking force which is limited only by the shear strength of the housing materials used.

CamBolt is ideal for low power operations. Extremely short duty cycles and low voltage requirements make battery operation possible. With the usage of a permanent magnet, only 1 metallic component is required, greatly reducing product mass.

CamBolt does not have a significant force versus stroke profile, therefore, it should be used primarily for uni-directional or bi-directional locking, and not as prime mover.

## How it Works

- Rotary actuated magnet drives linear motion actuator through cam geometry
- Rotary magnet driven by coil and small pole piece
- Unit locks in a linear direction via cam geometry (non-reversible angle)

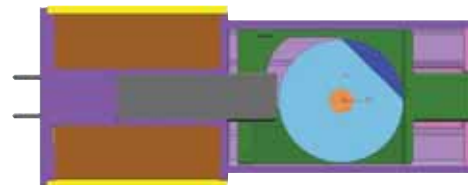
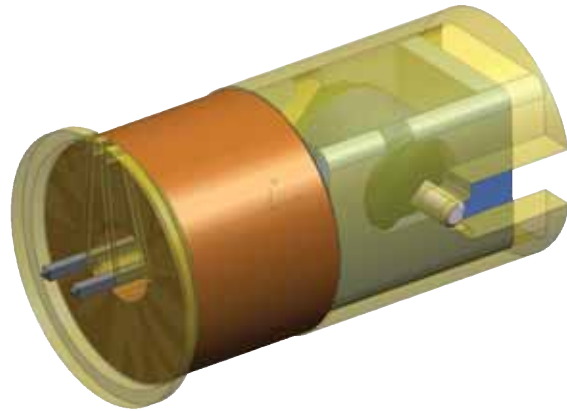

Unlocked (retracted)

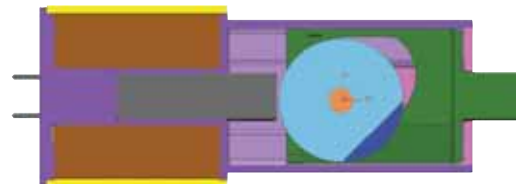

Locked (extended)

This is a concept overview – please call us to discuss your application.

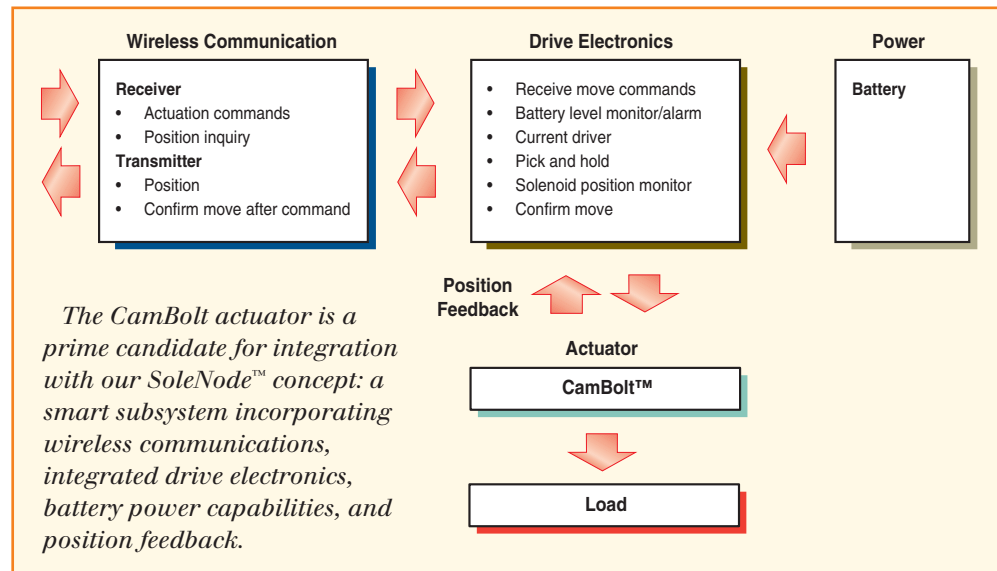

All specifications subject to change without notice.

## Ultimag<sup>®</sup> Rotary Actuators



**WARNING:** Exposed Magnet may affect pacemakers. In the event a product unit's magnet is exposed due to product disassembly, Pacemaker Wearers should distance themselves 3 metres from exposed magnet.

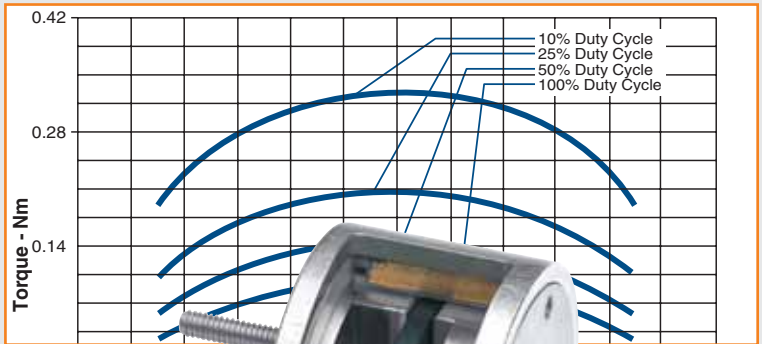

# Ultimag® Rotary Actuators



- Speeds over 100 Hz
- Peak torque of over 1.5 Nm
- 100 million actuation life
- Three standard sizes



All catalogue products manufactured after April 1, 2006 are RoHS Compliant

## Ultimag® Principle of Operation

Ultimag® operates on the simple principle of attraction and repulsion of opposite and like magnetic poles. The permanent magnetic armature has twice as many poles as the stator. In the de-energised state, the armature poles each share half a stator pole, causing the shaft to seek mid-stroke. When power is applied, the

stator poles are polarised. This attracts half and repels the other half of the armature poles, causing the shaft to rotate. When the voltage is reversed, the stator poles are polarised with the opposite pole. Consequently, the opposite poles of the armature are attracted and repelled, thus causing rotation in the opposite direction.

The Ultimag Series has been developed in response to application needs for higher speed and higher torque motion control components. We have found that many applications require a working stroke less than 360°, yet still employ motors with their associated complex and expensive controls and linkages. As a result, a powerful, extremely fast short stroke actuator has many design advantages for industrial, office automation, automotive and medical applications.

We have been designing and manufacturing world class, innovative motion control components for over 60 years. Our patented Ultimag series is the latest of our state-of-the-art developments in rotary actuation products.

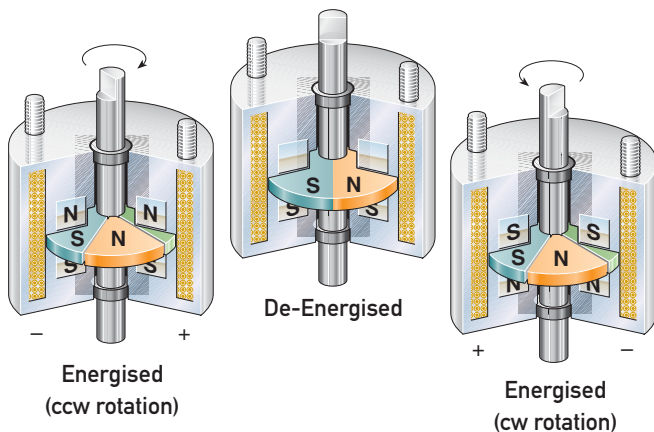

# Ultimag<sup>®</sup> Rotary Actuators

## The Ultimag<sup>®</sup> Difference

Ultimag<sup>®</sup> offers a bidirectional, centre return function not found in rotary solenoids. The Ultimag is substantially faster than other solenoids, and can be operated in an on/off mode or proportionally, in both open loop and closed loop systems.

The Ultimag does not offer 360° of rotation which is definitive of motors. With this stroke limitation in mind, Ultimag provides an inexpensive alternative for limited stroke applications, particularly, when total cost of system control is included.

Ultimag actuators offer a 45° stroke. However, the design is capable of a maximum stroke of 160°. Gears, belts, pulley, etc., can be employed to amplify stroke. In all cases, an increase in stroke will cause a reduction in torque.

For shorter strokes, electronic or mechanical stops can be used. By having a unit tooled to perform a specific stroke less than 45°, more torque will be obtained.

When adding the Ultimag to your application, the shaft must be supported to avoid stress fractures to the magnet.

## Temperature Limitation

The permanent magnet in the Ultimag is NdFeB. For applications running above 130°C, we do not recommend the Ultimag, since the NdFeB magnets irreversibly degrade after reaching a 150°C temperature.

## Typical Examples of Custom Features

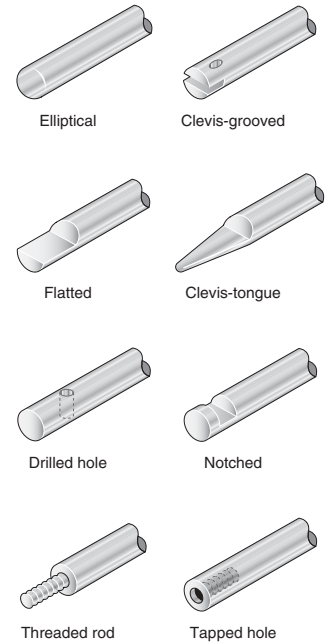

ROTARY Ultimag<sup>®</sup>

## Ultimag Selection Overview

Size	Package Dimensions (mm)		Net Starting Torque (Nm) @ Specified Duty Cycle*				Net Ending Torque (Nm) @ Specified Duty Cycle*			
	Dia.	Length	100%	50%	25%	10%	100%	50%	25%	10%
4EM	41	26	0.10	0.14	0.20	0.33	0.02	0.06	0.10	0.19
5EM	49	33	0.23	0.33	0.44	0.71	0.04	0.11	0.23	0.44
6EM	59	41	0.57	0.68	1.13	1.58	0.28	0.43	0.57	0.83

\*Note: Torque outputs degrade with elevated temperatures.

## How to Use Ultimag Performance Charts

- Select one of the four columns which provides the appropriate duty cycle. (For example 50%.)
- Reading down this column provides a variety of performance and electrical data including maximum on time, watts, and amp turns.
- Following down the column further into the VDC ratings, select the voltage which most closely matches your supply voltage. (For example, 11.5 for a 12 VDC power supply.)
- Read across (to the left) to select the awg suffix to complete the part number when ordering. (In this example using our 5EM chart, 25 awg is required, thus to order, specify: 199173-025.)

## Performance

Maximum Duty Cycle*	100%	50%	25%	10%
$K_M$ (mNm/ $\sqrt{\text{watt}}$ )	76.3	84.6	57.4	48.3
Maximum ON Time (sec) when pulsed continuously <sup>1</sup>	∞	40	15	4
Maximum ON Time (sec) for single pulse <sup>2</sup>	∞	109	36	10
Typical Energise Time (msec) <sup>3</sup>	6.0	5.5	4.5	4.0
Watts (@ 20°C)	2.1	42	84	210
Ampere Turns (@ 20°C)	621	878	1242	1964

## Coil Data

avg (0XX) <sup>4</sup>	Resistance (@20°C)	# Turns <sup>5</sup>	VDC (Nom)	VDC (Nom)	VDC (Nom)	VDC (Nom)
23	1.05	128	4.7	6.6	9.4	14.8
24	2.24	213	6.9	9.7	13.7	21.7
25	3.16	240	8.1	11.5	16.3	25.8
26	4.45	270	9.7	13.7	19.3	30.6
27	8.50	404	13.4	18.9	26.7	42.2
28	11.90	452	15.8	22.3	31.6	50.0
29	21.10	630	21.0	29.7	42.1	67.0
30	29.50	705	24.9	35.2	49.8	78.7
31	50.30	948	32.5	45.9	65.0	103.0
32	82.70	1232	41.7	58.9	83.0	132.0
33	134.00	1576	53.0	74.9	106.0	168.0

# Ultimag® Size 4EM

Part Number: 199172-0XX

All catalogue products manufactured after April 1, 2006 are RoHS Compliant

## Specifications

Dielectric Strength	1000 VRMS (23 awg); 1200 VRMS (24-33 awg)
Recommended Minimum Heat Sink	Maximum watts dissipated by the Ultimag are based on an unrestricted flow of air at 20°C, with the Ultimag mounted on the equivalent of an aluminium plate measuring 15.9 cm square x 0.32 cm thick
Thermal Resistance	7.6°C/watt with heatsink; 15.0°C/watt without heatsink
Rotor Inertia	8.43 x 10 <sup>-7</sup> (kgm <sup>2</sup> )
Peak Torque Rating (Tp)	0.32 Nm
Power Input	145 watts (stalled at Tp; 25°C; Pp)
Number of Phases	1
Static Friction (Tf)	7 mNm
-3dB Closed Loop	78 Hz
Maximum Winding	180°C
Number of Poles	6
Dimensions:	Ø41.66 mm x 26.3 mm L (See page B10)



## Performance

Maximum Duty Cycle	100%	50%	25%	10%
K <sub>M</sub> (mNm/√watt)	40.6	35.7	32.2	30.1
Maximum ON Time (sec) when pulsed continuously <sup>1</sup>	∞	40	15	4
Maximum ON Time (sec) for single pulse <sup>2</sup>	∞	108	34	9
Typical Energise Time (msec) <sup>3</sup>	6	5	4.5	3.5
Watts (@ 20°C)	14.5	29	58	145
Ampere Turns (@ 20°C)	510	721	1020	1613

### Coil Data

awg (0XX) <sup>4</sup>	Resistance (@20°C)	# Turns <sup>5</sup>	VDC (Nom)	VDC (Nom)	VDC (Nom)	VDC (Nom)
23	0.71	104	3.2	4.5	6.4	10.1
24	1.54	174	4.7	6.7	9.4	14.9
25	2.15	195	5.6	7.9	11.2	17.6
26	3.01	219	6.6	9.3	13.2	20.9
27	5.78	328	9.2	12.9	18.3	28.9
28	8.09	368	10.8	15.3	21.7	34.3
29	14.40	515	14.5	20.4	28.9	45.7
30	20.11	575	18.9	24.2	37.7	59.6
31	34.40	774	22.3	31.6	44.6	71.0
32	56.60	1008	28.7	40.5	57.0	91.0
33	91.40	1288	36.0	51.5	73.0	115.0

## How to Order

Add the coil awg number (0XX) to the part number (for example: to order a 25% duty cycle rated at 18.3 VDC, specify 199172-027).

Please see [www.ledex.com](http://www.ledex.com) (click on Stock Products tab) for our list of stock products available through our distributors.

- <sup>1</sup> Continuously pulsed at stated watts and duty cycle
- <sup>2</sup> Single pulse at stated watts (with coil at ambient room temperature 20°C)
- <sup>3</sup> Typical energise time based on no load condition. Times shown are for half of full rotary stroke starting at centre-off position.
- <sup>4</sup> Other coil awg sizes available — please consult factory
- <sup>5</sup> Reference number of turns

**WARNING:** Exposed Magnet may affect pacemakers. In the event a product unit's magnet is exposed due to product disassembly, Pacemaker Wearers should distance themselves 3 metres from exposed magnet.

All specifications subject to change without notice.

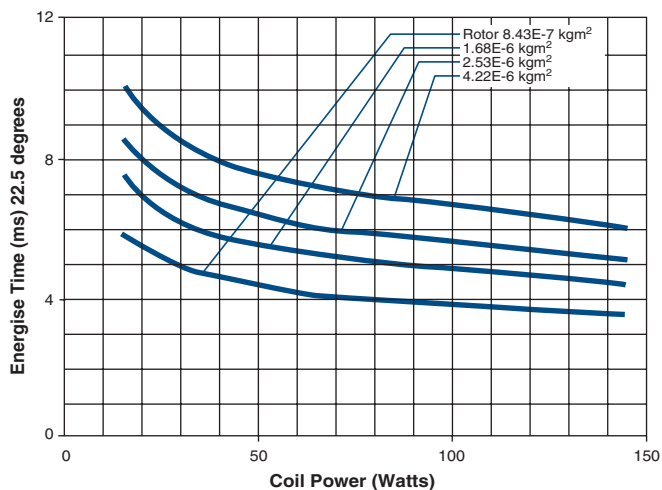
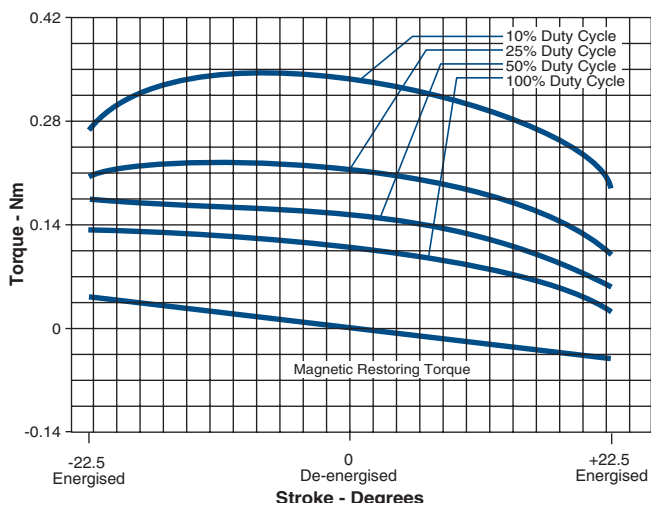
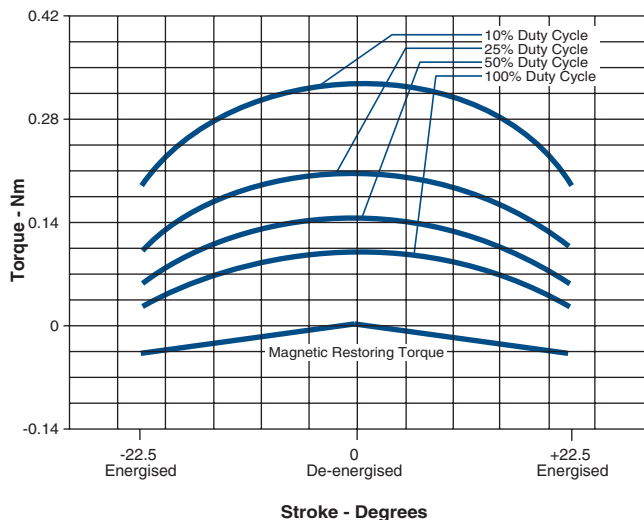

Torque values for reference only.

All specifications subject to change without notice.

# Ultimag® Size 5EM

Part Number: 199173-0XX

All catalogue products manufactured after April 1, 2006 are RoHS Compliant

## Specifications

Dielectric Strength	1000 VRMS (23 awg); 1200 VRMS (24-33 awg)
Recommended Minimum Heat Sink	Maximum watts dissipated by the Ultimag are based on an unrestricted flow of air at 20°C, with the Ultimag mounted on the equivalent of an aluminium plate measuring 19.1 cm square x 0.32 cm thick
Thermal Resistance	5.36°C/watt with heatsink; 12.9°C/watt without heatsink
Rotor Inertia	3.085 x 10 <sup>-6</sup> (kgm <sup>2</sup> )
Peak Torque Rating (Tp)	0.7 Nm
Power Input	210 watts (stalled at Tp; 25°C; Pp)
Number of Phases	1
Static Friction (Tf)	7 mNm
-3dB Closed Loop	66.5 Hz
Maximum Winding	180°C
Number of Poles	6
Dimensions:	Ø49.2 mm x 31.75 mm L max (See page B10)



## Performance

Maximum Duty Cycle*	100%	50%	25%	10%
K <sub>m</sub> (mNm/√watt)	76.3	84.6	57.4	48.3
Maximum ON Time (sec) when pulsed continuously <sup>1</sup>	∞	40	15	4
Maximum ON Time (sec) for single pulse <sup>2</sup>	∞	109	36	10
Typical Energise Time (msec) <sup>3</sup>	6.0	5.5	4.5	4.0
Watts (@ 20°C)	2.1	42	84	210
Ampere Turns (@ 20°C)	621	878	1242	1964

### Coil Data

awg (0XX) <sup>4</sup>	Resistance (@20°C)	# Turns <sup>5</sup>	VDC (Nom)	VDC (Nom)	VDC (Nom)	VDC (Nom)
23	1.05	128	4.7	6.6	9.4	14.8
24	2.24	213	6.9	9.7	13.7	21.7
25	3.16	240	8.1	11.5	16.3	25.8
26	4.45	270	9.7	13.7	19.3	30.6
27	8.50	404	13.4	18.9	26.7	42.2
28	11.90	452	15.8	22.3	31.6	50.0
29	21.10	630	21.0	29.7	42.1	67.0
30	29.50	705	24.9	35.2	49.8	78.7
31	50.30	948	32.5	45.9	65.0	103.0
32	82.70	1232	41.7	58.9	83.0	132.0
33	134.00	1576	53.0	74.9	106.0	168.0

\*Not recommended for full stroke at 100% duty cycle.

## How to Order

Add the coil awg number (0XX) to the part number (for example: to order a 25% duty cycle rated at 26.7 VDC, specify 199173-027).

Please see [www.ledex.com](http://www.ledex.com) (click on Stock Products tab) for our list of stock products available through our distributors.

- <sup>1</sup> Continuously pulsed at stated watts and duty cycle
- <sup>2</sup> Single pulse at stated watts (with coil at ambient room temperature 20°C)
- <sup>3</sup> Typical energise time based on no load condition. Times shown are for half of full rotary stroke starting at centre-off position.
- <sup>4</sup> Other coil awg sizes available — please consult factory
- <sup>5</sup> Reference number of turns

**WARNING:** Exposed Magnet may affect pacemakers. In the event a product unit's magnet is exposed due to product disassembly, Pacemaker Wearers should distance themselves 3 metres from exposed magnet.

All specifications subject to change without notice.

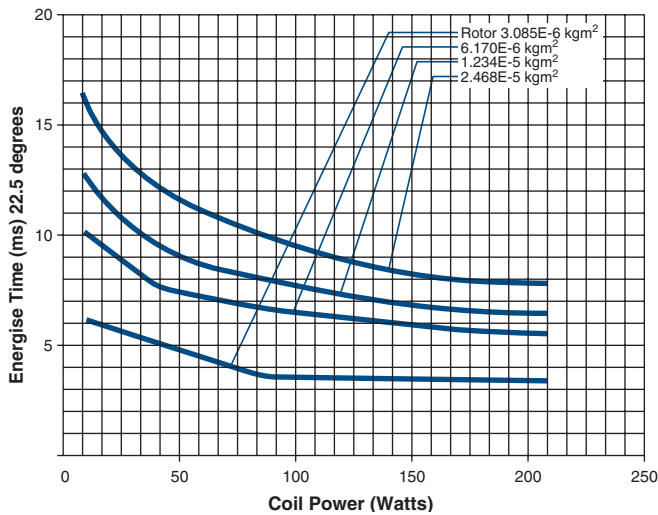
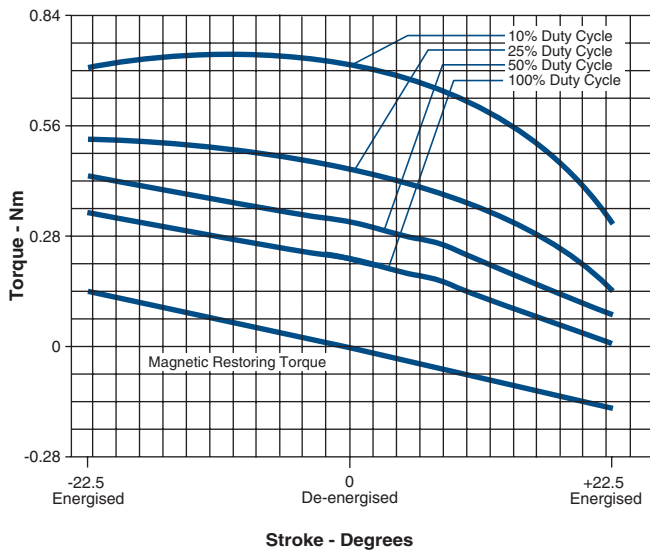
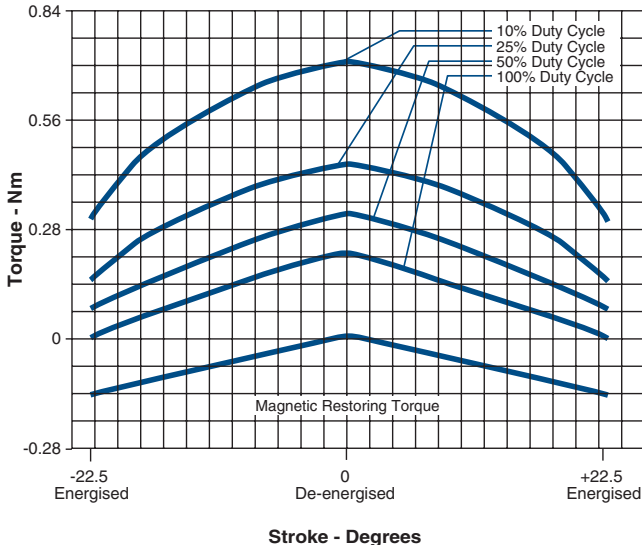

Graph 1 shows three position operation. In any mode, the armature seeks centre of stroke at zero power. Applying a positive or negative voltage causes the shaft to rotate clockwise or counter clockwise. When power is removed, the restoring torque is applied to the load, or alternatively, the shaft can be driven to centre under power.

Graph 2 shows operation end-to-end. Note the high starting torque for high starting acceleration or for stopping the load by means of reverse voltage at the end of the stroke. If the device is used in a full stroke application, the load can be externally latched, detented, or biased to either end of stroke.

**NOTE:** The Size 5EM Ultimag is not recommended for full stroke operation at 100% duty cycle.

Graph 3 shows how speed varies with load. Each curve represents a different inertial load, which is a multiple of the armature inertia.

Calculate the inertia of your system, then use this chart to determine Ultimag speed in your application. Inertia determination of simple shapes is shown in most engineering handbooks; complex shapes are calculated in solid modeling software or are measured empirically. This graph represents half of the full rotary stroke starting at the centre-off position.

# Ultimag® Size 6EM

Part Number: 199174-0XX

All catalogue products manufactured after April 1, 2006 are RoHS Compliant

## Specifications

Dielectric Strength	1000 VRMS (23 awg); 1200 VRMS (24-33 awg)
Recommended Minimum Heat Sink	Maximum watts dissipated by the Ultimag are based on an unrestricted flow of air at 20°C, with the Ultimag mounted on the equivalent of an aluminium plate measuring 31.43 cm square x 0.32 cm thick
Thermal Resistance	3.58°C/watt with heatsink; 8.52°C/watt without heatsink
Rotor Inertia	5.676 x 10 <sup>-6</sup> (kgm <sup>2</sup> )
Peak Torque Rating (Tp)	1.6 Nm
Power Input	320 watts (stalled at Tp; 25°C; Pp)
Number of Phases	1
Static Friction (Tf)	7 mNm
-3dB Closed Loop	12.8 Hz
Maximum Winding	180°C
Number of Poles	6
Dimensions:	Ø58.72 mm x 40.6 mm L (See page B10)



## Performance

Maximum Duty Cycle	100%	50%	25%	10%
Maximum ON Time (sec) when pulsed continuously <sup>1</sup>	∞	40	15	5
Maximum ON Time (sec) for single pulse <sup>2</sup>	∞	143	47	11
Typical Energise Time (msec) <sup>3</sup>	17	12	10.5	8.5
Watts (@ 20°C)	32	64	128	320
Ampere Turns (@ 20°C)	980	1386	1960	3100

Coil Data						
awg (0XX) <sup>4</sup>	Resistance (@20°C)	# Turns <sup>5</sup>	VDC (Nom)	VDC (Nom)	VDC (Nom)	VDC (Nom)
23	2.65	267	9.2	13.0	18.4	29.1
24	5.02	396	12.7	17.9	25.4	40.1
25	7.03	444	15.0	21.2	30.0	47.4
26	12.60	625	20.1	28.4	40.2	63.5
27	17.60	700	23.8	33.6	47.5	75.1
28	29.90	936	30.9	43.7	61.9	97.8
29	49.50	1225	39.8	56.3	80.0	126.0
30	79.70	1560	51.0	71.4	101.0	160.0
31	126.50	1962	64.0	90.0	127.0	201.0
32	198.30	2440	80.0	112.6	159.0	252.0
33	306.20	2992	99.0	140.0	198.0	313.0

## How to Order

Add the coil awg number (0XX) to the part number (for example: to order a 25% duty cycle rated at 25.4 VDC, specify 199174-024).

Please see [www.ledex.com](http://www.ledex.com) (click on Stock Products tab) for our list of stock products available through our distributors.

- <sup>1</sup> Continuously pulsed at stated watts and duty cycle
- <sup>2</sup> Single pulse at stated watts (with coil at ambient room temperature 20°C)
- <sup>3</sup> Typical energise time based on no load condition. Times shown are for half of full rotary stroke starting at centre-off position.
- <sup>4</sup> Other coil awg sizes available — please consult factory
- <sup>5</sup> Reference number of turns

**WARNING:** Exposed Magnet may affect pacemakers. In the event a product unit's magnet is exposed due to product disassembly, Pacemaker Wearers should distance themselves 3 metres from exposed magnet.

All specifications subject to change without notice.

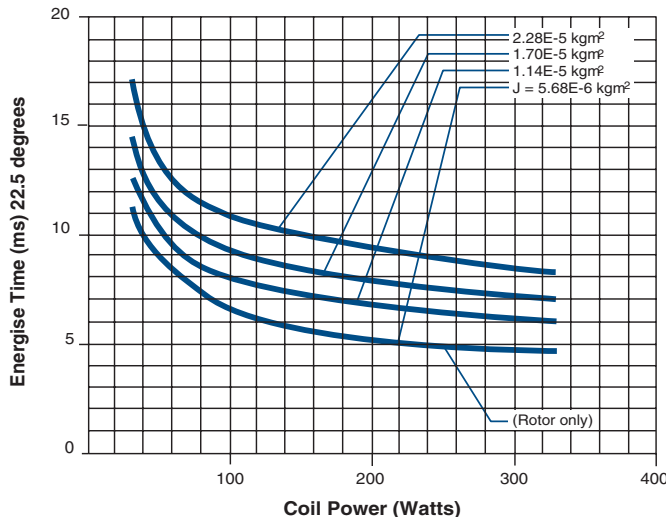
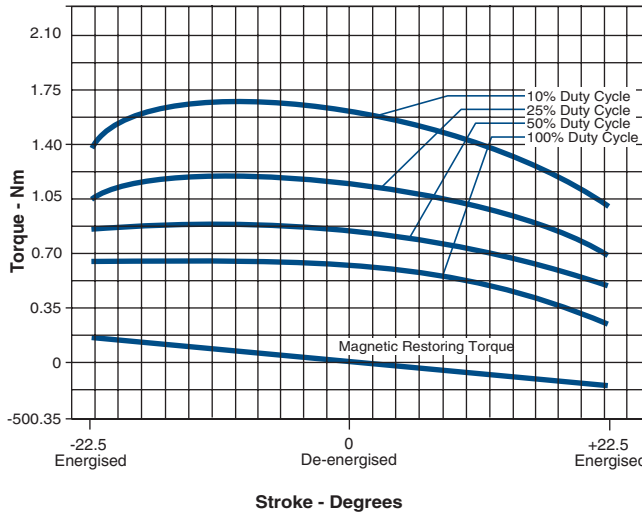
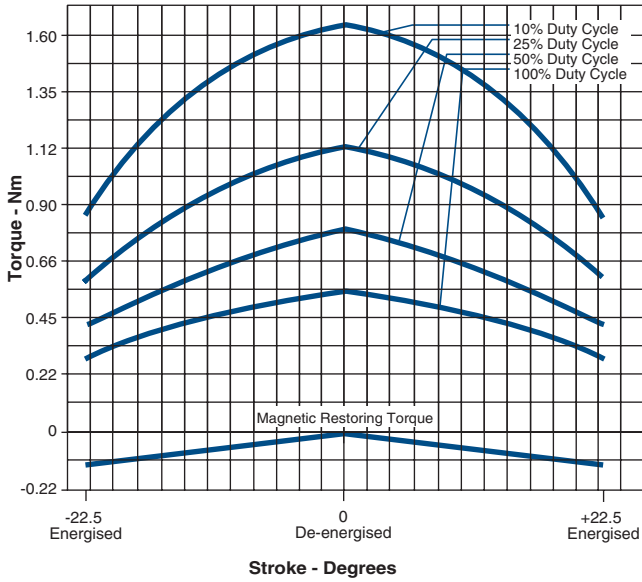

Graph 1 shows three position operation. In any mode, the armature seeks centre of stroke at zero power. Applying a positive or negative voltage causes the shaft to rotate clockwise or counter clockwise. When power is removed, the restoring torque is applied to the load, or alternatively, the shaft can be driven to centre under power.

Graph 2 shows operation end-to-end. Note the high starting torque for high starting acceleration or for stopping the load by means of reverse voltage at the end of the stroke. If the device is used in a full stroke application, the load can be externally latched, detented, or biased to either end of stroke.

Graph 3 shows how speed varies with load. Each curve represents a different inertial load, which is a multiple of the armature inertia.

Calculate the inertia of your system, then use this chart to determine Ultimag speed in your application. Inertia determination of simple shapes is shown in most engineering handbooks; complex shapes are calculated in solid modeling software or are measured empirically. This graph represents half of the full rotary stroke starting at the centre-off position.

# Ultimag® Dimensions

ROTARY Ultimag®

mm

4EM

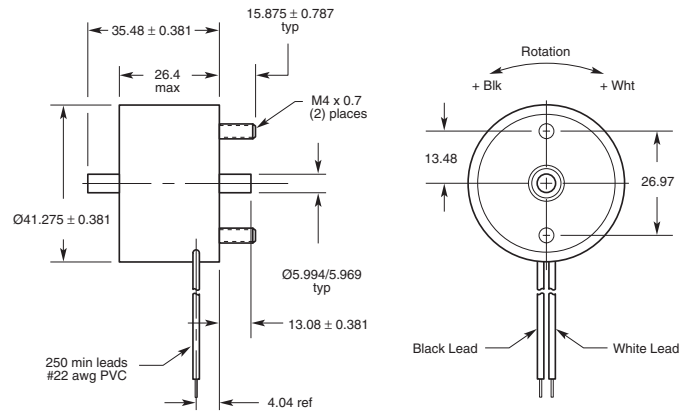

5EM

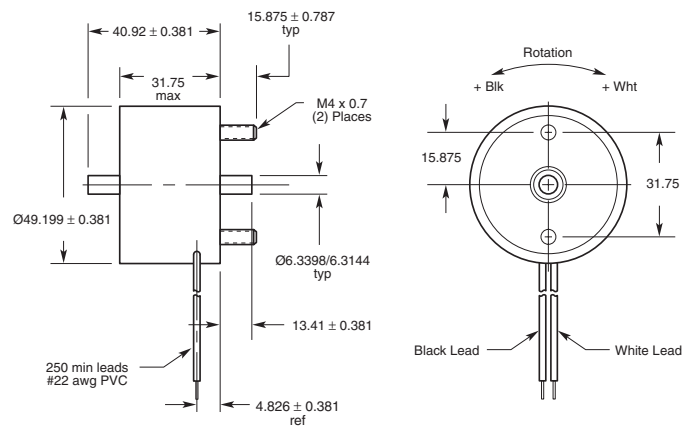

6EM

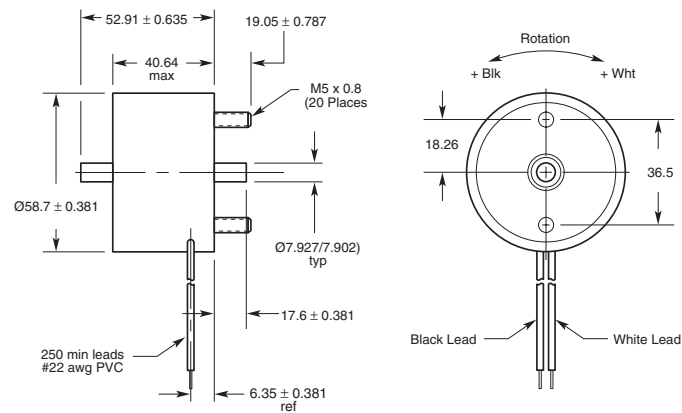

All specifications subject to change without notice.

## BTA<sup>®</sup> Rotary Actuators

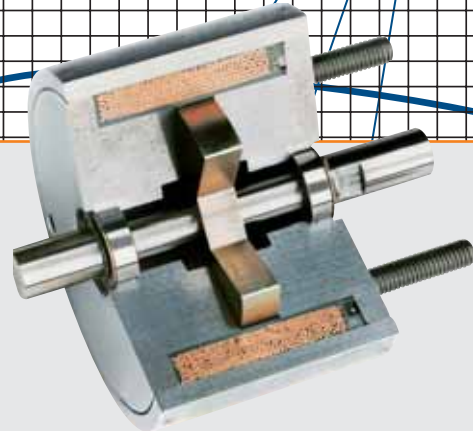
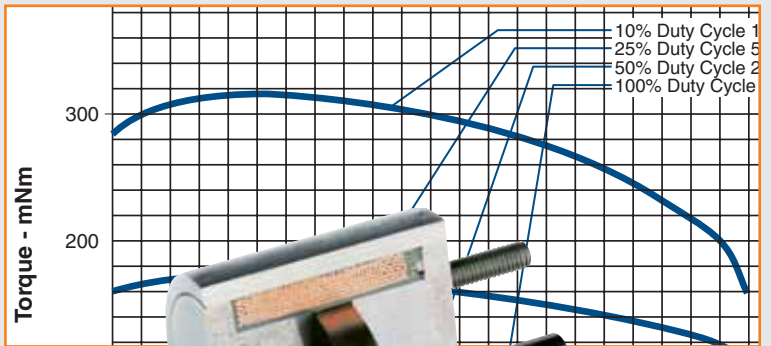

# BTA® Brushless Torque Actuators

ROTARY BTA®



- Controllable velocity and position
- Quiet, shock-free operation
- 100+ million cycle life
- No axial stroke
- Adaptable to closed loop operation
- Completely enclosed construction
- Excellent unit-to-unit performance consistency
- Low power consumption

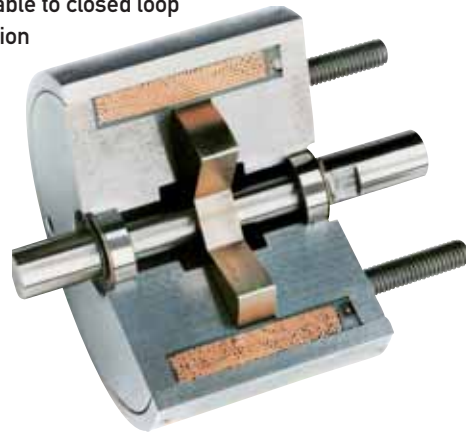

All catalogue products manufactured after April 1, 2006 are RoHS Compliant

## BTA Principle of Operation

The BTA has a single phase coil with three stator poles and matching rotor poles. When the coil is energised, the poles align along the flux path. With the three pole design, it is possible to have a stroke of up to 45°. In practical usage, external stops should be used to attain maximum unit life. Subsequently, the stroke angle is slightly shorter. Use of such mechanical

stops also serve to limit the actuator stroke to its optimum stroke/torque capacity. By not requiring full stroke actuation, the BTA offers maximum design flexibility across a wide range of stroke angles and torque requirements.

BTA rotary, non-axial stroke actuators are a good solution for applications requiring reliable, low hysteresis operation with a good torque profile as

required for proportional operation.

Using simple pulse width modulation (PWM) to control coil current, the BTA allows open or closed loop velocity and position control. Such proportional control is ideal for silent, shock-free actuation applications. (In open loop applications, PWM improves hysteresis over variable DC voltage control.)

The addition of position feedback, and the subsequent improved system stiffness and accuracy, enables the BTA to be used in closed loop applications.

The bearing system consists of two ball-type bearings which are key to low hysteresis operation.

## Quiet

The BTA can operate virtually noise free. Electronically controlled, the BTA provides soft, shock-free cycling without the noise associated with end-of-stroke mechanical stops.

For machines such as the mail sorter pictured at right, which utilises hundreds of these actuators, the BTA is used in conjunction with cushioned external stops to minimise noise and extend the unit's life to that of the precision ball bearings.

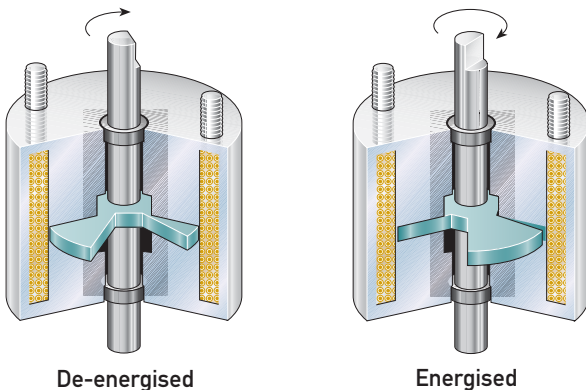

# BTA<sup>®</sup> Brushless Torque Actuators

## Rapid Cycling

The BTA actuator requires only milliseconds to rotate through its entire stroke. It can maintain this extremely fast operating speed repetitively without diminishing accuracy or repeatability, or reducing the overall life of the unit.

## Rugged

The BTA design eliminates the axial travel associated with conventional rotary actuators. In so doing, the BTA eliminates loading on associated mechanical linkages, and reduces the number of moving parts and the wear they receive. The BTA is self-contained in an industry standard size which enables easy mounting and interchangeability. The unit is permanently lubricated and requires no adjustment or maintenance over its entire life.

## Powerful . . . with Less Power

The BTA actuator offers considerably more torque than comparable sized rotary actuator designs.

Even with its high torque output, the BTA requires 40% less power input than competitive units. On high volume applications such as this mail sorter, the BTA conserves as much as 18.9 watts per actuator cycle.

## Design Considerations

### Performance Curves

The torque curves on the following pages are typical data taken with a 20°C coil and have not been derated. Typical derating factors are 30% due to coil heating.

### Duty Cycle

Duty cycle is determined by: ON time/(ON + OFF time).

For example: an actuator operated for 30 seconds, then off for 90 seconds.  
 $30 \text{ sec ON} / (30 \text{ Sec ON} + 90 \text{ sec OFF}) = 30/120 = 1/4$  or 25% duty cycle

BTA actuators are rated for various duty cycles ranging from continuous to 10% duty.

### Life

When selecting a BTA actuator, as with any other style, it is important to consider the effects of heat on life. When used with a constant voltage supply, an increase in coil temperature reduces the work output and the life of the unit. Standard life is more than 100,000,000 cycles.

## Power Requirements

Voltage applied to the actuator must be matched to the coil wire size for proper operation. Actuators are catalogued in coil awgs ranging from #23 up to #35 to accommodate your input power. Refer to the individual model specification pages for coil wire awg recommendations. Many other coil awg sizes are available. Please feel free to contact our application engineering department for availability.

## Options and Modified Designs

Even though our standard BTAs are in stock, our customers often require a product with unique features or performance capabilities. In fact, almost 80% of all products that we make are either modified or custom built to meet our customers' exact application requirements.

So, if you don't find what you're looking for in the catalogue, give us a call to discuss your needs with one of our application engineers.

## Typical Examples of Custom Features

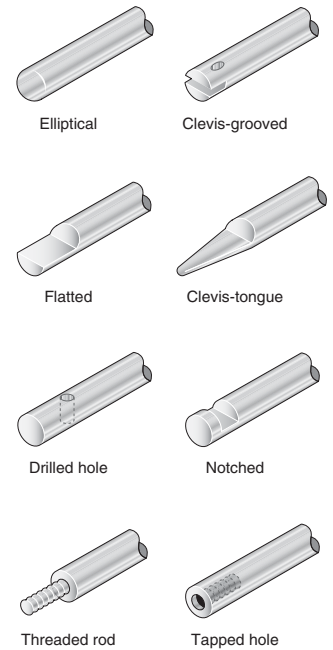

ROTARY BTA<sup>®</sup>

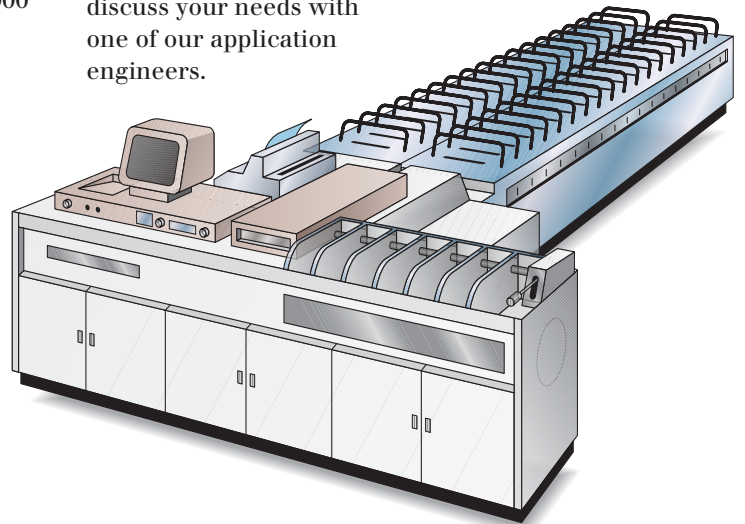

# BTA® Selection

Brushless Torque Actuators are available in five sizes. Use the selection overview chart to determine which size offers the desired performance and mechanical specifications. Refer to the individual size specification pages for complete performance and mechanical data.

## BTA Selection Overview

Size	Package Dimensions (mm)		Maximum Stroke (degrees)	Gross Starting Torque (mNm) @ Specified Duty Cycle				Gross Ending Torque (mNm) @ Specified Duty Cycle			
	Dia.	Length		100%	50%	25%	10%	100%	50%	25%	10%
	2EVM ●	30.2	18.3	45	N/A*	31.6	56.5	113.0	N/A*	21.5	37.3
3EVM	34.9	22.6	45	31.6	50.9	94.9	187.6	24.9	35.0	59.5	99.4
4EVM	41.3	26.8	45	45.2	104.0	180.8	322.1	40.7	72.3	113.0	180.8
5EVM	49.2	32.1	45	153.7	266.7	420.4	678.0	117.5	185.3	293.8	474.6
6EVM	58.7	41.3	45	384.2	655.4	971.8	1457.7	226.0	418.1	565.0	791.0

All data is at 20°C coil temperature. Torque outputs degrade with elevated temperatures.

\* Not recommended for 100% duty.

● Well-suited for battery operation.



See the "Battery Operated Solenoids" section for complete information.

## How to Use BTA Performance Charts

- Select one of the four columns which provides the appropriate duty cycle. (For example 50%.)
- Reading down this column provides a variety of performance and electrical data including maximum on time, watts, and amp turns.
- Following down the column further into the VDC ratings, select the voltage which most closely matches your supply voltage. (For example, 7.6 for an 8 VDC power supply.)
- Read across (to the left) to select the awg suffix to complete the part number when ordering. (In this example using our 2EV chart, 28 awg is required, thus to order, specify: 195190-028.

## Performance

	100%	50%	25%	10%
Maximum Duty Cycle	∞	∞	∞	∞
Maximum ON Time (sec) when pulsed continuously	∞	100	36	7
Maximum ON Time (sec) for single pulse	∞	162	44	8
Typical Energise Time (msec)	20	15	11	8
Watts (@ 20°C)	10	20	40	100
Ampere Turns (@ 20°C)	331	469	663	1048

Coil Data						
awg (0XX) <sup>4</sup>	Resistance (@20°C)	# Turns <sup>5</sup>	VDC (Nom)	VDC (Nom)	VDC (Nom)	VDC (Nom)
24	0.47	72	2.2	3.1	4.3	6.9
25	0.67	82	2.6	3.7	5.2	8.2
26	0.94	92	3.1	4.3	6.1	9.7
27	1.33	104	3.6	5.2	7.3	11.5
28	2.86	174	5.4	7.6	10.7	16.9
29	4.01	195	6.3	9.0	12.7	20.0
30	7.69	292	8.8	12.4	17.5	27.7
31	10.80	328	10.4	14.7	20.8	32.9
32	19.26	460	13.9	19.6	27.8	43.9
33	26.96	515	16.4	23.2	32.8	52.0
34	45.82	690	21.4	30.3	42.8	68.0
35	63.76	768	25.3	35.7	50.0	80.0

# BTA<sup>®</sup> Size 2EVM

Part Numbers: Clockwise Rotation 195927-0XX  
Counter-Clockwise Rotation 195936-0XX

All catalogue products manufactured after April 1, 2006 are RoHS Compliant

## Performance

Maximum Duty Cycle*	50%	25%	10%		
Maximum ON Time (sec)	15	6	2		
when pulsed continuously <sup>1</sup>					
Maximum ON Time (sec)	44	15	4		
for single pulse <sup>2</sup>					
Typical Energise Time (msec) <sup>3</sup>	15	11	8		
Watts (@ 20°C)	20	40	100		
Ampere Turns (@ 20°C)	469	663	1048		
Coil Data					
awg (0XX) <sup>4</sup>	Resistance (@20°C)	# Turns <sup>5</sup>	VDC (Nom)	VDC (Nom)	VDC (Nom)
24	0.47	72	3.1	4.3	6.9
25	0.67	82	3.7	5.2	8.2
26	0.94	92	4.3	6.1	9.7
27	1.33	104	5.2	7.3	11.5
28	2.86	174	7.6	10.7	16.9
29	4.01	195	9.0	12.7	20.0
30	7.69	292	12.4	17.5	27.7
31	10.80	328	14.7	20.8	32.9
32	19.26	460	19.6	27.8	43.9
33	26.96	515	23.2	32.8	52.0
34	45.82	690	30.3	42.8	68.0
35	63.76	768	35.7	50.0	80.0

\*Not recommended for 100% duty cycle.

- Well-suited for battery operation.



See the "Battery Operated Solenoids" section for complete information.

## Specifications

Dielectric Strength	1000 VRMS
Recommended Minimum Heat Sink	Maximum watts dissipated by solenoid are based on an unrestricted flow of air at 20°C, with solenoid mounted on the equivalent of an aluminium plate measuring 86 mm square by 3.2 mm thick
Thermal Resistance	10.8 (°C/watt)
Rotor Inertia	2.56 (gm-cm <sup>2</sup> )
Weight	85 g
Dimensions	See page C10

## How to Order

Add the coil awg number (0XX) to the part number (for example: to order a 25% duty cycle clockwise rotation unit rated at 12.7 VDC, specify 195927-029).

Please see [www.ledex.com](http://www.ledex.com) (click on Stock Products tab) for our list of stock products available through our distributors.

## Size 2EVM — Typical Torque @ 20°C

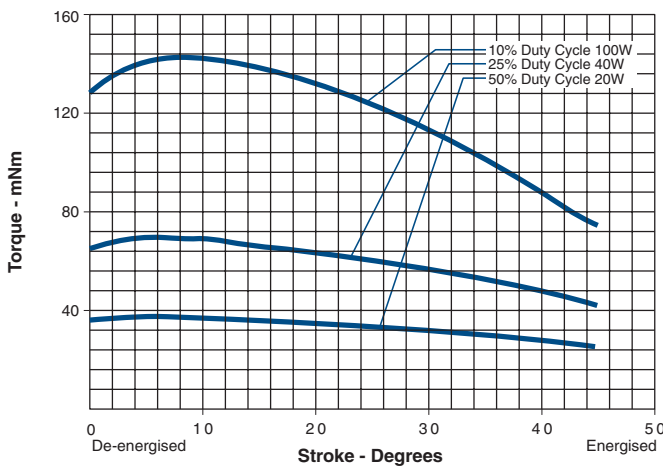

- Continuously pulsed at stated watts and duty cycle
- Single pulse at stated watts (with coil at ambient room temperature 20°C)
- Typical energise time based on a 3.53 mNm torque load including  $1.4 \times 10^{-6}$  kgm<sup>2</sup> of inertia
- Other coil awg sizes available — please consult factory
- Reference number of turns

### Notes:

Torque curves shown are without spring.  
Typical standard spring has a torque of 7.06 mNm.  
Torque values are for reference only.

All specifications subject to change without notice.

# BTA® Size 3EVM

Part Numbers: Clockwise Rotation 195928-0XX  
Counter-Clockwise Rotation 195937-0XX

All catalogue products manufactured after April 1, 2006 are RoHS Compliant

ROTARY BTA®

## Performance

Maximum Duty Cycle	100%	50%	25%	10%		
Maximum ON Time (sec)	∞	10	3	1		
when pulsed continuously <sup>1</sup>						
Maximum ON Time (sec)	∞	26	10	4		
for single pulse <sup>2</sup>						
Typical Energise Time (msec) <sup>3</sup>	25	17	12	9		
Watts (@ 20°C)	13	26	52	130		
Ampere Turns (@ 20°C)	362	512	729	1,144		
Coil Data						
awg (0XX) <sup>4</sup>	Resistance (@20°C)	# Turns <sup>5</sup>	VDC (Nom)	VDC (Nom)	VDC (Nom)	VDC (Nom)
23	0.26	44	1.9	2.6	3.7	5.9
24	0.38	50	2.2	3.1	4.4	7.0
25	0.53	56	2.6	3.7	5.2	8.3
26	1.54	126	4.5	6.3	9.0	14.2
27	2.15	140	5.3	7.5	10.6	16.7
28	3.04	158	6.3	8.9	12.6	19.9
29	4.24	176	7.4	10.5	14.9	23.5
30	9.16	297	10.9	15.4	21.8	34.5
31	12.90	333	12.9	18.3	25.9	40.9
32	18.04	372	15.3	21.6	30.6	48.4
33	34.10	552	21.0	29.8	42.1	66.5
34	47.70	616	25.0	35.2	49.8	78.7

## Specifications

Dielectric Strength	1,000 VRMS (23-28 awg); 1,200 VRMS (29-34 awg)
Recommended Minimum Heat Sink	Maximum watts dissipated by solenoid are based on an unrestricted flow of air at 20°C, with solenoid mounted on the equivalent of an aluminium plate measuring 117 mm square by 3.2 mm thick
Thermal Resistance	8.53 (°C/watt)
Rotor Inertia	9.14 (gm-cm <sup>2</sup> )
Weight	142 g
Dimensions	See page C10

## How to Order

Add the coil awg number (0XX) to the part number (for example: to order a 25% duty cycle clockwise rotation unit rated at 25.9 VDC, specify 195928-051).

Please see [www.ledex.com](http://www.ledex.com) (click on Stock Products tab) for our list of stock products available through our distributors.

- Continuously pulsed at stated watts and duty cycle
- Single pulse at stated watts (with coil at ambient room temperature 20°C)
- Typical energise time based on a 5.65 mNm torque load including 1.4 x 10<sup>-6</sup> kgm<sup>2</sup> of inertia
- Other coil awg sizes available — please consult factory
- Reference number of turns

## Size 3EVM — Typical Torque @ 20°C

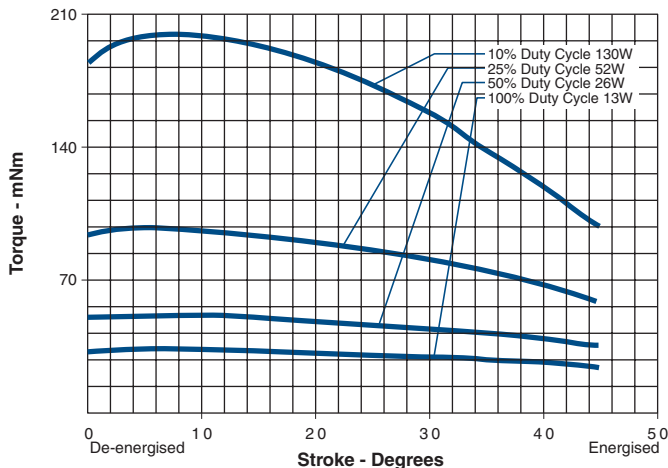

### Notes:

Torque curves shown are without spring.

Typical standard spring has a torque of 13.4 mNm

Torque values are for reference only.

All specifications subject to change without notice.

# BTA<sup>®</sup> Size 4EVM

Part Numbers: Clockwise Rotation 195929-0XX  
Counter-Clockwise Rotation 195938-0XX

All catalogue products manufactured after April 1, 2006 are RoHS Compliant

## Performance

Maximum Duty Cycle	100%	50%	25%	10%		
Maximum ON Time (sec)	∞	40	15	4		
when pulsed continuously <sup>1</sup>						
Maximum ON Time (sec)	∞	108	34	9		
for single pulse <sup>2</sup>						
Typical Energise Time (msec) <sup>3</sup>	27	19	14	10		
Watts (@ 20°C)	14.5	29	58	145		
Ampere Turns (@ 20°C)	510	721	1020	1613		
Coil Data						
awg (0XX) <sup>4</sup>	Resistance (@20°C)	# Turns <sup>5</sup>	VDC (Nom)	VDC (Nom)	VDC (Nom)	VDC (Nom)
23	0.71	104	3.2	4.5	6.4	10.1
24	1.54	174	4.7	6.7	9.4	14.9
25	2.15	195	5.6	7.9	11.2	17.6
26	3.01	219	6.6	9.3	13.2	20.9
27	5.78	328	9.2	12.9	18.3	28.9
28	8.09	368	10.8	15.3	21.7	34.3
29	14.40	515	14.5	20.4	28.9	45.7
30	20.11	575	18.9	26.7	37.7	59.6
31	34.40	774	22.3	31.6	44.6	71.0
32	56.60	1008	28.7	40.5	57.0	91.0
33	91.40	1288	36.0	52.0	73.0	115.0

## Specifications

Dielectric Strength	1000 VRMS (23-24 awg); 1200 VRMS (25-33 awg)
Recommended Minimum Heat Sink	Maximum watts dissipated by solenoid are based on an unrestricted flow of air at 20°C. with solenoid mounted on the equivalent of an aluminium plate measuring 159 mm square by 3.2 mm thick
Thermal Resistance	7.63 (°C/watt)
Rotor Inertia	13.92 (gm-cm <sup>2</sup> )
Weight	227 g
Dimensions	See page C10

## How to Order

Add the coil awg number (0XX) to the part number (for example: to order a 25% duty cycle clockwise rotation unit rated at 15.2 VDC, specify 195929-026).

Please see [www.ledex.com](http://www.ledex.com) (click on Stock Products tab) for our list of stock products available through our distributors.

- 1 Continuously pulsed at stated watts and duty cycle
- 2 Single pulse at stated watts (with coil at ambient room temperature 20°C)
- 3 Typical energise time based on a 5.65 mNm torque load including  $1.4 \times 10^{-6}$  kgm<sup>2</sup> of inertia
- 4 Other coil awg sizes available — please consult factory
- 5 Reference number of turns

## Size 4EVM — Typical Torque @ 20°C

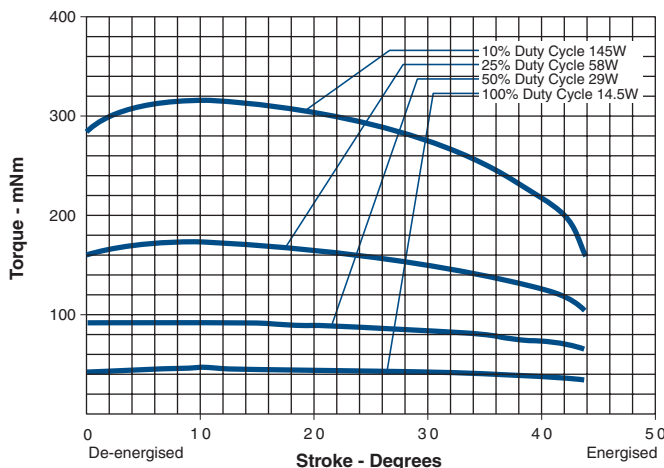

### Notes:

Torque curves shown are without spring.

Typical standard spring has a torque of 21.2 mNm.

Torque values are for reference only.

All specifications subject to change without notice.

# BTA® Size 5EVM

Part Numbers: Clockwise Rotation 195930-0XX  
Counter-Clockwise Rotation 195939-0XX

All catalogue products manufactured after April 1, 2006 are RoHS Compliant

ROTARY BTA®

## Performance

	100%	50%	25%	10%		
Maximum Duty Cycle	100%	50%	25%	10%		
Maximum ON Time (sec)	∞	40	15	4		
when pulsed continuously <sup>1</sup>						
Maximum ON Time (sec)	∞	109	36	10		
for single pulse <sup>2</sup>						
Typical Energise Time (msec) <sup>3</sup>	27	18	14	10		
Watts (@ 20°C)	21	42	84	210		
Ampere Turns (@ 20°C)	621	878	1242	1964		
Coil Data						
awg (0XX) <sup>4</sup>	Resistance (@20°C)	# Turns <sup>5</sup>	VDC (Nom)	VDC (Nom)	VDC (Nom)	VDC (Nom)
23	1.05	128	4.7	6.6	9.4	14.8
24	2.24	213	6.9	9.7	13.7	21.7
25	3.16	240	8.1	11.5	16.3	25.8
26	4.45	270	9.7	13.7	19.3	30.6
27	8.50	404	13.4	18.9	26.7	42.2
28	11.90	452	15.8	22.3	31.6	50.0
29	21.10	630	21.0	29.7	42.1	67.0
30	29.50	705	24.9	35.2	49.8	78.7
31	50.30	948	32.5	46.0	65.0	103.0
32	82.70	1232	41.7	59.0	83.0	132.0
33	134.00	1576	53.0	75.0	106.0	168.0

## Specifications

Dielectric Strength	1000 VRMS (23 awg); 1200 VRMS (24-33 awg)
Recommended Minimum Heat Sink	Maximum watts dissipated by solenoid are based on an unrestricted flow of air at 20°C, with solenoid mounted on the equivalent of an aluminium plate measuring 191 mm square by 3.2 mm thick
Thermal Resistance	5.36 (°C/watt)
Rotor Inertia	30.36 (gm-cm <sup>2</sup> )
Weight	382 gms
Dimensions	See page C10

## How to Order

Add the coil awg number (0XX) to the part number (for example: to order a 25% duty cycle clockwise rotation unit rated at 26.7 VDC, specify 195930-027).

Please see [www.ledex.com](http://www.ledex.com) (click on Stock Products tab) for our list of stock products available through our distributors.

- Continuously pulsed at stated watts and duty cycle
- Single pulse at stated watts (with coil at ambient room temperature 20°C)
- Typical energise time based on a 35.3 mNm torque load including 1.4 x 10<sup>-6</sup> kgm<sup>2</sup> of inertia
- Other coil awg sizes available — please consult factory
- Reference number of turns

## Size 5EVM — Typical Torque @ 20°C

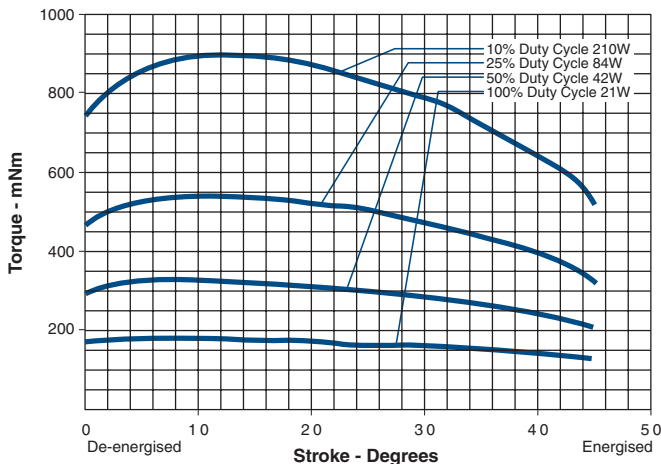

### Notes:

Torque curves shown are without spring.

Typical standard spring has a torque of 28.3 mNm..

Torque values are for reference only.

All specifications subject to change without notice.

# BTA® Size 6EVM

Part Numbers: Clockwise Rotation 195931-0XX  
Counter-Clockwise Rotation 195940-0XX

All catalogue products manufactured after April 1, 2006 are RoHS Compliant

## Performance

	100%	50%	25%	10%		
Maximum Duty Cycle	100%	50%	25%	10%		
Maximum ON Time (sec)	∞	40	15	5		
when pulsed continuously <sup>1</sup>						
Maximum ON Time (sec)	∞	143	47	11		
for single pulse <sup>2</sup>						
Typical Energise Time (msec) <sup>3</sup>	48	21	15	11		
Watts (@ 20°C)	32	64	128	320		
Ampere Turns (@ 20°C)	980	1386	1960	3100		
Coil Data						
avg (0XX) <sup>4</sup>	Resistance (@20°C)	# Turns <sup>5</sup>	VDC (Nom)	VDC (Nom)	VDC (Nom)	VDC (Nom)
23	2.65	267	9.2	13.0	18.4	29.1
24	5.02	396	12.7	17.9	25.4	40.1
25	7.03	444	15.0	21.2	30.0	47.4
26	12.60	625	20.1	28.4	40.2	63.5
27	17.60	700	23.8	33.6	47.5	75.1
28	29.90	936	30.9	43.7	61.9	97.8
29	49.50	1225	39.8	56.0	80.0	126.0
30	79.70	1560	51.0	71.0	101.0	160.0
31	126.50	1962	64.0	90.0	127.0	201.0
32	198.30	2440	80.0	113.0	159.0	252.0
33	306.20	2992	99.0	140.0	198.0	313.0

## Specifications

Dielectric Strength	1,000 VRMS (23 awg); 1200 VRMS (24-33 awg)
Recommended Minimum Heat Sink	Maximum watts dissipated by solenoid are based on an unrestricted flow of air at 20°C. with solenoid mounted on the equivalent of an aluminium plate measuring 314 mm square by 3.2 mm thick
Thermal Resistance	3.58 (°C/watt)
Rotor Inertia	67.15 (gm-cm <sup>2</sup> )
Weight	709 gms
Dimensions	See page C10

## How to Order

Add the coil awg number (0XX) to the part number (for example: to order a 25% duty cycle clockwise rotation unit rated at 25.4 VDC, specify 195931-024).

Please see [www.ledex.com](http://www.ledex.com) (click on Stock Products tab) for our list of stock products available through our distributors.

- Continuously pulsed at stated watts and duty cycle
- Single pulse at stated watts (with coil at ambient room temperature 20°C)
- Typical energise time based on a 99 mNm torque load including  $1.4 \times 10^{-6}$  kgm<sup>2</sup> of inertia
- Other coil awg sizes available — please consult factory
- Reference number of turns

## Size 6EVM — Typical Torque @ 20°C

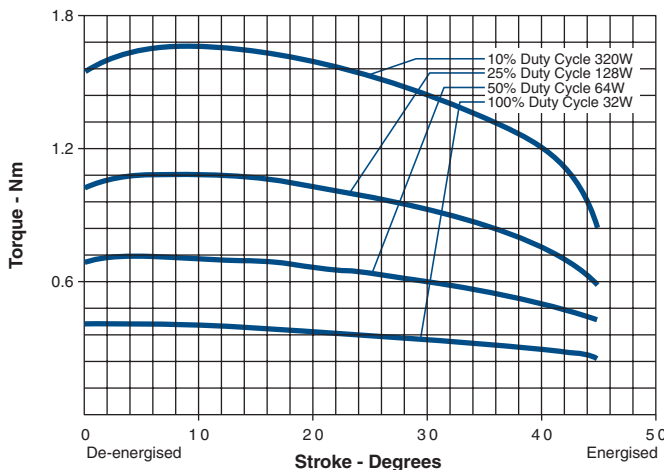

### Notes:

Torque curves shown are without spring.

Typical standard spring has a torque of 56.5 mNm.

Torque values are for reference only.

All specifications subject to change without notice.

# BTA® Dimensions

inches (mm)

ROTARY BTA®

## Size 2EVM

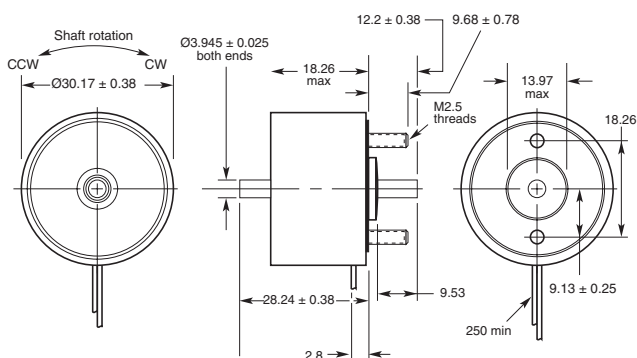

## Size 3EVM

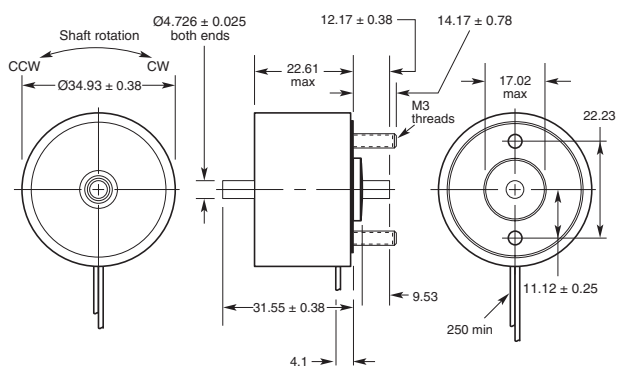

## Size 4EVM

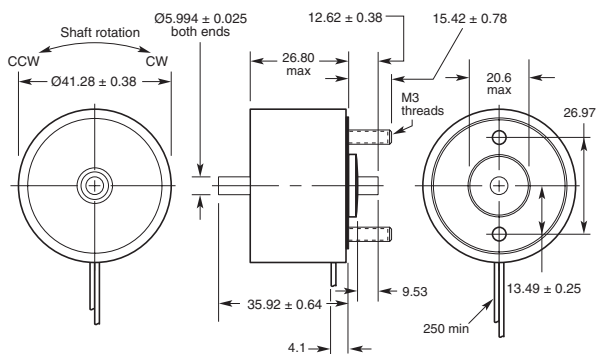

## Size 5EVM

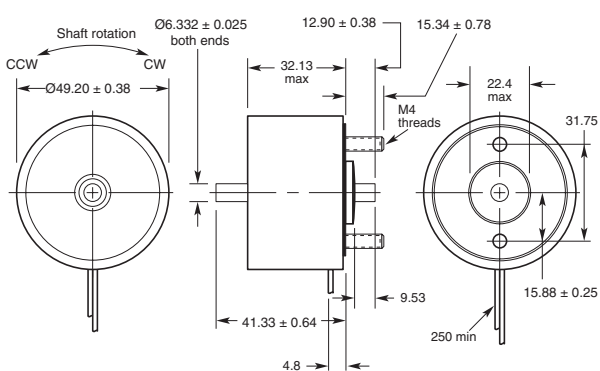

## Size 6EVM

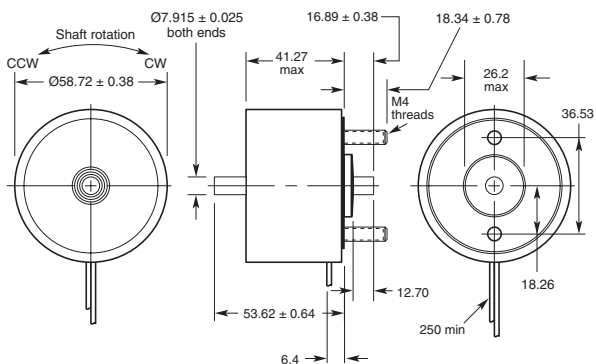

All specifications subject to change without notice.

## Ledex<sup>®</sup> Rotary Solenoids



Maximum Duty Cycle	100%	50%	25%	10%	5%
Maximum ON Time (sec) when pulsed continuously <sup>1</sup>	∞	100	36	8	2.8
Maximum ON Time (sec) for single pulse <sup>2</sup>	∞	162	44	9	3.2
Watts (@ 20°C)	10	20	40	100	200
Ampere Turns (@ 20°C)	550	785	1,100	1,740	2,464
Coil Data					
awg	Resistance			VDC	VDC

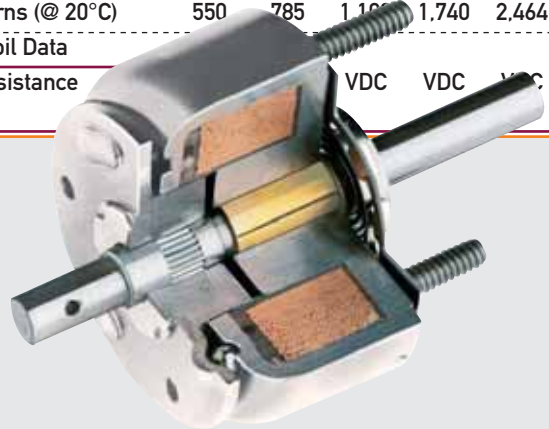

# Ledex® Rotary Solenoids

## ROTARY Solenoids



- The most extensive rotary solenoid line in the industry
- Extensive capabilities for modified, custom fabricated solenoids and solenoid-operated mechanisms
- Quantity orders for standard products delivered in 4–8 weeks
- Fast, two-week turnaround on prototypes, small orders or custom models



All catalogue products manufactured after April 1, 2006 are RoHS Compliant

### Bobbin Wound Coil Rotary Solenoids

- Manufactured by automated high-speed coil winding equipment for good performance and low cost
- Torque output up to 1.15 Nm
- One million operations life rating (based on 25% duty cycle at 20°C ambient operating temperature)
- Standard strokes from 25°–110°; custom strokes available, some with one-time tooling charge
- Clockwise and counterclockwise rotation
- Wide variety of configurations to accommodate mounting and environmental considerations
- Many models available from distribution

### Precision Standard Coil Rotary Solenoids

- Precision wound coil for excellent torque to size ratio
- Available in standard or long life versions
- Torque output up to 5.3 Nm
- One million operations life rating for standard versions; 50 million operations or 100 million operation if lubricated every 10 million operations for long life versions (life ratings based on 25% duty cycle at 20°C ambient operating temperature)
- Three sizes from 47.6 mm to 70 mm diameters
- Standard strokes from 25°–110°; custom strokes available, some with one-time tooling charge
- Clockwise or counterclockwise rotation
- Wide variety of configurations to accommodate mounting and environmental considerations

### Precision Elongated Coil Rotary Solenoids

- Built with 30% more coil copper than precision standard coil solenoids for lower power consumption
- Precision wound coil for excellent torque to size ratio
- Available in standard or long life versions
- Torque output up to 5.9 Nm
- One million operations life rating for standard versions; 50 million operations or 100 million operations if lubricated every 10 million operations for long life versions (life ratings based on 25% duty cycle at 20°C ambient operating temperature)
- Four sizes from 25 to 40 mm diameters
- Standard strokes from 25°–110°; custom strokes available, some with one-time tooling charge
- Clockwise or counterclockwise rotation
- Wide variety of configurations to accommodate mounting and environmental considerations
- Many models available from distribution

# Ledex® Rotary Solenoids

## Modified and Custom-Designed Rotary Solenoids

Ledex offers comprehensive design and manufacturing resources to develop application specific rotary solenoids to meet your exact performance and unit cost objectives. Even though we offer thousands of standard rotary solenoid models, almost 80% of the product we build is specifically tailored to our customers' needs. So if you don't find exactly what you're looking for, please call us to discuss your requirements. Here are a few simple design options which we frequently encounter for rotary solenoid applications:

- Special shafts
- Mounting studs threaded to customer specification
- Slots, flats, or holes in shafts for machine linkage
- Double return springs for critical safety redundancy
- Armature covers

## Design Principles

### Physical Characteristics

The rotary solenoid is a compact and rugged direct current electromagnet—almost solid steel and copper so as to give maximum power output with minimum size and weight. The coil is wound by a special precision winding process which puts the maximum amount of copper into the allowable space, thus resulting in each solenoid developing a tremendous torque for its size and power output. Heat-treated steel surrounds and protects the coil. The steel also provides a magnetic path of high permeability and low residual flux characteristics for efficient conversion of electrical energy to mechanical energy and fast response.

### Determining Rotary Stroke

The three ball races which determine the rotary stroke are produced by a coining process. The coining of the solenoid case and armature plate determines the length and direction of the stroke and the value of starting torque. Refer to the selection charts for the standard strokes available. Special rotary strokes can be engineered for solenoids which are made to order.

### Converting Linear to Rotary Motion

The rotary solenoid armature is supported by three ball bearings that travel around and down inclined ball races. When power is applied, a powerful linear electromagnetic force pulls in the armature. Rotation continues until the balls have traveled to the deep ends of the races. The result is almost frictionless conversion from linear to rotary motion.

### High Starting Torque

In ordinary electromagnets, magnetic pull increases sharply as the air gap closes. In Ledex rotary solenoids, this is compensated for by the compound angle of incline of the ball races. The incline of the ball races is steep at the beginning of the rotary stroke and gradually decreases as the balls approach the deep end of the ball races, thus transferring torque to the start of the rotary stroke where it is usually needed.

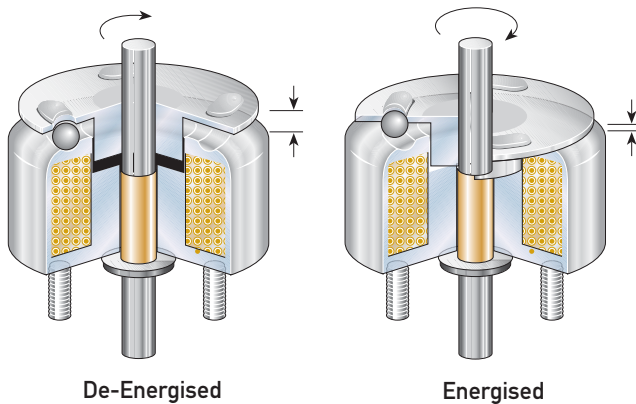

# Ledex® Rotary Solenoids Design Considerations

## Rotary Stroke Considerations

Determine whether clockwise or counterclockwise rotation (as viewed from the armature side, opposite the mounting studs) is required.

Match the stroke of the solenoid selected to the rotary stroke required for the application. For example: do not use a 45° stroke solenoid when only 35° of stroke is needed.

The complete rotary stroke of the solenoid should be utilised. It is the contour of the ball race that determines the torque output, but if the armature is not allowed to completely energise or de-energise, the starting torque and ending torque will deviate from the designed torque output.

In some applications, however, users of standard Ledex solenoids have achieved good results with certain methods of restricting the rotary

stroke. If some mechanical means is used to prevent the balls from reaching the deepest part of the races, increased life expectancy and quieter operation can be achieved. However, if the stroke is restricted, it is often necessary that some additional bearing method be employed to keep the balls in phase. Our application engineers will be glad to assist you with any unusual requirements.

When strokes other than those shown in this catalogue are needed in production quantities, it is usually best to consider tooling to produce the exact stroke needed.

### Starting Torque

When determining an application's torque requirement, apply a 1.5 safety factor. For example: a load requiring 0.50 Nm of torque should utilise a solenoid providing 0.5 x 1.5 or 0.75 Nm of torque.

## Other Design Considerations

### Snap-Acting Engagement

Rotary solenoids have fast acting engagement. If a controlled speed is required in a rotary stroke application, consider Ledex BTA rotary actuators.

### Unobstructed Axial Stroke

Axial stroke is the linear distance that the armature travels to the centre of the coil as the solenoid is energised and the three bearing balls travel to the lower ends of the races.

The application should allow clearance for axial stroke, which is rarely a problem due to the relatively small magnitude of travel. Axial stroke is listed for each solenoid size and rotary stroke on the appropriate specification pages.

Solenoids without axial stroke, such as our BTA, can be tailored to your application if longitudinal movement must be avoided.

### Preloaded Axial Stroke

A rotary solenoid's armature produces smoother action if it is preloaded axially. It is important that the three bearing balls be kept in phase throughout the entire stroke. If they are allowed to move freely in the raceway, operation may become erratic.

### Torque and Stroke

Torque is inversely proportional to the total length of the rotary stroke. If, for example, a rotary solenoid with a 90° stroke produces a gross starting torque of 0.09 Nm, it will have approximately 0.19 Nm of torque if it has a 45° stroke, and 0.34 Nm with a 25° stroke.

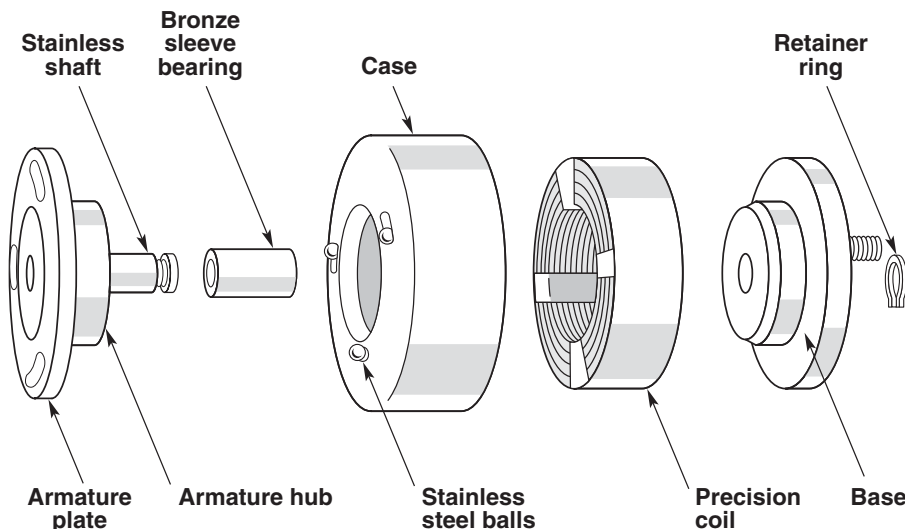
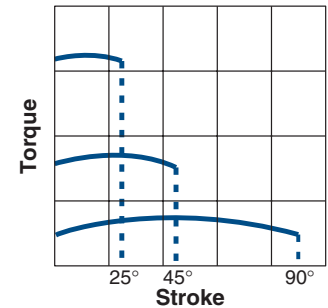

# Ledex® Rotary Solenoids Design Considerations

## Other Design Considerations (continued)

### Torque and Duty Cycle

Ledex rotary solenoids are engineered to deliver a relatively flat output curve at 25% duty.

Under highly intermittent usage such as 10% or 5% duty, power and magnetic saturation are increased. This results in a higher starting torque, but a faster reduction of torque as the armature progresses through the rotary stroke. Since most loads have some inertia, the effect of less torque toward the end of the stroke is usually negligible. At continuous duty, magnetic saturation is lower and the torque output typically increases slightly toward the end of stroke.

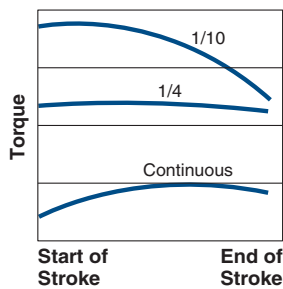

### Temperature Considerations

Rotary solenoids are designed for operation in ambient temperatures ranging from -55°C to 80°C, provided the coil temperature does not exceed 120°C. Note that standard and elongated solenoids have PVC lead wires which have a maximum rating of 105°C. Special order Teflon leads are available (with maximum temperature rating of 200°C to allow for a 175°C coil temperature.)

### Armature Drive Pin

Armature pins are commonly used as the main power take-off to perform secondary drive operations. They also provide a convenient adaptor for levers or bars which can convert the rotary stroke into linear motion. With appropriately designed linkages, a limited rotary stroke can produce several inches of linear travel.

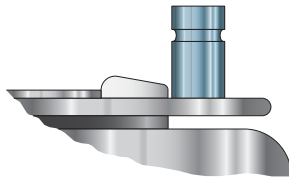

### Armature Cover

Armature covers are available on all models, sizes and styles. They keep adjacent components or wires from interfering with the rotary and axial motion of the solenoid armature. They are also recommended for dirty or dusty environments. Armature cover models with armature end shaft extensions are equipped with a felt washer to act as a seal against the entry of dust around the shaft.

### Coil Style

Ledex offers three rotary solenoid coil designs to accommodate most price and performance considerations.

Bobbin Coil Style solenoids (Sizes 3B and 5B only) offer good performance, long life and cost less than Precision Standard Coil

Style solenoids. However, Bobbin Style solenoids provide somewhat less torque in a slightly taller package. Bobbin Style Solenoids are equipped with either solder lug terminals or lead wires.

Precision Standard Coil Style solenoids (Sizes 5S through 7S) are designed with precision wound coils to provide excellent performance and long life. Precision Standard solenoids are equipped with 250 mm PVC insulated lead wires.

Precision Elongated Coil Style solenoids (sizes 1E through 4E) also have precision-wound coils like our standard models, except the coil has 30% more copper. The larger coil enables Elongated styles to operate with additional torque at most power levels to provide an additional safety factor when compared to standard S style torque ratings. Consequently, Precision Elongated Coil Solenoids are generally recommended for applications which have relatively long duty cycle ON times. Precision elongated coils, in comparison to standard coils, weigh 20–25% more, have the same diameter and mounting configurations and are equipped with 250 mm PVC insulated lead wires.

### Configurations

Rotary solenoids are available in seven standard configurations for most sizes:

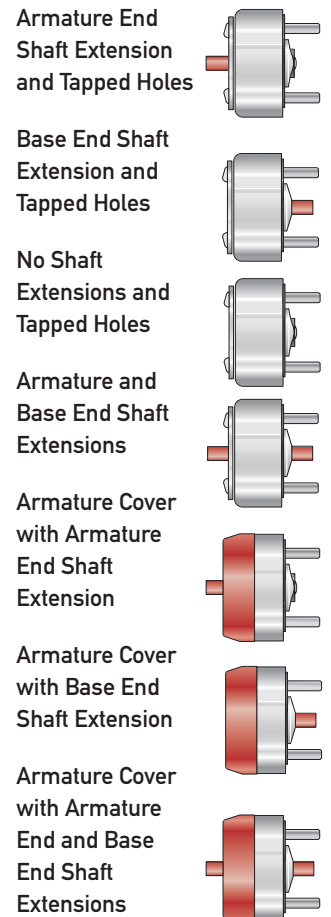

These icons are used throughout the rotary solenoid section to help distinguish the seven configurations. All standard configurations include a return spring (See return spring torque specifications on page D7.) Models without an armature cover are equipped with three tapped holes in the armature face for load attachment purposes.

# Ledex® Rotary Solenoids Design Considerations

## Life Ratings

Rotary solenoids are laboratory tested under spring load conditions at 25% duty cycle at 20° C ambient temperature to determine life ratings. Bobbin, Precision Standard, and Precision Elongated coil solenoids are rated for 1 million actuations.

Actual life, however, is greatly affected by the application and environment factors such as exposure to extreme temperatures, dirt, dust, etc. Depending on these factors, Precision Standard and Precision Elongated coil solenoids can provide up to 20 million actuations.

## Long Life Versions

Precision Standard and Precision Elongated coil solenoids are also available in long life versions which provide 50 million actuations (or 100 million actuations if lubricated every 10 million actuations).

Long life models incorporate precision needle bearings and special materials to reduce wear and extend life. The needle bearing is particularly helpful in overcoming side load and starting torque problems.

Long life models provide approximately 90% of the charted torque listed in the performance charts. Long life models are slightly more expensive, but can cost less in terms of machine down time and replacement time. Long life versions are available in strokes up to 45°.

## Duty Cycle

Duty cycle is determined by solenoid ON time/(ON + OFF time).

For example: a solenoid is actuated for 30 seconds, then off for 90 seconds.  
 $30 \text{ sec ON} / (30 \text{ Sec ON} + 90 \text{ sec OFF}) = 30/120 = 1/4 \text{ or } 25\% \text{ duty cycle}$

Ledex rates rotary solenoids for various duty cycles ranging from 100% to 5% duty.

If you cannot find an appropriate Style B Bobbin Coil solenoid which provides satisfactory torque and power, consider S Style Precision Standard Coil, or E Style Precision Elongated Coil models.

## Maximum ON Time and Duty Cycle

Note that the maximum ON time for a particular application can be a factor which overrides the duty cycle rating.

For example, the maximum ON time for a given rotary solenoid when pulsed continuously at 25% duty cycle at given wattage is 36 seconds. If, however, the solenoid is given a single pulse at the same wattage with the unit at ambient temperature (20°C), then the maximum ON time is extended somewhat to 44 seconds. Maximum ON time ratings are charted by duty cycle on the following selection pages as well as on the individual specification pages.

## Power Requirement

Standard solenoids are available in coil awgs ranging, in most instances, from #23 up to #33 to accommodate your input power. Refer to selection charts on the following pages. The coil awg number will determine the power rating of the coil. The coil awg number must be specified when ordering a unit. Many other awg coil sizes are available; please contact an application engineer to discuss your requirements.

## Return Springs

Return springs are employed to return the solenoid armature to its de-energised position, and can also serve to return light loads. Standard nominal settings listed below are accurate to ±20%.

Size/Style	Spring Torque (mNm)
1E	7.1
2E	7.1
3B: 3E	14.1
4E	21.2
5B: 5S	28.2
6S	56.6
7S	84.7

To meet exacting application requirements, rotary solenoids can be equipped with lesser or higher torsion return springs.

Contact our application engineers for your specific requirements.

# Ledex® Rotary Solenoids Modifications & Custom Capabilities

## Modifications and Customised Units

For modifications including heavy duty return springs, drive pins, etc. please contact our application engineers for assistance, as these standard modifications require a custom part number.

And, if you can't find exactly what you're looking for among our catalogue products, please give our application engineers a call. Ledex custom fabricated solenoids are designed, built, tested, packaged, and shipped to your exact specifications. Whether it's as simple as adding a special connector or mounting bracket, or fabricating a complete assembly, we can build the right product to meet both your design and budget objectives.

## Three Tapped Holes in Armature Plate

Attachment screws used should not extend below the bottom surface of the armature plate or they may interfere with the rotary stroke.

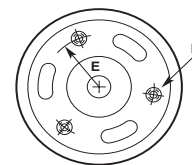

Solenoid Size	1E	2E	3B 3E	4E	5B 5S	6S	7S
Radius (E) mm	8.3	9.5	11.1	13.5	14.3	19.1	23.8
Thread Size (F)	M2.5 x 0.45	M2.5 x 0.45	M3 x 0.5	M4 x 0.7	M4 x 0.7	M5 x 0.8	M6 x 1

## Return Springs

### Scroll Type Standard or Heavy Duty Fixed Springs

The primary purpose of the return spring is to return the solenoid armature; it can also be used to return light loads. Standard nominal settings, which are accurate to within  $\pm 20\%$ , are charted below opposite "standard." Springs with greater torsion values can be supplied (see values opposite "Heavy Duty" below).

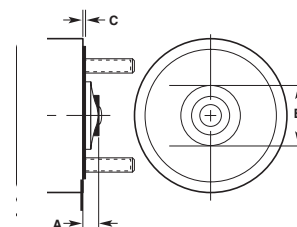

Solenoid Size	1E	2E	3B 3E	4E	5B 5S	6S	7S
Dim. A mm	4.0	4.0	4.4	5.2	5.6	6.3	7.9
Dim. B mm	13.9	13.9	17.1	20.6	22.2	26.2	29.8
Dim. C mm	0.4	0.4	0.4	0.8	0.8	0.8	0.8

### Nominal Spring Setting: $\pm 20\%$ mNm

Standard	7.06	7.06	14.12	21.19	28.25	56.60	84.74
Heavy Duty	—	—	14.12	28.25	35.31	56.60	112.99

# Ledex® Rotary Solenoids Selection

## How to Select Rotary Solenoids

1. Use the chart on page D9 to determine which coil style and frame size best satisfies your application requirement. Turn to the specification pages listed for model selection.

2. On the individual specification pages, use the Performance Chart (like the one shown at right), to select one of the five columns which provides the appropriate duty cycle for your application (for example 25%). Reading down this column, locate the torque for the stroke you need.

3. Use the model number and configuration chart (like the one at the bottom of this page) to select the model number corresponding to your desired design, stroke, and direction of rotation.

4. Using the Coil Specification Chart (like the one at right), find your selected duty cycle column. Reading down this column provides a variety of specification data. Following further down the column into the VDC ratings, select the voltage which most closely matches your supply voltage (for example, for a 24 VDC supply, select 26.0). Read across to the left to select the coil awg suffix for this voltage.

5. Replace the last two digits of the model number (XX) with the coil awg number to complete the model number. (For this example, specify model number: M-15039-033).

## Performance Specifications

Stroke	Holding Torque <sup>2</sup> (mNm)	Starting Torque (mNm) @ 20°C Maximum Duty Cycle				
		100%	50%	25%	10%	5%
25°	31.6	*	22.6	45.2	90.4	124.3
35°	*	*	*	*	*	*
45°	16.9	*	11.3	22.6	45.2	67.8

## Coil Specifications

	100%	50%	25%	10%	5%
Maximum Duty Cycle	∞	100	36	7	2.5
Maximum ON Time (sec) when pulsed continuously	∞	162	44	8	2.8
Maximum ON Time (sec) for single pulse	*	10.5	21	54	108
Watts (@ 20°C)	*	492	695	1,105	1560

## Coil Data

avg (0XX)	Resistance (@20°C)	# Turns	VDC (Nom)	VDC (Nom)	VDC (Nom)	VDC (Nom)	VDC (Nom)
25	0.83	140	*	2.9	4.1	6.5	9.2
26	1.38	186	*	3.7	5.2	8.2	11.6
27	1.91	210	*	4.5	6.3	10.1	14.2
28	3.17	273	*	5.7	8.1	12.8	18.1
29	5.17	352	*	7.2	10.2	16.2	23.0
30	8.25	441	*	9.2	13.0	21.0	29.0
31	12.95	550	*	11.6	16.4	26.0	37.0
32	20.71	682	*	14.9	21.0	34.0	47.0
33	30.60	828	*	18.2	26.0	41.0	58.0
34	50.95	1078	*	23.0	33.0	52.0	74.0
35	83.92	1392	*	30.0	42.0	67.0	94.0

- Armature cover
- Armature end shaft
- Return Spring

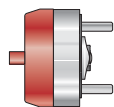

- Armature cover
- Base end shaft
- Return spring

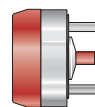

- Armature cover
- Double shaft
- Return spring

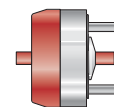

Stroke/ Direction*	Nom. Axial Stroke	Standard		Long Life		Standard		Long Life	
		Standard	Long Life	Standard	Long Life	Standard	Long Life		
25°CW	0.6	M-1142-0XX	E-1142-0XX	M-1140-0XX	E-1140-0XX	M-15097-0XX	E-15097-0XX	M-3334-0XX	E-3334-0XX
25°CCW	0.6	M-1145-0XX	E-1145-0XX	M-1144-0XX	E-1144-0XX	M-15207-0XX	E-15207-0XX	M-15208-0XX	E-15208-0XX
35°CW	0.8	M-15201-0XX	E-15201-0XX	M-15205-0XX	E-15205-0XX	M-15207-0XX	E-15207-0XX	M-15208-0XX	E-15208-0XX
35°CCW	0.8	M-15202-0XX	E-15202-0XX	M-15206-0XX	E-15206-0XX	M-15207-0XX	E-15207-0XX	M-15208-0XX	E-15208-0XX
45°CW	0.6	M-1148-0XX	E-1148-0XX	M-1147-0XX	E-1147-0XX	M-15039-0XX	E-15039-0XX	M-15148-0XX	E-15148-0XX
45°CCW	0.6	M-1150-0XX	E-1150-0XX	M-1149-0XX	E-1149-0XX	M-15148-0XX	E-15148-0XX	M-15148-0XX	E-15148-0XX

\*Direction of rotation (cw – clockwise or ccw – counterclockwise) is viewed from the armature end of the solenoid opposite the mounting studs.

Note: The XX in the part number suffix must be filled in with the awg of your choice.

# Ledex® Rotary Solenoids Selection

## Rotary Solenoids Selection Overview

Size/ Series	Diameter <sup>1</sup> (mm)	Height <sup>1</sup> (mm)	Stroke	Direction CW CCW		Holding Torque (mNm)	Available Torque <sup>2</sup> (mNm)					Energizing Time (msec) @ Specified Duty Cycles					Return Spring (mNm)	
							100% Duty	50% Duty	25% Duty	10% Duty	5% Duty	100% Duty	50% Duty	25% Duty	10% Duty	5% Duty		
1E ●	25.40	15.80	25°	•	•	31.6	*	22.6	45.2	90.4	124.3	12.6	9.9	7.3	5.7	4.7	6.8	
			35°	•	•	*	*	*	*	*	*	*	*	*	*	*	*	*
			45°	•	•	16.9	*	11.3	22.6	45.2	67.8	19.8	14.2	10.0	7.2	6.0	6.8	
2E ●	28.58	16.67	25°	•	•	56.5	22.6	45.2	79.1	158.2	192.1	13.1	9.5	7.5	5.9	5.0	6.8	
			35°	•	•	*	22.6	33.9	56.5	124.3	146.9	*	*	*	*	*	*	*
			45°	•	•	33.9	11.3	22.6	45.2	79.1	101.7	23.2	15.0	11.0	8.4	7.0	6.8	
3B	33.32	22.22	25°	•	•	101.7	45.2	79.1	146.9	305.1	361.6	16.5	11.3	8.9	6.8	5.9	13.6	
			35°	•	•	67.8	33.9	67.8	113.0	226.0	259.9	*	*	*	*	*	*	*
			45°	•	•	45.2	22.6	45.2	90.4	158.2	192.1	24.0	15.6	12.1	9.4	7.7	13.6	
			67½°	•	•	45.2	11.3	22.6	45.2	56.5	90.4	*	*	*	*	*	*	*
3E	33.32	20.24	25°	•	•	101.7	45.2	90.4	158.2	305.1	361.6	16.9	12.0	9.3	7.1	6.2	13.6	
			35°	•	•	79.1	33.9	67.8	113.0	226.0	259.9	*	*	*	*	*	*	*
			45°	•	•	67.8	22.6	45.2	90.4	158.2	203.4	29.8	17.8	13.1	10.0	8.1	13.6	
			67½°	•	•	56.5	11.3	22.6	45.2	79.1	101.7	*	*	*	*	*	*	*
4E	39.67	24.20	25°	•	•	226.0	101.7	192.1	350.3	508.5	587.6	19.1	13.9	11.2	8.3	7.2	20.3	
			35°	•	•	*	67.8	124.3	226.0	350.3	395.5	*	*	*	*	*	*	*
			45°	•	•	113.0	45.2	101.7	180.8	293.8	350.3	28.9	20.3	15.4	11.3	9.2	20.3	
			55°	•	•	*	*	*	*	*	*	*	*	*	*	*	*	*
			67½°	•	•	*	22.6	45.2	90.4	180.8	214.7	*	*	*	*	*	*	*
			95°	•	•	101.7	22.6	33.9	67.8	113.0	135.6	*	*	*	*	*	*	*
5B	47.62	30.56	25°	•	•	452.0	203.4	395.5	655.4	937.9	1130.0	19.6	14.9	12.0	9.4	7.7	28.2	
			35°	•	•	*	101.7	237.3	463.3	779.7	937.9	*	*	*	*	*	*	*
			45°	•	•	339.0	79.1	192.1	361.6	565.0	678.0	29.0	21.2	16.5	12.6	10.2	28.2	
			67½°	•	•	*	56.5	124.3	226.0	372.9	452.0	*	*	*	*	*	*	*
			95°	•	•	226.0	22.6	45.2	101.7	180.8	214.7	*	*	*	*	*	*	*
5S	47.62	26.59	25°	•	•	565.5	214.7	463.3	824.9	1367.3	1491.6	18.6	14.3	11.5	9.0	7.2	28.2	
			35°	•	•	*	135.6	293.8	508.5	881.4	1039.6	*	*	*	*	*	*	*
			45°	•	•	339.0	79.1	192.1	384.2	711.9	779.7	28.1	20.3	15.6	12.0	10.0	28.2	
			55°	•	•	*	*	*	*	*	*	*	*	*	*	*	*	*
			67½°	•	•	*	56.5	135.6	248.6	440.7	553.7	*	*	*	*	*	*	*
			75°	•	•	*	*	*	*	*	*	*	*	*	*	*	*	*
			95°	•	•	226.0	22.6	56.5	113.0	214.7	293.8	62.4	36.5	26.1	18.7	15.0	28.2	
6S	57.15	34.11	25°	•	•	1017.0	519.8	1005.7	1830.6	3141.4	3457.8	24.1	18.6	14.8	11.4	9.5	56.5	
			35°	•	•	*	384.2	734.5	1356.0	2101.8	2316.5	*	*	*	*	*	*	*
			45°	•	•	678.0	192.1	395.5	734.5	1243.0	1367.3	38.1	27.4	21.6	16.5	13.5	56.5	
			55°	•	•	*	*	*	*	*	*	*	*	*	*	*	*	*
			67½°	•	•	*	180.8	350.3	632.8	994.4	1096.1	*	*	*	*	*	*	*
			95°	•	•	339.0	101.7	192.1	372.9	587.6	644.1	*	*	*	*	*	*	*
7S	69.85	44.86	25°	•	•	2260.0	1243.0	2689.4	3751.6	4791.2	5265.8	32.3	25.1	20.3	15.6	13.2	84.8	
			35°	•	•	*	678.0	1356.0	2486.0	4294.0	4746.0	*	*	*	*	*	*	*
			45°	•	•	1469.0	565.0	994.4	1853.2	3367.4	3706.4	45.1	33.9	27.2	20.2	16.9	84.8	
			55°	•	•	*	*	*	*	*	*	*	*	*	*	*	*	*
			67½°	•	•	*	282.5	576.3	1107.4	1977.5	2180.9	*	*	*	*	*	*	*
			95°	•	•	678.0	169.5	395.5	723.2	1186.5	1310.8	81.6	58.8	44.8	33.0	27.3	84.8	

All data is at 20°C coil temperature. Torque outputs degrade with elevated temperatures. All specifications subject to change without notice.

<sup>1</sup> Without armature cover

<sup>2</sup> Torque values and energizing times shown for S and E Series are for Standard Life units. Long Life models provide approximately 10% less torque, but offer 5 to 10 times longer life. Long Life models are only available in strokes up to 45°.

\* Consult factory for sizes and strokes not shown.

All catalogue products manufactured after April 1, 2006 are RoHS Compliant

● Well-suited for battery operation. See the "Battery Operated Solenoids" section for complete information.

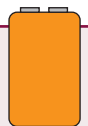

# Ledex® Rotary Solenoids Size 1E Precision Elongated Coil

## Performance Specifications

Stroke	Holding Torque <sup>2</sup> (mNm)	Starting Torque (mNm) <sup>1</sup> @ 20°C Maximum Duty Cycle				
		100%	50%	25%	10%	5%
25°	31.64	*	22.6	45.2	90.4	124.3
35°	*	*	*	*	*	*
45°	16.95	*	11.3	22.6	45.2	67.8

All data is at 20°C coil temperature. Force (torque) outputs degrade with elevated temperatures.

<sup>1</sup> Gross starting torques are shown. For net available starting torque, subtract return spring torque of 6.8 mNm ±20%.

<sup>2</sup> Holding torque is shown at the stabilised temperature of 105°C and continuous duty.

\* Consult factory.

● Well-suited for battery operation. See the "Battery Operated Solenoids" section for complete information.



All catalogue products manufactured after April 1, 2006 are RoHS Compliant

## How to Order

- Using the Performance Chart to the left, select one of the five columns which provides the appropriate duty cycle for your application. Reading down this column locate the torque for the stroke you need. For net available starting torque, subtract return spring torque of 6.8 mNm ±20% (if torque is insufficient go to next larger solenoid size).
- Use the chart below to select the model number corresponding to your desired design, stroke and direction of rotation (as viewed from armature end, opposite mounting studs).
- Using the Specification Chart to the right, select the same duty cycle column. Follow down the column into the VDC ratings. Select the voltage which most closely matches your supply voltage. Read across to the left to select the coil awg suffix.
- Replace the last two digits of the model number (XX) with the coil awg number to complete the part number.

Please see [www.ledex.com](http://www.ledex.com) (click on Stock Products tab) for our list of stock products available through our distributors.

- Armature cover
- Armature end shaft
- Return spring

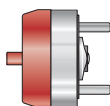

- Armature cover
- Base end shaft
- Return spring

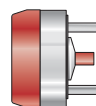

- Armature cover
- Double shaft
- Return spring

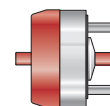

Stroke/ Direction*	Nom. Axial Stroke	Standard		Long Life		Standard		Long Life	
		Standard	Long Life	Standard	Long Life	Standard	Long Life		
25° CW	0.6 mm	M-1142-0XX	E-1142-0XX	M-1140-0XX	E-1140-0XX	M-15097-0XX	E-15097-0XX		
25° CCW	0.6 mm	M-1145-0XX	E-1145-0XX	M-1144-0XX	E-1144-0XX	M-3334-0XX	E-3334-0XX		
35° CW	0.8 mm	M-15201-0XX	E-15201-0XX	M-15205-0XX	E-15205-0XX	M-15207-0XX	E-15207-0XX		
35° CCW	0.8 mm	M-15202-0XX	E-15202-0XX	M-15206-0XX	E-15206-0XX	M-15208-0XX	E-15208-0XX		
45° CW	0.6 mm	M-1148-0XX	E-1148-0XX	M-1147-0XX	E-1147-0XX	M-15039-0XX	E-15039-0XX		
45° CCW	0.6 mm	M-1150-0XX	E-1150-0XX	M-1149-0XX	E-1149-0XX	M-15148-0XX	E-15148-0XX		

\* Direction of rotation (cw – clockwise or ccw – counterclockwise) is viewed from the armature end of the solenoid opposite the mounting studs.

Note: The XX in the part number suffix must be filled in with the awg of your choice.

# Ledex® Rotary Solenoids Size 1E Precision Elongated Coil

## Coil Specifications

Maximum Duty Cycle	100%	50%	25%	10%	5%
Maximum ON Time (sec) when pulsed continuously <sup>1</sup>	∞	100	36	7	2.5
Maximum ON Time (sec) for single pulse <sup>2</sup>	∞	162	44	8	2.8
Watts (@ 20°C)	*	10.5	21	54	108
Ampere Turns (@ 20°C)	*	492	695	1105	1560

### Coil Data

awg (0XX) <sup>3</sup>	Resistance (@20°C)	# Turns <sup>4</sup>	VDC (Nom)	VDC (Nom)	VDC (Nom)	VDC (Nom)	VDC (Nom)
25	0.83	140	*	2.9	4.1	6.5	9.2
26	1.38	186	*	3.7	5.2	8.2	11.6
27	1.91	210	*	4.5	6.3	10.1	14.2
28	3.17	273	*	5.7	8.1	12.8	18.1
29	5.17	352	*	7.2	10.2	16.2	23.0
30	8.25	441	*	9.2	13.0	21.0	29.0
31	12.95	550	*	11.6	16.4	26.0	37.0
32	20.71	682	*	14.9	21.0	34.0	47.0
33	30.60	828	*	18.2	26.0	41.0	58.0
34	50.95	1078	*	23.0	33.0	52.0	74.0
35	83.92	1392	*	30.0	42.0	67.0	94.0

## General Specifications

Dielectric Strength	1000 VRMS, all coils
Recommended Minimum Heat Sink	Maximum watts dissipated by solenoid are based on an unrestricted flow of air at 20°C, with solenoid mounted on the equivalent of an aluminium plate measuring 76.2 mm square by 3.2 mm thick.
Coil Resistance	±5% tolerance
Starting Torque	Gross torque values are shown. For net starting torque, subtract return spring torque
Return Spring Torque	6.8 mNm ±20%
Weight	42.5 g
Dimensions	See page D28

- <sup>1</sup> Continuously pulsed at stated watts and duty cycle.
  - <sup>2</sup> Single pulse at stated watts (with coil at ambient room temperature 20°C).
  - <sup>3</sup> Other coil awg sizes available, consult factory.
  - <sup>4</sup> Reference number of turns.
- \* Consult factory.

All specifications subject to change without notice.

- No shafts
- 3 tapped holes
- Return spring

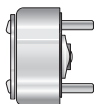

- Armature end shaft
- 3 tapped holes
- Return spring

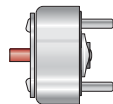

- Base end shaft
- 3 tapped holes
- Return spring

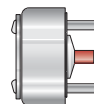

- Double shaft
- 3 tapped holes
- Return spring

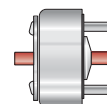

Standard	Long Life	Standard	Long Life	Standard	Long Life	Standard	Long Life
M-1143-0XX	E-1143-0XX	M-15089-0XX	E-15089-0XX	M-15211-0XX	E-15211-0XX	M-15215-0XX	E-15215-0XX
M-1146-0XX	E-1146-0XX	M-3311-0XX	E-3311-0XX	M-15084-0XX	E-15084-0XX	M-15216-0XX	E-15216-0XX
M-15200-0XX	E-15200-0XX	M-15204-0XX	E-15204-0XX	M-15212-0XX	E-15212-0XX	M-1305-0XX	E-1305-0XX
M-15203-0XX	E-15203-0XX	M-15210-0XX	E-15210-0XX	M-15213-0XX	E-15213-0XX	M-15217-0XX	E-15217-0XX
M-1141-0XX	E-1141-0XX	M-3380-0XX	E-3380-0XX	M-15085-0XX	E-15085-0XX	M-15218-0XX	E-15218-0XX
M-1151-0XX	E-1151-0XX	M-1282-0XX	E-1282-0XX	M-15214-0XX	E-15214-0XX	M-15219-0XX	E-15219-0XX

# Ledex® Rotary Solenoids Size 2E Precision Elongated Coil

## Performance Specifications

Stroke	Holding Torque <sup>2</sup> (mNm)	Starting Torque (mNm) <sup>1</sup> @ 20°C Maximum Duty Cycle				
		100%	50%	25%	10%	5%
25°	56.5	22.6	45.2	79.1	158.2	192.17
35°	*	22.6	33.9	56.5	124.3	146.9
45°	33.9	11.3	22.6	45.2	79.1	101.7

All data is at 20°C coil temperature. Force (torque) outputs degrade with elevated temperatures.

<sup>1</sup> Gross starting torques are shown. For net available starting torque, subtract return spring torque of 6.8 mNm ±20%.

<sup>2</sup> Holding torque is shown at the stabilised temperature of 105°C and continuous duty.

\* Consult factory.

● Well-suited for battery operation. See the "Battery Operated Solenoids" section for complete information.



All catalogue products manufactured after April 1, 2006 are RoHS Compliant

## How to Order

- Using the Performance Chart to the left, select one of the five columns which provides the appropriate duty cycle for your application. Reading down this column locate the torque for the stroke you need. For net available starting torque, subtract return spring torque of 6.8 mNm ±20% (if torque is insufficient go to next larger solenoid size).
- Use the chart below to select the model number corresponding to your desired design, stroke and direction of rotation (as viewed from armature end, opposite mounting studs).
- Using the Specification Chart to the right, select the same duty cycle column. Follow down the column into the VDC ratings. Select the voltage which most closely matches your supply voltage. Read across to the left to select the coil awg suffix.
- Replace the last two digits of the model number (XX) with the coil awg number to complete the part number.

Please see [www.ledex.com](http://www.ledex.com) (click on Stock Products tab) for our list of stock products available through our distributors.

- Armature cover
- Armature end shaft
- Return spring

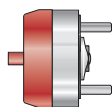

- Armature cover
- Base end shaft
- Return spring

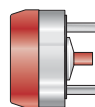

- Armature cover
- Double shaft
- Return spring

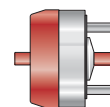

Stroke/ Direction*	Nom. Axial Stroke	Standard		Long Life		Standard		Long Life	
		Standard	Long Life	Standard	Long Life	Standard	Long Life	Standard	Long Life
25° CW	0.6 mm	M-1244-0XX	E-1244-0XX	M-1024-0XX	E-1024-0XX	M-2390-0XX	E-2390-0XX	M-2389-0XX	E-2389-0XX
25° CCW	0.6 mm	M-3259-0XX	E-3259-0XX	M-2452-0XX	E-2452-0XX	M-3405-0XX	E-3405-0XX	M-15111-0XX	E-15111-0XX
35° CW	0.6 mm	M-1294-0XX	E-1294-0XX	M-2116-0XX	E-2116-0XX	M-1344-0XX	E-1344-0XX	M-15046-0XX	E-15046-0XX
35° CCW	0.6 mm	M-1159-0XX	E-1159-0XX	M-15004-0XX	E-15004-0XX	M-2264-0XX	E-2264-0XX	M-2265-0XX	E-2265-0XX
45° CW	0.6 mm	M-2264-0XX	E-2264-0XX	M-2117-0XX	E-2117-0XX	M-2450-0XX	E-2450-0XX	M-15046-0XX	E-15046-0XX
45° CCW	0.6 mm	M-2265-0XX	E-2265-0XX	M-2450-0XX	E-2450-0XX				

\* Direction of rotation (cw – clockwise or ccw – counterclockwise) is viewed from the armature end of the solenoid opposite the mounting studs.

Note: The XX in the part number suffix must be filled in with the awg of your choice.

# Ledex® Rotary Solenoids Size 2E Precision Elongated Coil

## Coil Specifications

Maximum Duty Cycle	100%	50%	25%	10%	5%
Maximum ON Time (sec) when pulsed continuously <sup>1</sup>	∞	100	36	7	2.5
Maximum ON Time (sec) for single pulse <sup>2</sup>	∞	162	44	8	2.8
Watts (@ 20°C)	7	14	28	70	140
Ampere Turns (@ 20°C)	425	602	849	1350	1904

### Coil Data

avg (OXX) <sup>3</sup>	Resistance (@20°C)	# Turns <sup>4</sup>	VDC (Nom)	VDC (Nom)	VDC (Nom)	VDC (Nom)	VDC (Nom)
24	0.68	130	2.2	3.2	4.5	7.1	10.0
25	1.16	174	2.8	4.0	5.7	9.0	12.7
26	1.96	231	3.6	5.1	7.2	11.5	16.2
27	3.16	296	4.5	6.4	9.0	14.4	20.0
28	5.10	378	5.7	8.1	11.5	18.2	26.0
29	6.94	423	7.0	9.9	13.9	22.0	31.0
30	11.03	530	8.8	12.5	17.7	28.0	40.0
31	16.85	649	11.0	15.6	22.0	35.0	49.0
32	28.15	858	13.9	19.8	28.0	44.0	63.0
33	42.75	1036	17.5	25.0	35.0	56.0	79.0
34	69.56	1312	23.0	32.0	45.0	72.0	101.0
35	112.00	1674	29.0	40.0	57.0	91.0	128.0

## General Specifications

Dielectric Strength	1000 VRMS, all coils
Recommended Minimum Heat Sink	Maximum watts dissipated by solenoid are based on an unrestricted flow of air at 20°C, with solenoid mounted on the equivalent of an aluminium plate measuring 84.7 mm square by 3.2 mm thick.
Coil Resistance	±5% tolerance
Starting Torque	Gross torque values are shown. For net starting torque, subtract return spring torque
Return Spring Torque	6.8 mNm ±20%
Weight	56.7 g
Dimensions	See page D29

- <sup>1</sup> Continuously pulsed at stated watts and duty cycle.
- <sup>2</sup> Single pulse at stated watts (with coil at ambient room temperature 20°C).
- <sup>3</sup> Other coil avg sizes available, consult factory.
- <sup>4</sup> Reference number of turns.

All specifications subject to change without notice.

- No shafts
- 3 tapped holes
- Return spring

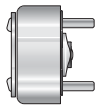

- Armature end shaft
- 3 tapped holes
- Return spring

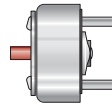

- Base end shaft
- 3 tapped holes
- Return spring

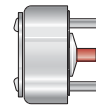

- Double shaft
- 3 tapped holes
- Return spring

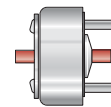

Standard	Long Life	Standard	Long Life	Standard	Long Life	Standard	Long Life
M-2168-OXX	E-2168-OXX	M-1094-OXX	E-1094-OXX	M-2933-OXX	E-2933-OXX	M-2411-OXX	E-2411-OXX
M-2346-OXX	E-2346-OXX	M-2670-OXX	E-2670-OXX	M-2748-OXX	E-2748-OXX	M-2537-OXX	E-2537-OXX
M-2193-OXX	E-2193-OXX	M-2685-OXX	E-2685-OXX	M-1088-OXX	E-1088-OXX	M-2994-OXX	E-2994-OXX
M-2483-OXX	E-2483-OXX	M-15094-OXX	E-15094-OXX	M-15615-OXX	E-15615-OXX	M-15220-OXX	E-15220-OXX
M-1079-OXX	E-1079-OXX	M-2362-OXX	E-2362-OXX	M-3265-OXX	E-3265-OXX	M-3244-OXX	E-3244-OXX
M-2744-OXX	E-2744-OXX	M-3112-OXX	E-3112-OXX	M-2436-OXX	E-2436-OXX	M-3245-OXX	E-3245-OXX

ROTARY Solenoids

# Ledex® Rotary Solenoids Size 3B Bobbin Coil

## Performance Specifications

Stroke	Holding Torque <sup>2</sup> (mNm)	Starting Torque (mNm) <sup>1</sup> @ 20°C Maximum Duty Cycle				
		100%	50%	25%	10%	5%
25°	101.7	45.2	79.1	146.9	305.1	361.6
35°	67.8	33.9	67.8	113.0	226.0	259.9
45°	45.2	22.6	45.2	90.4	158.2	192.1
67½°	45.2	11.3	22.6	45.2	56.5	90.4

All data is at 20°C coil temperature. Force (torque) outputs degrade with elevated temperatures.

<sup>1</sup> Gross starting torques are shown. For net available starting torque, subtract return spring torque of 15.6 mNm ±20%.

<sup>2</sup> Holding torque is shown at the stabilised temperature of 105°C and continuous duty.

\* Consult factory.

ROTARY Solenoids

All catalogue products manufactured after April 1, 2006 are RoHS Compliant

## How to Order

- Using the Performance Chart to the left, select one of the five columns which provides the appropriate duty cycle for your application. Reading down this column locate the torque for the stroke you need. For net available starting torque, subtract return spring torque of 15.6 mNm ±20% (if torque is insufficient go to next larger solenoid size).
- Use the chart below to select the model number corresponding to your desired design, stroke and direction of rotation (as viewed from armature end, opposite mounting studs).
- Using the Specification Chart to the right, select the same duty cycle column. Follow down the column into the VDC ratings. Select the voltage which most closely matches your supply voltage. Read across to the left to select the coil awg suffix.
- Replace the last two digits of the model number (XX) with the coil awg number to complete the part number.

Please see [www.ledex.com](http://www.ledex.com) (click on Stock Products tab) for our list of stock products available through our distributors.

- Armature cover
- Base end shaft
- Return spring

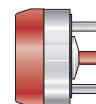

Stroke/ Direction*	Nom. Axial Stroke	
25° CW	0.8 mm	910-380-3XX
25° CCW	0.8 mm	910-385-3XX
35° CW	0.8 mm	910-381-3XX
35° CCW	0.8 mm	910-386-3XX
45° CW	0.8 mm	910-382-3XX
45° CCW	0.8 mm	910-387-3XX
67½° CW	0.8 mm	910-383-3XX
67½° CCW	0.8 mm	910-388-3XX

\* Direction of rotation (cw – clockwise or ccw – counterclockwise) is viewed from the armature end of the solenoid opposite the mounting studs.

Note: The XX in the part number suffix must be filled in with the awg of your choice.

# Ledex® Rotary Solenoids Size 3B Bobbin Coil

## Coil Specifications

Maximum Duty Cycle	100%	50%	25%	10%	5%
Maximum ON Time (sec) when pulsed continuously <sup>1</sup>	∞	100	36	8	2.8
Maximum ON Time (sec) for single pulse <sup>2</sup>	∞	162	44	9	3.2
Watts (@ 20°C)	10	20	40	100	200
Ampere Turns (@ 20°C)	550	785	1100	1740	2464

### Coil Data

awg (0XX) <sup>3</sup>	Resistance (@20°C)	# Turns <sup>4</sup>	VDC (Nom)	VDC (Nom)	VDC (Nom)	VDC (Nom)	VDC (Nom)
23	0.65	136	2.6	3.7	5.2	8.3	11.8
24	1.13	188	3.3	4.7	6.6	10.5	14.8
25	1.86	238	4.3	6.1	8.6	13.6	19.3
26	2.95	300	5.4	7.7	10.8	17.1	24.0
27	4.67	377	6.8	9.7	13.6	22.0	31.0
28	7.40	466	8.7	12.5	17.5	28.0	39.0
29	11.46	576	10.9	15.6	22.0	35.0	49.0
30	18.40	720	14.1	20.0	28.0	45.0	63.0
31	29.60	960	17.0	24.0	34.0	54.0	76.0
32	45.60	1157	22.0	31.0	43.0	69.0	97.0
33	73.20	1470	28.0	39.0	55.0	87.0	123.0

## General Specifications

Dielectric Strength	23-27 awg, 1000 VRMS; 28-33 awg, 1200 VRMS
Recommended Minimum Heat Sink	Maximum watts dissipated by solenoid are based on an unrestricted flow of air at 20°C, with solenoid mounted on the equivalent of an aluminium plate measuring 85.7 mm square by 3.2 mm thick.
Coil Resistance	±10% tolerance
Starting Torque	Gross torque values are shown. For net starting torque, subtract return spring torque
Weight	113.4 g
Return Spring Torque	13.6 mNm ±20%
Dimensions	See page D30

- <sup>1</sup> Continuously pulsed at stated watts and duty cycle.
- <sup>2</sup> Single pulse at stated watts (with coil at ambient room temperature 20°C).
- <sup>3</sup> Other coil awg sizes available, consult factory.
- <sup>4</sup> Reference number of turns.

All specifications subject to change without notice.

- No shafts
- 3 tapped holes
- Return spring

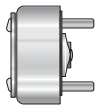

910-640-3XX  
910-645-3XX  
910-641-3XX  
910-646-3XX  
910-642-3XX  
910-647-3XX  
910-643-3XX  
910-648-3XX

- Armature end shaft
- 3 tapped holes
- Return spring

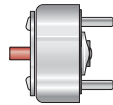

910-490-3XX  
910-495-3XX  
910-491-3XX  
910-496-3XX  
910-492-3XX  
910-497-3XX  
910-493-3XX  
910-498-3XX

- Base end shaft
- 3 tapped holes
- Return spring

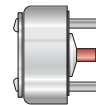

910-360-3XX  
910-365-3XX  
910-361-3XX  
910-366-3XX  
910-362-3XX  
910-367-3XX  
910-363-3XX  
910-368-3XX

- Double shaft
- 3 tapped holes
- Return spring

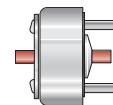

910-280-3XX  
910-285-3XX  
910-281-3XX  
910-286-3XX  
910-282-3XX  
910-287-3XX  
910-283-3XX  
910-288-3XX

# Ledex® Rotary Solenoids Size 3E Precision Elongated Coil

## Performance Specifications

Stroke	Holding Torque <sup>2</sup> (mNm)	Starting Torque (mNm) <sup>1</sup> @ 20°C Maximum Duty Cycle				
		100%	50%	25%	10%	5%
25°	101.7	45.2	90.4	158.2	305.1	361.6
35°	79.1	33.9	67.8	113.0	226.0	259.9
45°	67.8	22.6	45.2	90.4	158.2	203.4
67½°	56.5	11.3	22.6	45.2	79.1	101.7

All data is at 20°C coil temperature. Force (torque) outputs degrade with elevated temperatures.

- <sup>1</sup> Gross starting torques are shown. For net available starting torque, subtract return spring torque of 13.6 mNm ±20%.
- <sup>2</sup> Holding torque is shown at the stabilised temperature of 105°C and continuous duty.
- \* Consult factory.

ROTARY Solenoids

## How to Order

1. Using the Performance Chart to the left, select one of the five columns which provides the appropriate duty cycle for your application. Reading down this column locate the torque for the stroke you need. For net available starting torque, subtract return spring torque of 13.6 mNm ±20% (if torque is insufficient go to next larger solenoid size).
2. Use the chart below to select the model number corresponding to your desired design, stroke and direction of rotation (as viewed from armature end, opposite mounting studs).
3. Using the Specification Chart to the right, select the same duty cycle column. Follow down the column into the VDC ratings. Select the voltage which most closely matches your supply voltage. Read across to the left to select the coil awg suffix.
4. Replace the last two digits of the model number (XX) with the coil awg number to complete the part number.

Please see [www.ledex.com](http://www.ledex.com) (click on Stock Products tab) for our list of stock products available through our distributors.

All catalogue products manufactured after April 1, 2006 are RoHS Compliant

- Armature cover
- Armature end shaft
- Return spring

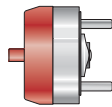

- Armature cover
- Base end shaft
- Return spring

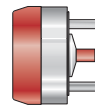

- Armature cover
- Double shaft
- Return spring

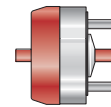

Stroke/ Direction*	Nom. Axial Stroke	Standard		Long Life		Standard		Long Life	
		Standard	Long Life	Standard	Long Life	Standard	Long Life		
25° CW	0.8 mm	M-2437-0XX	E-2437-0XX	M-2126-0XX	E-2126-0XX	M-15080-0XX	E-15080-0XX	M-3374-0XX	E-3374-0XX
25° CCW	0.8 mm	M-1245-0XX	E-1245-0XX	M-2276-0XX	E-2276-0XX	M-3401-0XX	E-3401-0XX	M-15005-0XX	E-15005-0XX
35° CW	0.8 mm	M-2562-0XX	E-2562-0XX	M-2127-0XX	E-2127-0XX	M-2711-0XX	E-2711-0XX	M-2419-0XX	E-2419-0XX
35° CCW	0.8 mm	M-3398-0XX	E-3398-0XX	M-2209-0XX	E-2209-0XX	M-2008-0XX	E-2008-0XX	M-2453-0XX	E-2453-0XX
45° CW	0.8 mm	M-2259-0XX	E-2259-0XX	M-2008-0XX	E-2008-0XX	M-2711-0XX	E-2711-0XX	M-2712-0XX	E-2712-0XX
45° CCW	0.8 mm	M-2419-0XX	E-2419-0XX	M-2453-0XX	E-2453-0XX	M-15040-0XX	—	M-15107-0XX	—
67½° CW	0.8 mm	M-3278-0XX	—	M-2128-0XX	—	—	—	—	—
67½° CCW	0.8 mm	M-3279-0XX	—	M-3004-0XX	—	—	—	—	—

\* Direction of rotation (cw – clockwise or ccw – counterclockwise) is viewed from the armature end of the solenoid opposite the mounting studs.

Note: The XX in the part number suffix must be filled in with the awg of your choice.

# Ledex® Rotary Solenoids Size 3E Precision Elongated Coil

## Coil Specifications

Maximum Duty Cycle	100%	50%	25%	10%	5%
Maximum ON Time (sec) when pulsed continuously <sup>1</sup>	∞	100	36	8	2.8
Maximum ON Time (sec) for single pulse <sup>2</sup>	∞	162	44	9	3.2
Watts (@ 20°C)	9	18	36	90	180
Ampere Turns (@ 20°C)	535	756	1070	1690	2397

### Coil Data

awg (0XX) <sup>3</sup>	Resistance (@20°C)	# Turns <sup>4</sup>	VDC (Nom)	VDC (Nom)	VDC (Nom)	VDC (Nom)	VDC (Nom)
23	0.70	145	2.6	3.7	5.2	8.2	11.6
24	1.18	192	3.3	4.6	6.6	10.4	14.7
25	1.97	252	4.2	5.9	8.4	13.2	18.7
26	3.26	328	5.3	7.5	10.6	16.8	24.0
27	5.04	405	6.7	9.4	13.3	21.0	30.0
28	8.02	510	8.4	11.9	16.8	27.0	38.0
29	12.21	627	10.4	14.7	21.0	33.0	47.0
30	19.20	780	13.2	18.6	26.0	42.0	59.0
31	31.84	1008	16.9	24.0	34.0	53.0	76.0
32	46.97	1215	21.0	29.0	41.0	65.0	93.0
33	75.30	1530	26.0	37.0	53.0	83.0	118.0

## General Specifications

Dielectric Strength	23-27 awg, 1000 VRMS; 28-33 awg, 1200 VRMS
Recommended Minimum Heat Sink	Maximum watts dissipated by solenoid are based on an unrestricted flow of air at 20°C, with solenoid mounted on the equivalent of an aluminium plate measuring 117.5 mm square by 3.2 thick.
Coil Resistance	±5% tolerance
Starting Torque	Gross torque values are shown. For net starting torque, subtract return spring torque
Return Spring Torque	13.6 mNm ±20%
Weight	99.2 g
Dimensions	See page D31

- <sup>1</sup> Continuously pulsed at stated watts and duty cycle.
- <sup>2</sup> Single pulse at stated watts (with coil at ambient room temperature 20°C).
- <sup>3</sup> Other coil awg sizes available, consult factory.
- <sup>4</sup> Reference number of turns.

ROTARY Solenoids

All specifications subject to change without notice.

- No shafts
- 3 tapped holes
- Return spring

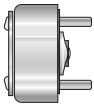

- Armature end shaft
- 3 tapped holes
- Return spring

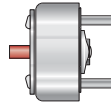

- Base end shaft
- 3 tapped holes
- Return spring

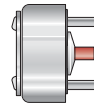

- Double shaft
- 3 tapped holes
- Return spring

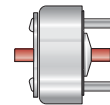

Standard		Long Life		Standard		Long Life		Standard		Long Life	
M-1075-0XX	E-1075-0XX	M-2512-0XX	E-2512-0XX	M-3169-0XX	E-3169-0XX	M-2412-0XX	E-2412-0XX	M-15128-0XX	E-15128-0XX		
M-2159-0XX	E-2159-0XX	M-2992-0XX	E-2992-0XX	M-2978-0XX	E-2978-0XX	M-2722-0XX	E-2722-0XX	M-2723-0XX	E-2723-0XX		
M-2216-0XX	E-2216-0XX	M-2634-0XX	E-2634-0XX	M-2330-0XX	E-2330-0XX	M-2616-0XX	E-2616-0XX	M-15020-0XX	E-15020-0XX		
M-2444-0XX	E-2444-0XX	M-3044-0XX	E-3044-0XX	M-15221-0XX	E-152221-0XX	M-2289-0XX	—	M-2542-0XX	—		
M-2556-0XX	E-2556-0XX	M-3045-0XX	E-3045-0XX	M-1135-0XX	E-1135-0XX	M-2288-0XX	—	M-2940-0XX	—		
M-2268-0XX	E-2268-0XX	M-2906-0XX	E-2906-0XX	M-2613-0XX	E-2613-0XX						
		M-2550-0XX	—	M-15071-0XX	—						
		M-1330-0XX	—	M-3381-0XX	—						

# Ledex® Rotary Solenoids Size 4E Precision Elongated Coil

## Performance Specifications

Stroke	Holding Torque <sup>2</sup> (mNm)	Starting Torque (mNm) <sup>1</sup> @ 20°C Maximum Duty Cycle				
		100%	50%	25%	10%	5%
25°	226.0	101.7	192.1	350.3	508.5	587.6
35°	*	67.8	124.3	226.0	350.3	395.5
45°	113.0	45.2	101.7	180.8	293.8	350.3
55°	*	*	*	*	*	*
67½°	*	22.6	45.2	90.4	180.8	214.7
95°	101.7	22.6	33.9	67.8	113.0	135.6

All data is at 20°C coil temperature. Force (torque) outputs degrade with elevated temperatures.

- <sup>1</sup> Gross starting torques are shown. For net available starting torque, subtract return spring torque of 20.3 mNm ±20%.
- <sup>2</sup> Holding torque is shown at the stabilised temperature of 105°C and continuous duty.
- \* Consult factory.

## How to Order

- Using the Performance Chart to the left, select one of the five columns which provides the appropriate duty cycle for your application. Reading down this column locate the torque for the stroke you need. For net available starting torque, subtract return spring torque of 20.3 mNm ±20% (if torque is insufficient go to next larger solenoid size).
- Use the chart below to select the model number corresponding to your desired design, stroke and direction of rotation (as viewed from armature end, opposite mounting studs).
- Using the Specification Chart to the right, select the same duty cycle column. Follow down the column into the VDC ratings. Select the voltage which most closely matches your supply voltage. Read across to the left to select the coil awg suffix.
- Replace the last two digits of the model number (XX) with the coil awg number to complete the part number.

Please see [www.ledex.com](http://www.ledex.com) (click on Stock Products tab) for our list of stock products available through our distributors.

All catalogue products manufactured after April 1, 2006 are RoHS Compliant

- Armature cover
- Armature end shaft
- Return spring

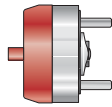

- Armature cover
- Base end shaft
- Return spring

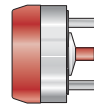

- Armature cover
- Double shaft
- Return spring

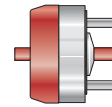

Stroke/ Direction*	Nom. Axial Stroke	Standard		Long Life		Standard		Long Life	
		Standard	Long Life	Standard	Long Life	Standard	Long Life		
25° CW	0.9 mm	M-3271-0XX	E-3271-0XX	M-3108-0XX	E-3108-0XX	M-15000-0XX	E-15000-0XX		
25° CCW	0.9 mm	M-3258-0XX	E-3258-0XX	M-2975-0XX	E-2975-0XX	M-15001-0XX	E-15001-0XX		
35° CW	0.9 mm	M-15011-0XX	E-15011-0XX	M-1132-0XX	E-1132-0XX	M-3378-0XX	E-3378-0XX		
35° CCW	0.9 mm	M-15015-0XX	E-15015-0XX	M-1258-0XX	E-1258-0XX	M-3379-0XX	E-3379-0XX		
45° CW	0.9 mm	M-1246-0XX	E-1246-0XX	M-3126-0XX	E-3126-0XX	M-2980-0XX	E-2980-0XX		
45° CCW	0.9 mm	M-1247-0XX	E-1247-0XX	M-2900-0XX	E-2900-0XX	M-2893-0XX	E-2893-0XX		
55° CW	0.9 mm	M-15222-0XX	—	M-15223-0XX	—	M-15224-0XX	—		
67½° CW	1.1 mm	M-15091-0XX	—	M-3074-0XX	—	M-3425-0XX	—		
67½° CCW	1.1 mm	M-1435-0XX	—	M-1521-0XX	—	M-15122-0XX	—		
95° CW	1.1 mm	M-1218-0XX	—	M-3117-0XX	—	M-3084-0XX	—		
95° CCW	1.1 mm	M-2563-0XX	—	M-2640-0XX	—	M-15127-0XX	—		

\* Direction of rotation (cw – clockwise or ccw – counterclockwise) is viewed from the armature end of the solenoid opposite the mounting studs.

Note: The XX in the part number suffix must be filled in with the awg of your choice.

# Ledex® Rotary Solenoids Size 4E Precision Elongated Coil

## Coil Specifications

Maximum Duty Cycle	100%	50%	25%	10%	5%		
Maximum ON Time (sec) when pulsed continuously <sup>1</sup>	∞	100	36	9	3.2		
Maximum ON Time (sec) for single pulse <sup>2</sup>	∞	162	44	10	3.5		
Watts (@ 20°C)	12.5	25	50	125	250		
Ampere Turns (@ 20°C)	714	1000	1425	2250	3200		
Coil Data							
awg (OXX) <sup>3</sup>	Resistance (@20°C)	# Turns <sup>4</sup>	VDC (Nom)	VDC (Nom)	VDC (Nom)	VDC (Nom)	VDC (Nom)
23	1.59	266	4.3	6.0	8.5	13.4	19.1
24	2.20	301	5.2	7.3	10.4	16.4	24.0
25	3.54	384	6.6	9.2	13.1	21.0	30.0
26	5.67	486	8.3	11.7	16.6	26.0	37.0
27	8.76	600	10.4	14.6	21.0	33.0	47.0
28	13.80	748	13.2	18.5	26.0	42.0	59.0
29	22.60	975	16.6	23.0	33.0	52.0	74.0
30	34.80	1190	21.0	29.0	42.0	66.0	94.0
31	56.70	1520	27.0	37.0	53.0	84.0	119.0
32	88.30	1908	33.0	46.0	66.0	104.0	148.0
33	138.00	2360	42.0	59.0	83.0	132.0	187.0

## General Specifications

Dielectric Strength	23-24 awg, 1000 VRMS; 25-33 awg, 1200 VRMS
Recommended Minimum Heat Sink	Maximum watts dissipated by solenoid are based on an unrestricted flow of air at 20°C, with solenoid mounted on the equivalent of an aluminium plate measuring 158.8 mm square by 3.2 mm thick.
Coil Resistance	±5% tolerance
Starting Torque	Gross torque values are shown. For net starting torque, subtract return spring torque
Return Spring Torque	20.3 mNm ±20%
Weight	198.4 g
Dimensions	See page D32

- Continuously pulsed at stated watts and duty cycle.
- Single pulse at stated watts (with coil at ambient room temperature 20°C).
- Other coil awg sizes available, consult factory.
- Reference number of turns.

ROTARY Solenoids

All specifications subject to change without notice.

- No shafts
- 3 tapped holes
- Return spring

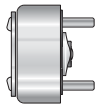

- Armature end shaft
- 3 tapped holes
- Return spring

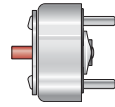

- Base end shaft
- 3 tapped holes
- Return spring

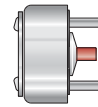

- Double shaft
- 3 tapped holes
- Return spring

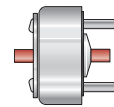

Standard	Long Life	Standard	Long Life	Standard	Long Life	Standard	Long Life
M-2650-OXX	E-2650-OXX	M-3324-OXX	E-3324-OXX	M-1174-OXX	E-1174-OXX	M-2413-OXX	E-2413-OXX
M-2741-OXX	E-2741-OXX	M-15120-OXX	E-15120-OXX	M-15125-OXX	E-15125-OXX	M-15135-OXX	E-15135-OXX
M-2952-OXX	E-2952-OXX	M-15016-OXX	E-15016-OXX	M-15230-OXX	E-15230-OXX	M-2995-OXX	E-2995-OXX
M-3352-OXX	E-3352-OXX	M-15229-OXX	E-15229-OXX	M-15231-OXX	E-15231-OXX	M-15236-OXX	E-15236-OXX
M-1168-OXX	E-1168-OXX	M-3071-OXX	E-3071-OXX	M-1310-OXX	E-1310-OXX	M-15237-OXX	E-15237-OXX
M-1226-OXX	E-1226-OXX	M-3125-OXX	E-3125-OXX	M-1309-OXX	E-1309-OXX	M-15238-OXX	E-15238-OXX
M-15225-OXX	—	M-15226-OXX	—	M-15227-OXX	—	M-15228-OXX	—
M-2310-OXX	—	M-3402-OXX	—	M-15233-OXX	—	M-15021-OXX	—
M-2967-OXX	—	M-15232-OXX	—	M-15234-OXX	—	M-15239-OXX	—
M-2862-OXX	—	M-2929-OXX	—	M-2626-OXX	—	M-2645-OXX	—
M-1263-OXX	—	M-2930-OXX	—	M-15235-OXX	—	M-1115-OXX	—

# Ledex® Rotary Solenoids Size 5B Bobbin Coil

## Performance Specifications

Stroke	Holding Torque <sup>2</sup> (mNm)	Starting Torque (mNm) <sup>1</sup> @ 20°C Maximum Duty Cycle				
		100%	50%	25%	10%	5%
25°	452.0	203.4	395.5	655.4	937.9	1130.0
35°	**	101.7	237.3	463.3	779.7	937.9
45°	339.0	79.1	192.1	361.6	565.0	678.0
67½°	*	56.5	124.3	226.0	372.9	452.0
95°	226.0	22.6	45.2	101.7	180.8	214.7

All data is at 20°C coil temperature. Force (torque) outputs degrade with elevated temperatures.

<sup>1</sup> Gross starting torques are shown. For net available starting torque, subtract return spring torque of 28.2 mNm ±20%.

<sup>2</sup> Holding torque is shown at the stabilised temperature of 105°C and continuous duty.

\* Consult factory.

## How to Order

- Using the Performance Chart to the left, select one of the five columns which provides the appropriate duty cycle for your application. Reading down this column locate the torque for the stroke you need. For net available starting torque, subtract return spring torque of 28.2 mNm ±20% (if torque is insufficient go to next larger solenoid size).
- Use the chart below to select the model number corresponding to your desired design, stroke and direction of rotation (as viewed from armature end, opposite mounting studs).
- Using the Specification Chart to the right, select the same duty cycle column. Follow down the column into the VDC ratings. Select the voltage which most closely matches your supply voltage. Read across to the left to select the coil awg suffix.
- Replace the last two digits of the model number (XX) with the coil awg number to complete the part number.

Please see [www.ledex.com](http://www.ledex.com) (click on Stock Products tab) for our list of stock products available through our distributors.

All catalogue products manufactured after April 1, 2006 are RoHS Compliant

ROTARY Solenoids

- Armature cover
- Base end shaft
- Return spring

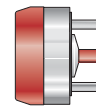

Stroke/ Direction*	Nom. Axial Stroke	
25° CW	1.1 mm	910-380-5XX
25° CCW	1.1 mm	910-385-5XX
35° CW	1.1 mm	910-381-5XX
35° CCW	1.1 mm	910-386-5XX
45° CW	1.1 mm	910-382-5XX
45° CCW	1.1 mm	910-387-5XX
67½° CW	1.3 mm	910-383-5XX
67½° CCW	1.3 mm	910-388-5XX
95° CW	1.4 mm	910-384-5XX
95° CCW	1.4 mm	910-389-5XX

\* Direction of rotation (cw – clockwise or ccw – counterclockwise) is viewed from the armature end of the solenoid opposite the mounting studs.

Note: The XX in the part number suffix must be filled in with the awg of your choice.

# Ledex® Rotary Solenoids Size 5B Bobbin Coil

## Coil Specifications

Maximum Duty Cycle	100%	50%	25%	10%	5%
Maximum ON Time (sec) when pulsed continuously <sup>1</sup>	∞	100	36	10	3.5
Maximum ON Time (sec) for single pulse <sup>2</sup>	∞	160	44	13	4.6
Watts (@ 20°C)	21	42	84	210	420
Ampere Turns (@ 20°C)	890	1250	1760	2800	3987

### Coil Data

awg (0XX) <sup>3</sup>	Resistance (@20°C)	# Turns <sup>4</sup>	VDC (Nom)	VDC (Nom)	VDC (Nom)	VDC (Nom)	VDC (Nom)
23	2.01	294	6.1	8.5	12.0	19.1	27.0
24	3.15	364	7.7	10.8	15.2	24.0	35.0
25	4.88	448	9.7	13.6	19.2	31.0	43.0
26	7.72	564	12.2	17.1	24.0	38.0	55.0
27	10.90	648	15.0	21.0	30.0	47.0	67.0
28	18.20	836	19.4	27.0	38.0	61.0	87.0
29	30.40	1105	25.0	34.0	48.0	77.0	110.0
30	42.50	1248	30.0	43.0	60.0	95.0	136.0
31	69.00	1590	39.0	54.0	76.0	122.0	173.0
32	107.00	2006	48.0	67.0	94.0	149.0	213.0
33	169.00	2470	61.0	86.0	120.0	192.0	273.0

## General Specifications

Dielectric Strength	23 awg, 1000 VRMS; 24-33 awg, 1200 VRMS
Recommended Minimum Heat Sink	Maximum watts dissipated by solenoid are based on an unrestricted flow of air at 20°C, with solenoid mounted on the equivalent of an aluminium plate measuring 90.5 mm square by 3.2 mm thick.
Coil Resistance	±10% tolerance
Starting Torque	Gross torque values are shown. For net starting torque, subtract return spring torque
Return Spring Torque	28.2 mNm ±20%
Weight	283.5 g
Dimensions	See page D33

- Continuously pulsed at stated watts and duty cycle.
- Single pulse at stated watts (with coil at ambient room temperature 20°C).
- Other coil awg sizes available, consult factory.
- Reference number of turns.

All specifications subject to change without notice.

- No shafts
- 3 tapped holes
- Return spring

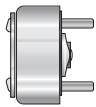

- Armature end shaft
- 3 tapped holes
- Return spring

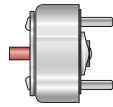

- Base end shaft
- 3 tapped holes
- Return spring

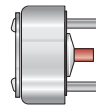

- Double shaft
- 3 tapped holes
- Return spring

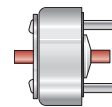

910-640-5XX  
910-645-5XX

910-490-5XX  
910-495-5XX

910-360-5XX  
910-365-5XX

910-280-5XX  
910-285-5XX

910-641-5XX  
910-646-5XX

910-491-5XX  
910-496-5XX

910-361-5XX  
910-366-5XX

910-281-5XX  
910-286-5XX

910-642-5XX  
910-647-5XX

910-492-5XX  
910-497-5XX

910-362-5XX  
910-367-5XX

910-282-5XX  
910-287-5XX

910-643-5XX  
910-648-5XX

910-493-5XX  
910-498-5XX

910-363-5XX  
910-368-5XX

910-283-5XX  
910-288-5XX

910-644-5XX  
910-649-5XX

910-494-5XX  
910-499-5XX

910-364-5XX  
910-369-5XX

910-284-5XX  
910-289-5XX

# Ledex® Rotary Solenoids Size 5S Precision Standard Coil

## Performance Specifications

Stroke	Holding Torque <sup>2</sup> (mNm)	Starting Torque (mNm) <sup>1</sup> @ 20°C Maximum Duty Cycle				
		100%	50%	25%	10%	5%
25°	565.5	214.7	463.3	824.9	1367.3	1491.6
35°	*	135.6	293.8	508.5	881.4	1039.6
45°	339.0	79.1	192.1	384.2	711.9	779.7
55°	*	*	*	*	*	*
67½°	*	56.5	135.6	248.6	440.7	553.7
75°	*	*	*	*	*	*
95°	226.0	22.6	56.5	113.0	214.7	293.8
110°	*	*	*	*	*	*

All data is at 20°C coil temperature. Force (torque) outputs degrade with elevated temperatures.

- <sup>1</sup> Gross starting torques are shown. For net available starting torque, subtract return spring torque of 28.2 mNm ±20%.
- <sup>2</sup> Holding torque is shown at the stabilised temperature of 105°C and continuous duty.
- \* Consult factory.

## How to Order

- Using the Performance Chart to the left, select one of the five columns which provides the appropriate duty cycle for your application. Reading down this column locate the torque for the stroke you need. For net available starting torque, subtract return spring torque of 28.2 mNm ±20% (if torque is insufficient go to next larger solenoid size).
- Use the chart below to select the model number corresponding to your desired design, stroke and direction of rotation (as viewed from armature end, opposite mounting studs).
- Using the Specification Chart to the right, select the same duty cycle column. Follow down the column into the VDC ratings. Select the voltage which most closely matches your supply voltage. Read across to the left to select the coil awg suffix.
- Replace the last two digits of the model number (XX) with the coil awg number to complete the part number.

Please see [www.ledex.com](http://www.ledex.com) (click on Stock Products tab) for our list of stock products available through our distributors.

All catalogue products manufactured after April 1, 2006 are RoHS Compliant

- Armature cover
- Armature end shaft
- Return spring

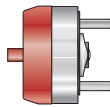

- Armature cover
- Base end shaft
- Return spring

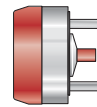

- Armature cover
- Double shaft
- Return spring

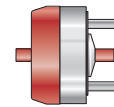

Stroke/ Direction*	Nom. Axial Stroke	Standard		Long Life		Standard		Long Life	
		Standard	Long Life	Standard	Long Life	Standard	Long Life		
25° CW	1.1 mm	M-2480-0XX	E-2480-0XX	M-2073-0XX	E-2073-0XX	M-15165-0XX	E-15165-0XX		
25° CCW	1.1 mm	M-2657-0XX	E-2657-0XX	M-2593-0XX	E-2593-0XX	M-3421-0XX	E-3421-0XX		
35° CW	1.1 mm	M-2658-0XX	E-2658-0XX	M-2681-0XX	E-2681-0XX	M-2874-0XX	E-2874-0XX		
35° CCW	1.1 mm	M-3384-0XX	E-3384-0XX	M-2479-0XX	E-2479-0XX	M-1423-0XX	E-1423-0XX		
45° CW	1.1 mm	M-2527-0XX	E-2527-0XX	M-2383-0XX	E-2383-0XX	M-1345-0XX	E-1345-0XX		
45° CCW	1.1 mm	M-1125-0XX	E-1125-0XX	M-2300-0XX	E-2300-0XX	M-15072-0XX	E-15072-0XX		
55° CW	1.2 mm	M-15305-0XX	—	M-15310-0XX	—	M-15315-0XX	—		
55° CCW	1.2 mm	M-15306-0XX	—	M-15311-0XX	—	M-15316-0XX	—		
67½° CW	1.3 mm	M-1390-0XX	—	M-2349-0XX	—	M-3375-0XX	—		
67½° CCW	1.3 mm	M-3385-0XX	—	M-2262-0XX	—	M-3377-0XX	—		
75° CCW	1.3 mm	M-15307-0XX	—	M-15312-0XX	—	M-15317-0XX	—		
95° CW	1.4 mm	M-2010-0XX	—	M-2382-0XX	—	M-15150-0XX	—		
95° CCW	1.4 mm	M-1248-0XX	—	M-2747-0XX	—	M-15131-0XX	—		
110° CW	1.4 mm	M-15308-0XX	—	M-15313-0XX	—	M-15318-0XX	—		
110° CCW	1.4 mm	M-15309-0XX	—	M-15314-0XX	—	M-15319-0XX	—		

\* Direction of rotation (cw – clockwise or ccw – counterclockwise) is viewed from the armature end of the solenoid opposite the mounting studs.

Note: The XX in the part number suffix must be filled in with the awg of your choice.

# Ledex® Rotary Solenoids Size 5S Precision Standard Coil

## Coil Specifications

Maximum Duty Cycle	100%	50%	25%	10%	5%
Maximum ON Time (sec) when pulsed continuously <sup>1</sup>	∞	100	36	10	3.5
Maximum ON Time (sec) for single pulse <sup>2</sup>	∞	160	44	13	4.6
Watts (@ 20°C)	21	42	84	210	420
Ampere Turns (@ 20°C)	860	1220	1720	2730	3853

### Coil Data

awg (OXX) <sup>3</sup>	Resistance (@20°C)	# Turns <sup>4</sup>	VDC (Nom)	VDC (Nom)	VDC (Nom)	VDC (Nom)	VDC (Nom)
23	2.03	288	6.1	8.6	12.1	19.2	27.0
24	3.20	360	7.6	10.8	15.3	24.0	34.0
25	4.91	440	9.6	13.6	19.2	31.0	43.0
26	7.72	550	12.1	17.1	24.0	38.0	54.0
27	11.12	636	15.0	21.0	30.0	48.0	67.0
28	18.79	840	19.2	27.0	39.0	61.0	86.0
29	30.48	1088	24.0	34.0	48.0	77.0	108.0
30	44.86	1275	30.0	43.0	61.0	96.0	136.0
31	70.90	1596	38.0	54.0	76.0	121.0	171.0
32	109.00	1974	47.0	67.0	95.0	150.0	212.0
33	175.00	2496	60.0	86.0	121.0	192.0	271.0

## General Specifications

Dielectric Strength	23 awg, 1000 VRMS; 24-33 awg, 1200 VRMS
Recommended Minimum Heat Sink	Maximum watts dissipated by solenoid are based on an unrestricted flow of air at 20°C, with solenoid mounted on the equivalent of an aluminium plate measuring 190.5 mm square by 3.2 thick.
Coil Resistance	±5% tolerance
Starting Torque	Gross torque values are shown. For net starting torque, subtract return spring torque
Return Spring Torque	28.2 mNm ±20%
Weight	255.2 g
Dimensions	See page D34

- Continuously pulsed at stated watts and duty cycle.
- Single pulse at stated watts (with coil at ambient room temperature 20°C).
- Other coil awg sizes available, consult factory.
- Reference number of turns.

All specifications subject to change without notice.

- No shafts
- 3 tapped holes
- Return spring

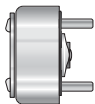

- Armature end shaft
- 3 tapped holes
- Return spring

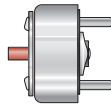

- Base end shaft
- 3 tapped holes
- Return spring

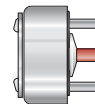

- Double shaft
- 3 tapped holes
- Return spring

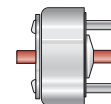

Standard	Long Life	Standard	Long Life	Standard	Long Life	Standard	Long Life
M-1082-OXX	E-1082-OXX	M-2668-OXX	E-2668-OXX	M-2050-OXX	E-2050-OXX	M-2414-OXX	E-2414-OXX
M-2434-OXX	E-2434-OXX	M-2669-OXX	E-2669-OXX	M-3189-OXX	E-3189-OXX	M-2708-OXX	E-2708-OXX
M-2560-OXX	E-2560-OXX	M-3151-OXX	E-3151-OXX	M-2186-OXX	E-2186-OXX	M-2875-OXX	E-2875-OXX
M-1087-OXX	E-1087-OXX	M-1431-OXX	E-1431-OXX	M-3276-OXX	E-3276-OXX	M-2016-OXX	E-2016-OXX
M-2397-OXX	E-2397-OXX	M-2555-OXX	E-2555-OXX	M-2136-OXX	E-2136-OXX	M-3397-OXX	E-3397-OXX
M-2185-OXX	E-2185-OXX	M-3238-OXX	E-3238-OXX	M-1308-OXX	E-1308-OXX	M-2845-OXX	E-2845-OXX
M-15320-OXX	—	M-15325-OXX	—	M-15330-OXX	—	M-15335-OXX	—
M-15321-OXX	—	M-15326-OXX	—	M-15331-OXX	—	M-15336-OXX	—
M-2522-OXX	—	M-2075-OXX	—	M-1020-OXX	—	M-3399-OXX	—
M-2902-OXX	—	M-3249-OXX	—	M-15055-OXX	—	M-3400-OXX	—
M-15322-OXX	—	M-15327-OXX	—	M-15332-OXX	—	M-15337-OXX	—
M-2714-OXX	—	M-2074-OXX	—	M-2957-OXX	—	M-1155-OXX	—
M-2296-OXX	—	M-2150-OXX	—	M-1307-OXX	—	M-1154-OXX	—
M-15323-OXX	—	M-15328-OXX	—	M-15333-OXX	—	M-15338-OXX	—
M-15324-OXX	—	M-15329-OXX	—	M-15334-OXX	—	M-15339-OXX	—

# Ledex® Rotary Solenoids Size 6S Precision Standard Coil

## Performance Specifications

Stroke	Holding Torque <sup>2</sup> (mNm)	Starting Torque (mNm) <sup>1</sup> @ 20°C Maximum Duty Cycle				
		100%	50%	25%	10%	5%
25°	1017.0	519.8	1005.7	1830.6	3141.4	3457.8
35°	*	384.2	734.5	1356.0	2101.8	2316.5
45°	678.0	192.1	395.5	734.5	1243.0	1367.31
55°	*	*	*	*	*	*
67½°	*	180.8	350.3	632.8	994.4	1096.1
95°	339.0	101.7	192.1	372.9	587.6	644.1
110°	*	*	*	*	*	*

All data is at 20°C coil temperature. Force (torque) outputs degrade with elevated temperatures.

<sup>1</sup> Gross starting torques are shown. For net available starting torque, subtract return spring torque of 56.5 mNm ±20%.

<sup>2</sup> Holding torque is shown at the stabilised temperature of 105°C and continuous duty.

\* Consult factory.

## How to Order

- Using the Performance Chart to the left, select one of the five columns which provides the appropriate duty cycle for your application. Reading down this column locate the torque for the stroke you need. For net available starting torque, subtract return spring torque of 56.5 mNm ±20% (if torque is insufficient go to next larger solenoid size).
- Use the chart below to select the model number corresponding to your desired design, stroke and direction of rotation (as viewed from armature end, opposite mounting studs).
- Using the Specification Chart to the right, select the same duty cycle column. Follow down the column into the VDC ratings. Select the voltage which most closely matches your supply voltage. Read across to the left to select the coil awg suffix.
- Replace the last two digits of the model number (XX) with the coil awg number to complete the part number.

Please see [www.ledex.com](http://www.ledex.com) (click on Stock Products tab) for our list of stock products available through our distributors.

All catalogue products manufactured after April 1, 2006 are RoHS Compliant

- Armature cover
- Armature end shaft
- Return spring

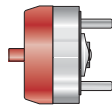

- Armature cover
- Base end shaft
- Return spring

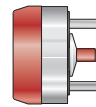

- Armature cover
- Double shaft
- Return spring

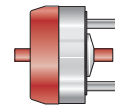

Stroke/ Direction*	Nom. Axial Stroke	Standard		Long Life		Standard		Long Life	
		Standard	Long Life	Standard	Long Life	Standard	Long Life		
25° CW	1.4 mm	M-1202-0XX	E-1202-0XX	M-2484-0XX	E-2484-0XX	M-3376-0XX	E-3376-0XX	M-15036-0XX	E-15036-0XX
25° CCW	1.4 mm	M-1005-0XX	E-1005-0XX	M-2485-0XX	E-2485-0XX	M-15036-0XX	E-15036-0XX	M-15036-0XX	E-15036-0XX
35° CW	1.5 mm	M-15023-0XX	E-15023-0XX	M-2916-0XX	E-2916-0XX	M-3365-0XX	E-3365-0XX	M-2964-0XX	E-2964-0XX
35° CCW	1.5 mm	M-15024-0XX	E-15024-0XX	M-2942-0XX	E-2942-0XX	M-2964-0XX	E-2964-0XX	M-2964-0XX	E-2964-0XX
45° CW	1.5 mm	M-3136-0XX	E-3136-0XX	M-2817-0XX	E-2817-0XX	M-15066-0XX	E-15066-0XX	M-3308-0XX	E-3308-0XX
45° CCW	1.5 mm	M-2510-0XX	E-2510-0XX	M-2698-0XX	E-2698-0XX	M-3308-0XX	E-3308-0XX	M-3308-0XX	E-3308-0XX
55° CW	1.5 mm	M-15400-0XX	—	M-15403-0XX	—	M-15406-0XX	—	M-15406-0XX	—
67½° CW	1.5 mm	M-1182-0XX	—	M-2181-0XX	—	M-1483-0XX	—	M-1483-0XX	—
67½° CCW	1.5 mm	M-2293-0XX	—	M-2671-0XX	—	M-1481-0XX	—	M-1481-0XX	—
95° CW	1.5 mm	M-3230-0XX	—	M-2643-0XX	—	M-1078-0XX	—	M-1078-0XX	—
95° CCW	1.5 mm	M-1351-0XX	—	M-2223-0XX	—	M-15095-0XX	—	M-15095-0XX	—
110° CW	1.7 mm	M-15401-0XX	—	M-15404-0XX	—	M-15407-0XX	—	M-15407-0XX	—
110° CCW	1.7 mm	M-15402-0XX	—	M-15405-0XX	—	M-15408-0XX	—	M-15408-0XX	—

\* Direction of rotation (cw – clockwise or ccw – counterclockwise) is viewed from the armature end of the solenoid opposite the mounting studs.

Note: The XX in the part number suffix must be filled in with the awg of your choice.

# Ledex® Rotary Solenoids Size 6S Precision Standard Coil

## Coil Specifications

Maximum Duty Cycle	100%	50%	25%	10%	5%
Maximum ON Time (sec) when pulsed continuously <sup>1</sup>	∞	87	36	13	4.6
Maximum ON Time (sec) for single pulse <sup>2</sup>	∞	140	44	16	5.7
Watts (@ 20°C)	32	64	128	320	640
Ampere Turns (@ 20°C)	1240	1760	2490	3920	5555

### Coil Data

awg (0XX) <sup>3</sup>	Resistance (@20°C)	# Turns <sup>4</sup>	VDC (Nom)	VDC (Nom)	VDC (Nom)	VDC (Nom)	VDC (Nom)
23	3.59	432	10.3	14.6	21.0	33.0	46.0
24	5.24	500	13.0	18.4	26.0	41.0	58.0
25	9.51	708	16.7	24.0	33.0	53.0	75.0
26	14.44	858	21.0	30.0	42.0	66.0	94.0
27	23.69	1110	27.0	38.0	53.0	84.0	119.0
28	38.27	1411	34.0	48.0	68.0	106.0	151.0
29	54.62	1638	41.0	59.0	83.0	131.0	185.0
30	93.67	2184	53.0	76.0	107.0	168.0	238.0
31	143.00	2645	67.0	95.0	134.0	211.0	299.0
32	223.00	3328	83.0	118.0	167.0	262.0	372.0
33	338.00	4004	105.0	149.0	210.0	331.0	469.0

## General Specifications

Dielectric Strength	23-31 awg, 1200 VRMS; 32-33 awg, 1500 VRMS
Recommended Minimum Heat Sink	Maximum watts dissipated by solenoid are based on an unrestricted flow of air at 20°C, with solenoid mounted on the equivalent of an aluminium plate measuring 314.5 mm square by 3.2 thick.
Coil Resistance	±5% tolerance
Starting Torque	Gross torque values are shown. For net starting torque, subtract return spring torque
Return Spring Torque	56.5 mNm ±20%
Weight	510.3 g
Dimensions	See page D35

- Continuously pulsed at stated watts and duty cycle.
- Single pulse at stated watts (with coil at ambient room temperature 20°C).
- Other coil awg sizes available, consult factory.
- Reference number of turns.

ROTARY Solenoids

All specifications subject to change without notice.

- No shafts
- 3 tapped holes
- Return spring

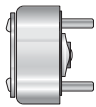

- Armature end shaft
- 3 tapped holes
- Return spring

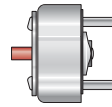

- Base end shaft
- 3 tapped holes
- Return spring

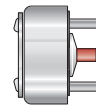

- Double shaft
- 3 tapped holes
- Return spring

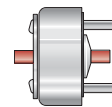

Standard	Long Life	Standard	Long Life	Standard	Long Life	Standard	Long Life
M-2481-0XX	E-2481-0XX	M-3055-0XX	E-3055-0XX	M-2184-0XX	E-2184-0XX	M-15067-0XX	E-15067-0XX
M-1002-0XX	E-1002-0XX	M-1291-0XX	E-1291-0XX	M-1306-0XX	E-1306-0XX	M-15123-0XX	E-15123-0XX
M-2861-0XX	E-2861-0XX	M-1230-0XX	E-1230-0XX	M-15417-0XX	E-15417-0XX	M-2057-0XX	E-2057-0XX
M-2269-0XX	E-2269-0XX	M-15412-0XX	E-15412-0XX	M-15418-0XX	E-15418-0XX	M-15136-0XX	E-15136-0XX
M-1112-0XX	E-1112-0XX	M-15013-0XX	E-15013-0XX	M-1311-0XX	E-1311-0XX	M-15064-0XX	E-15064-0XX
M-2328-0XX	E-2328-0XX	M-3208-0XX	E-3208-0XX	M-1286-0XX	E-1286-0XX	M-15424-0XX	E-15424-0XX
M-15409-0XX	—	M-15413-0XX	—	M-15419-0XX	—	M-15425-0XX	—
M-2404-0XX	—	M-3264-0XX	—	M-15420-0XX	—	M-15426-0XX	—
M-2661-0XX	—	M-15414-0XX	—	M-15421-0XX	—	M-15427-0XX	—
M-2072-0XX	—	M-2826-0XX	—	M-1313-0XX	—	M-2001-0XX	—
M-2071-0XX	—	M-3002-0XX	—	M-2936-0XX	—	M-15030-0XX	—
M-15410-0XX	—	M-15415-0XX	—	M-15422-0XX	—	M-15428-0XX	—
M-15411-0XX	—	M-15416-0XX	—	M-15423-0XX	—	M-15429-0XX	—

# Ledex® Rotary Solenoids Size 7S Precision Standard Coil

## Performance Specifications

Stroke	Holding Torque <sup>2</sup> (mNm)	Starting Torque (mNm) <sup>1</sup> @ 20°C Maximum Duty Cycle				
		100%	50%	25%	10%	5%
25°	2260.0	1243.0	2689.4	3751.6	4791.2	5265.8
35°	*	678.0	1356.0	2486.0	4294.0	4746.0
45°	1469.0	565.0	994.4	1853.2	3367.4	3706.4
55°	*	*	*	*	*	*
67½°	*	282.5	576.3	1107.4	1977.5	2180.9
95°	678.0	169.5	395.5	723.2	1186.5	1310.8

All data is at 20°C coil temperature. Force (torque) outputs degrade with elevated temperatures.

<sup>1</sup> Gross starting torques are shown. For net available starting torque, subtract return spring torque of 84.8 mNm. ±20%.

<sup>2</sup> Holding torque is shown at the stabilised temperature of 105°C and continuous duty.

\* Consult factory.

## How to Order

- Using the Performance Chart to the left, select one of the five columns which provides the appropriate duty cycle for your application. Reading down this column locate the torque for the stroke you need. For net available starting torque, subtract return spring torque of 84.8 mNm ±20% (if torque is insufficient go to next larger solenoid size).
- Use the chart below to select the model number corresponding to your desired design, stroke and direction of rotation (as viewed from armature end, opposite mounting studs).
- Using the Specification Chart to the right, select the same duty cycle column. Follow down the column into the VDC ratings. Select the voltage which most closely matches your supply voltage. Read across to the left to select the coil awg suffix.
- Replace the last two digits of the model number (XX) with the coil awg number to complete the part number.

Please see [www.ledex.com](http://www.ledex.com) (click on Stock Products tab) for our list of stock products available through our distributors.

All catalogue products manufactured after April 1, 2006 are RoHS Compliant

- Armature cover
- Armature end shaft
- Return spring

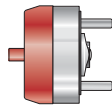

- Armature cover
- Base end shaft
- Return spring

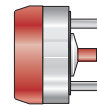

- Armature cover
- Double shaft
- Return spring

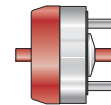

Stroke/ Direction*	Nom. Axial Stroke	Standard		Long Life		Standard		Long Life	
		Standard	Long Life	Standard	Long Life	Standard	Long Life		
25° CW	1.9 mm	M-3057-0XX	E-3057-0XX	M-2477-0XX	E-2477-0XX	M-2309-0XX	E-2309-0XX	M-15009-0XX	E-15009-0XX
25° CCW	1.9 mm	M-1354-0XX	E-1354-0XX	M-2592-0XX	E-2592-0XX	M-15009-0XX	E-15009-0XX	M-15009-0XX	E-15009-0XX
35° CW	2.0 mm	M-15076-0XX	E-15076-0XX	M-2355-0XX	E-2355-0XX	M-3406-0XX	E-3406-0XX	M-15103-0XX	E-15103-0XX
35° CCW	2.0 mm	M-15485-0XX	E-15485-0XX	M-2323-0XX	E-2323-0XX	M-15103-0XX	E-15103-0XX	M-15103-0XX	E-15103-0XX
45° CW	2.0 mm	M-1355-0XX	E-1355-0XX	M-3070-0XX	E-3070-0XX	M-1428-0XX	E-1428-0XX	M-15054-0XX	E-15054-0XX
45° CCW	2.0 mm	M-1356-0XX	E-1356-0XX	M-3148-0XX	E-3148-0XX	M-15054-0XX	E-15054-0XX	M-15054-0XX	E-15054-0XX
55° CW	2.0 mm	M-15486-0XX	—	M-15487-0XX	—	M-15488-0XX	—	M-15488-0XX	—
67½° CW	2.0 mm	M-2809-0XX	—	M-2400-0XX	—	M-1480-0XX	—	M-1480-0XX	—
67½° CCW	2.0 mm	M-15061-0XX	—	M-2303-0XX	—	M-1484-0XX	—	M-1484-0XX	—
95° CW	2.2 mm	M-1178-0XX	—	M-3069-0XX	—	M-1334-0XX	—	M-1334-0XX	—
95° CCW	2.2 mm	M-1357-0XX	—	M-2858-0XX	—	M-15121-0XX	—	M-15121-0XX	—

\* Direction of rotation (cw – clockwise or ccw – counterclockwise) is viewed from the armature end of the solenoid opposite the mounting studs.

Note: The XX in the part number suffix must be filled in with the awg of your choice.

# Ledex® Rotary Solenoids Size 7S Precision Standard Coil

## Coil Specifications

Maximum Duty Cycle	100%	50%	25%	10%	5%
Maximum ON Time (sec) when pulsed continuously <sup>1</sup>	∞	80	38	16	5.7
Maximum ON Time (sec) for single pulse <sup>2</sup>	∞	138	50	18	6.4
Watts (@ 20°C)	35	70	140	350	700
Ampere Turns (@ 20°C)	1570	2230	3150	5000	7034

### Coil Data

awg (0XX) <sup>3</sup>	Resistance (@20°C)	# Turns <sup>4</sup>	VDC (Nom)	VDC (Nom)	VDC (Nom)	VDC (Nom)	VDC (Nom)
23	8.09	780	16.3	23.0	33.0	52.0	73.0
24	12.34	949	21.0	29.0	41.0	65.0	92.0
25	18.62	1148	26.0	37.0	52.0	83.0	116.0
26	30.84	1472	33.0	47.0	66.0	105.0	147.0
27	48.77	1854	41.0	59.0	83.0	132.0	185.0
28	81.14	2436	52.0	74.0	105.0	167.0	234.0
29	121.0	2944	65.0	92.0	130.0	206.0	290.0
30	190.0	3650	82.0	116.0	164.0	261.0	367.0
31	275.0	4175	103.0	147.0	208.0	329.0	463.0
32	440.0	5292	130.0	169.0	239.0	380.0	—
33	715.0	6650	158.0	223.0	316.0	—	—

## General Specifications

Dielectric Strength	23-29 awg, 1200 VRMS; 30-33 awg, 1500 VRMS
Recommended Minimum Heat Sink	Maximum watts dissipated by solenoid are based on an unrestricted flow of air at 20°C, with solenoid mounted on the equivalent of an aluminium plate measuring 384.5 mm square by 3.2 mm thick.
Coil Resistance	23-30 awg, ±5% tolerance; 31-33 awg, ±10% tolerance
Starting Torque	Gross torque values are shown. For net starting torque, subtract return spring torque
Return Spring Torque	84.8 mNm ±20%
Weight	1.020 kgs
Dimensions	See page D36

- Continuously pulsed at stated watts and duty cycle.
- Single pulse at stated watts (with coil at ambient room temperature 20°C).
- Other coil awg sizes available, consult factory.
- Reference number of turns.

All specifications subject to change without notice.

- No shafts
- 3 tapped holes
- Return spring

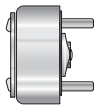

- Armature end shaft
- 3 tapped holes
- Return spring

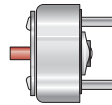

- Base end shaft
- 3 tapped holes
- Return spring

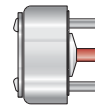

- Double shaft
- 3 tapped holes
- Return spring

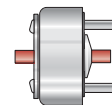

ROTARY Solenoids

Standard	Long Life	Standard	Long Life	Standard	Long Life	Standard	Long Life
M-1352-0XX	E-1352-0XX	M-15491-0XX	E-15491-0XX	M-2490-0XX	E-2490-0XX	M-2415-0XX	E-2415-0XX
M-2590-0XX	E-2590-0XX	M-1197-0XX	E-1197-0XX	M-3362-0XX	E-3362-0XX	M-15116-0XX	E-15116-0XX
M-2388-0XX	E-2388-0XX	M-15492-0XX	E-15492-0XX	M-15498-0XX	E-15498-0XX	M-15134-0XX	E-15134-0XX
M-15616-0XX	E-15616-0XX	M-15493-0XX	E-15493-0XX	M-1467-0XX	E-1467-0XX	M-15137-0XX	E-15137-0XX
M-2950-0XX	E-2950-0XX	M-3007-0XX	E-3007-0XX	M-1312-0XX	E-1312-0XX	M-15502-0XX	E-15502-0XX
M-3096-0XX	E-3096-0XX	M-15014-0XX	E-15014-0XX	M-1317-0XX	E-1317-0XX	M-15503-0XX	E-15503-0XX
M-15490-0XX	—	M-15494-0XX	—	M-15499-0XX	—	M-15614-0XX	—
M-3350-0XX	—	M-15495-0XX	—	M-15500-0XX	—	M-15504-0XX	—
M-15158-0XX	—	M-15496-0XX	—	M-15501-0XX	—	M-15505-0XX	—
M-1353-0XX	—	M-15104-0XX	—	M-2869-0XX	—	M-3037-0XX	—
M-3289-0XX	—	M-15497-0XX	—	M-1316-0XX	—	M-15506-0XX	—

# Ledex<sup>®</sup> Rotary Solenoids 1E Dimensions

mm

## Armature Cover Configuration — Armature End Shaft

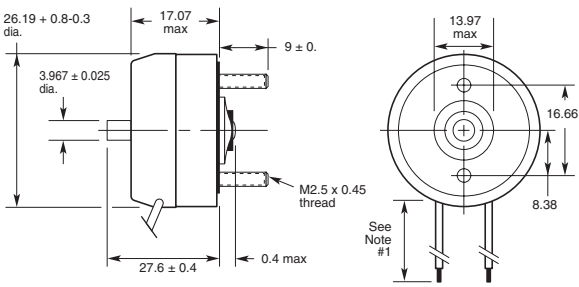

## Armature Cover Configuration — Base End Shaft

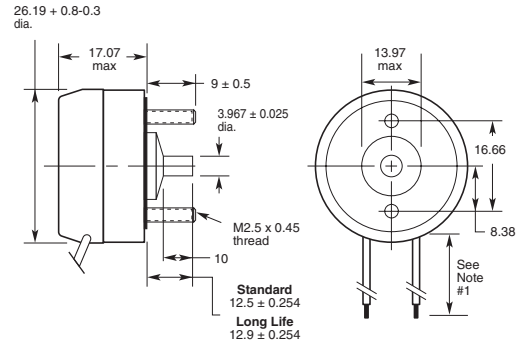

## Armature Cover Configuration — Double Shaft

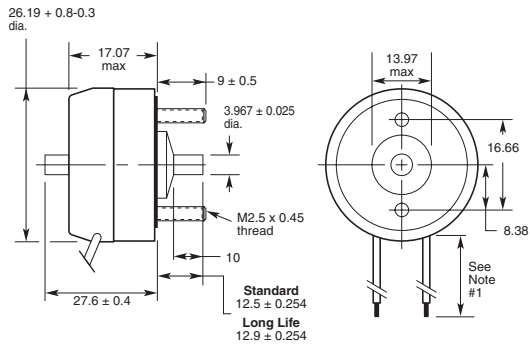

### Notes:

- 1) All configurations have 250 mm minimum leads, 24 awg, PVC insulation.
- 2) For electrical specs and performance charts, see pages D10-D11.

All specifications subject to change without notice.

ROTARY Solenoids

## No Shaft

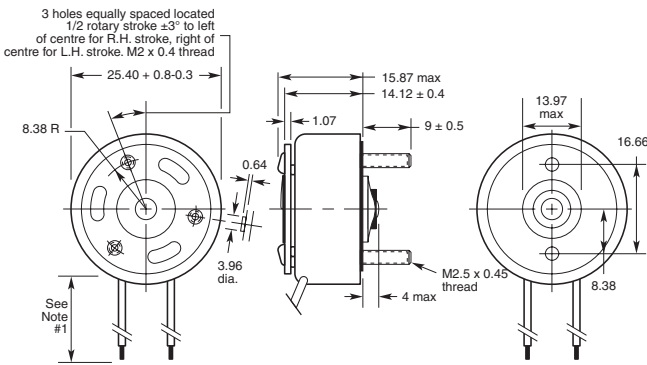

## Base End Shaft

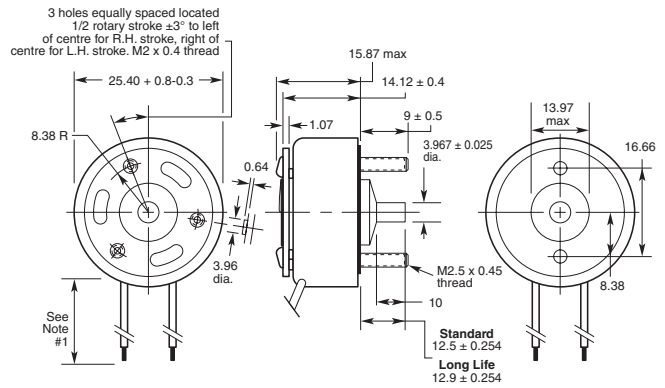

## Armature End Shaft

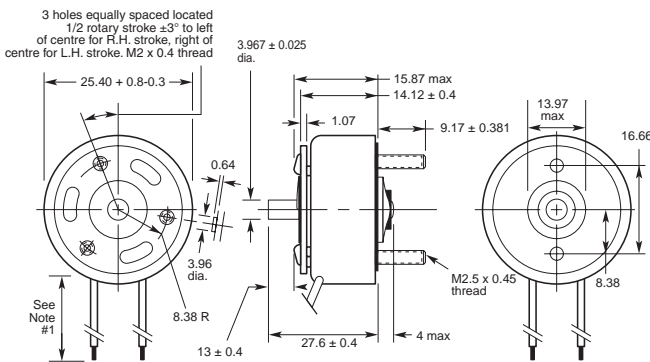

## Double Shaft

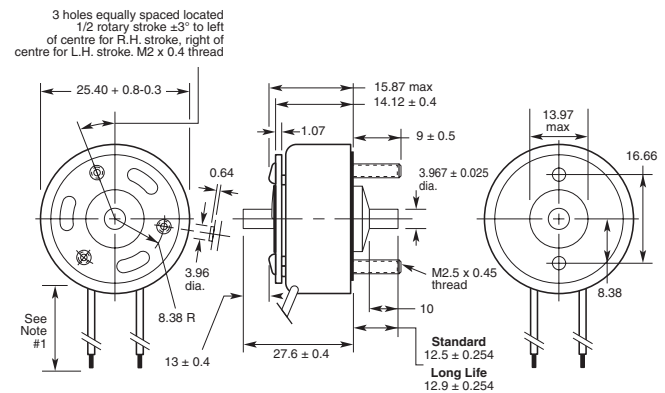

# Ledex<sup>®</sup> Rotary Solenoids 2E Dimensions

mm

## Armature Cover Configuration — Armature End Shaft

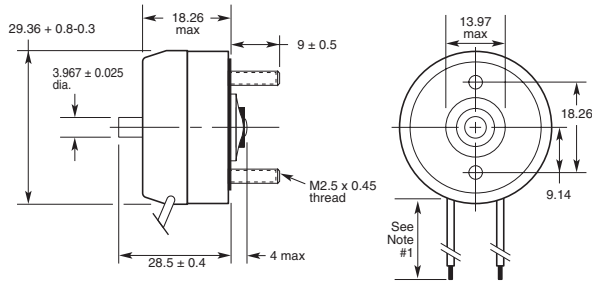

## Armature Cover Configuration — Base End Shaft

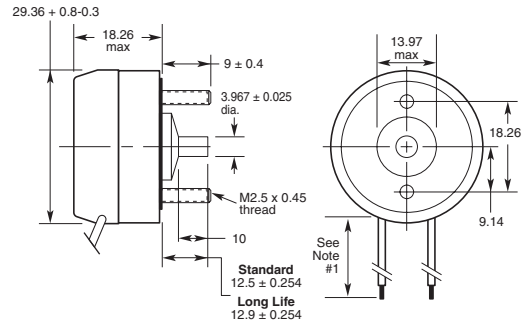

## Armature Cover Configuration — Double Shaft

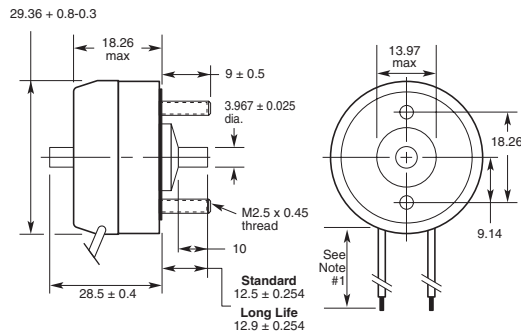

### Notes:

- 1) All configurations have 250 mm minimum leads, 24 awg. PVC insulation.
- 2) For electrical specs and performance charts, see pages D12-D13.

All specifications subject to change without notice.

## No Shaft

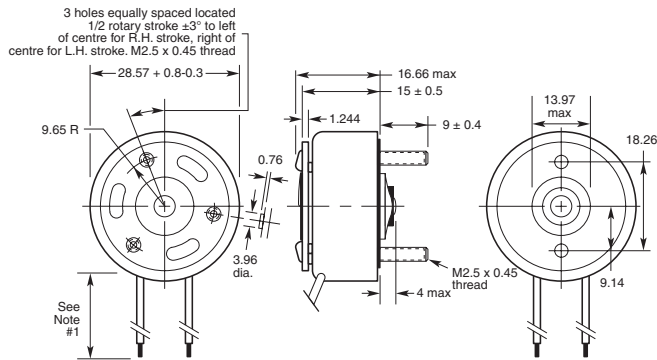

## Base End Shaft

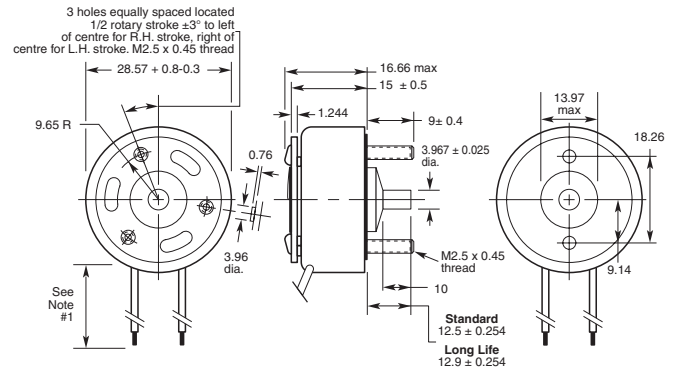

## Armature End Shaft

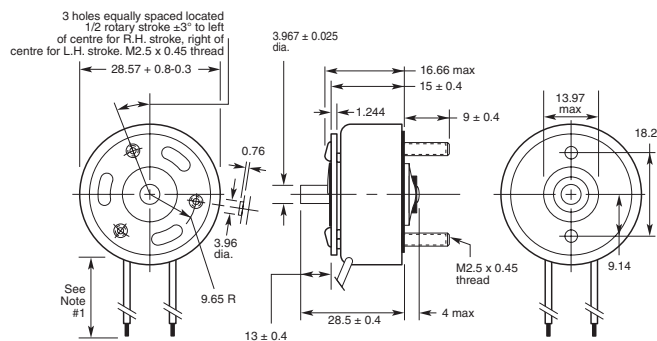

## Double Shaft

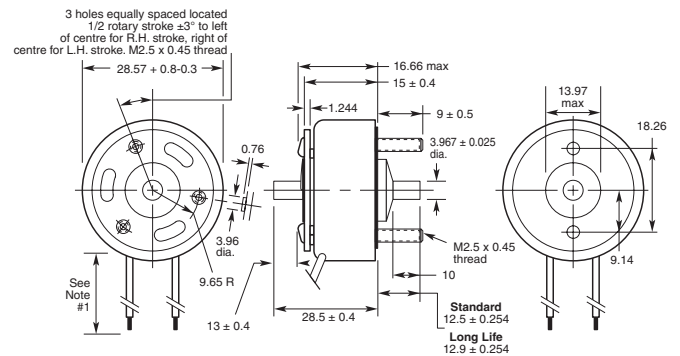

# Ledex<sup>®</sup> Rotary Solenoids 3B Dimensions

mm

## Armature Cover Configuration — Base End Shaft

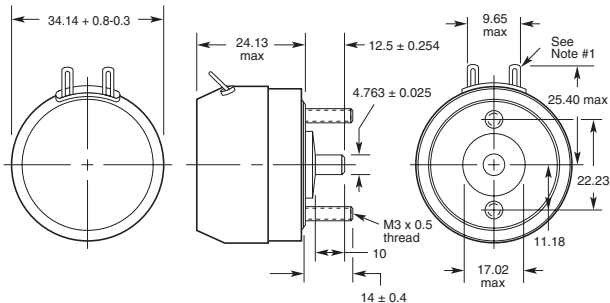

### Notes:

- 1) All configurations have solder lug terminals, 2.36 mm wide x 0.457 mm thick.
- 2) For electrical specs and performance charts, see pages D14-D15.

All specifications subject to change without notice.

ROTARY Solenoids

## No Shaft

3 holes equally spaced located 1/2 rotary stroke  $\pm 3^\circ$  to left of centre for R.H. stroke, right of centre for L.H. stroke. M2.5 x 0.45 thread

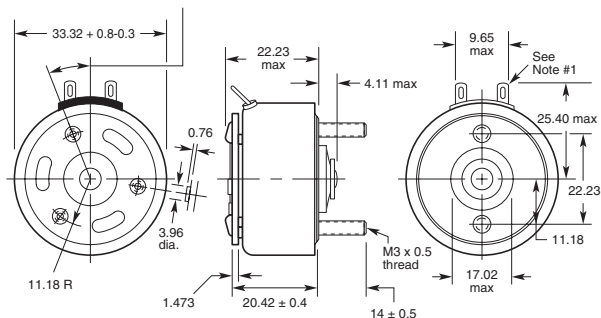

## Base End Shaft

3 holes equally spaced located 1/2 rotary stroke  $\pm 3^\circ$  to left of centre for R.H. stroke, right of centre for L.H. stroke. M2.5 x 0.45 thread

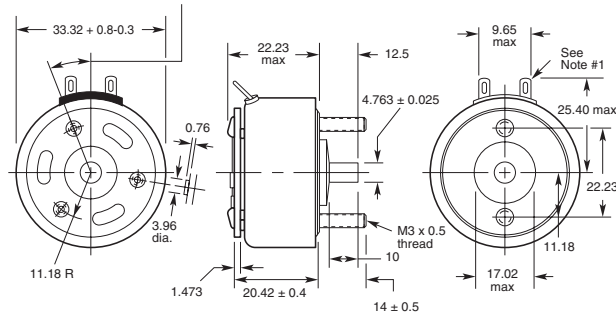

## Armature End Shaft

3 holes equally spaced located 1/2 rotary stroke  $\pm 3^\circ$  to left of centre for R.H. stroke, right of centre for L.H. stroke. M2.5 x 0.45 thread

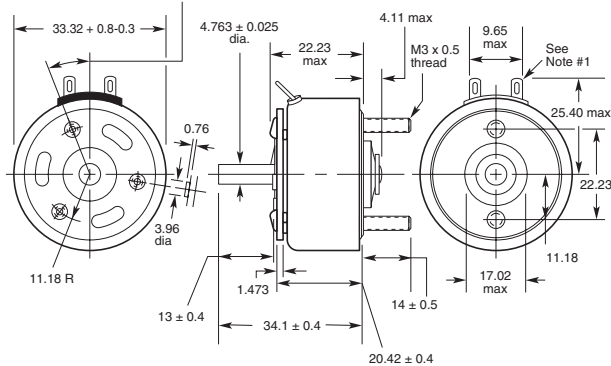

## Double Shaft

3 holes equally spaced located 1/2 rotary stroke  $\pm 3^\circ$  to left of centre for R.H. stroke, right of centre for L.H. stroke. M2.5 x 0.45 thread

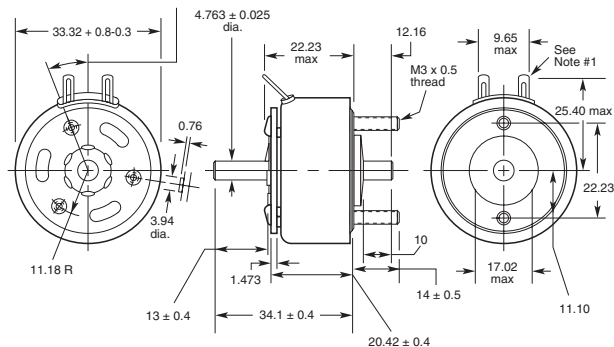

# Ledex® Rotary Solenoids 3E Dimensions

mm

## Armature Cover Configuration — Armature End Shaft

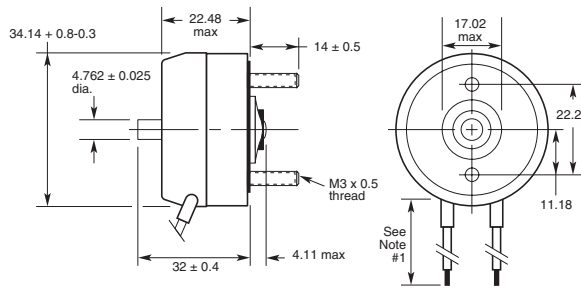

## Armature Cover Configuration — Base End Shaft

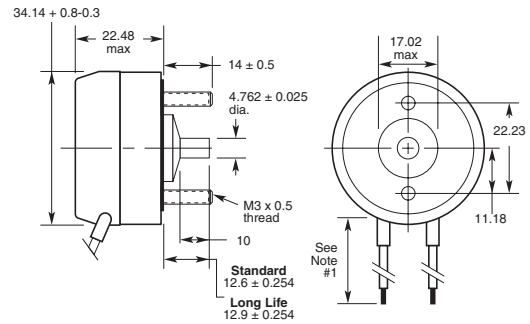

## Armature Cover Configuration — Double Shaft

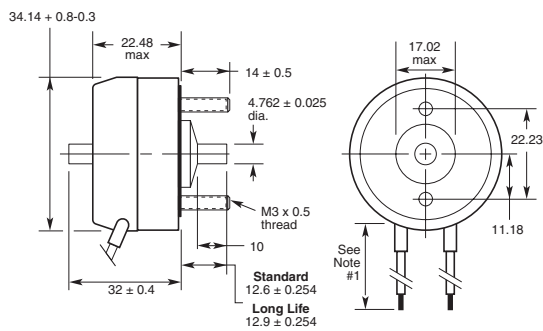

### Notes:

- 1) All configurations have 250 mm minimum leads, 24 awg. PVC insulation.
- 2) For electrical specs and performance charts, see pages D16-D17.

All specifications subject to change without notice.

## No Shaft

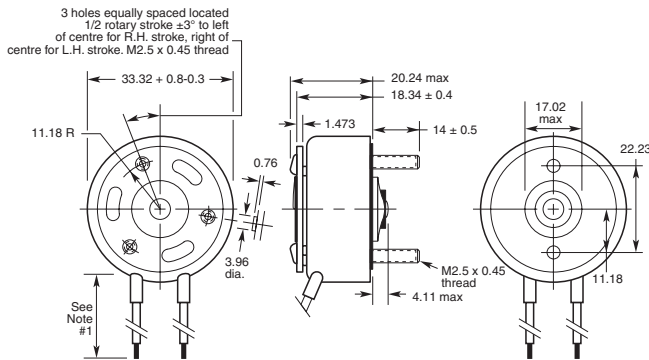

## Base End Shaft

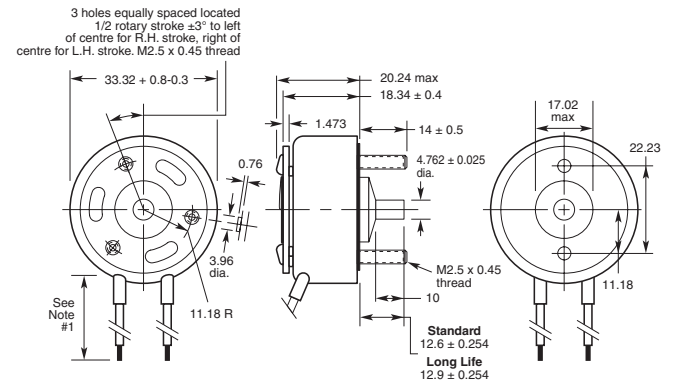

## Armature End Shaft

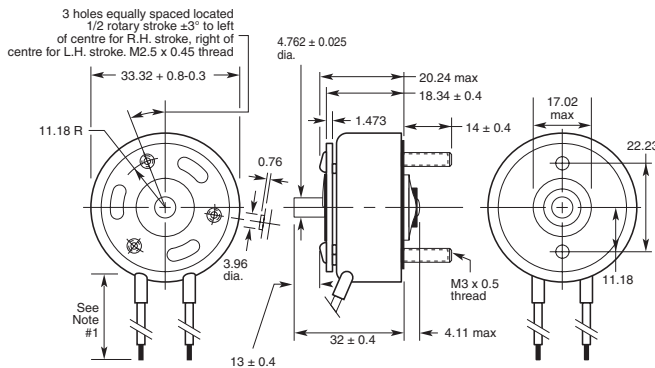

## Double Shaft

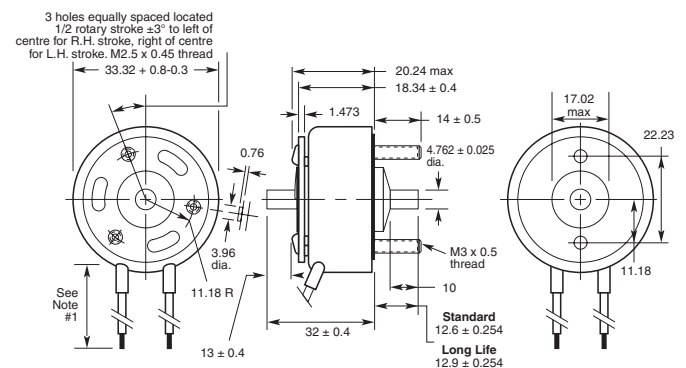

# Ledex<sup>®</sup> Rotary Solenoids 4E Dimensions

mm

## Armature Cover Configuration — Armature End Shaft

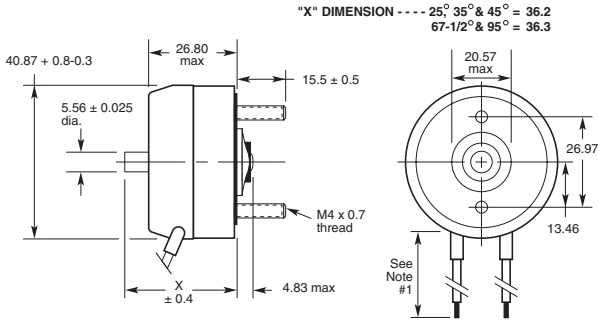

## Armature Cover Configuration — Base End Shaft

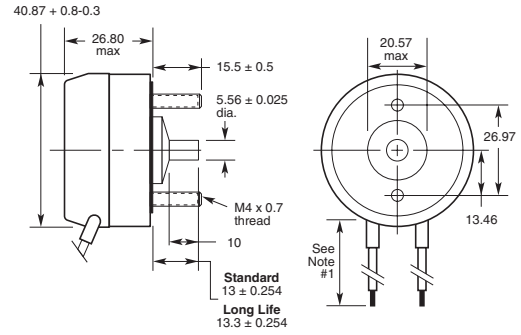

## Armature Cover Configuration — Double Shaft

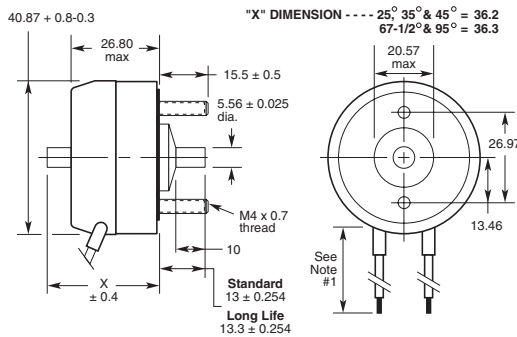

### Notes:

- 1) All configurations have 250 mm minimum leads, 24 awg, PVC insulation.
- 2) For electrical specs and performance charts, see pages D18-D19.

All specifications subject to change without notice.

## No Shaft

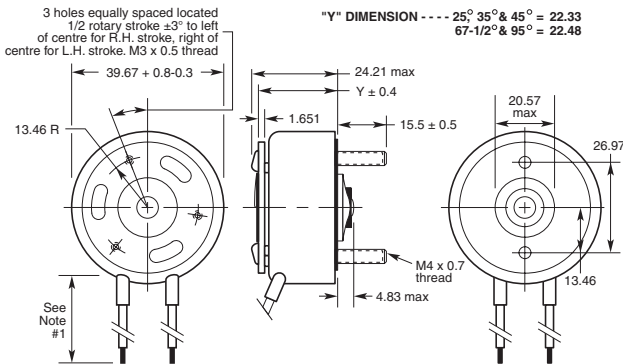

## Base End Shaft

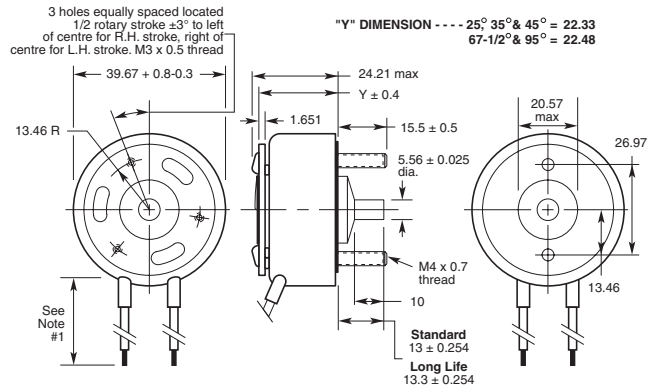

## Armature End Shaft

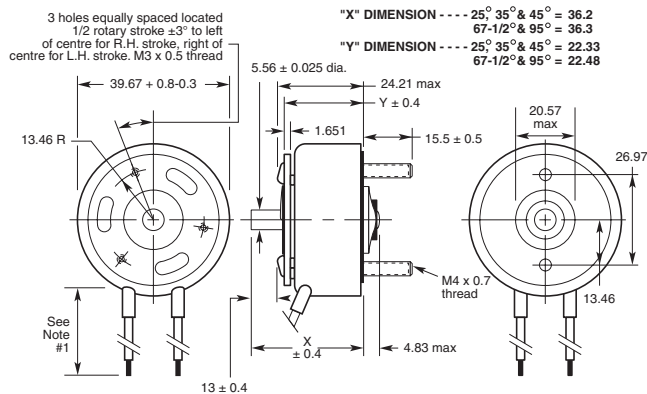

## Double Shaft

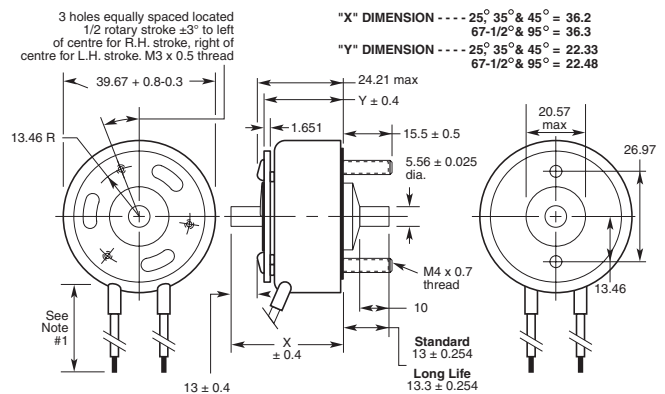

# Ledex<sup>®</sup> Rotary Solenoids 5B Dimensions

mm

## Armature Cover Configuration — Base End Shaft

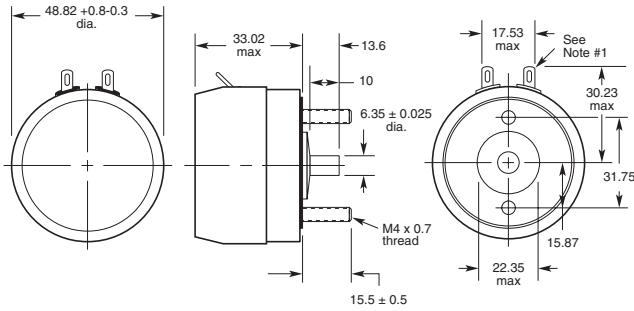

### Notes:

- 1) All configurations have solder lug terminals, 4.32 mm wide x 0.457 mm thick.
- 2) For electrical specs and performance charts, see pages D20-D21.

All specifications subject to change without notice.

ROTARY Solenoids

## No Shaft

3 holes equally spaced located 1/2 rotary stroke  $\pm 3^\circ$  to left of centre for R.H. stroke, right of centre for L.H. stroke. M3 x 0.5 thread

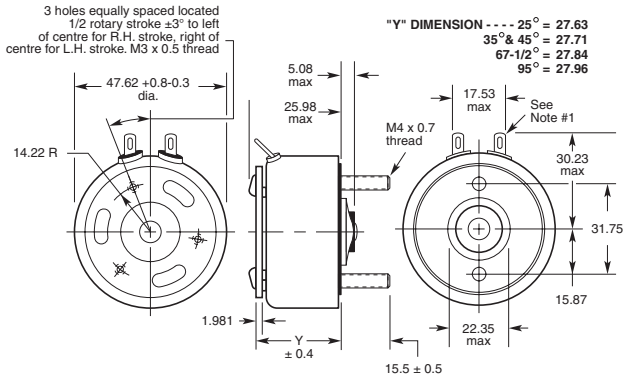

"Y" DIMENSION ---  $25^\circ = 27.63$   
 $35^\circ \& 45^\circ = 27.71$   
 $67-1/2^\circ = 27.84$   
 $95^\circ = 27.96$

## Base End Shaft

3 holes equally spaced located 1/2 rotary stroke  $\pm 3^\circ$  to left of centre for R.H. stroke, right of centre for L.H. stroke. M3 x 0.5 thread

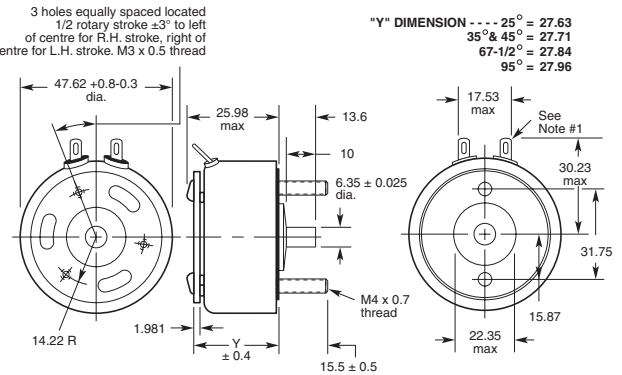

"Y" DIMENSION ---  $25^\circ = 27.63$   
 $35^\circ \& 45^\circ = 27.71$   
 $67-1/2^\circ = 27.84$   
 $95^\circ = 27.96$

## Armature End Shaft

3 holes equally spaced located 1/2 rotary stroke  $\pm 3^\circ$  to left of centre for R.H. stroke, right of centre for L.H. stroke. M3 x 0.5 thread

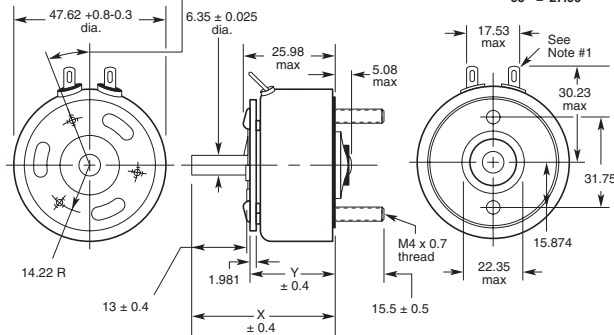

"X" DIMENSION ---  $25^\circ = 41.5$   
 $35^\circ \& 45^\circ = 41.6$   
 $67-1/2^\circ = 41.7$   
 $95^\circ = 41.8$

"Y" DIMENSION ---  $25^\circ = 27.63$   
 $35^\circ \& 45^\circ = 27.71$   
 $67-1/2^\circ = 27.84$   
 $95^\circ = 27.96$

## Double Shaft

3 holes equally spaced located 1/2 rotary stroke  $\pm 3^\circ$  to left of centre for R.H. stroke, right of centre for L.H. stroke. M3 x 0.5 thread

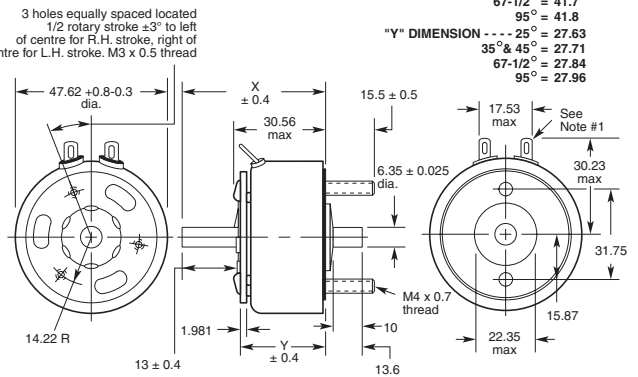

"X" DIMENSION ---  $25^\circ = 41.5$   
 $35^\circ \& 45^\circ = 41.6$   
 $67-1/2^\circ = 41.7$   
 $95^\circ = 41.8$

"Y" DIMENSION ---  $25^\circ = 27.63$   
 $35^\circ \& 45^\circ = 27.71$   
 $67-1/2^\circ = 27.84$   
 $95^\circ = 27.96$

# Ledex<sup>®</sup> Rotary Solenoids 5S Dimensions

mm

## Armature Cover Configuration — Armature End Shaft

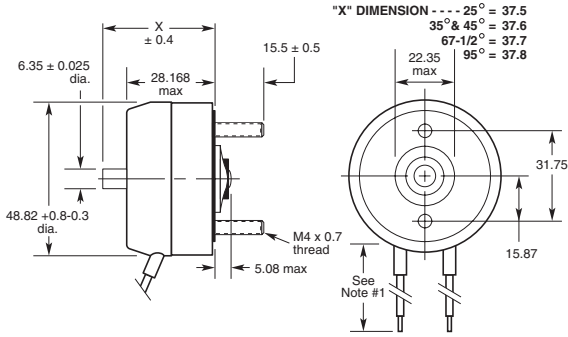

## Armature Cover Configuration — Base End Shaft

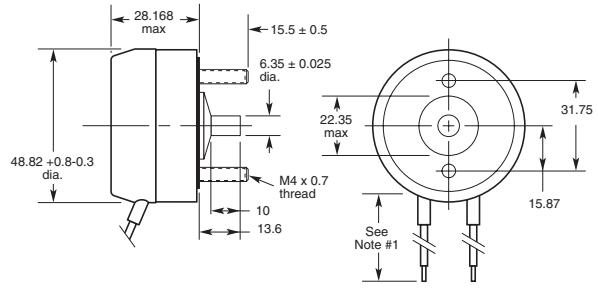

## Armature Cover Configuration — Double Shaft

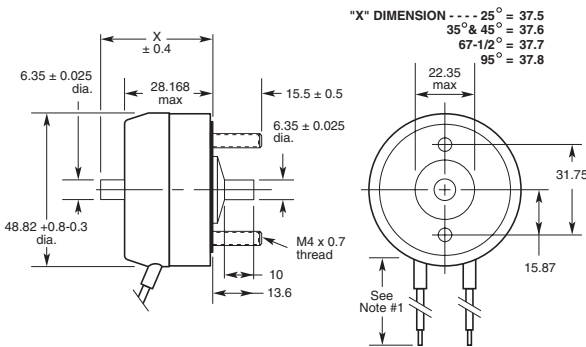

### Notes:

- 1) All configurations have 250 mm minimum leads, 24 awg, PVC insulation.
- 2) For electrical specs and performance charts, see pages D22-D23.

All specifications subject to change without notice.

## No Shaft

3 holes equally spaced located 1/2 rotary stroke ±3° to left of centre for R.H. stroke, right of centre for L.H. stroke. M3 x 0.5 thread

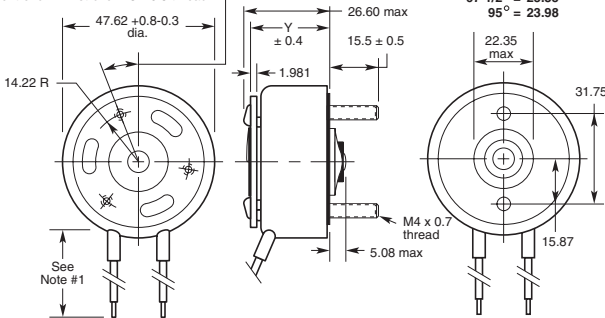

## Base End Shaft

3 holes equally spaced located 1/2 rotary stroke ±3° to left of centre for R.H. stroke, right of centre for L.H. stroke. M3 x 0.5 thread

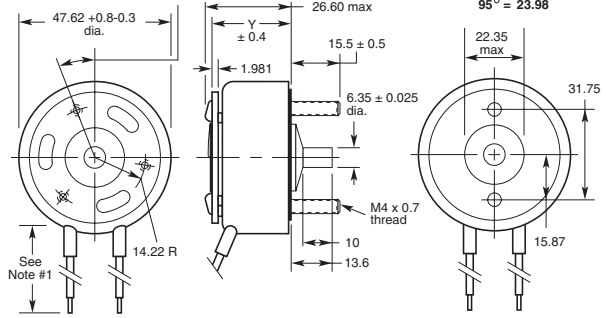

## Armature End Shaft

3 holes equally spaced located 1/2 rotary stroke ±3° to left of centre for R.H. stroke, right of centre for L.H. stroke. M3 x 0.5 thread

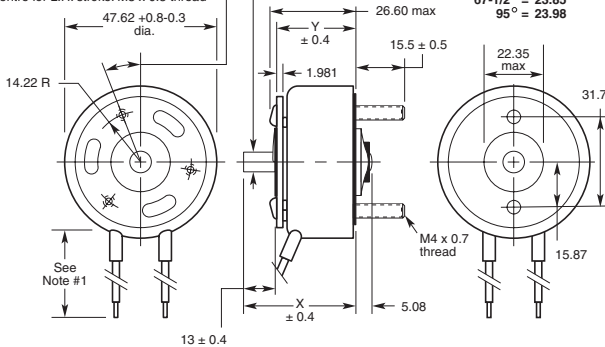

## Double Shaft

3 holes equally spaced located 1/2 rotary stroke ±3° to left of centre for R.H. stroke, right of centre for L.H. stroke. M3 x 0.5 thread

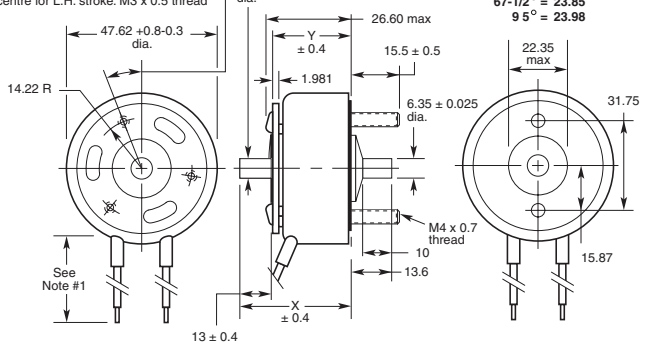

# Ledex<sup>®</sup> Rotary Solenoids 6S Dimensions

mm

## Armature Cover Configuration — Armature End Shaft

## Armature Cover Configuration — Base End Shaft

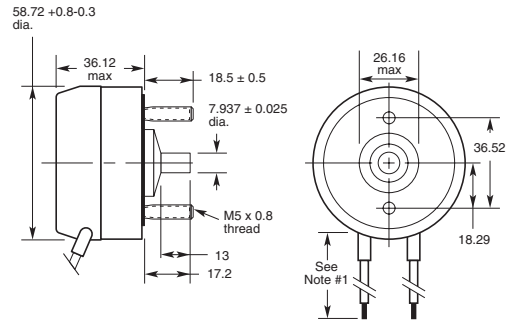
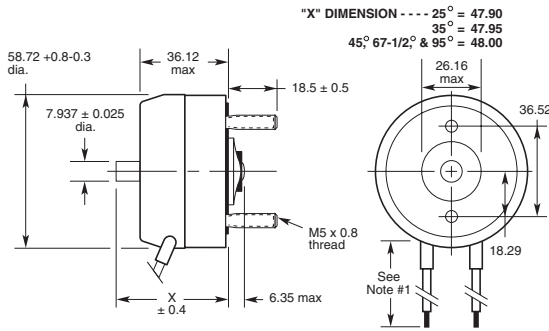

## Armature Cover Configuration — Double Shaft

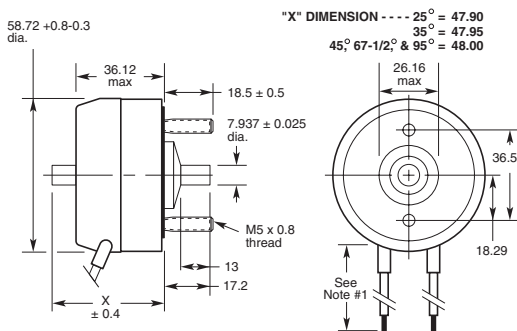

### Notes:

- 1) All configurations have 250 mm minimum leads, 24 awg, PVC insulation.
- 2) For electrical specs and performance charts, see pages D24-D25.

All specifications subject to change without notice.

## No Shaft

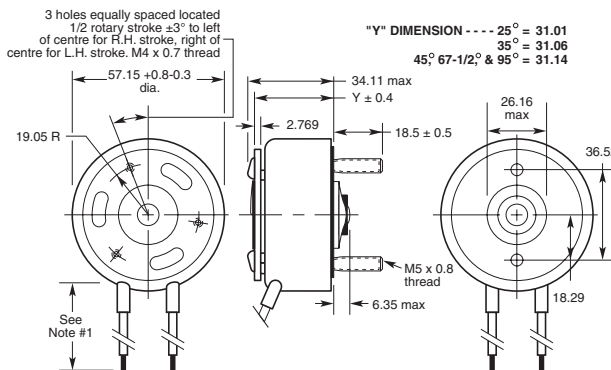

## Base End Shaft

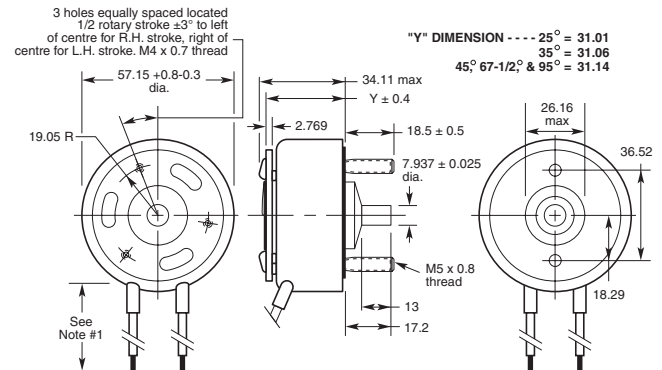

## Armature End Shaft

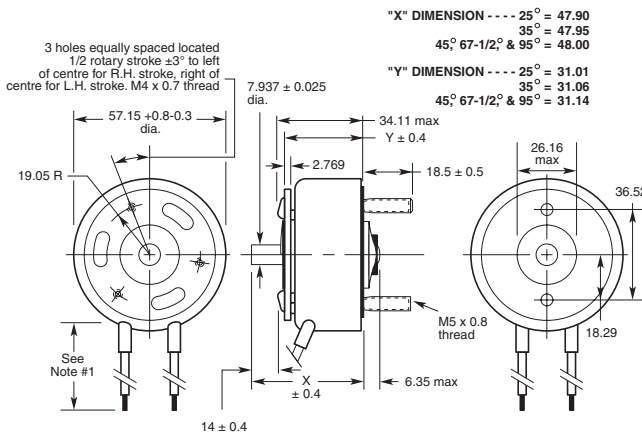

## Double Shaft

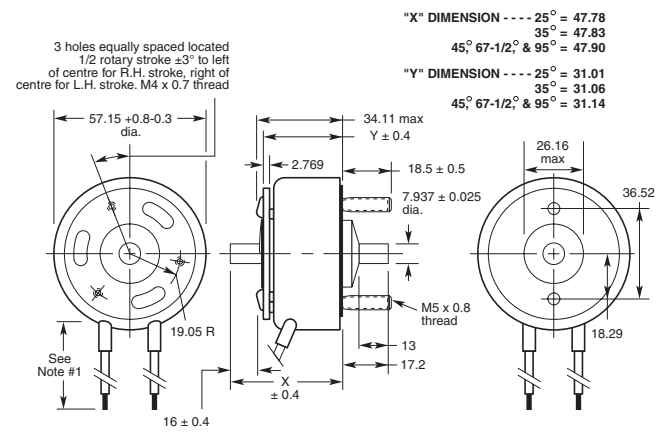

ROTARY Solenoids

# Ledex<sup>®</sup> Rotary Solenoids 7S Dimensions

mm

## Armature Cover Configuration — Armature End Shaft

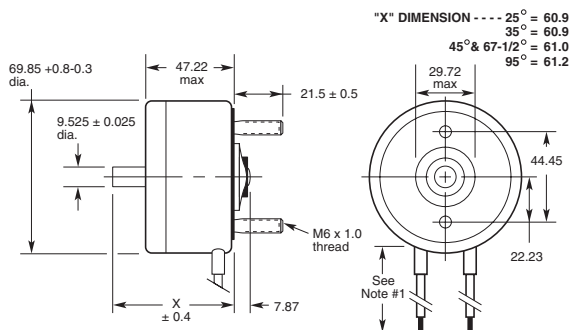

## Armature Cover Configuration — Base End Shaft

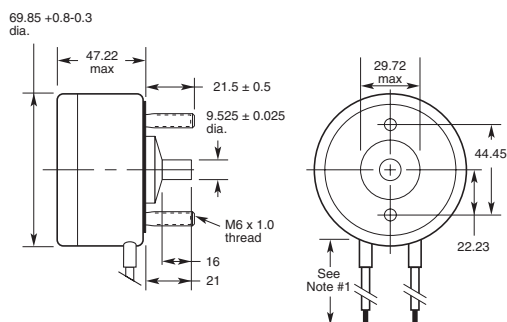

## Armature Cover Configuration — Double Shaft

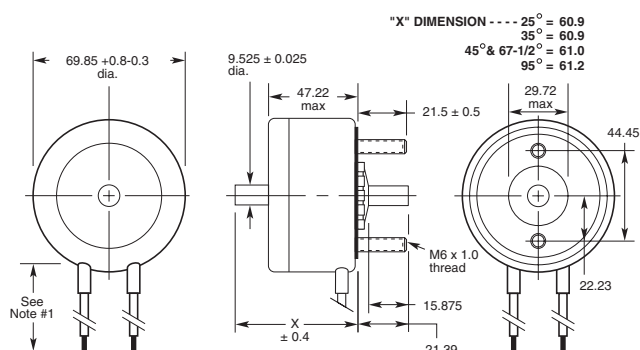

### Notes:

- 1) All configurations have 250 mm minimum leads, 24 awg, PVC insulation.
- 2) For electrical specs and performance charts, see pages D26-D27.

All specifications subject to change without notice.

## No Shaft

3 holes equally spaced located 1/2 rotary stroke ±3° to left of centre for R.H. stroke, right of centre for L.H. stroke. M5 x 0.8 thread

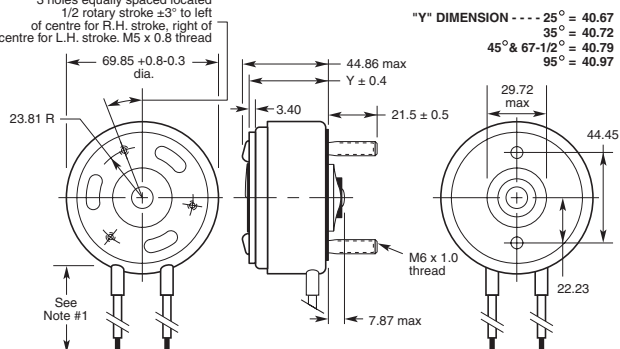

## Base End Shaft

3 holes equally spaced located 1/2 rotary stroke ±3° to left of centre for R.H. stroke, right of centre for L.H. stroke. M5 x 0.8 thread

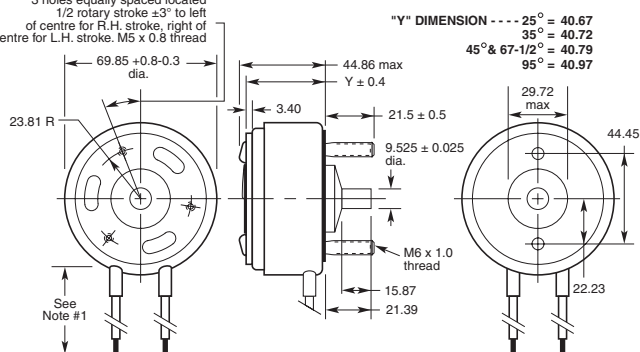

## Armature End Shaft

3 holes equally spaced located 1/2 rotary stroke ±3° to left of centre for R.H. stroke, right of centre for L.H. stroke. M5 x 0.8 thread

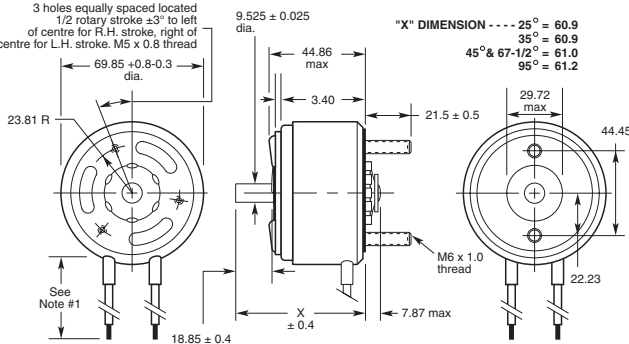

## Double Shaft

3 holes equally spaced located 1/2 rotary stroke ±3° to left of centre for R.H. stroke, right of centre for L.H. stroke. M5 x 0.8 thread

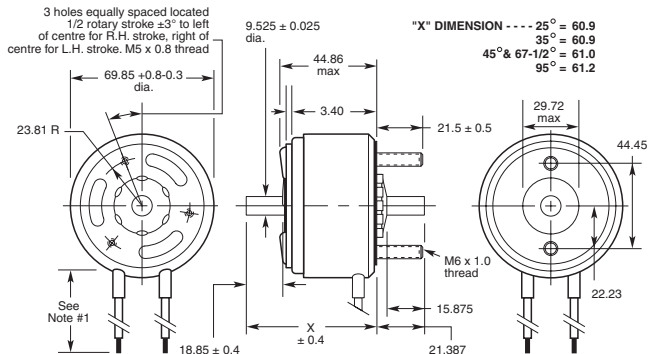

## Soft Shift® Linear Solenoids

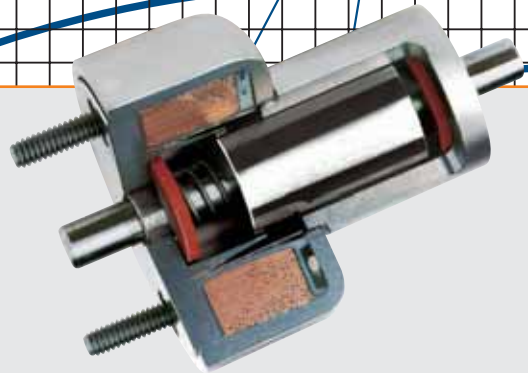
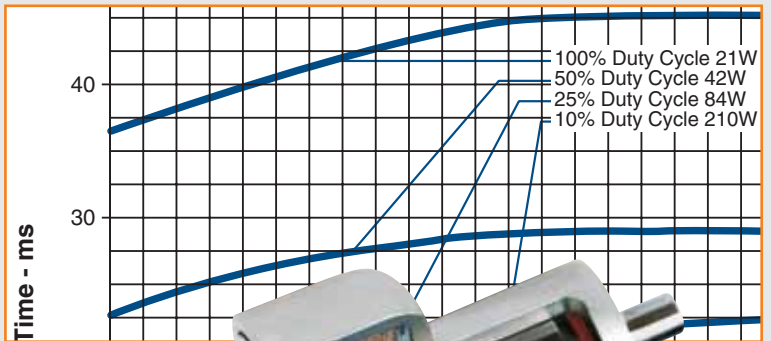

# Soft Shift® Solenoids

LINEAR Soft Shift®



- Variable positioning linear device
- Slow, smooth motion
- High starting force
- Quiet operation
- 10<sup>6</sup> actuation life rating



All catalogue products manufactured after April 1, 2006 are RoHS Compliant

Soft Shift solenoids have a unique construction which allows easy transition from snap action to variable position.

Using the same power, starting force is three to five times higher than standard solenoids at the fully de-energised position. This is advantageous for starting inertial loads or detented mechanisms, and for conserving electrical power.

In snap action applications, typical solenoids move to the end of the stroke within milliseconds, with a characteristic increase in ending force and acceleration. With the Soft Shift solenoid plunger, however, velocity can be controlled by ramping the input current for slow, noiseless operation.

For applications where variable positioning is desired, closed loop control can be accomplished by adding electronic controls. This gives accurate, repeatable action.

The essentially horizontal force curves prevent rapid acceleration at the end of the stroke, avoiding the excessive wear, noise and vibration that characterise standard solenoids. A Soft Shift solenoid can be a low-cost alternative to a linear stepping motor with a lead screw for up to and including a 10.7 mm stroke.

## Performance Curves

The performance curves in this section serve as guides to determine the solenoid size needed to produce a desired force at a given stroke, duty cycle, and power source. All curves were developed under the following standard test conditions: ambient temperature of 20°C, 65% relative humidity.

## Starting Force

When determining an application's force requirement, apply a 1.5 safety factor. For example: a load requiring 1.0 N of force should utilise a solenoid providing 1.0 N x 1.5 or 1.5 N of force.

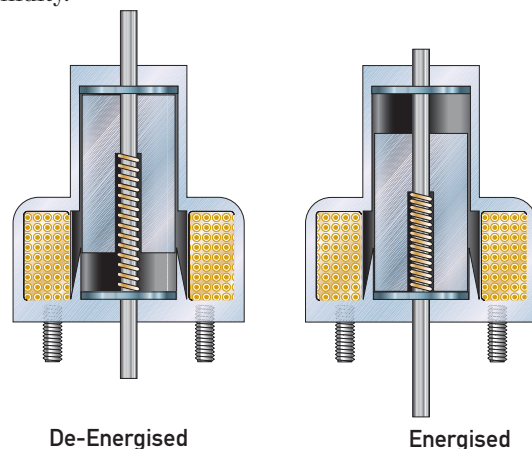

# Soft Shift® Solenoids

## Duty Cycle

Duty cycle is determined by:  $ON\ time / (ON + OFF\ time)$ .

For example: a solenoid is actuated for 30 seconds, then off for 90 seconds.  
 $30\ sec\ ON / (30\ Sec\ ON + 90\ sec\ OFF) = 30/120 = 1/4$  or 25% duty cycle.

Ledex Soft Shift® solenoids are rated for various duty cycles ranging from continuous to 10% duty.

Note that maximum ON time for a particular application can be a factor which overrides the duty cycle rating. For example, at 25% duty cycle, the maximum ON time for a given Soft Shift solenoid is 36 seconds. If, however, the solenoid is operated at a cycle rate which enables the unit to return to ambient temperature between ON cycles, then the maximum ON time is extended somewhat. In the above example, this extended ON time is 44 seconds. Maximum ON time ratings are listed on the individual model specification pages.

## Life

When selecting a Soft Shift solenoid, as with any other solenoid style, it is important to consider the effects of heat on life. When used with a constant voltage supply, an increase in coil temperature reduces the work output and the life of the unit. Standard life is 10,000,000 operations.

## Power Requirements

Voltage applied to the solenoid must be matched to the coil wire size for proper operation. Solenoids are catalogued in coil awgs ranging from #25 up to #35 to accommodate your input power. Refer to the individual model specification pages for coil wire awg recommendations. Many other coil awg sizes are available. Please feel free to contact our application engineering department for availability.

## Applications

Applications for the Soft Shift solenoid include office machinery, medical equipment, keypad testing, locking devices, motion control, hot water solar controllers, robotics, air dampers, optical shutter equipment, and a variety of other industrial applications as well as military uses.

Our catalogue versions are typically designed to utilise the maximum possible stroke capability for each size. Also, the force curves are essentially horizontal. This permits use in applications where quiet operation is a primary concern or where the load to be moved is sensitive to vibration or shock.

A medical fluid analyzer is a good example. The tubes through which fluids are flowing cannot withstand great shock. Excessive shock could cause breakage of the tubes which could then cause a leak of an infectious fluid, for example.

## Typical Examples of Custom Features

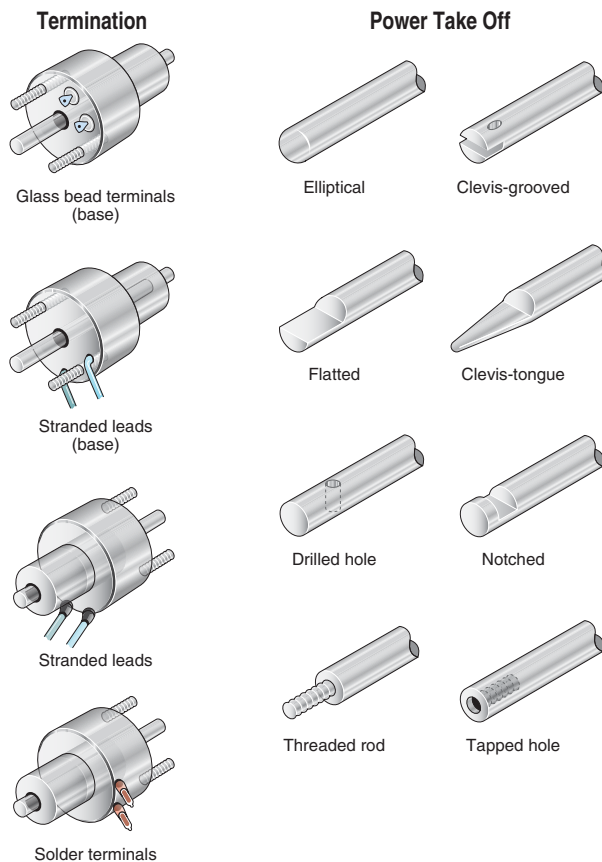

Soft Shift solenoids also contain cushion washers to aid quiet, shock-free operation. In addition, voltage can be applied slowly to take advantage of a slow energizing capability. The de-energizing part of the cycle is also controllable.

A Soft Shift solenoid is also a good choice for long life applications in that its two bearings de-sensitise the unit to side loading. The closed construction also keeps out contaminants, which makes it ideal for rugged applications.

## Options and Modified Designs

Even though many solenoid designs are in stock, our customers often require a product with unique features or performance capabilities. In fact, almost 80% of all solenoids that we make are either modified or custom built to meet our customers' exact application requirements.

So, if you don't find what you're looking for in the catalogue, give us a call to discuss your needs with one of our application engineers.

# Soft Shift® Selection

Soft Shift solenoids are available in five sizes. Use the selection overview chart to determine which size offers the desired performance and mechanical specifications. Refer to the individual size specification pages for complete performance and mechanical data.

All catalogue products manufactured after April 1, 2006 are RoHS Compliant

## Soft Shift Selection Overview

Size	Package Dimensions (mm)		Maximum Stroke mm	Force (N) @ Maximum Stroke and Specified Duty Cycle			
	Dia.	Length		100%	50%	25%	10%
2EPM ●	28.6	25.3	4.1	4.45	6.23	8.9	16.91
3EPM	33.3	31.9	6.4	4.45	8.46	10.24	19.14
4EPM	39.7	37.4	7.6	8.90	13.35	19.14	33.38
5EPM	47.6	49.1	10.2	13.35	20.02	31.15	55.62
6EPM	57.2	56.2	10.7	31.15	42.72	71.20	131.28

All data is at 20°C coil temperature. Force outputs degrade with elevated temperatures.

LINEAR Soft Shift®

● Well-suited for battery operation.



See the "Battery Operated Solenoids" section for complete information.

## How to Use Soft Shift Performance Charts

1. Select one of the four columns which provides the appropriate duty cycle. (For example 50%.)
2. Reading down this column provides a variety of performance and electrical data including maximum on time, watts, and amp turns.
3. Following down the column further into the VDC ratings, select the voltage which most closely matches your supply voltage. (For example, 12.5 for a 12 VDC power supply.)
4. Read across (to the left) to select the avg suffix to complete the part number when ordering. (In this example using our 2EPM chart, 30 avg is required, thus to order, specify: 196655-030.)

## Performance

Maximum Duty Cycle	100%	50%	25%	10%		
Maximum ON Time (sec) when pulsed continuously	∞	100	36	7		
Maximum ON Time (sec) for single pulse	∞	162	44	8		
Watts (@ 20°C)	7	14	28	70		
Ampere Turns (@ 20°C)	425	602	849	1350		
Coil Data						
avg (0XX)	Resistance (@20°C)	# Turns	VDC (Nom)	VDC (Nom)	VDC (Nom)	VDC (Nom)
24	0.68	130	2.2	3.2	4.5	7.1
25	1.16	174	2.8	4.0	5.7	9.0
26	1.96	231	3.6	5.1	7.2	11.5
27	3.16	296	4.5	6.4	9.0	14.4
28	5.10	378	5.7	8.1	11.5	18.2
29	6.94	423	7.0	9.9	13.9	22.0
30	11.03	530	8.8	12.5	17.7	28.0
31	16.85	649	11.0	15.6	22.0	35.0
32	28.15	858	13.9	19.8	28.0	44.0
33	42.75	1036	17.5	25.0	35.0	56.0
34	69.56	1312	23.0	32.0	45.0	72.0
35	112.00	1674	29.0	40.0	57.0	91.0

Force values for reference only.

All specifications subject to change without notice.

# Soft Shift® Size 2EPM

Part Number: 196655-0XX

All catalogue products manufactured after April 1, 2006 are RoHS Compliant

## Performance

Maximum Duty Cycle	100%	50%	25%	10%
Maximum ON Time (sec) when pulsed continuously <sup>1</sup>	∞	100	36	7
Maximum ON Time (sec) for single pulse <sup>2</sup>	∞	162	44	8
Watts (@ 20°C)	7	14	28	70
Ampere Turns (@ 20°C)	425	602	849	1350

### Coil Data

awg (0XX) <sup>3</sup>	Resistance (@20°C)	# Turns <sup>4</sup>	VDC (Nom)	VDC (Nom)	VDC (Nom)	VDC (Nom)
24	0.68	130	2.2	3.2	4.5	7.1
25	1.16	174	2.8	4.0	5.7	9.0
26	1.96	231	3.6	5.1	7.2	11.5
27	3.16	296	4.5	6.4	9.0	14.4
28	5.10	378	5.7	8.1	11.5	18.2
29	6.94	423	7.0	9.9	13.9	22.0
30	11.03	530	8.8	12.5	17.7	28.0
31	16.85	649	11.0	15.6	22.0	35.0
32	28.15	858	13.9	19.8	28.0	44.0
33	42.75	1036	17.5	25.0	35.0	56.0
34	69.56	1312	23.0	32.0	45.0	72.0
35	112.00	1674	29.0	40.0	57.0	91.0

- Continuously pulsed at stated watts and duty cycle
- Single pulse at stated watts (with coil at ambient room temperature 20°C)
- Other coil awg sizes available — please consult factory
- Reference number of turns

## Specifications

Stroke	4.06 ± 0.762 mm
Dielectric Strength	1000 VRMS
Recommended Minimum Heat Sink	Maximum watts dissipated by solenoid are based on an unrestricted flow of air at 20°C, with solenoid mounted on the equivalent of an aluminium plate measuring 85.7 mm square by 3.2 mm thick
Coil Resistance Spring Rate	±5% tolerance on all coil awg 123.2 Nmm:0.6 N ±30% preload reference
Weight	70.9 g
Dimensions	See page E10

## How to Order

Add the coil awg number (0XX) to the part number (for example: to order a 25% duty cycle unit rated at 9 VDC, specify 196655-027).

Please see [www.ledex.com](http://www.ledex.com) (click on Stock Products tab) for our list of stock products available through our distributors.

- Well-suited for battery operation. See the "Battery Operated Solenoids" section for complete information.



## Size 2EPM — Typical Force @ 20°C

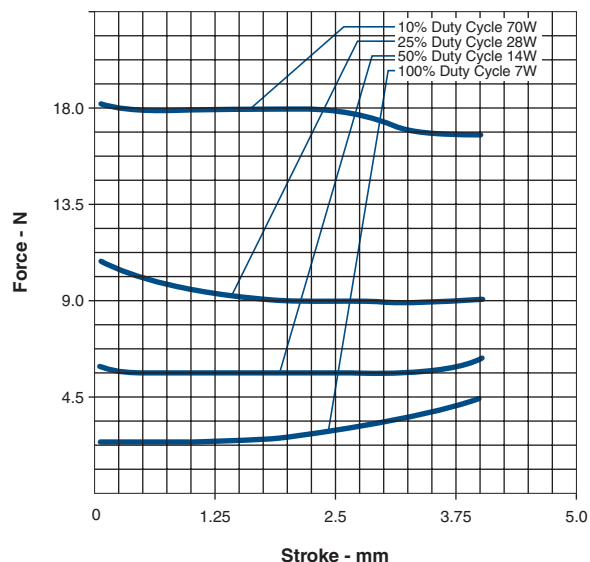

Force values for reference only.

## Size 2EPM — Typical Speed @ No Load, 20°C

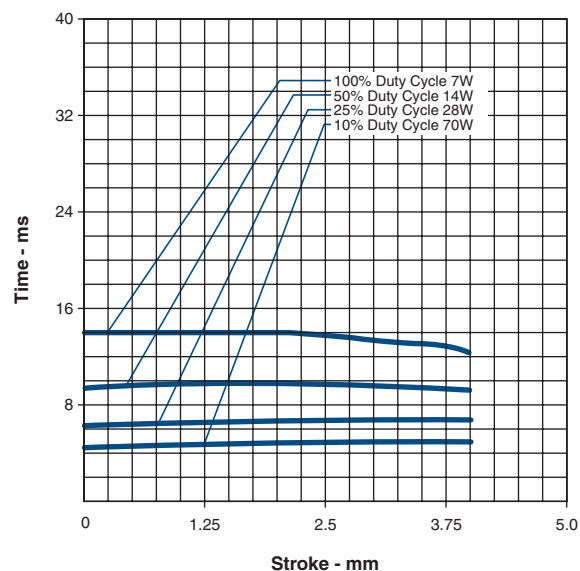

All specifications subject to change without notice.

# Soft Shift® Size 3EPM

Part Number: 196656-0XX

All catalogue products manufactured after April 1, 2006 are RoHS Compliant

## Performance

Maximum Duty Cycle	100%	50%	25%	10%
Maximum ON Time (sec) when pulsed continuously <sup>1</sup>	∞	100	36	8
Maximum ON Time (sec) for single pulse <sup>2</sup>	∞	162	44	9
Watts (@ 20°C)	9	18	36	90
Ampere Turns (@ 20°C)	535	756	1070	1690

### Coil Data

awg (0XX) <sup>3</sup>	Resistance (@20°C)	# Turns <sup>4</sup>	VDC (Nom)	VDC (Nom)	VDC (Nom)	VDC (Nom)
23	0.70	145	2.6	3.7	5.2	8.2
24	1.18	192	3.3	4.6	6.6	10.4
25	1.97	252	4.2	5.9	8.4	13.2
26	3.26	328	5.3	7.5	10.6	16.8
27	5.04	405	6.7	9.4	13.3	21.0
28	8.02	510	8.4	11.9	16.8	27.0
29	12.21	627	10.4	14.7	21.0	33.0
30	19.20	780	13.2	18.6	26.0	42.0
31	31.84	1008	16.9	24.0	34.0	53.0
32	46.97	1215	21.0	29.0	41.0	65.0
33	75.30	1530	26.0	37.0	53.0	83.0

- <sup>1</sup> Continuously pulsed at stated watts and duty cycle
- <sup>2</sup> Single pulse at stated watts (with coil at ambient room temperature 20°C)
- <sup>3</sup> Other coil awg sizes available — please consult factory
- <sup>4</sup> Reference number of turns

## Specifications

Stroke	6.35 ± 0.762 mm
Dielectric Strength	1000 VRMS (23-27 awg); 1200 VRMS (28-33 awg)
Recommended Minimum Heat Sink	Maximum watts dissipated by solenoid are based on an unrestricted flow of air at 20°C, with solenoid mounted on the equivalent of an aluminium plate measuring 117.5 mm square by 3.2 mm thick
Coil Resistance	±5% tolerance on all coil awg
Spring Rate	82.5 Nmm: 1.0 N ±30% preload reference
Weight	113.4 g
Dimensions	See page E10

## How to Order

Add the coil awg number (0XX) to the part number (for example: to order a 25% duty cycle unit rated at 13.3 VDC, specify 196656-027).

Please see [www.ledex.com](http://www.ledex.com) (click on Stock Products tab) for our list of stock products available through our distributors.

LINEAR Soft Shift®

## Size 3EPM — Typical Force @ 20°C

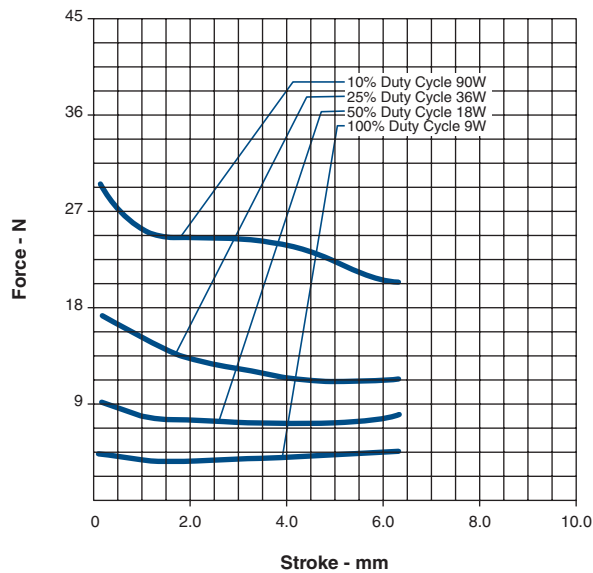

Force values for reference only.

## Size 3EPM — Typical Speed @ No Load, 20°C

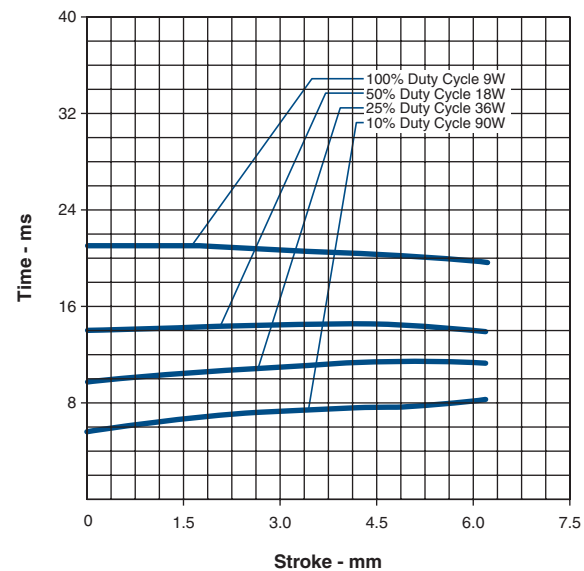

All specifications subject to change without notice.

# Soft Shift® Size 4EPM

Part Number: 196657-0XX

All catalogue products manufactured after April 1, 2006 are RoHS Compliant

## Performance

Maximum Duty Cycle	100%	50%	25%	10%
Maximum ON Time (sec) when pulsed continuously <sup>1</sup>	∞	100	36	9
Maximum ON Time (sec) for single pulse <sup>2</sup>	∞	162	44	10
Watts (@ 20°C)	12.5	25	50	125
Ampere Turns (@ 20°C)	714	1000	1425	2250

Coil Data						
awg (0XX) <sup>3</sup>	Resistance (@20°C)	# Turns <sup>4</sup>	VDC (Nom)	VDC (Nom)	VDC (Nom)	VDC (Nom)
23	1.59	266	4.3	6.0	8.5	13.4
24	2.20	301	5.2	7.3	10.4	16.4
25	3.54	384	6.6	9.2	13.1	21.0
26	5.67	486	8.3	11.7	16.6	26.0
27	8.76	600	10.4	14.6	21.0	33.0
28	13.80	748	13.2	18.5	26.0	42.0
29	22.60	975	16.6	23.0	33.0	52.0
30	34.80	1190	21.0	29.0	42.0	66.0
31	56.70	1520	27.0	37.0	53.0	84.0
32	88.30	1908	33.0	46.0	66.0	104.0
33	138.00	2360	42.0	59.0	83.0	132.0

- <sup>1</sup> Continuously pulsed at stated watts and duty cycle
- <sup>2</sup> Single pulse at stated watts (with coil at ambient room temperature 20°C)
- <sup>3</sup> Other coil awg sizes available — please consult factory
- <sup>4</sup> Reference number of turns

## Specifications

Stroke	7.62 ± 0.762 mm
Dielectric Strength	1000 VRMS (23-24 awg); 1200 VRMS (25-33 awg)
Recommended Minimum Heat Sink	Maximum watts dissipated by solenoid are based on an unrestricted flow of air at 20°C, with solenoid mounted on the equivalent of an aluminium plate measuring 158.8 mm square by 3.2 mm thick
Coil Resistance	±5% tolerance on all coil awg
Spring Rate	159.3 Nmm; 1.6 N ±30% preload reference
Weight	198.4 g
Dimensions	See page E10

## How to Order

Add the coil awg number (0XX) to the part number (for example: to order a 25% duty cycle unit rated at 21 VDC, specify 196657-027).

Please see [www.ledex.com](http://www.ledex.com) (click on Stock Products tab) for our list of stock products available through our distributors.

## Size 4EPM — Typical Force @ 20°C

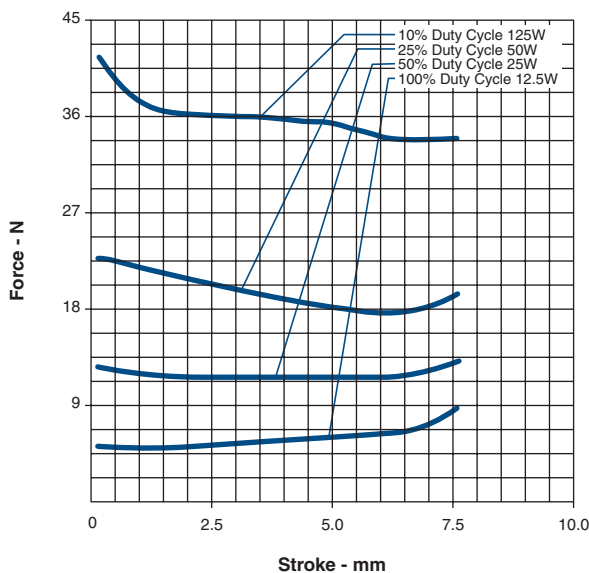

Force values for reference only.

## Size 4EPM — Typical Speed @ No Load, 20°C

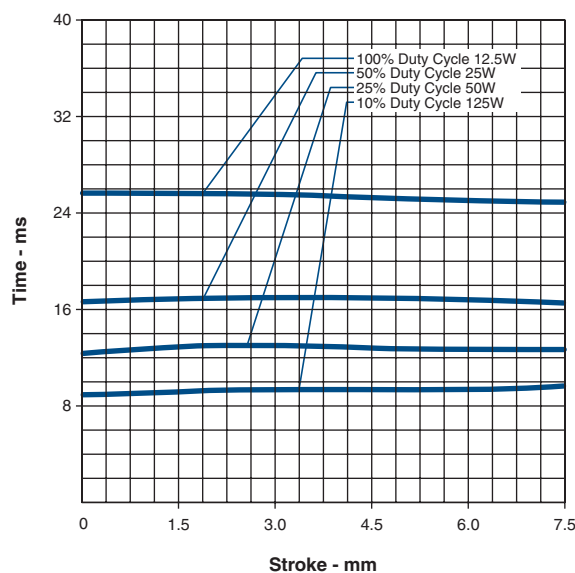

All specifications subject to change without notice.

# Soft Shift® Size 5EPM

Part Number: 196658-0XX

All catalogue products manufactured after April 1, 2006 are RoHS Compliant

## Performance

Maximum Duty Cycle	100%	50%	25%	10%
Maximum ON Time (sec) when pulsed continuously <sup>1</sup>	∞	100	36	10
Maximum ON Time (sec) for single pulse <sup>2</sup>	∞	160	44	13
Watts (@ 20°C)	21	42	84	210
Ampere Turns (@ 20°C)	1015	1440	2030	3210

### Coil Data

avg (0XX) <sup>3</sup>	Resistance (@20°C)	# Turns <sup>4</sup>	VDC (Nom)	VDC (Nom)	VDC (Nom)	VDC (Nom)
23	2.70	384	7.2	10.1	14.3	23.0
24	4.30	486	9.0	12.7	18.0	28.0
25	6.66	590	11.5	16.2	23.0	36.0
26	10.30	737	14.0	20.0	28.0	44.0
27	15.70	900	17.7	25.0	35.0	56.0
28	26.60	1190	23.0	32.0	45.0	72.0
29	38.00	1380	28.0	40.0	56.0	89.0
30	62.10	1768	36.0	51.0	71.0	113.0
31	96.10	2166	45.0	64.0	90.0	143.0
32	157.00	2816	57.0	80.0	113.0	179.0
33	241.00	3432	71.0	101.0	143.0	226.0

- Continuously pulsed at stated watts and duty cycle
- Single pulse at stated watts (with coil at ambient room temperature 20°C)
- Other coil awg sizes available — please consult factory
- Reference number of turns

## Specifications

Stroke	0.400 ± 0.030 inches (10.16 ± 0.762 mm)
Dielectric Strength	1000 VRMS (23 awg); 1200 VRMS (24-33 awg)
Recommended Minimum Heat Sink	Maximum watts dissipated by solenoid are based on an unrestricted flow of air at 20°C, with solenoid mounted on the equivalent of an aluminium plate measuring 190.5 mm square by 3.2 mm thick
Coil Resistance	±5% tolerance on all coil awg
Spring Rate	498.3 Nmm; 2.0 N ±30% preload reference
Weight	340.2 g
Dimensions	See page E10

## How to Order

Add the coil awg number (0XX) to the part number (for example: to order a 25% duty cycle unit rated at 35 VDC, specify 196658-027).

Please see [www.ledex.com](http://www.ledex.com) (click on Stock Products tab) for our list of stock products available through our distributors.

LINEAR Soft Shift®

## Size 5EPM — Typical Force @ 20°C

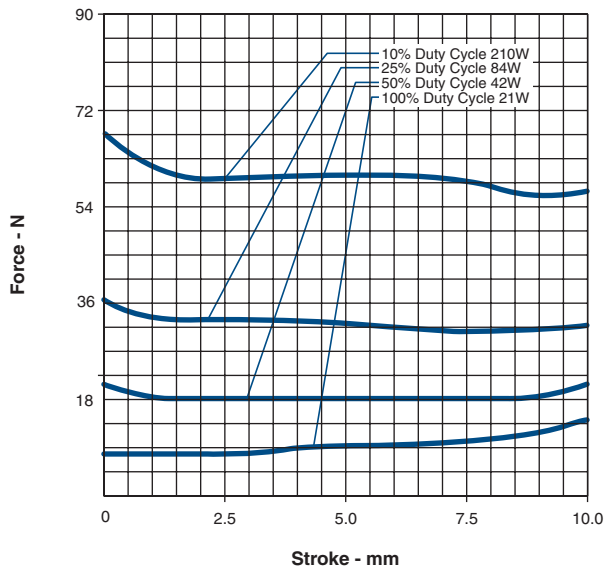

Force values for reference only.

## Size 5EPM — Typical Speed @ No Load, 20°C

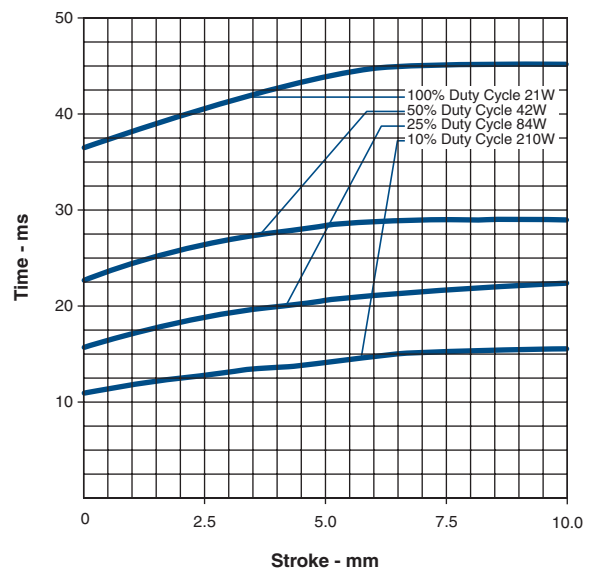

All specifications subject to change without notice.

# Soft Shift® Size 6EPM

Part Number: 196659-0XX

All catalogue products manufactured after April 1, 2006 are RoHS Compliant

## Performance

Maximum Duty Cycle	100%	50%	25%	10%
Maximum ON Time (sec) when pulsed continuously <sup>1</sup>	∞	87	36	13
Maximum ON Time (sec) for single pulse <sup>2</sup>	∞	140	44	16
Watts (@ 20°C)	32	64	128	320
Ampere Turns (@ 20°C)	1480	2080	2940	4620

Coil Data						
awg (0XX) <sup>3</sup>	Resistance (@20°C)	# Turns <sup>4</sup>	VDC (Nom)	VDC (Nom)	VDC (Nom)	VDC (Nom)
23	4.69	567	12.3	17.2	24.0	38.0
24	7.43	710	15.5	22.0	31.0	48.0
25	12.90	960	19.9	28.0	39.0	62.0
26	19.70	1170	25.0	35.0	49.0	78.0
27	32.00	1500	32.0	44.0	63.0	99.0
28	51.60	1904	40.0	56.0	79.0	125.0
29	74.40	2232	49.0	69.0	98.0	154.0
30	126.00	2940	63.0	89.0	126.0	198.0
31	195.00	3611	80.0	112.0	159.0	250.0
32	288.00	4350	98.0	138.0	195.0	306.0
33	427.00	5010	126.0	177.0	251.0	394.0

- <sup>1</sup> Continuously pulsed at stated watts and duty cycle
- <sup>2</sup> Single pulse at stated watts (with coil at ambient room temperature 20°C)
- <sup>3</sup> Other coil awg sizes available — please consult factory
- <sup>4</sup> Reference number of turns

## Specifications

Stroke	10.67 ± 0.762 mm
Dielectric Strength	1200 VRMS (23-31 awg); 1500 VRMS (32-33 awg)
Recommended Minimum Heat Sink	Maximum watts dissipated by solenoid are based on an unrestricted flow of air at 20°C. with solenoid mounted on the equivalent of an aluminium plate measuring 314.3 mm square by 3.2 mm thick
Coil Resistance	±5% tolerance on all coil awg
Spring Rate	535.6 Nmm; 4.8 N ±30% preload reference
Weight	652 g
Dimensions	See page E10

## How to Order

Add the coil awg number (0XX) to the part number (for example: to order a 25% duty cycle unit rated at 63 VDC, specify 196659-027).

Please see [www.ledex.com](http://www.ledex.com) (click on Stock Products tab) for our list of stock products available through our distributors.

LINEAR Soft Shift®

## Size 6EPM — Typical Force @ 20°C

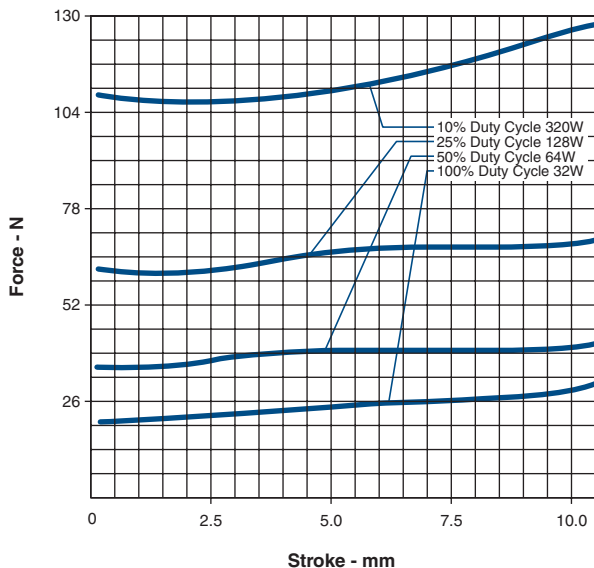

Force values for reference only.

## Size 6EPM — Typical Speed @ No Load, 20°C

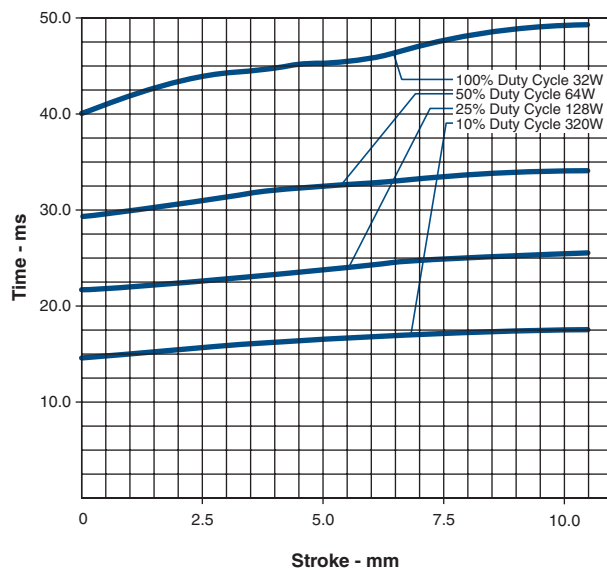

All specifications subject to change without notice.

# Soft Shift® Dimensions

mm

All solenoids are illustrated in energised state

## Size 2EPM

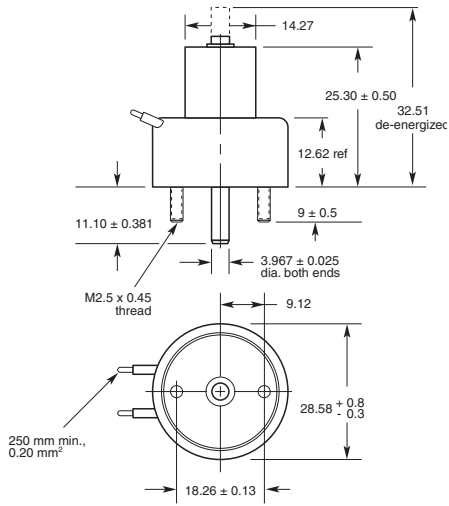

## Size 3EPM

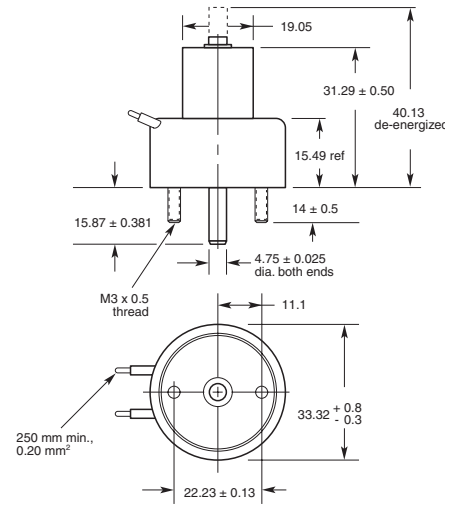

## Size 4EPM

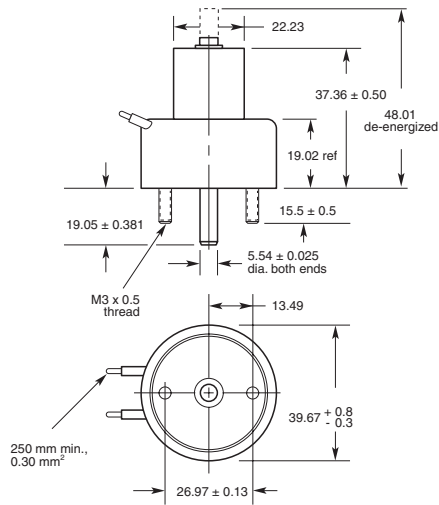

## Size 5EPM

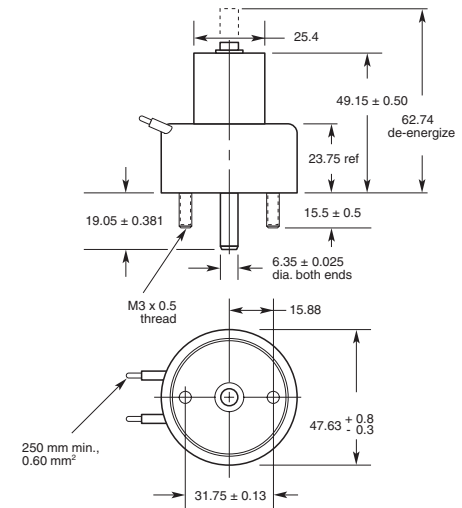

## Size 6EPM

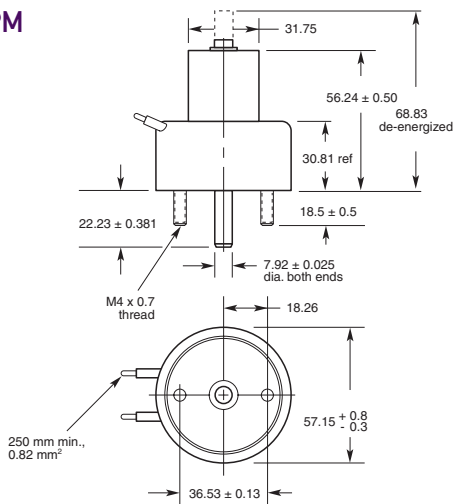

All specifications subject to change without notice.

## Ledex® Tubular Linear Solenoids

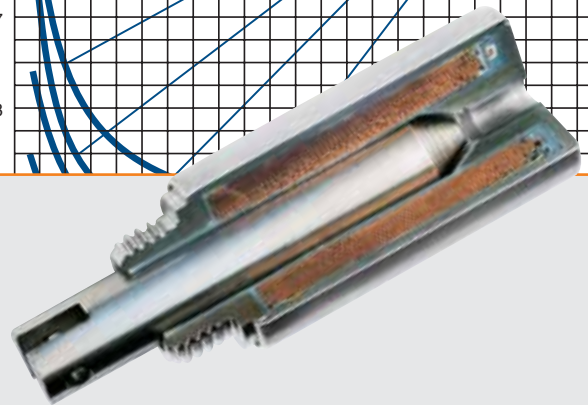
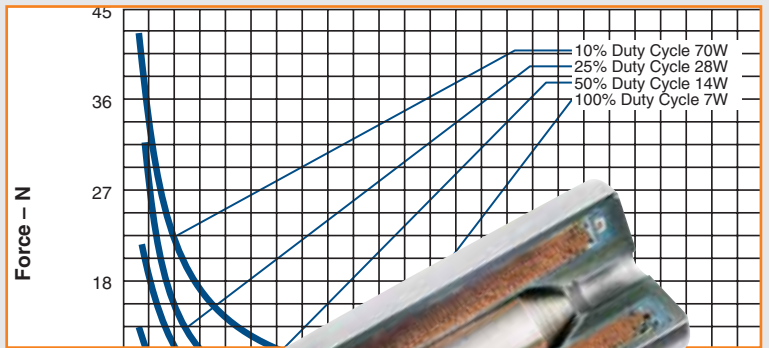

# Ledex® Tubular Solenoids



The Ledex® STA Series of tubular solenoids is available in three sizes of 13, 20 and 26 mm diameter. Both push and pull types are available. Additionally, each size and type is available with a choice of two plunger configurations: flat face and 60°, as well as with or without an anti-rotation bushing. These options offer maximum force for a wide range of applications. The new design also improves performance and provides longer life than previous tubular designs. They offer quiet operation and improved reliability for demanding applications.

## Design Considerations

### Pull versus Push Type

In Pull type solenoids, the plunger is pulled into the solenoid coil when the coil is energised. In Push type solenoids, the same is true, however, the plunger has a shaft extension which then pushes out through a hole in the end of the solenoid case. Please note, however, that the magnetic field cannot be reversed to cause the opposite action to occur.

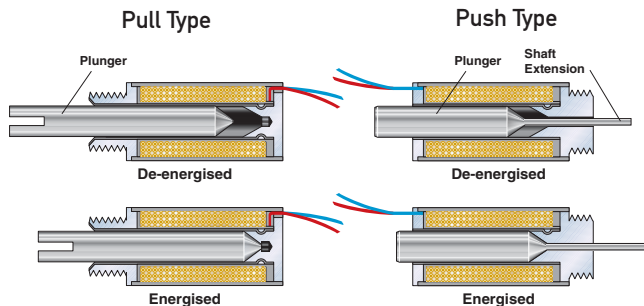

- STA® Series has enhanced design features and improved performance
- Strokes up to 64 mm
- Life rating of 25 million actuations for STA designs
- Push and pull models



All catalogue products manufactured after April 1, 2006 are RoHS Compliant

## Performance Curves

The performance curves in this section serve as guides to determine the solenoid size needed to produce a desired force at a given stroke, duty cycle, and power source. All curves were developed under the following standard test conditions: ambient temperature of 20°C, 65% relative humidity.

## Starting Force

When determining an application's force requirement, apply a 1.5 safety factor. For example: a load requiring 1.0 N of force should utilise a solenoid providing 1.0 N x 1.5 or 1.5 N of force.

## Duty Cycle

Duty cycle is determined by: ON time/(ON + OFF time).

For example: a solenoid is actuated for 30 seconds, then off for 90 seconds.  
 $30 \text{ sec ON} / (30 \text{ Sec ON} + 90 \text{ sec OFF}) = 30/120 = 1/4 \text{ or } 25\% \text{ duty cycle.}$

Ledex tubular solenoids are rated for various duty cycles ranging from continuous to 10% duty.

Note that maximum ON time for a particular application can be a factor which overrides the duty cycle rating. For example, at 25% duty cycle, the maximum ON time for a given Ledex solenoid is 36 seconds. If, however, the solenoid is operated at a cycle rate which enables the unit to return to ambient temperature between ON cycles, then the maximum ON time is extended somewhat. In the above example, this extended ON time is 44 seconds. Maximum ON time ratings are listed on the individual model specification pages.

## Life

When selecting a tubular solenoid, as with any other solenoid style, it is important to consider the effects of heat on life. When used with a constant voltage supply, an increase in coil temperature reduces the work output and the life of the unit. Standard life is 25,000,000 actuations for STA designs.

## Power Requirements

Voltage applied to the solenoid must be matched to the coil wire size for proper operation. Solenoids are catalogued in coil awgs ranging from #23 up to #37 to accommodate your input power.

Refer to the individual model specification pages for coil wire awg recommendations. Many other coil awg sizes are available. Please feel free to contact our application engineering department for availability.

## Tubular Applications

The STA Series is particularly ideal for applications where field service is prohibitive. Its long life and high reliability are definite advantages in applications involving:

- Computer peripherals
- Industrial sewing machines
- Automated teller machines
- Blood analyzers
- Gate mechanisms
- Packaging machinery
- Door interlocks
- Sorting machines
- Glue dispensers
- Laboratory equipment
- Business machines

## STA Construction

The STA is constructed with a low friction nylon bobbin which insures a 25 million actuations life rating on all models.

The problems associated with powdered metal flaking in typical tubular designs is eliminated with the metal-to-plastic bearing surface. In addition, the new design's case is rolled over both ends of the unit for greater shock and vibration integrity, allowing the STA to withstand severe applications in which typical solenoids may come apart.

Both push and pull models offer a built-in combination air gap spacer and plunger stop. This feature eliminates the need for external E-rings and impact washers which typically fail prematurely, as well as get in the way of your attached mechanisms.

All units are provided with 250 mm PVC lead wires as standard, and are rated for a maximum coil temperature of 130°C. UL-approved materials are used in the construction. For higher temperature applications up to 180°C, please consult the factory for alternate materials which are available in some models. Mechanical and electrical ratings may also be affected. Other options include: special plunger configurations, springs, special mounting features, and anti-rotation flats on mounting bushings. Please consult the factory with details

about your application as tooling may apply to some features.

## STA Plunger Configurations

With two standard plunger configurations to choose from, the new STA Series offers stroke lengths up to 18 mm and up to 107 N of force.

### A. Flat Face

For strokes typically less than 1.5 mm, the flat face plunger is recommended with a pull or push force three to five times greater than 60° plungers.



### B. 60° Angle

For longer strokes up to 19 mm, the 60° plunger offers the greatest advantage over the flat face plunger.

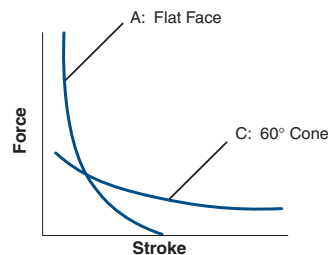

## Size 125M, 150M, 175M Standard Tubular Models for Large Loads

Ledex Size 125M, 150M, and 175M standard tubular models are offered for heavy duty applications requiring larger forces. These standard models are all pull type and offered with 60° plungers. These models feature heavy duty welded mounting brackets, and heavy duty plunger stops to limit plunger travel, provide positive stopping, and keep pole faces from slamming together at the end of stroke.

An impact cushion made of resilient non-magnetic material absorbs energy at the end of the stroke. This cushion also helps eliminate residual magnetism.

Size 125M, 150M, and 175M models are available with other plunger configurations, in push type models, and with other mountings. Please consult the factory as tooling may apply.

# Ledex® Tubular Solenoids Selection

Tubular solenoids are available in seven sizes. The four STA Series sizes are available in both push and pull types.

Use the selection overview chart to determine which size offers the desired performance and mechanical specifications. Refer to the individual size specification pages for complete performance and mechanical data.

● Well-suited for battery operation.



See the "Battery Operated Solenoids" section for complete information.

## Tubular Selection Overview

Size	Solenoid Type	Package Dimension (mm)		Max Stroke (mm)	Nominal Stroke (mm)	Force (N) @ Nominal Stroke and Specified Duty Cycle			
		Dia.	Length			100%	50%	25%	10%
STA 13 x 14	● Pull	13.2	13.9	2.5	1.3	0.80	1.33	2.22	4.45
Mag Latch* 13 x 16	● Pull	13.2	15.7	3.8	1.9	N/A	1.11	2.14	3.34
STA 13 x 14	● Push	13.2	13.9	2.5	1.3	0.80	0.80	1.11	2.67
STA 13 x 27	● Pull	13.2	26.7	12.7	2.5	0.84	1.38	2.49	4.45
STA 13 x 27	● Push	13.2	26.7	12.7	2.5	0.58	1.11	2.14	4.18
STA 20 x 40	● Pull	19.6	39.4	17.8	5.1	2.22	4.45	7.25	11.97
STA 20 x 40	● Push	19.6	39.4	17.8	5.1	1.69	3.56	6.68	12.24
STA 26 x 52	Pull	25.9	52.1	17.8	7.6	4.00	7.79	13.35	23.14
STA 26 x 52	Push	25.9	52.1	17.8	7.6	3.34	8.37	12.90	23.14
STA 125M	Pull	31.8	57.2	19.0	10.2	4.45	8.90	17.80	28.92
STA 150M	Pull	38.1	63.5	19.0	10.2	4.45	11.12	23.14	43.61
STA 175M	Pull	44.4	119.7	63.5	25.4	5.56	11.12	16.69	28.92

All catalogue products manufactured after April 1, 2006 are RoHS Compliant

All data is at 20°C coil temperature. Force outputs degrade with elevated temperatures.

\* See the "Magnetic Latching Solenoids" section for complete information on all our magnetic latching solenoids.

LINEAR Tubular

## How to Use Tubular Performance Charts

- Select one of the four columns which provides the appropriate duty cycle. (For example 50%.)
  - Reading down this column provides a variety of performance and electrical data including maximum on time, watts, and amp turns.
  - Following down the column further into the VDC ratings, select the voltage which most closely matches your supply voltage. (For example, 11.5 for a 12 VDC power supply.)
  - Read across (to the left) to select the awg suffix. (In this example, 32 awg is required, thus to order, specify: 195223-232.
- Note that the digit preceding the awg refers to the plunger configuration and anti-rotation flat selected. Review the STA plunger section on page E3 and on the individual specification page to select the appropriate plunger configuration.

## Performance

Maximum Duty Cycle	100%	50%	25%	10%
Maximum ON Time (sec) when pulsed continuously	∞	50	5	2
Maximum ON Time (sec) for single pulse	∞	140	30	8
Watts (@ 20°C)	4	8	16	40
Ampere Turns (@ 20°C)	497	704	994	1573

Coil Data						
awg (0XX)	Resistance (@20°C)	# Turns	VDC (Nom)	VDC (Nom)	VDC (Nom)	VDC (Nom)
27	1.43	306	2.4	3.4	4.8	7.6
28	1.95	342	2.8	3.9	5.6	8.8
29	3.84	508	3.9	5.5	7.8	12.4
30	5.29	572	4.6	6.5	9.2	14.5
31	9.56	795	6.2	8.8	12.4	19.6
32	16.54	1068	8.1	11.5	16.3	25.7
33	22.60	1194	9.5	13.4	19.0	30.0
34	37.41	1547	12.2	17.3	24.0	39.0
35	60.71	1976	15.6	22.0	31.0	49.0
36	96.19	2475	19.6	28.0	39.0	62.0
37	149.93	3060	24.5	35.0	49.0	77.0

Note: The size 125M, 150M and 175M standard models do not use this plunger configuration and anti-rotation flat suffix system.

All specifications subject to change without notice.

# Ledex® Tubular Solenoids Design Modifications

## Options and Modified Designs

Even though many solenoid designs are in stock and available via distribution, our customers often require a product with unique features or performance capabilities. In fact, almost 80% of all solenoids that we make are either modified or custom built to meet our customers' exact application requirements.

So, if you don't find what you're looking for in the catalogue, give us a call to discuss your needs with one of our application engineers.

## Typical Examples of Custom Features



Elliptical



Clevis-grooved

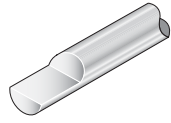

Flatted



Clevis-tongue

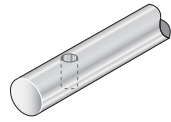

Drilled hole

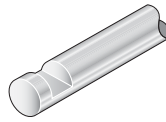

Notched

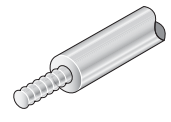

Threaded rod



Tapped hole

# STA® Pull Tubular Solenoids — 13 mm Dia. x 14 mm

Part Number: 195220 - X XX

All catalogue products manufactured after April 1, 2006 are RoHS Compliant

Coil AWG Number  
(from performance chart below)

Plunger Configurations and anti-rotation flat on mounting  
2 60° plunger without anti-rotation flat  
6 60° plunger with anti-rotation flat

Well-suited for battery operation.



See the "Battery Operated Solenoids" section for complete information.

## Performance

Maximum Duty Cycle	100%	50%	25%	10%
Maximum ON Time (sec) when pulsed continuously <sup>1</sup>	∞	50	5	2
Maximum ON Time (sec) for single pulse <sup>2</sup>	∞	140	30	8
Watts (@ 20°C)	3	6	12	30
Ampere Turns (@ 20°C)	268	379	536	847

### Coil Data

awg (0XX) <sup>3</sup>	Resistance (@20°C)	# Turns <sup>4</sup>	VDC (Nom)	VDC (Nom)	VDC (Nom)	VDC (Nom)
27	0.48	108	1.2	1.7	2.4	3.8
28	0.67	123	1.5	2.1	2.9	4.6
29	1.33	184	1.9	2.7	3.9	6.1
30	1.80	204	2.4	3.3	4.7	7.5
31	3.33	290	3.1	4.4	6.2	9.7
32	4.57	325	3.8	5.3	7.5	11.9
33	7.80	432	4.8	6.8	9.7	15.3
34	13.10	567	6.2	8.8	12.4	19.6
35	17.80	630	7.6	11.0	15.0	24.0
36	29.05	808	9.6	14.0	19.0	30.0
37	45.70	1008	12.2	17.0	24.0	38.0

- <sup>1</sup> Continuously pulsed at stated watts and duty cycle
- <sup>2</sup> Single pulse at stated watts (with coil at ambient room temperature 20°C)
- <sup>3</sup> Other coil awg sizes available — please consult factory
- <sup>4</sup> Reference number of turns

## Specifications

Dielectric Strength	500 VRMS
Recommended Minimum Heat Sink	Maximum watts dissipated by solenoid are based on an unrestricted flow of air at 20°C, with solenoid mounted on the equivalent of an aluminium plate measuring 51 mm square by 3.2 mm thick
Coil Resistance	±5% tolerance
Weight	14.5 g
Dimensions	See page F27

## How to Order

Add the plunger configuration, anti-rotation flat number, and the coil awg number to the part number (for example: to order a unit with a 60° plunger configuration without an anti-rotation flat rated for 5 VDC at 25% duty cycle, specify 195220-230).

Please see [www.ledex.com](http://www.ledex.com) (click on Stock Products tab) for our list of stock products available through our distributors.

All specifications subject to change without notice.

# STA® Pull Tubular Solenoids — 13 mm Dia. x 14 mm

## Pull Tubular Solenoid – 13 mm Dia. x 14 mm – 60° Plunger

Typical Force @ 20°C

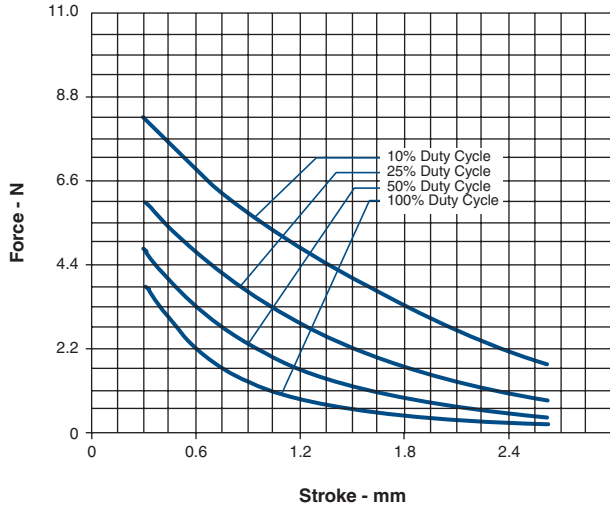

Typical Speed @ No Load, 20°C

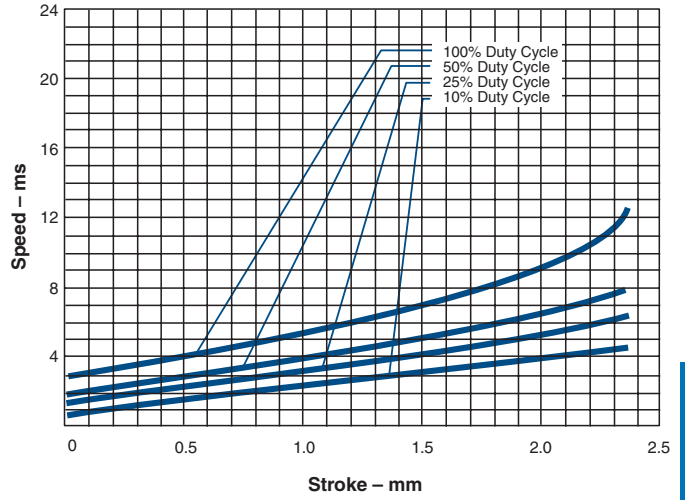

LINEAR Tubular

All specifications subject to change without notice.

# STA® Pull Magnetic Latching Solenoid — 13 mm Dia. x 16 mm

Part Number: 151094 - X XX

All catalogue products manufactured after April 1, 2006 are RoHS Compliant

Coil AWG Number  
(from performance chart below)

Plunger Configurations and anti-rotation flat on mounting  
 1 Flat Face plunger without anti-rotation flat on mounting  
 2 60° plunger without anti-rotation flat on mounting  
 5 Flat Face plunger with anti-rotation flat on mounting  
 6 60° plunger with anti-rotation flat on mounting

Well-suited for battery operation.



See the "Battery Operated Solenoids" section for complete information.

## Coil Polarity

Latch: A+ B-  
Unlatch: A- B+

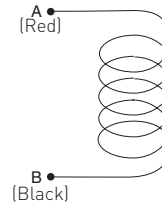

LINEAR Tubular

## Performance

	Unlatched			
	Voltage	50%	25%	10%
Maximum Duty Cycle				
Maximum ON Time (sec) when pulsed continuously <sup>1</sup>	n/a	50	5	2
Watts (@ 20°C)	3	6	12	30
Ampere Turns (@ 20°C)	268	379	536	847

### Coil Data

awg (0XX) <sup>2</sup>	Resistance (@20°C)	# Turns <sup>3</sup>	Unlatched VDC	VDC (Nom)	VDC (Nom)	VDC (Nom)
27	0.48	108	1.2	1.7	2.4	3.8
28	0.67	123	1.5	2.1	2.9	4.6
29	1.33	184	1.9	2.7	4.0	6.1
30	1.80	204	2.4	3.3	4.7	7.5
31	3.33	290	3.1	4.4	6.2	9.7
32	4.57	325	3.8	5.3	7.5	11.9
33	7.80	432	4.8	6.8	9.7	15.3
34	13.10	567	6.2	8.8	12.4	20.0
35	17.80	630	7.6	11.0	15.0	24.0
36	29.05	808	9.6	14.0	19.0	30.0
37	45.70	1008	12.2	17.0	24.0	38.0

- <sup>1</sup> Continuously pulsed at stated watts and duty cycle  
<sup>2</sup> Other coil awg sizes available — please consult factory  
<sup>3</sup> Reference number of turns

## Specifications

Operation	Pull
Dielectric Strength	500 VRMS
Recommended Minimum Heat Sink	Maximum watts dissipated by solenoid are based on an unrestricted flow of air at 20°C, with solenoid mounted on the equivalent of an aluminium plate measuring 51 mm square by 3.2 mm thick
Unlatch Voltage	See schematic and coil data
Magnet Hold Force	2 N (with return spring)
Coil Insulation	Class "B"; 130°C max. temperature standard. Other temperature classes are available.
Coil Termination	25 mm PVC lead wires
Plunger Pole Face	60° with return spring (other options available upon request)
Plunger Weight	2.6 g
Spring Force	9.8 N; 1.2 N latched position
Total Weight	14.7 g
Dimensions	See page F27

## How to Order

Add the plunger configuration, anti-rotation flat number, and the coil awg number to the part number (for example: to order a 60° plunger unit without an anti-rotation flat, rated for 5 VDC at 25% duty cycle, specify 151094-250).

Please see [www.ledex.com](http://www.ledex.com) (click on Stock Products tab) for our list of stock products available through our distributors.

All specifications subject to change without notice.

# STA<sup>®</sup> Pull Magnetic Latching Solenoid — 13 mm Dia. x 16 mm

## Pull Tubular Solenoid – 13 mm Dia. x 16 mm – 60° Plunger

Typical Force @ 20°C (Net, with Spring)

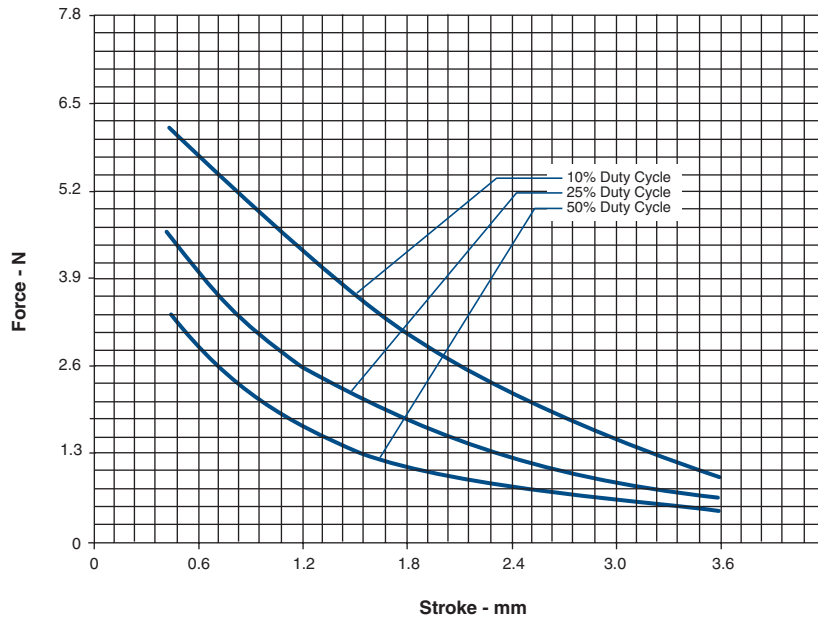

LINEAR Tubular

All specifications subject to change without notice.

# STA® Push Tubular Solenoids — 13 mm Dia. x 14 mm

Part Number: 195221-**X****XX**

All catalogue products manufactured after April 1, 2006 are RoHS Compliant

Coil AWG Number  
(from performance chart below)

Plunger Configurations and anti-rotation flat on mounting  
2 60° plunger without anti-rotation flat  
6 60° plunger with anti-rotation flat

- Well-suited for battery operation.



See the "Battery Operated Solenoids" section for complete information.

## Performance

Maximum Duty Cycle	100%	50%	25%	10%
Maximum ON Time (sec) when pulsed continuously <sup>1</sup>	∞	50	5	2
Maximum ON Time (sec) for single pulse <sup>2</sup>	∞	140	30	8
Watts (@ 20°C)	3	6	12	30
Ampere Turns (@ 20°C)	268	379	536	847

### Coil Data

awg (0XX) <sup>3</sup>	Resistance (@20°C)	# Turns <sup>4</sup>	VDC (Nom)	VDC (Nom)	VDC (Nom)	VDC (Nom)
27	0.48	108	1.2	1.7	2.4	3.8
28	0.67	123	1.5	2.1	2.9	4.6
29	1.33	184	1.9	2.7	3.9	6.1
30	1.80	204	2.4	3.3	4.7	7.5
31	3.33	290	3.1	4.4	6.2	9.7
32	4.57	325	3.8	5.3	7.5	11.9
33	7.80	432	4.8	6.8	9.7	15.3
34	13.10	567	6.2	8.8	12.4	19.6
35	17.80	630	7.6	11.0	15.0	24.0
36	29.05	808	9.6	14.0	19.0	30.0
37	45.70	1008	12.2	17.0	24.0	38.0

- Continuously pulsed at stated watts and duty cycle
- Single pulse at stated watts (with coil at ambient room temperature 20°C)
- Other coil awg sizes available — please consult factory
- Reference number of turns

## Specifications

Dielectric Strength	500 VRMS
Recommended Minimum Heat Sink	Maximum watts dissipated by solenoid are based on an unrestricted flow of air at 20°C, with solenoid mounted on the equivalent of an aluminium plate measuring 51 mm square by 3.2 mm thick
Coil Resistance	±5% tolerance
Weight	14.5 g
Dimensions	See page F27

## How to Order

Add the plunger configuration, anti-rotation flat number, and the coil awg number to the part number (for example: to order a unit with a 60° plunger configuration without an anti-rotation flat rated for 5 VDC at 25% duty cycle, specify 195221-230).

Please see [www.ledex.com](http://www.ledex.com) (click on Stock Products tab) for our list of stock products available through our distributors.

All specifications subject to change without notice.

# STA® Push Tubular Solenoids — 13 mm Dia. x 14 mm

## Push Tubular Solenoid – 13 mm Dia. x 14 mm – 60° Plunger

Typical Force @ 20°C

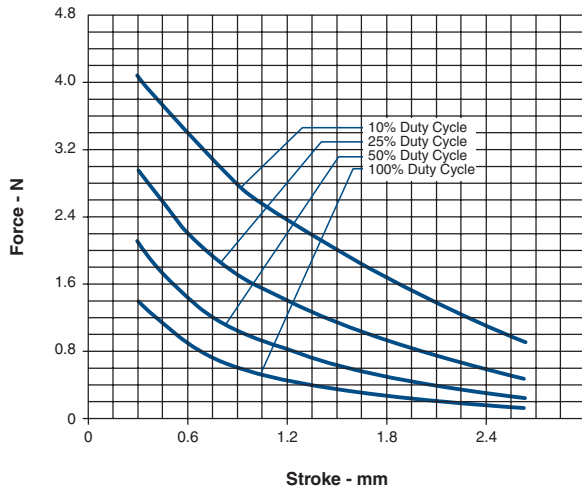

Typical Speed @ No Load, 20°C

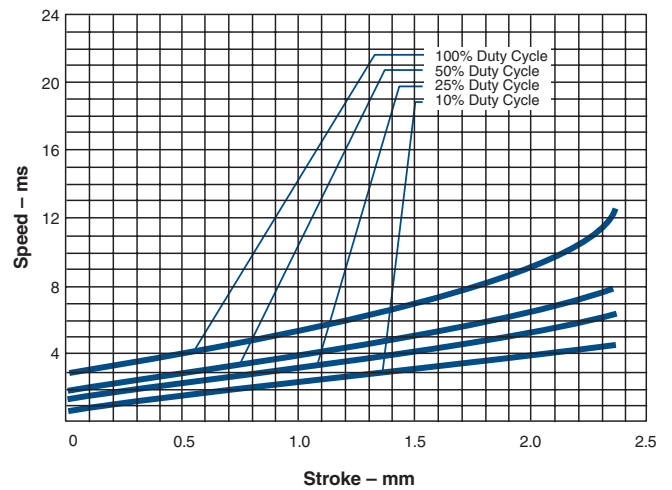

LINEAR Tubular

All specifications subject to change without notice.

# STA® Pull Tubular Solenoids — 13 mm Dia. x 27 mm

Part Number: 195222 - X XX

All catalogue products manufactured after April 1, 2006 are RoHS Compliant

Coil AWG Number  
(from performance chart below)

Plunger Configurations and anti-rotation flat on mounting

- 1 Flat face plunger without anti-rotation flat
- 2 60° plunger without anti-rotation flat
- 5 Flat face plunger with anti-rotation flat
- 6 60° plunger with anti-rotation flat

- Well-suited for battery operation.



See the "Battery Operated Solenoids" section for complete information.

## Performance

Maximum Duty Cycle	100%	50%	25%	10%
Maximum ON Time (sec) when pulsed continuously <sup>1</sup>	∞	50	5	2
Maximum ON Time (sec) for single pulse <sup>2</sup>	∞	140	30	8
Watts (@ 20°C)	4	8	16	40
Ampere Turns (@ 20°C)	497	704	994	1573

### Coil Data

awg (0XX) <sup>3</sup>	Resistance (@20°C)	# Turns <sup>4</sup>	VDC (Nom)	VDC (Nom)	VDC (Nom)	VDC (Nom)
27	1.43	306	2.4	3.4	4.8	7.6
28	1.95	342	2.8	3.9	5.6	8.8
29	3.84	508	3.9	5.5	7.8	12.4
30	5.29	572	4.6	6.5	9.2	14.5
31	9.56	795	6.2	8.8	12.4	19.6
32	16.54	1068	8.1	11.5	16.3	25.7
33	22.60	1194	9.5	13.4	19.0	30.0
34	37.41	1547	12.2	17.3	24.0	39.0
35	60.71	1976	15.6	22.0	31.0	49.0
36	96.19	2475	19.6	28.0	39.0	62.0
37	149.93	3060	24.5	35.0	49.0	77.0

- <sup>1</sup> Continuously pulsed at stated watts and duty cycle
- <sup>2</sup> Single pulse at stated watts (with coil at ambient room temperature 20°C)
- <sup>3</sup> Other coil awg sizes available — please consult factory
- <sup>4</sup> Reference number of turns

## Specifications

Dielectric Strength	500 VRMS
Recommended Minimum Heat Sink	Maximum watts dissipated by solenoid are based on an unrestricted flow of air at 20°C. with solenoid mounted on the equivalent of an aluminium plate measuring 51 mm square by 3.2 mm thick
Coil Resistance	±5% tolerance
Holding Force	Flat Face: 5.3 N @ 20°C 60°: 4.0 N @ 20°C
Weight	24.7 g
Plunger Weight	4.5 g
Dimensions	See page F28

## How to Order

Add the plunger configuration, anti-rotation flat number, and the coil awg number to the part number (for example: to order a unit with a 60° plunger configuration without an anti-rotation flat rated for 5 VDC at 25% duty cycle, specify 195222-227.

Please see [www.ledex.com](http://www.ledex.com) (click on Stock Products tab) for our list of stock products available through our distributors.

All specifications subject to change without notice.

# STA® Pull Tubular Solenoids — 13 mm Dia. x 27 mm

## Pull Tubular Solenoid – 13 mm dia. x 27 mm – Flat Face Plunger

Typical Force @ 20°C

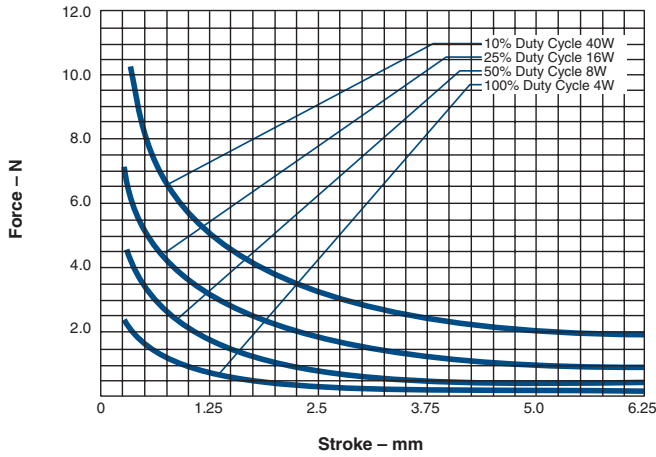

Typical Speed @ No Load, 20°C

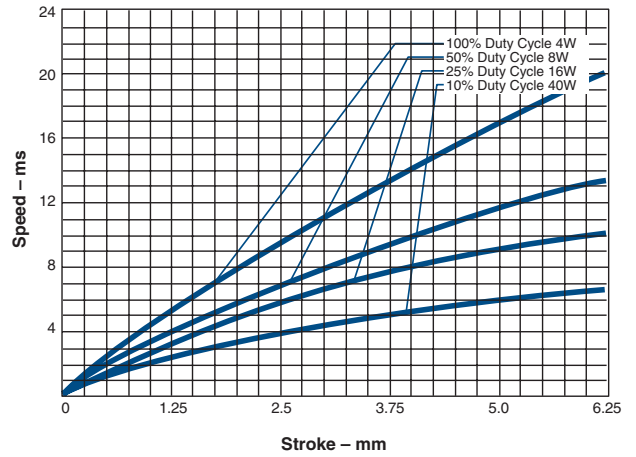

## Pull Tubular Solenoid – 13 mm dia. x 27 mm – 60° Plunger

Typical Force @ 20°C

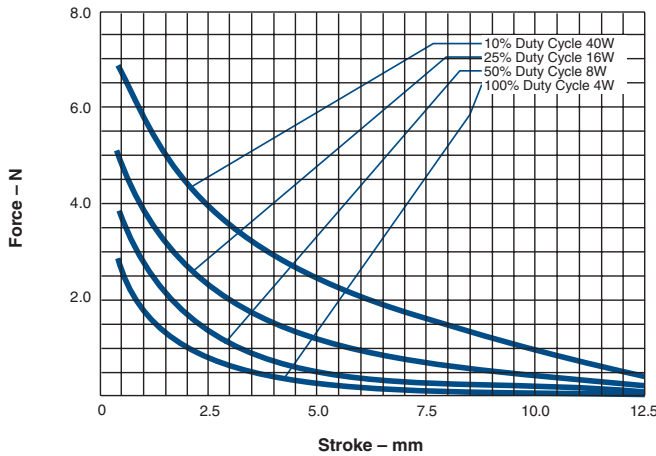

Typical Speed @ No Load, 20°C

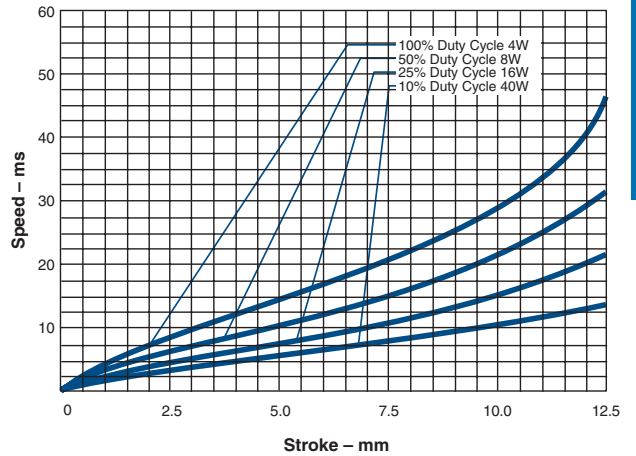

LINEAR Tubular

All specifications subject to change without notice.

# STA® Push Tubular Solenoids — 13 mm Dia. x 27 mm

Part Number: 195223 - X XX

All catalogue products manufactured after April 1, 2006 are RoHS Compliant

Coil AWG Number  
(from performance chart below)

Plunger Configurations and anti-rotation flat on mounting

- 1 Flat face plunger without anti-rotation flat
- 2 60° plunger without anti-rotation flat
- 5 Flat face plunger with anti-rotation flat
- 6 60° plunger with anti-rotation flat

- Well-suited for battery operation.



See the "Battery Operated Solenoids" section for complete information.

## Performance

Maximum Duty Cycle	100%	50%	25%	10%
Maximum ON Time (sec) when pulsed continuously <sup>1</sup>	∞	50	5	2
Maximum ON Time (sec) for single pulse <sup>2</sup>	∞	140	30	8
Watts (@ 20°C)	4	8	16	40
Ampere Turns (@ 20°C)	497	704	994	1573

### Coil Data

awg (0XX) <sup>3</sup>	Resistance (@20°C)	# Turns <sup>4</sup>	VDC (Nom)	VDC (Nom)	VDC (Nom)	VDC (Nom)
27	1.43	306	2.4	3.4	4.8	7.6
28	1.95	342	2.8	3.9	5.6	8.8
29	3.84	508	3.9	5.5	7.8	12.4
30	5.29	572	4.6	6.5	9.2	14.5
31	9.56	795	6.2	8.8	12.4	19.6
32	16.54	1068	8.1	11.5	16.3	25.7
33	22.60	1194	9.5	13.4	19.0	30.0
34	37.41	1547	12.2	17.3	24.0	39.0
35	60.71	1976	15.6	22.0	31.0	49.0
36	96.19	2475	19.6	28.0	39.0	62.0
37	149.93	3060	24.5	35.0	49.0	77.0

- <sup>1</sup> Continuously pulsed at stated watts and duty cycle
- <sup>2</sup> Single pulse at stated watts (with coil at ambient room temperature 20°C)
- <sup>3</sup> Other coil awg sizes available — please consult factory
- <sup>4</sup> Reference number of turns

## Specifications

Dielectric Strength	500 VRMS
Recommended Minimum Heat Sink	Maximum watts dissipated by solenoid are based on an unrestricted flow of air at 20°C, with solenoid mounted on the equivalent of an aluminium plate measuring 51 mm square by 3.2 mm thick
Coil Resistance	±5% tolerance
Holding Force	Flat Face: 4.5 N @ 20°C 60°: 3.2 N @ 20°C
Weight	25.2 g
Plunger Weight	3.1 g
Dimensions	See page F28

## How to Order

Add the plunger configuration, anti-rotation flat number and the coil awg number to the part number (for example: to order a unit with a 60° plunger configuration without anti-rotation rated for 5 VDC at 25% duty cycle, specify 195223-227).

Please see [www.ledex.com](http://www.ledex.com) (click on Stock Products tab) for our list of stock products available through our distributors.

All specifications subject to change without notice.

# STA® Push Tubular Solenoids — 13 mm Dia. x 27 mm

## Push Tubular Solenoid – 13 mm dia. x 27 mm – Flat Face Plunger

Typical Force @ 20°C

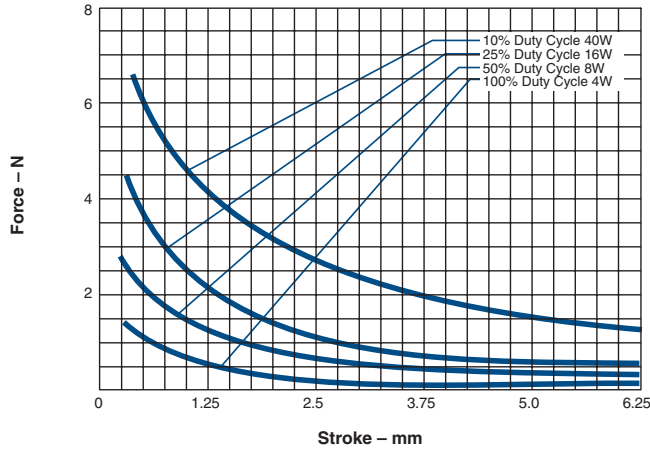

Typical Speed @ No Load, 20°C

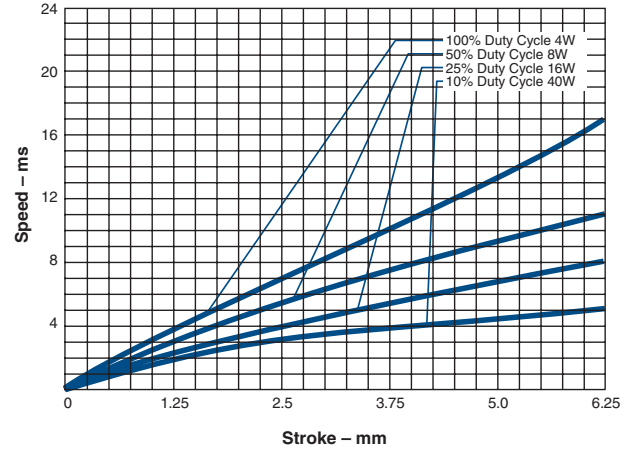

## Push Tubular Solenoid – 13 mm dia. x 27 mm – 60° Plunger

Typical Force @ 20°C

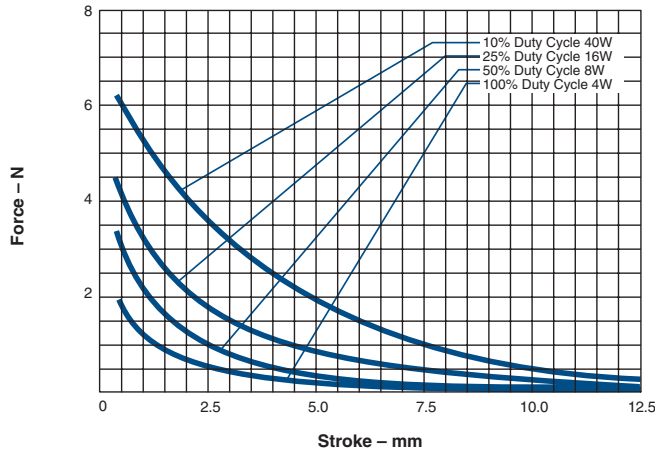

Typical Speed @ No Load, 20°C

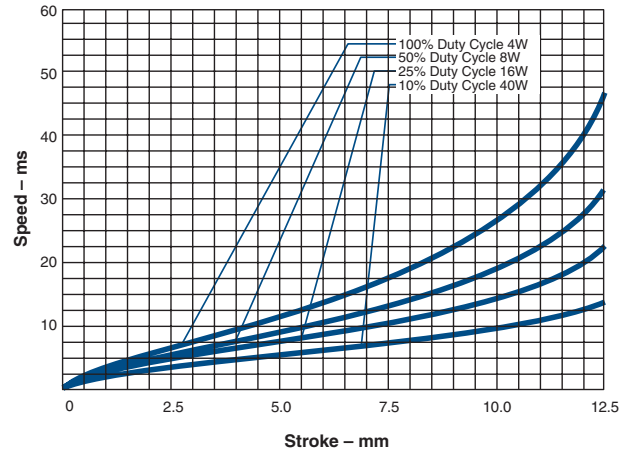

LINEAR Tubular

All specifications subject to change without notice.

# STA® Pull Tubular Solenoids — 20 mm Dia. x 40 mm

Part Number: 195224 - **X** **XX**

All catalogue products manufactured after April 1, 2006 are RoHS Compliant

Coil AWG Number  
(from performance chart below)

Plunger Configurations and anti-rotation flat on mounting

- 1 Flat face plunger without anti-rotation flat
- 2 60° plunger without anti-rotation flat
- 5 Flat face plunger with anti-rotation flat
- 6 60° plunger with anti-rotation flat

- Well-suited for battery operation.



See the "Battery Operated Solenoids" section for complete information.

## Performance

Maximum Duty Cycle	100%	50%	25%	10%
Maximum ON Time (sec) when pulsed continuously <sup>1</sup>	∞	230	25	6
Maximum ON Time (sec) for single pulse <sup>2</sup>	∞	265	63	15
Watts (@ 20°C)	7	14	28	70
Ampere Turns (@ 20°C)	855	1200	1700	2700

### Coil Data

awg (0XX) <sup>3</sup>	Resistance (@20°C)	# Turns <sup>4</sup>	VDC (Nom)	VDC (Nom)	VDC (Nom)	VDC (Nom)
24	1.10	330	2.7	3.8	5.6	8.8
25	2.13	488	3.9	5.5	7.7	12.2
26	2.90	544	4.5	6.4	9.0	14.2
27	5.27	760	6.1	8.6	12.1	19.2
28	9.15	1026	8.0	11.3	16.0	25.0
29	12.50	1146	9.4	13.2	18.7	30.0
30	20.70	1491	12.0	17.0	24.0	38.0
31	33.60	1904	15.0	22.0	31.0	48.0
32	53.50	2394	19.4	27.0	39.0	61.0
33	83.50	2970	24.0	34.0	48.0	76.0

- <sup>1</sup> Continuously pulsed at stated watts and duty cycle
- <sup>2</sup> Single pulse at stated watts (with coil at ambient room temperature 20°C)
- <sup>3</sup> Other coil awg sizes available — please consult factory
- <sup>4</sup> Reference number of turns

## Specifications

Dielectric Strength	1000 VRMS
Recommended Minimum Heat Sink	Maximum watts dissipated by solenoid are based on an unrestricted flow of air at 20°C, with solenoid mounted on the equivalent of an aluminium plate measuring 76 mm square by 3.2 mm thick
Coil Resistance	±5% tolerance
Holding Force	Flat Face: 23.3 N @ 20°C 60°: 12.8 N @ 20°C
Weight	83.6 g
Plunger Weight	20.1 g
Dimensions	See page F29

## How to Order

Add the plunger number and the coil awg number to the part number (for example: to order a unit with a 60° plunger configuration without an anti-rotation flat rated for 12 VDC at 25% duty cycle, specify 195224-227.

Please see [www.ledex.com](http://www.ledex.com) (click on Stock Products tab) for our list of stock products available through our distributors.

All specifications subject to change without notice.

# STA® Pull Tubular Solenoids — 20 mm Dia. x 40 mm

## Pull Tubular Solenoid – 20 mm dia. x 40 mm – Flat Face Plunger

Typical Force @ 20°C

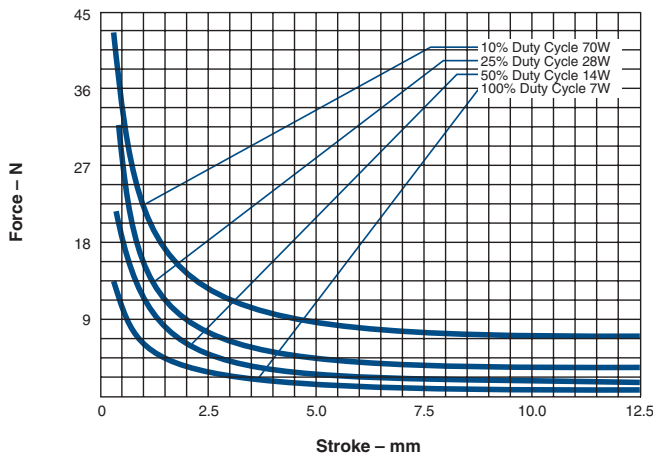

Typical Speed @ No Load, 20°C

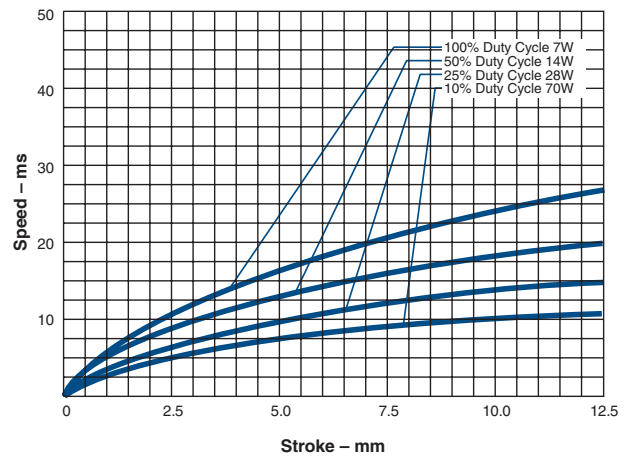

## Pull Tubular Solenoid – 20 mm dia. x 40 mm – 60° Plunger

Typical Force @ 20°C

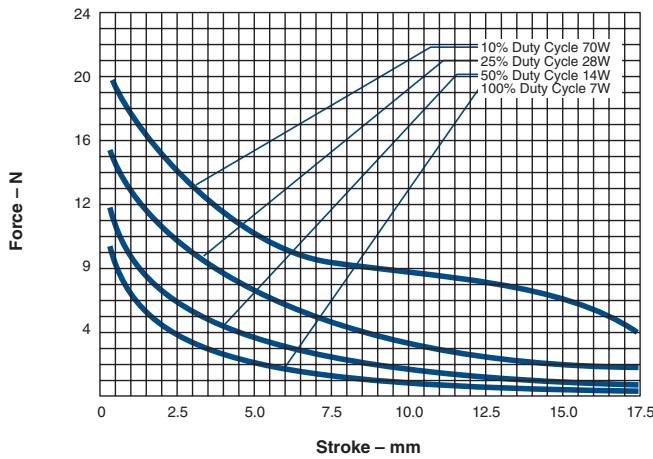

Typical Speed @ No Load, 20°C

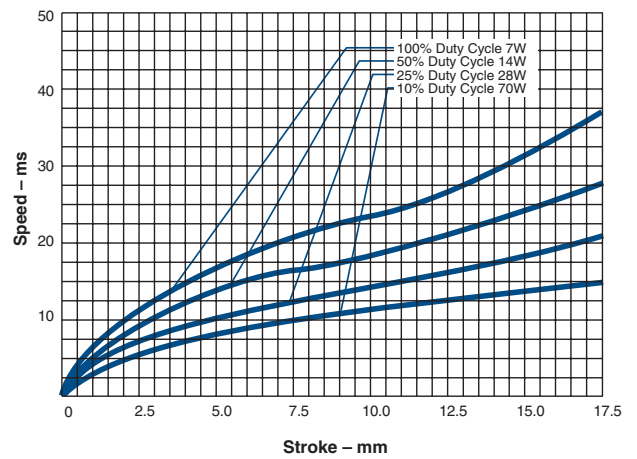

LINEAR Tubular

All specifications subject to change without notice.

# STA® Push Tubular Solenoids — 20 mm Dia. x 40 mm

Part Number: 195225 - X XX

All catalogue products manufactured after April 1, 2006 are RoHS Compliant

Coil AWG Number  
(from performance chart below)

Plunger Configurations and anti-rotation flat on mounting

- 1 Flat face plunger without anti-rotation flat
- 2 60° plunger without anti-rotation flat
- 5 Flat face plunger with anti-rotation flat
- 6 60° plunger with anti-rotation flat

- Well-suited for battery operation.



See the "Battery Operated Solenoids" section for complete information.

## Performance

Maximum Duty Cycle	100%	50%	25%	10%
Maximum ON Time (sec) when pulsed continuously <sup>1</sup>	∞	230	25	6
Maximum ON Time (sec) for single pulse <sup>2</sup>	∞	265	63	15
Watts @ 20°C	7	14	28	70
Ampere Turns @ 20°C	855	1200	1700	2700

### Coil Data

awg (0XX) <sup>3</sup>	Resistance (@20°C)	# Turns <sup>4</sup>	VDC (Nom)	VDC (Nom)	VDC (Nom)	VDC (Nom)
24	1.10	330	2.7	3.8	5.6	8.8
25	2.13	488	3.9	5.5	7.7	12.2
26	2.90	544	4.5	6.4	9.0	14.2
27	5.27	760	6.1	8.6	12.1	19.2
28	9.15	1026	8.0	11.3	16.0	25.0
29	12.50	1146	9.4	13.2	18.7	30.0
30	20.70	1491	12.0	17.0	24.0	38.0
31	33.60	1904	15.0	22.0	31.0	48.0
32	53.50	2394	19.4	27.0	39.0	61.0
33	83.50	2970	24.0	34.0	48.0	76.0

- <sup>1</sup> Continuously pulsed at stated watts and duty cycle
- <sup>2</sup> Single pulse at stated watts (with coil at ambient room temperature 20°C)
- <sup>3</sup> Other coil awg sizes available — please consult factory
- <sup>4</sup> Reference number of turns

## Specifications

Dielectric Strength	1000 VRMS
Recommended Minimum Heat Sink	Maximum watts dissipated by solenoid are based on an unrestricted flow of air at 20°C, with solenoid mounted on the equivalent of an aluminium plate measuring 76 mm square by 3.2 mm thick
Coil Resistance	±5% tolerance
Holding Force	Flat Face: 22.0 N @ 20°C 60°: 12.7 N @ 20°C
Weight	87.3 g
Plunger Weight	15.0 g
Dimensions	See page F29

## How to Order

Add the plunger number and the coil awg number to the part number (for example: to order a unit with a 60° plunger configuration without an anti-rotation flat rated for 12 VDC at 25% duty cycle, specify 195225-227.

Please see [www.ledex.com](http://www.ledex.com) (click on Stock Products tab) for our list of stock products available through our distributors.

All specifications subject to change without notice.

# STA® Push Tubular Solenoids — 20 mm Dia. x 40 mm

## Push Tubular Solenoid – 20 mm dia. x 40 mm – Flat Face Plunger

Typical Force @ 20°C

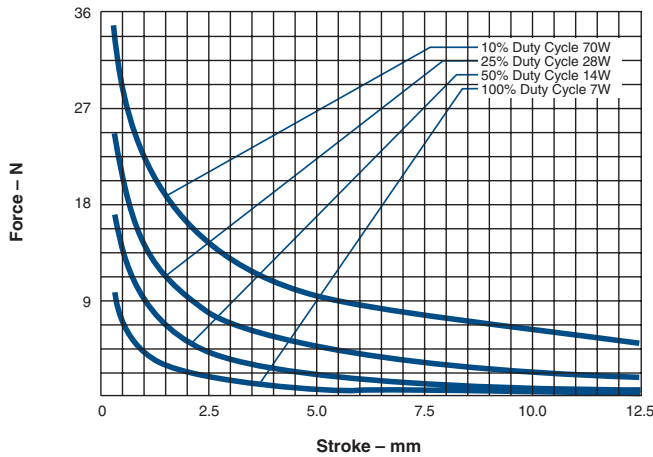

Typical Speed @ No Load, 20°C

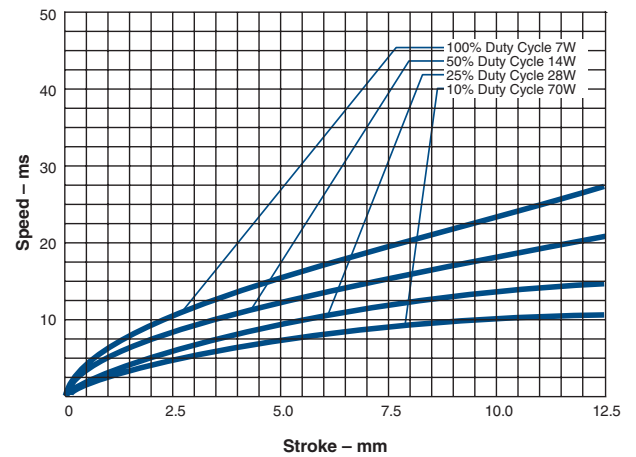

## Push Tubular Solenoid – 20 mm dia. x 40 mm – 60° Plunger

Typical Force @ 20°C

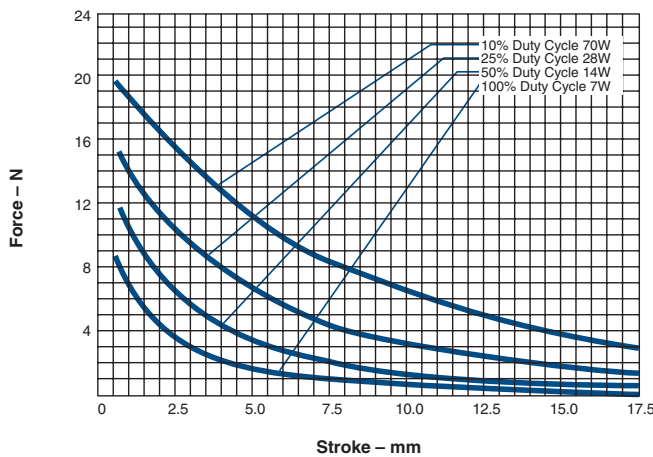

Typical Speed @ No Load, 20°C

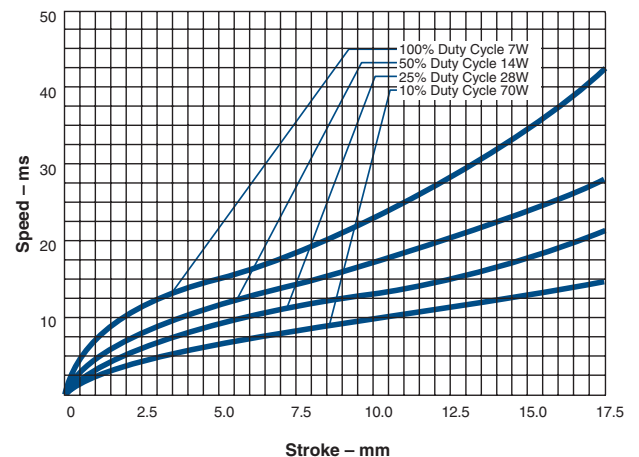

LINEAR Tubular

All specifications subject to change without notice.

# STA® Pull Tubular Solenoids — 26 mm Dia. x 52 mm

Part Number: 195226 - **X** **XX**

All catalogue products manufactured after April 1, 2006 are RoHS Compliant

Coil AWG Number  
(from performance chart below)

Plunger Configurations and anti-rotation flat on mounting

- 1 Flat face plunger without anti-rotation flat
- 2 60° plunger without anti-rotation flat
- 5 Flat face plunger with anti-rotation flat
- 6 60° plunger with anti-rotation flat

## Performance

Maximum Duty Cycle	100%	50%	25%	10%
Maximum ON Time (sec) when pulsed continuously <sup>1</sup>	∞	360	32	8
Maximum ON Time (sec) for single pulse <sup>2</sup>	∞	470	120	32
Watts (@ 20°C)	10	20	40	100
Ampere Turns (@ 20°C)	1166	1649	2332	3688

### Coil Data

awg (0XX) <sup>3</sup>	Resistance (@20°C)	# Turns <sup>4</sup>	VDC (Nom)	VDC (Nom)	VDC (Nom)	VDC (Nom)
23	1.96	536	4.4	6.3	8.9	14.0
24	2.69	600	5.2	7.3	10.4	16.4
25	4.89	840	7.0	9.9	14.0	22.0
26	8.44	1128	9.2	13.0	18.4	29.0
27	11.50	1260	10.7	15.2	21.0	34.0
28	19.20	1645	13.8	19.6	28.0	44.0
29	31.20	2104	17.7	25.0	35.0	56.0
30	49.60	2646	22.0	31.0	45.0	70.0
31	77.40	3280	28.0	39.0	56.0	88.0
32	119.00	4026	35.0	49.0	69.0	109.0
33	202.00	5317	45.0	64.0	90.0	142.0

- <sup>1</sup> Continuously pulsed at stated watts and duty cycle
- <sup>2</sup> Single pulse at stated watts (with coil at ambient room temperature 20°C)
- <sup>3</sup> Other coil awg sizes available — please consult factory
- <sup>4</sup> Reference number of turns

## Specifications

Dielectric Strength	1000 VRMS
Recommended Minimum Heat Sink	Maximum watts dissipated by solenoid are based on an unrestricted flow of air at 20°C, with solenoid mounted on the equivalent of an aluminium plate measuring 102 mm square by 3.2 mm thick
Coil Resistance	±5% tolerance
Holding Force	Flat Face: 61.5 N @ 20°C 60°: 29.4 N @ 20°C
Weight	197.3 g
Plunger Weight	45.4 g
Dimensions	See page F30

## How to Order

Add the plunger configuration number and the coil awg number to the part number (for example: to order a unit with a 60° plunger rated for 21 VDC at 25% duty cycle, specify 195226-227.

Please see [www.ledex.com](http://www.ledex.com) (click on Stock Products tab) for our list of stock products available through our distributors.

All specifications subject to change without notice.

# STA® Pull Tubular Solenoids — 26 mm Dia. x 52 mm

## Pull Tubular Solenoid – 26 mm dia. x 52 mm – Flat Face Plunger

Typical Force @ 20°C

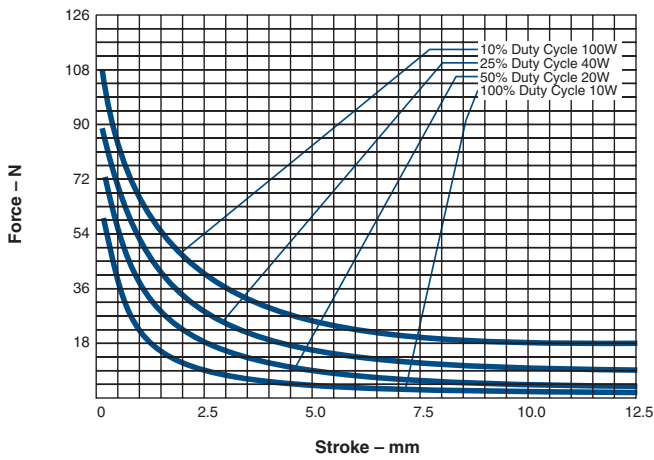

Typical Speed @ No Load, 20°C

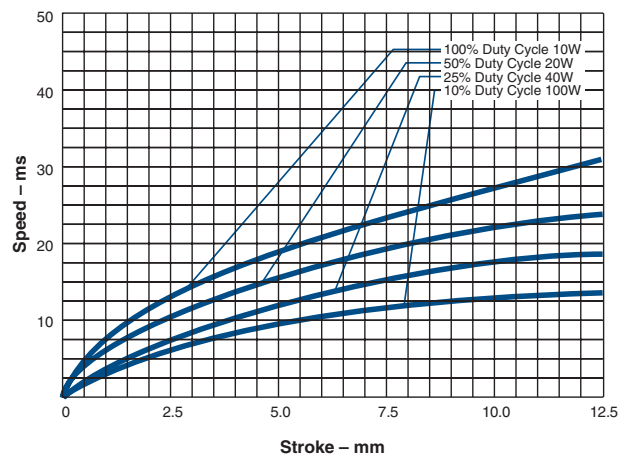

## Pull Tubular Solenoid – 26 mm dia. x 52 mm – 60° Plunger

Typical Force @ 20°C

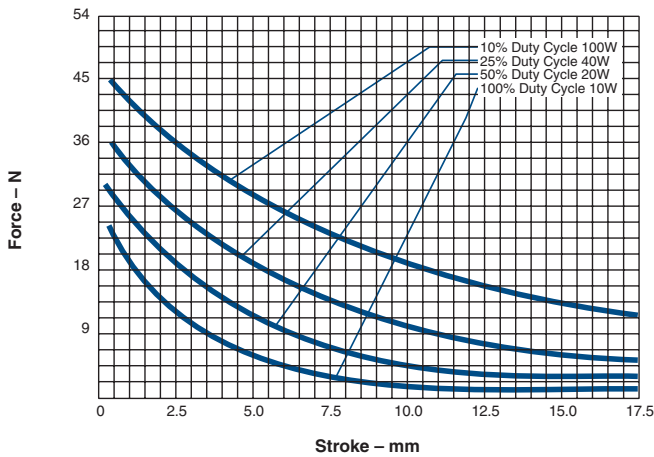

Typical Speed @ No Load, 20°C

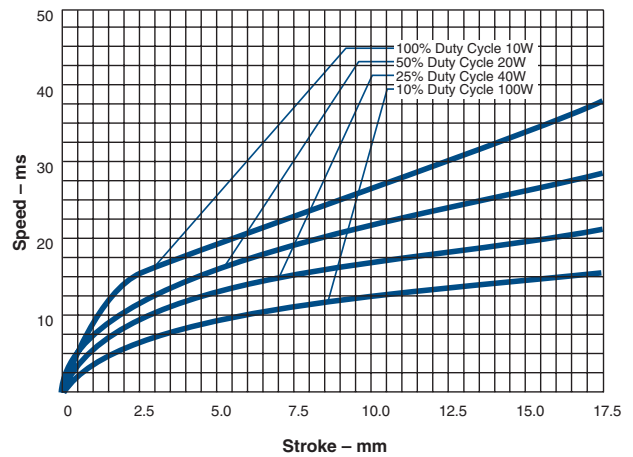

LINEAR Tubular

All specifications subject to change without notice.

# STA® Push Tubular Solenoids — 26 mm Dia. x 52 mm

Part Number: 195227 - X XX

All catalogue products manufactured after April 1, 2006 are RoHS Compliant

Coil AWG Number  
(from performance chart below)

Plunger Configurations and anti-rotation flat on mounting

- 1 Flat face plunger without anti-rotation flat
- 2 60° plunger without anti-rotation flat
- 5 Flat face plunger with anti-rotation flat
- 6 60° plunger with anti-rotation flat

## Performance

	100%	50%	25%	10%
Maximum Duty Cycle	100%	50%	25%	10%
Maximum ON Time (sec) when pulsed continuously <sup>1</sup>	∞	360	32	8
Maximum ON Time (sec) for single pulse <sup>2</sup>	∞	470	120	32
Watts (@ 20°C)	10	20	40	100
Ampere Turns (@ 20°C)	1166	1649	2332	3688

### Coil Data

awg (0XX) <sup>3</sup>	Resistance (@20°C)	# Turns <sup>4</sup>	VDC (Nom)	VDC (Nom)	VDC (Nom)	VDC (Nom)
23	1.96	536	4.4	6.3	8.9	14.0
24	2.69	600	5.2	7.3	10.4	16.4
25	4.89	840	7.0	9.9	14.0	22.0
26	8.44	1128	9.2	13.0	18.4	29.0
27	11.50	1260	10.7	15.2	21.0	34.0
28	19.20	1645	13.8	19.6	28.0	44.0
29	31.20	2104	17.7	25.0	35.0	56.0
30	49.60	2646	22.0	31.0	45.0	70.0
31	77.40	3280	28.0	39.0	56.0	88.0
32	119.00	4026	35.0	49.0	69.0	109.0
33	202.00	5317	45.0	64.0	90.0	142.0

- <sup>1</sup> Continuously pulsed at stated watts and duty cycle
- <sup>2</sup> Single pulse at stated watts (with coil at ambient room temperature 20°C)
- <sup>3</sup> Other coil awg sizes available — please consult factory
- <sup>4</sup> Reference number of turns

## Specifications

Dielectric Strength	1000 VRMS
Recommended Minimum Heat Sink	Maximum watts dissipated by solenoid are based on an unrestricted flow of air at 20°C, with solenoid mounted on the equivalent of an aluminium plate measuring 102 mm square by 3.2 mm thick
Coil Resistance	±5% tolerance
Holding Force	Flat Face: 52.6 N @ 20°C 60°: 28.9 N @ 20°C
Weight	190.8 g
Plunger Weight	33.7 g
Dimensions	See page F30

## How to Order

Add the plunger configuration number and the coil awg number to the part number (for example: to order a unit with a 60° plunger rated for 21 VDC at 25% duty cycle, specify 195227-227).

Please see [www.ledex.com](http://www.ledex.com) (click on Stock Products tab) for our list of stock products available through our distributors.

All specifications subject to change without notice.

# STA® Push Tubular Solenoids — 26 mm Dia. x 52 mm

## Push Tubular Solenoid – 26 mm dia. x 52 mm – Flat Face Plunger

Typical Force @ 20°C

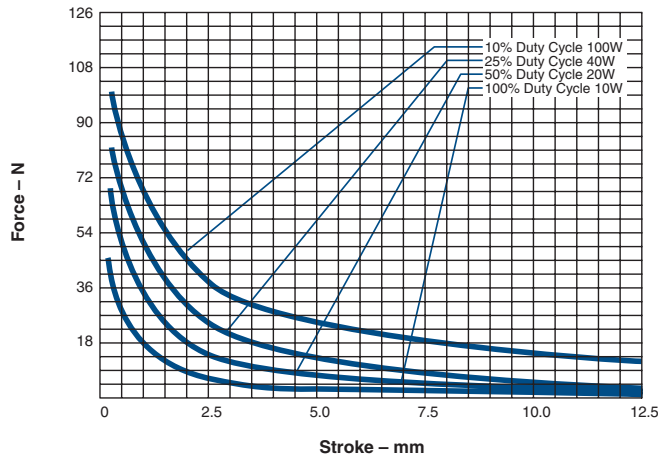

Typical Speed @ No Load, 20°C

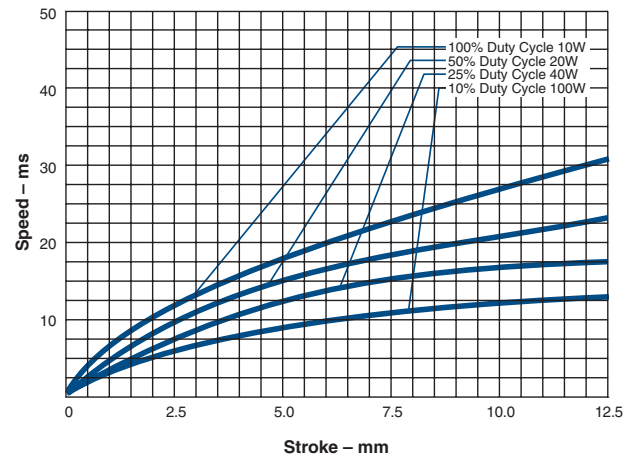

## Push Tubular Solenoid – 26 mm dia. x 52 mm – 60° Plunger

Typical Force @ 20°C

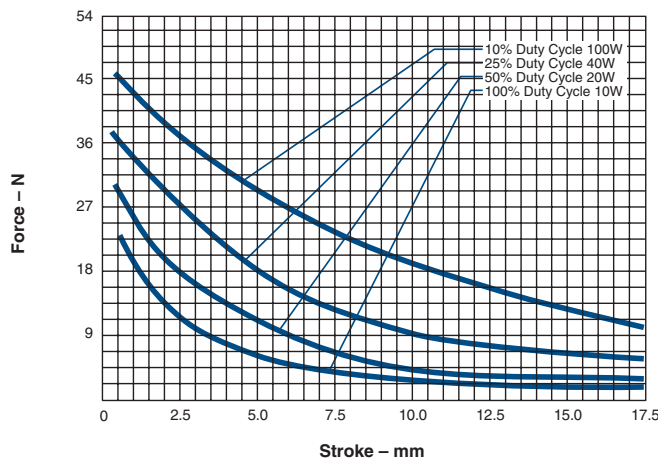

Typical Speed @ No Load, 20°C

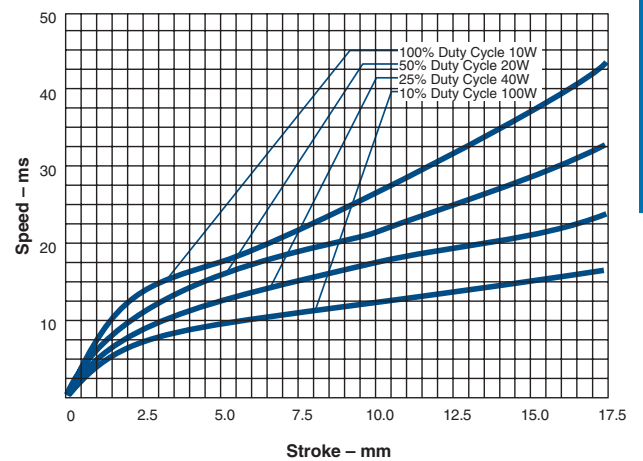

LINEAR Tubular

All specifications subject to change without notice.

# Ledex® Size 125M Pull Tubular Solenoids — 32 mm Dia. x 57 mm

Part Number: 282366-0XX

All catalogue products manufactured after April 1, 2006 are RoHS Compliant

## Performance

Maximum Duty Cycle	100%	50%	25%	10%
Maximum ON Time (sec) when pulsed continuously <sup>1</sup>	∞	390	60	18
Maximum ON Time (sec) for single pulse <sup>2</sup>	∞	510	160	45
Watts (@ 20°C)	13	26	52	130
Ampere Turns (@ 20°C)	1500	2121	3000	4743

### Coil Data

awg (0XX) <sup>3</sup>	Resistance (@20°C)	# Turns <sup>4</sup>	VDC (Nom)	VDC (Nom)	VDC (Nom)	VDC (Nom)
23	3.52	780	6.8	9.6	13.6	22.0
24	6.04	1056	8.6	12.2	17.2	27.0
25	8.47	1176	10.9	15.4	22.0	34.0
26	14.10	1540	13.8	19.5	28.0	44.0
27	22.50	1970	17.3	24.0	35.0	55.0
28	36.10	2484	22.0	31.0	44.0	69.0
29	55.10	3060	27.0	38.0	54.0	86.0
30	88.10	3805	35.0	49.0	70.0	110.0
31	147.00	5044	44.0	62.0	88.0	139.0
32	214.00	5992	54.0	76.0	107.0	170.0
33	354.00	7744	69.0	98.0	138.0	218.0

- <sup>1</sup> Continuously pulsed at stated watts and duty cycle
- <sup>2</sup> Single pulse at stated watts (with coil at ambient room temperature 20°C)
- <sup>3</sup> Other coil awg sizes available — please consult factory
- <sup>4</sup> Reference number of turns

## Specifications

Dielectric Strength	1000 VRMS
Recommended Minimum Heat Sink	Maximum watts dissipated by solenoid are based on an unrestricted flow of air at 20°C, with solenoid mounted on the equivalent of an aluminium plate measuring 127 mm square by 3.2 mm thick
Coil Resistance	±5% tolerance
Holding Force	40.0 N @ 20°C
Weight	295 g
Dimensions	See page F31

## How to Order

Add the coil awg number (0XX) to the part number (for example: to order a 25% duty cycle unit rated at 35 VDC, specify 282366-027).

Please see [www.ledex.com](http://www.ledex.com) (click on Stock Products tab) for our list of stock products available through our distributors.

LINEAR Tubular

## Size 125M Pull — Typical Force @ 20°C

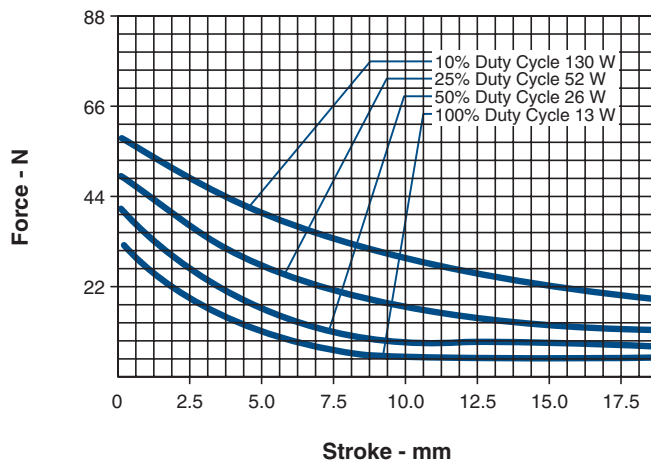

## Size 125M Pull — Typical Speed @ No Load, 20°C

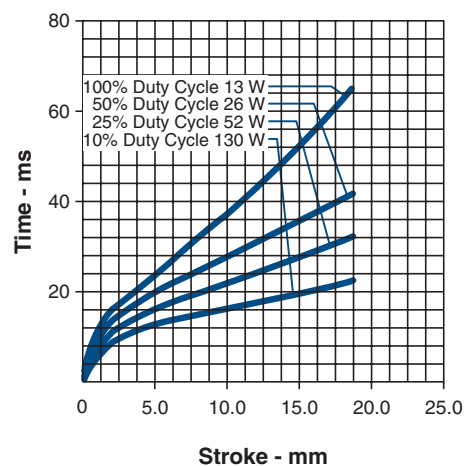

All specifications subject to change without notice.

# Ledex® Size 150M Pull Tubular Solenoids — 38 mm Dia. x 64 mm

Part Number: 282367-0XX

All catalogue products manufactured after April 1, 2006 are RoHS Compliant

## Performance

Maximum Duty Cycle	100%	50%	25%	10%
Maximum ON Time (sec) when pulsed continuously <sup>1</sup>	∞	420	100	25
Maximum ON Time (sec) for single pulse <sup>2</sup>	∞	570	252	75
Watts (@ 20°C)	17	34	68	170
Ampere Turns (@ 20°C)	1800	2546	3600	5692

Coil Data						
awg (0XX) <sup>3</sup>	Resistance (@20°C)	# Turns <sup>4</sup>	VDC (Nom)	VDC (Nom)	VDC (Nom)	VDC (Nom)
23	5.58	1030	9.8	13.9	19.7	31.0
24	9.30	1344	12.4	17.6	25.0	39.0
25	14.90	1712	15.7	22.0	31.0	50.0
26	24.00	2180	19.9	28.0	40.0	63.0
27	36.90	2680	25.0	35.0	50.0	79.0
28	58.40	3322	32.0	45.0	63.0	100.0
29	87.50	4008	39.0	56.0	79.0	124.0
30	148.00	5292	50.0	71.0	101.0	159.0
31	224.00	6360	63.0	90.0	127.0	200.0
32	344.00	7956	78.0	110.0	155.0	246.0
33	554.00	10070	100.0	141.0	199.0	315.0

- <sup>1</sup> Continuously pulsed at stated watts and duty cycle
- <sup>2</sup> Single pulse at stated watts (with coil at ambient room temperature 20°C)
- <sup>3</sup> Other coil awg sizes available — please consult factory
- <sup>4</sup> Reference number of turns

## Specifications

Dielectric Strength	1000 VRMS
Recommended Minimum Heat Sink	Maximum watts dissipated by solenoid are based on an unrestricted flow of air at 20°C, with solenoid mounted on the equivalent of an aluminium plate measuring 152 mm square by 3.2 mm thick
Coil Resistance	±5% tolerance
Holding Force	64.5 N at 20°C
Weight	481.8 g
Dimensions	See page F31

## How to Order

Add the coil awg number (0XX) to the part number (for example: to order a 25% duty cycle unit rated at 50 VDC, specify 282367-027).

Please see [www.ledex.com](http://www.ledex.com) (click on Stock Products tab) for our list of stock products available through our distributors.

LINEAR Tubular

## Size 150M Pull — Typical Force @ 20°C

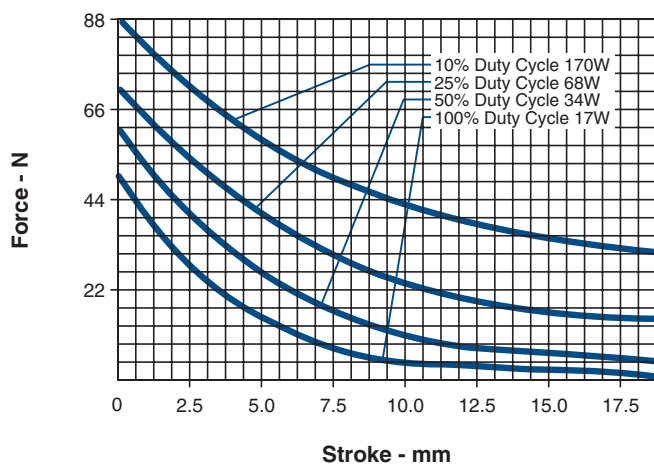

## Size 150M Pull — Typical Speed @ No Load, 20°C

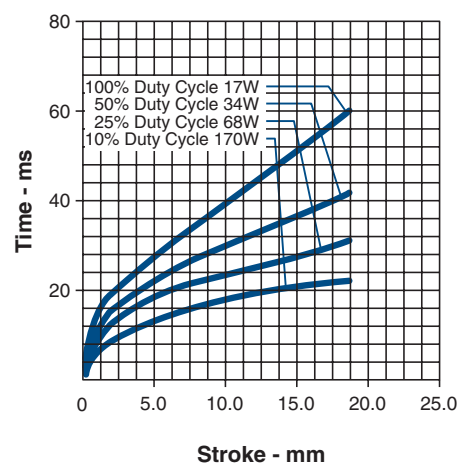

All specifications subject to change without notice.

# Ledex® Size 175M Pull Tubular Solenoids — 44 mm Dia. x 120 mm

Part Number: 196675-0XX

Class 180 H UL Recognised  
Coil Insulation System

UL File No. E131577

All catalogue products manufactured after  
April 1, 2006 are RoHS Compliant

## Performance

Maximum Duty Cycle	100%	50%	25%	10%
Maximum ON Time (sec) when pulsed continuously <sup>1</sup>	∞	882	209	54
Maximum ON Time (sec) for single pulse <sup>2</sup>	∞	1,200	528	162
Watts (@ 20°C)	20	40	80	200
Ampere Turns (@ 20°C)	2923	4133	5844	9238

Coil Data						
avg (0XX) <sup>3</sup>	Resistance (@20°C)	# Turns <sup>4</sup>	VDC (Nom)	VDC (Nom)	VDC (Nom)	VDC (Nom)
23	14.60	2544	17.1	24.2	34.2	54.0
24	23.30	3204	21.6	30.5	43.2	68.3
25	36.40	3990	27.0	38.2	54.0	85.3
26	56.20	4906	33.5	47.4	67.1	106.0
27	95.30	6474	43.7	61.7	87.3	138.1
28	142.90	7798	53.5	75.6	106.9	169.1
29	231.80	9952	68.1	96.3	136.2	215.3
30	368.40	12510	85.8	121.4	171.7	271.4
31	575.40	15520	107.3	151.7	214.6	339.2
32	940.20	19895	137.1	193.9	274.3	433.6
33	1,425.00	24125	168.8	238.7	337.6	533.9

- Continuously pulsed at stated watts and duty cycle
- Single pulse at stated watts (with coil at ambient room temperature 20°C)
- Other coil avg sizes available — please consult factory
- Reference number of turns

## Specifications

Dielectric Strength	1000 VRMS
Recommended Minimum Heat Sink	Maximum watts dissipated by solenoid are based on an unrestricted flow of air at 20°C, with solenoid mounted on the equivalent of an aluminium plate measuring 254 mm square by 3.2 mm thick
Coil Resistance	±5% tolerance
Holding Force	80.1 N @ 20°C
Weight	1.02 kg
Dimensions	See page F32

## How to Order

Add the coil avg number (0XX) to the part number (for example: to order a 25% duty cycle unit rated at 87 VDC, specify 196675-027).

Please see [www.ledex.com](http://www.ledex.com) (click on Stock Products tab) for our list of stock products available through our distributors.

LINEAR Tubular

## Size 175M Pull — Typical Force @ 20°C

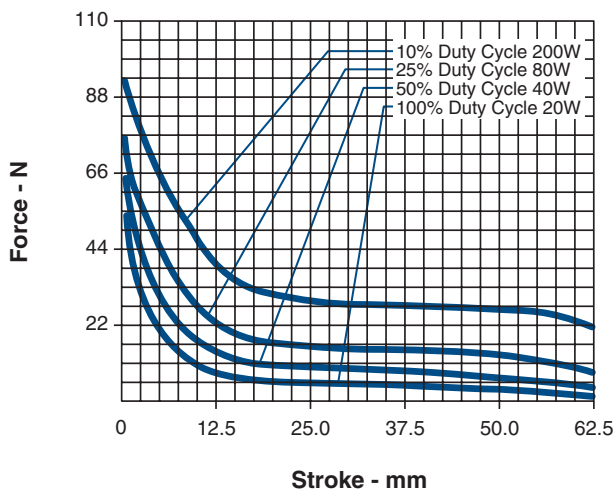

Force values for reference only.

## Size 175M Pull — Typical Speed @ No Load, 20°C

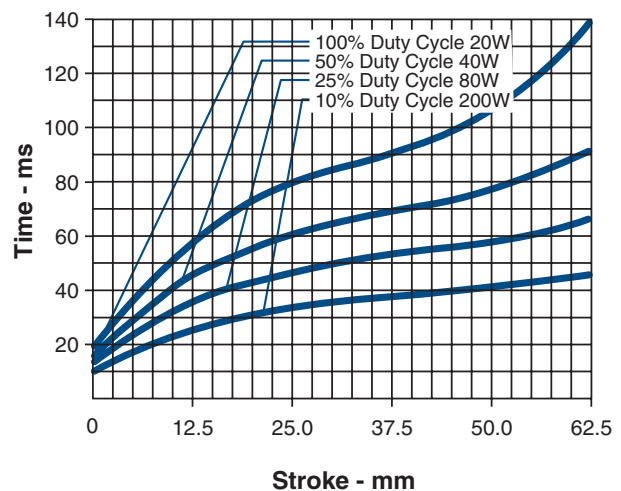

All specifications subject to change without notice.

# Ledex® Tubular Solenoids Dimensions

mm

## STA® Series Pull — 13 mm Dia. x 14 mm

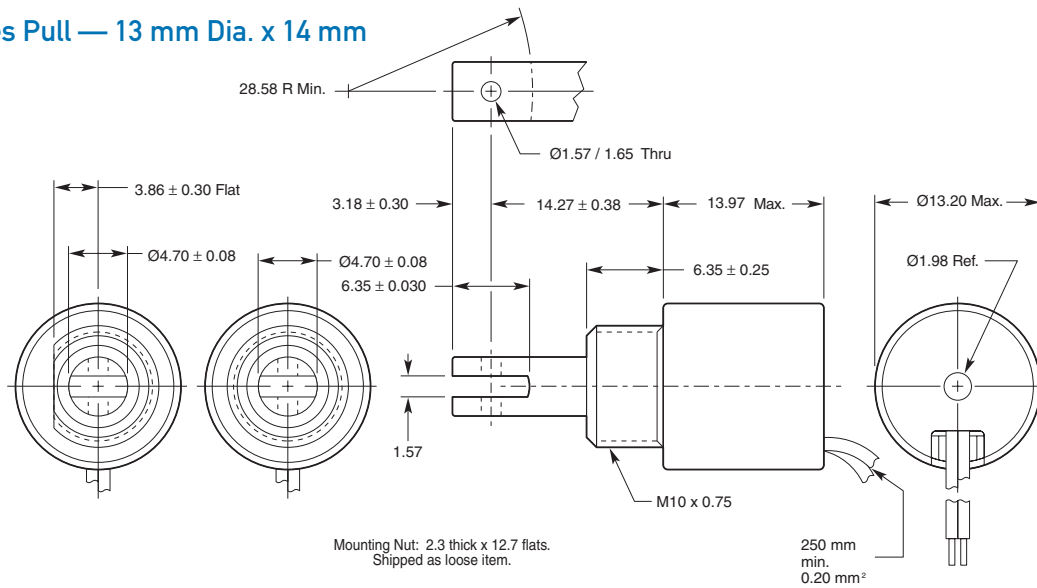

## STA® Series Magnetic Latching Pull — 13 mm Dia. x 16 mm

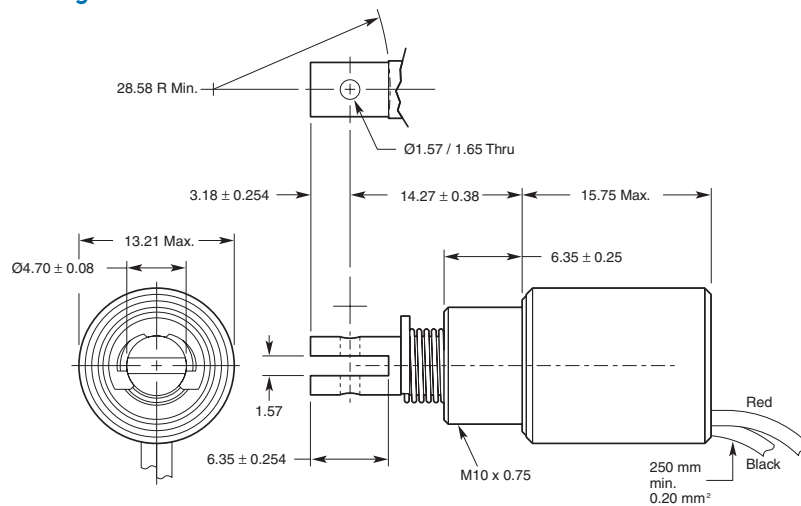

## STA® Series Push — 13 mm Dia. x 14 mm

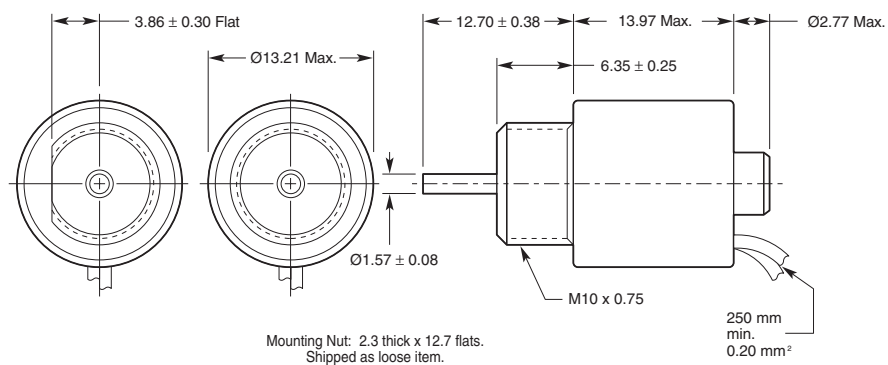

All solenoids are illustrated in energised state

All specifications subject to change without notice.

# Ledex® Tubular Solenoids Dimensions

mm

## STA® Series Pull — 13mm Dia. x 27 mm

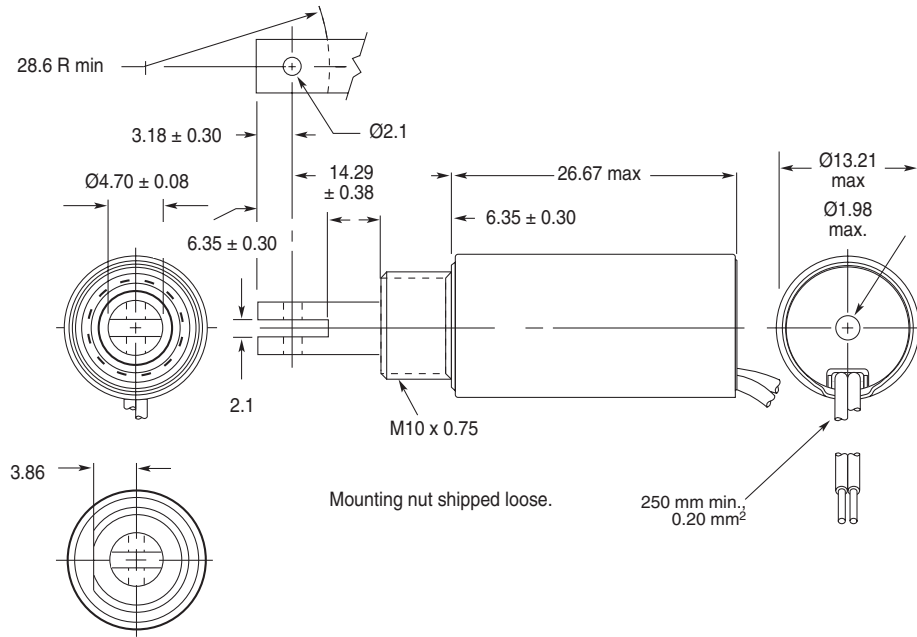

## STA® Series Push — 13 mm Dia. x 27 mm

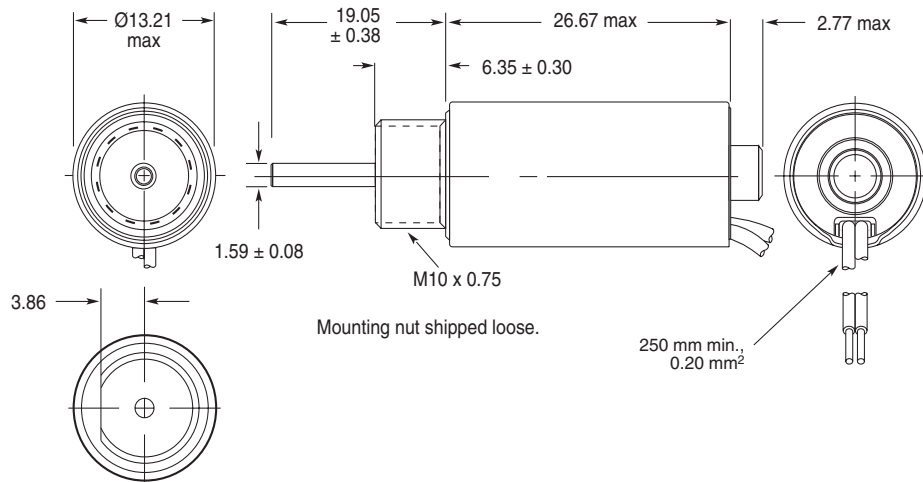

All solenoids are illustrated in energised state

All specifications subject to change without notice.

# Ledex<sup>®</sup> Tubular Solenoids Dimensions

mm

## STA<sup>®</sup> Series Pull — 20 mm Dia. x 40 mm

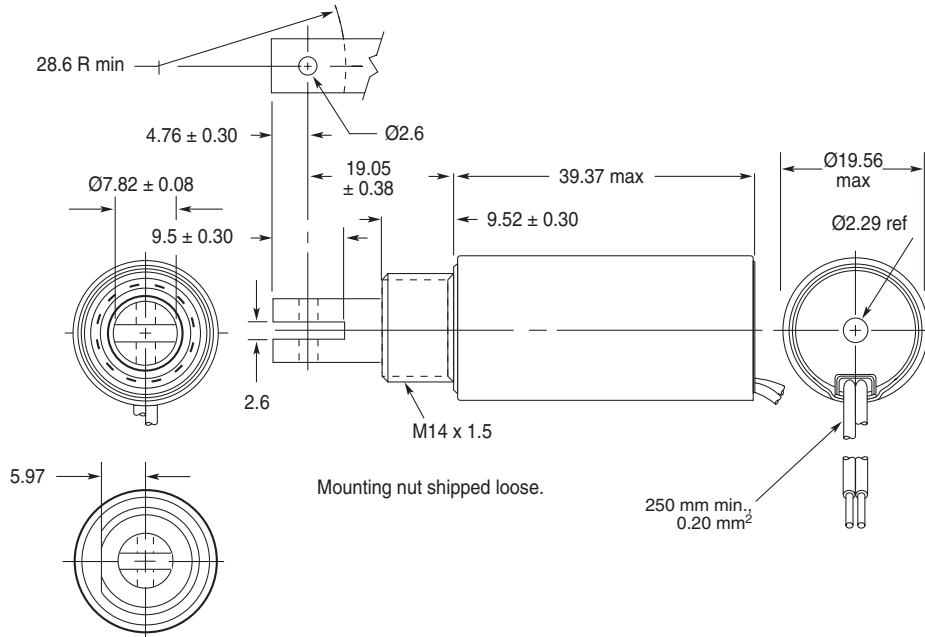

## STA<sup>®</sup> Series Push — 20 mm Dia. x 40 mm

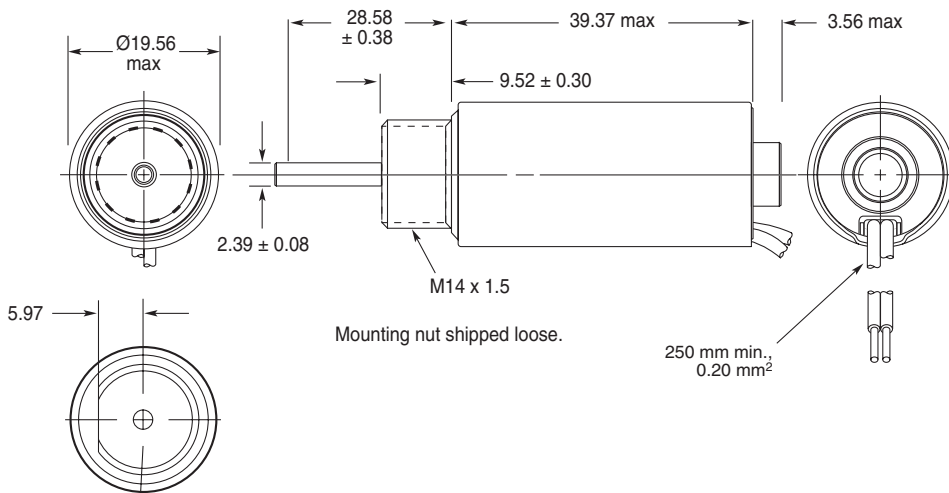

All solenoids are illustrated in energised state

All specifications subject to change without notice.

# Ledex® Tubular Solenoids Dimensions

mm

## STA® Series Pull — 26 mm Dia. x 52 mm

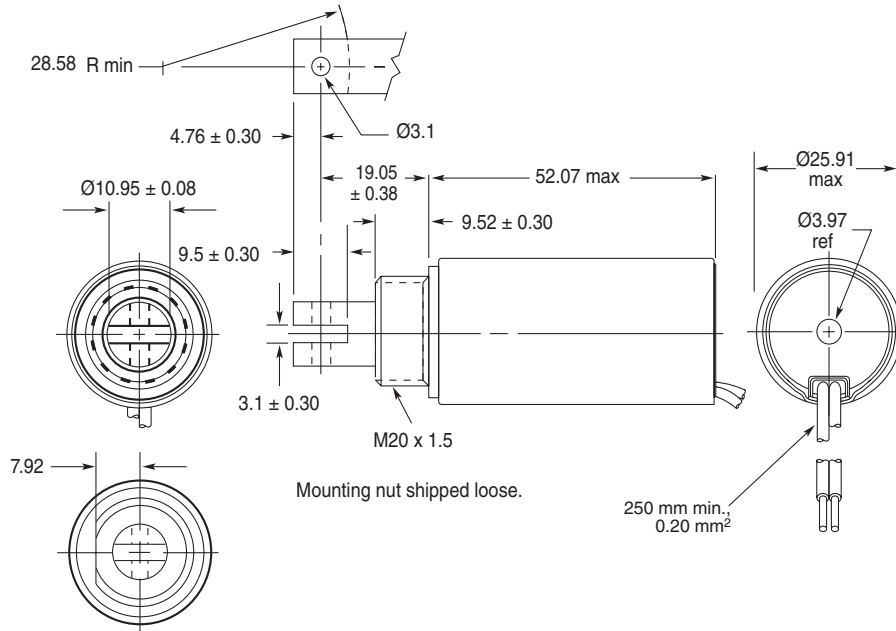

## STA® Series Push — 26 mm Dia. x 52 mm

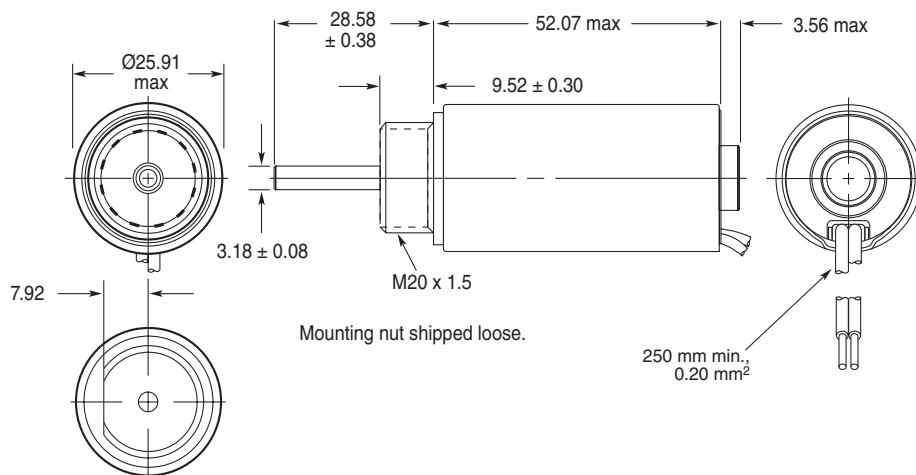

All solenoids are illustrated in energised state

All specifications subject to change without notice.

# Ledex® Tubular Solenoids Dimensions

mm

Ledex® Size 125M Pull — 32 mm Dia. x 57 mm

Ledex® Size 150M Pull — 38 mm Dia. x 64 mm

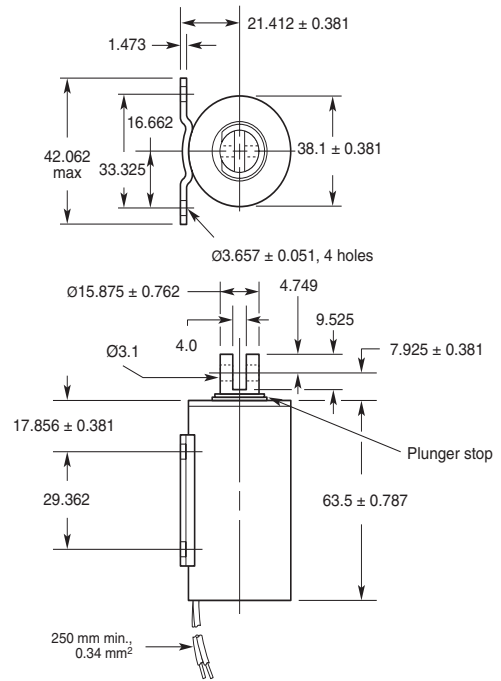
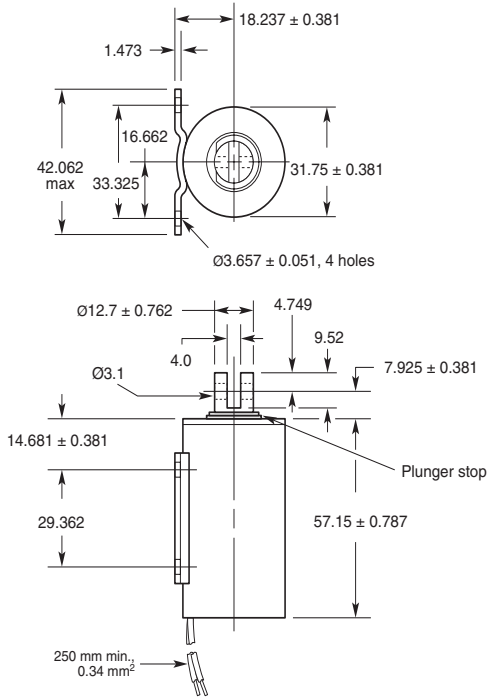

LINEAR Tubular

All solenoids are illustrated in energised state

All specifications subject to change without notice.



## Ledex<sup>®</sup> Low Profile Linear Solenoids

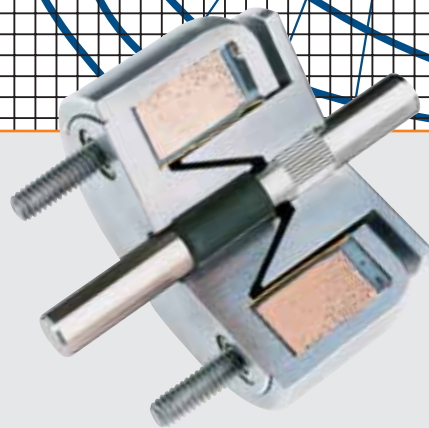
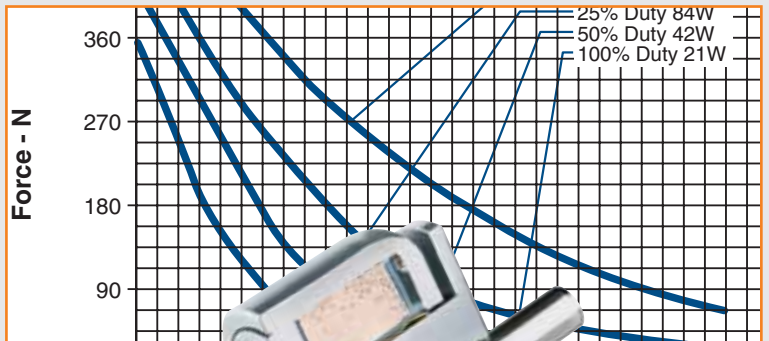

# Ledex® Low Profile Solenoids

LINEAR Low Profile



- Linear actuation
- Space-saving, low-profile configuration
- Ideal for high force, short stroke applications
- Forces to 845 N
- Stroke lengths to 18 mm



All catalogue products manufactured after April 1, 2006 are RoHS Compliant

The low profile shape, besides contributing to smaller size, optimises the magnetic flux paths for maximum force versus stroke characteristics. The construction of the plunger assembly provides an auxiliary flux path which permits a significant increase in force. The low profile solenoid construction not only provides long life, but also provides a rugged design for both military and commercial applications.

## Conical Face vs. Flat Face Plunger Design

Conical-faced designs extend the useful range of a solenoid to provide higher forces for strokes typically over 1.5 mm. The pole surface area is greater and the distance between the tapered cone faces is approximately one-half that of the gap between the land faces (for 30° angles), providing the effect of a closer air gap.

Flat Face: Higher efficiency for shorter strokes

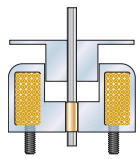

De-Energised

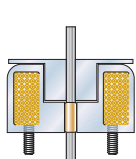

Energised

Conical Face: Higher force for longer strokes

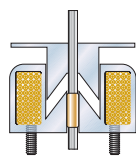

De-Energised

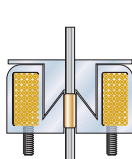

Energised

While some of the force component is lost because the force vector is not parallel with the plunger motion, the shorter gap and higher flux density combine to provide more output force for longer strokes.

For shorter strokes, the magnetic flux density increases and causes the iron to saturate rapidly as the poles move closer, thus reducing the efficiency of the conical-faced design. At this point, the flat-faced plunger is more efficient.

The main advantage of the flat-faced pole over the conical is that the full component of force is usable because the force vector is parallel with the pole motion.

## Applications

The reliability and high performance of Low Profile solenoids make them an ideal choice for applications in which consistent, reliable operation is critical.

- Pumps
- Machine tools
- Packaging machines
- Cranes
- Instruments
- Flow controls
- Trucks and buses
- Computer peripherals

# Ledex® Low Profile Solenoids

## Why Low Profile solenoids provide such high force and rapid response.

A key to the efficiency and compact form factor of the low profile solenoid is our special precision coil-winding process. With maximum copper packed into the allowable space, each solenoid develops tremendous force for its size and power input. The low profile form, in addition to contributing to smaller size, permits maximum pole face surface area for the magnetic flux.

Another factor that contributes to high efficiency is the additional iron surface on the external portion of the plunger; it provides an auxiliary flux path and a significant increase in force.

The force is also affected by other interrelated features, such as the length of the iron path, the magnetic saturation properties of the solenoid case and plunger, and the area and shape of the pole pieces.

The enclosed construction of the solenoid not only provides an iron path with minimum losses at the ring gap, but also provides a rugged design for critical environment applications

## Performance Curves

The performance curves in this section serve as guides to determine the solenoid size needed to produce a desired force at a given stroke, duty cycle, and power source. All curves were developed under the following standard test conditions: ambient temperature of 20°C, 65% relative humidity.

## Starting Force

When determining an application's force requirement, apply a 1.5 safety factor. For example: a load requiring 1.0 N of force should utilise a solenoid providing 1.0 N x 1.5 or 1.5 N of force.

## Duty Cycle

Duty cycle is determined by: ON time/(ON + OFF time).

For example: a solenoid is actuated for 30 seconds, then off for 90 seconds.  
 $30 \text{ sec ON} / (30 \text{ Sec ON} + 90 \text{ sec OFF}) = 30/120 = 1/4 \text{ or } 25\% \text{ duty cycle.}$

Ledex Low Profile solenoids are rated for various duty cycles ranging from continuous to 10% duty.

Note that maximum ON time for a particular application can be a factor which overrides the duty cycle rating. For example, at 25% duty cycle, the maximum ON time for a given Ledex solenoid is 36 seconds. If, however, the solenoid is operated at a cycle rate which enables the unit to return to ambient temperature between ON cycles, then the maximum ON time is extended somewhat. In the above example, this extended ON time is 44 seconds. Maximum ON time ratings are listed on the individual model specification pages.

## Typical Examples of Custom Features

Even though many solenoid designs are in stock, our customers often require a product with unique features or performance capabilities. So, if you don't find what you're looking for in the catalogue, give us a call to discuss your needs with one of our application engineers.

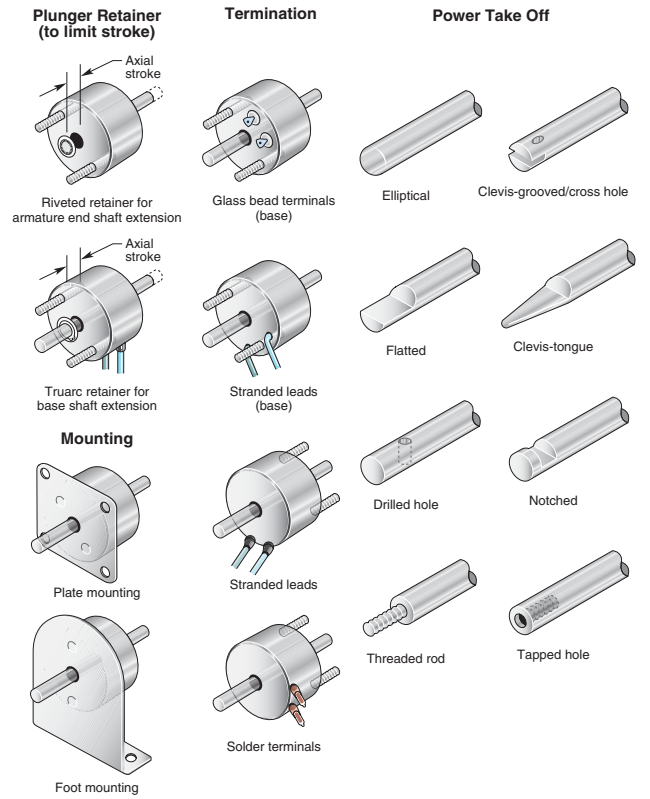

## Life

When selecting a Low Profile solenoid, as with any other solenoid style, it is important to consider factors that will affect the life of the unit. Heat, side-loading, stroke and operating environment all play an important role in determining the life you can expect in your application.

A simple, yet often overlooked method to improve Low Profile solenoid life is to minimise the side load. Maximum life can be achieved by mounting Low Profile solenoids so that the shaft travels along a vertical plane. Keeping the stroke as short as possible will also improve life.

## Power Requirements

Voltage applied to the solenoid must be matched to the coil wire size for proper operation. Solenoids are catalogued in coil awgs ranging from #25 up to #38 to accommodate your input power. Refer to the individual model specification pages for coil wire awg recommendations. Many other coil awg sizes are available. Please feel free to contact our application engineering department for availability.

# Ledex® Low Profile Selection

Low Profile solenoids are available in nine sizes. Use the selection chart to determine which size offers the desired performance and mechanical specifications. Refer to the individual size specification pages for complete performance and mechanical data.

All catalogue products manufactured after April 1, 2006 are RoHS Compliant

## Low Profile Selection Overview

Size*	Package Dimensions (mm)		Max Stroke (mm)	Nominal Stroke (mm)	Force (N) @ Nominal Stroke at Specified Duty Cycle @ 20°C			
	Dia.	Length			100%	50%	25%	10%
0ECM ●	19.0	12.7	3.81	1.5	0.9	2.0	4.2	9.2
1ECM ●	25.4	13.5	6.10	2.0	1.1	2.2	5.6	14.2
2EFM	28.6	14.7	1.78	0.8	8.9	15.6	31.2	60.0
2ECM ●	28.6	14.7	6.10	2.5	1.1	4.5	8.9	16.7
3EFM	33.3	17.5	1.78	1.0	11.1	22.3	49.0	89.0
3ECM	33.3	17.5	7.62	3.1	3.6	8.9	16.9	24.9
4EFM	39.7	21.2	3.04	1.5	13.4	28.9	53.4	111.3
4ECM	39.7	21.2	6.35	3.8	4.5	10.0	24.5	51.2
5SFM	47.6	22.4	3.56	2.0	13.4	42.3	75.7	173.6
5ECM	47.6	26.3	10.16	5.1	11.1	22.3	44.5	93.5
6SFM	57.2	29.1	4.57	2.0	44.5	89.0	178.0	356.0
6ECM	57.2	33.8	10.16	5.1	26.7	57.9	106.8	191.4
7ECM	69.9	45.2	17.78	7.6	40.1	80.1	146.9	240.3
8ECM	85.7	55.0	17.78	7.6	120.2	231.4	400.5	645.2

● Well-suited for battery operation.



See the "Battery Operated Solenoids" section for complete information.

All data is at 20°C coil temperature. Force outputs degrade with elevated temperatures.

\* EC sizes have conical face plungers, EF and SF sizes have flat face plungers.

## How to Use Low Profile Performance Charts

- Select one of the four columns which provides the appropriate duty cycle. (For example 50%.)
- Reading down this column provides a variety of performance and electrical data including maximum on time, watts, and amp turns.
- Following down the column further into the VDC ratings, select the voltage which most closely matches your supply voltage. (For example, 8.9 for a 9 VDC power supply.)
- Read across (to the left) to select the awg suffix to complete the part number when ordering. (In this example using our 0EC chart, 32 awg is required, thus to order, specify: 282340-032.)

## Performance

	100%	50%	25%	10%
Maximum Duty Cycle	∞	100	36	7
Maximum ON Time (sec) when pulsed continuously	∞	162	44	8
Maximum ON Time (sec) for single pulse	4.5	9	18	45
Watts (@ 20°C)	28.5	403	570	901

## Coil Data

avg (0XX)	Resistance (@20°C)	# Turns	VDC (Nom)	VDC (Nom)	VDC (Nom)	VDC (Nom)
26	0.50	90	1.6	2.3	3.2	5.1
27	0.97	136	2.0	2.8	3.9	6.3
28	1.33	152	2.6	3.7	5.1	8.1
29	2.40	215	3.2	4.4	6.2	9.9
30	3.29	240	4.1	5.7	8.0	12.7
31	5.61	324	5.0	7.1	9.9	15.8
32	9.09	420	6.3	8.9	12.4	19.7
33	14.95	544	8.0	11.3	15.7	25.0
34	24.06	684	10.2	14.4	20.0	32.0
35	37.10	840	12.8	18.1	25.0	40.0
36	58.51	1056	16.1	23.0	32.0	50.0
37	78.70	1109	19.8	28.0	39.0	62.0
38	123.00	1370	25.0	35.0	49.0	78.0

Force values for reference only.

All specifications subject to change without notice.

# Ledex® Low Profile Size 0ECM — Push or Pull

Medium Stroke, Conical Face

Part Number: 282340-0XX

All catalogue products manufactured after April 1, 2006 are RoHS Compliant

## Performance

Maximum Duty Cycle	100%	50%	25%	10%
Maximum ON Time (sec) when pulsed continuously <sup>1</sup>	∞	100	36	7
Maximum ON Time (sec) for single pulse <sup>2</sup>	∞	162	44	8
Watts (@ 20°C)	4.5	9	18	45
Ampere Turns (@ 20°C)	285	403	570	901

### Coil Data

awg (0XX) <sup>3</sup>	Resistance (@20°C)	# Turns <sup>4</sup>	VDC (Nom)	VDC (Nom)	VDC (Nom)	VDC (Nom)
26	0.50	90	1.6	2.3	3.2	5.1
27	0.97	136	2.0	2.8	3.9	6.3
28	1.33	152	2.6	3.7	5.1	8.1
29	2.40	215	3.2	4.4	6.2	9.9
30	3.29	240	4.1	5.7	8.0	12.7
31	5.61	324	5.0	7.1	9.9	15.8
32	9.09	420	6.3	8.9	12.4	19.7
33	14.95	544	8.0	11.3	15.7	25.0
34	24.06	684	10.2	14.4	20.0	32.0
35	37.10	840	12.8	18.1	25.0	40.0
36	58.51	1056	16.1	23.0	32.0	50.0
37	78.70	1109	19.8	28.0	39.0	62.0
38	123.00	1370	25.0	35.0	49.0	78.0

<sup>1</sup> Continuously pulsed at stated watts and duty cycle

<sup>2</sup> Single pulse at stated watts (with coil at ambient room temperature 20°C)

<sup>3</sup> Other coil awg sizes available — please consult factory

<sup>4</sup> Reference number of turns

## Specifications

Dielectric Strength	1000 VRMS
Recommended Minimum Heat Sink	Maximum watts dissipated by solenoid are based on an unrestricted flow of air at 20°C, with solenoid mounted on the equivalent of an aluminium plate measuring 51 mm square by 3.2 mm thick
Coil Resistance Weight	±10% tolerance on all coil awg sizes 24.8 g
Holding Force Dimensions	7.6 N @ 105°C See page G16

## How to Order

Add the coil awg number (0XX) to the part number (for example: to order a 25% duty cycle unit rated at 3.2 VDC, specify 282340-026).

Please see [www.ledex.com](http://www.ledex.com) (click on Stock Products tab) for our list of stock products available through our distributors.

- Well-suited for battery operation. See the "Battery Operated Solenoids" section for complete information.

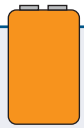

LINEAR Low Profile

## Size OECM — Typical Force @ 20°C

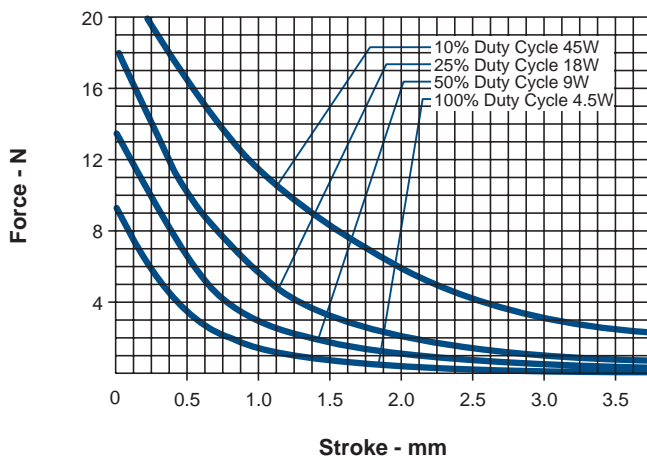

## Size OECM — Typical Speed @ No Load, 20°C

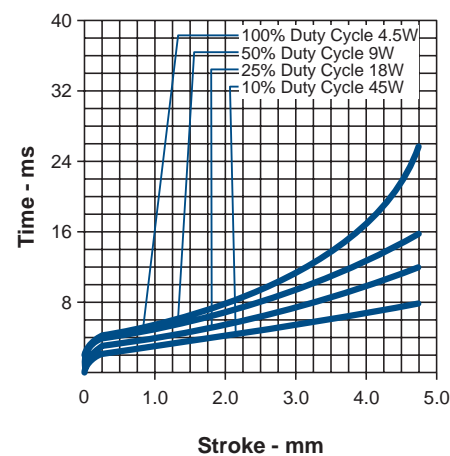

Force values for reference only.

All specifications subject to change without notice.

# Ledex® Low Profile Size 1ECM — Push or Pull

Medium Stroke, Conical Face

Part Number: 282342-0XX

All catalogue products manufactured after April 1, 2006 are RoHS Compliant

## Performance

Maximum Duty Cycle	100%	50%	25%	10%
Maximum ON Time (sec) when pulsed continuously <sup>1</sup>	∞	100	36	7
Maximum ON Time (sec) for single pulse <sup>2</sup>	∞	162	44	8
Watts (@ 20°C)	5	10	20	50
Ampere Turns (@ 20°C)	340	480	680	1075

Coil Data						
avg (0XX) <sup>3</sup>	Resistance (@20°C)	# Turns <sup>4</sup>	VDC (Nom)	VDC (Nom)	VDC (Nom)	VDC (Nom)
25	0.83	140	2.1	2.9	4.1	6.5
26	1.38	186	2.6	3.7	5.2	8.2
27	1.91	210	3.2	4.5	6.3	10.1
28	3.17	273	4.1	5.7	8.1	12.8
29	5.17	352	5.1	7.2	10.2	16.2
30	8.25	441	6.5	9.2	13.0	21.0
31	12.95	550	8.2	11.6	16.4	26.0
32	20.71	682	10.6	14.9	21.0	34.0
33	30.60	828	12.7	18.2	26.0	41.0
34	50.95	1078	16.5	23.0	33.0	52.0
35	83.92	1392	21.0	30.0	42.0	67.0
36	112.00	1500	26.0	37.0	52.0	83.0

- <sup>1</sup> Continuously pulsed at stated watts and duty cycle
- <sup>2</sup> Single pulse at stated watts (with coil at ambient room temperature 20°C)
- <sup>3</sup> Other coil avg sizes available — please consult factory
- <sup>4</sup> Reference number of turns

## Specifications

Dielectric Strength	1000 VRMS
Recommended Minimum Heat Sink	Maximum watts dissipated by solenoid are based on an unrestricted flow of air at 20°C, with solenoid mounted on the equivalent of an aluminium plate measuring 76 mm square by 3.2 mm thick
Coil Resistance	25-35 awg, ±5%; 36 awg, ±10%
Weight	42.5 g
Holding Force	24.0 N @ 105°C
Dimensions	See page G16

## How to Order

Add the coil awg number (0XX) to the part number (for example: to order a 25% duty cycle unit rated at 6.3 VDC, specify 282342-027).

Please see [www.ledex.com](http://www.ledex.com) (click on Stock Products tab) for our list of stock products available through our distributors.

LINEAR Low Profile

- Well-suited for battery operation. See the "Battery Operated Solenoids" section for complete information.



## Size 1ECM — Typical Force @ 20°C

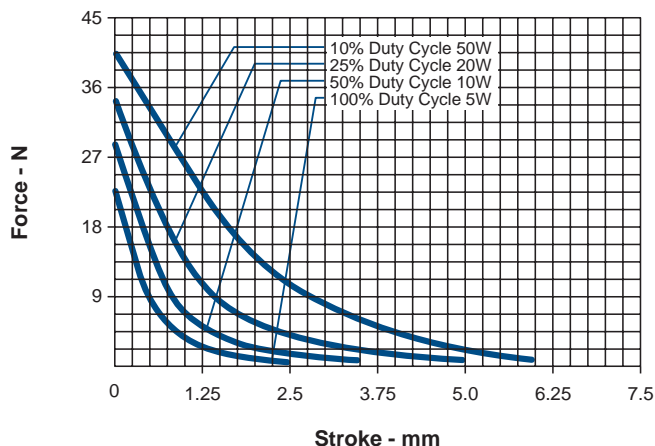

Force values for reference only.

## Size 1ECM— Typical Speed @ No Load, 20°C

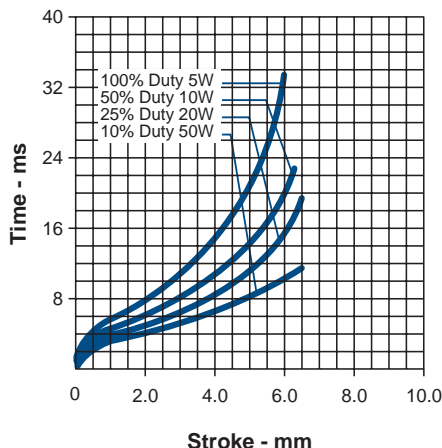

All specifications subject to change without notice.

# Ledex® Low Profile Size 2EFM/2ECM — Push or Pull

## Size 2EFM Short Stroke, Flat Face

Part Number: 282343-0XX

## Size 2ECM • Medium Stroke, Conical Face

Part Number: 282344-0XX

All catalogue products manufactured after April 1, 2006 are RoHS Compliant

### Performance

Maximum Duty Cycle	100%	50%	25%	10%
Maximum ON Time (sec) when pulsed continuously <sup>1</sup>	∞	100	36	7
Maximum ON Time (sec) for single pulse <sup>2</sup>	∞	162	44	8
Watts (@ 20°C)	7	14	28	70
Ampere Turns (@ 20°C)	425	602	849	1350

#### Coil Data

awg (0XX) <sup>3</sup>	Resistance (@20°C)	# Turns <sup>4</sup>	VDC (Nom)	VDC (Nom)	VDC (Nom)	VDC (Nom)
24	0.68	130	2.2	3.2	4.5	7.1
25	1.16	174	2.8	4.0	5.7	9.0
26	1.96	231	3.6	5.1	7.2	11.5
27	3.16	296	4.5	6.4	9.0	14.4
28	5.10	378	5.7	8.1	11.5	18.2
29	6.94	423	7.0	9.9	13.9	22.0
30	11.03	530	8.8	12.5	17.7	28.0
31	16.85	649	11.0	15.6	22.0	35.0
32	28.15	858	13.9	19.8	28.0	44.0
33	42.75	1036	17.5	25.0	35.0	56.0

- <sup>1</sup> Continuously pulsed at stated watts and duty cycle
- <sup>2</sup> Single pulse at stated watts (with coil at ambient room temperature 20°C)
- <sup>3</sup> Other coil awg sizes available — please consult factory
- <sup>4</sup> Reference number of turns

● Well-suited for battery operation. See the "Battery Operated Solenoids" section for complete information.



### Specifications

Dielectric Strength	1000 VRMS
Recommended Minimum Heat Sink	Maximum watts dissipated by solenoid are based on an unrestricted flow of air at 20°C, with solenoid mounted on the equivalent of an aluminium plate measuring 86 mm square by 3.2 mm thick
Coil Resistance	24-33 awg, ±5%
Weight	63.8 g
Holding Force 2EF	53.4 N @ 105°C
Holding Force 2EC	25.4 N @ 105°C
Dimensions	See page G16

### How to Order

Add the coil awg number (0XX) to the part number (for example: to order a 25% duty cycle unit rated at 9.0 VDC, specify 282343-027).

Please see [www.ledex.com](http://www.ledex.com) (click on Stock Products tab) for our list of stock products available through our distributors.

### Size 2EFM and 2ECM – Typical Speed @ No Load, 20°C

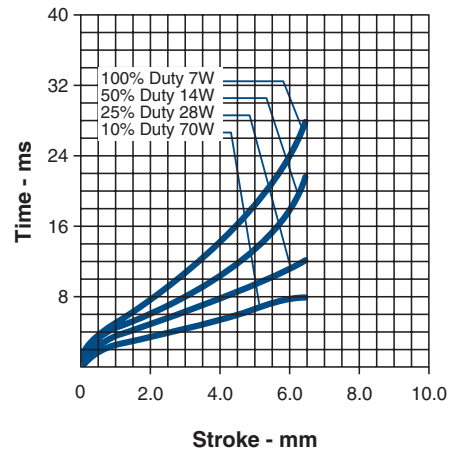

### Size 2EFM — Typical Force @ 20°C

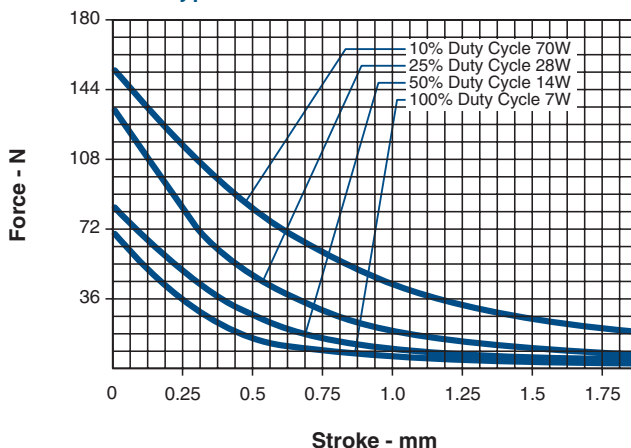

Force values for reference only.

### Size 2ECM — Typical Force @ 20°C

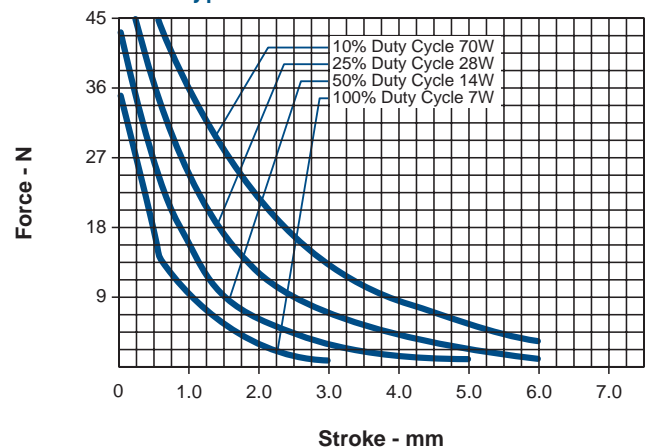

All specifications subject to change without notice.

# Ledex® Low Profile Size 3EFM/3ECM — Push or Pull

## Size 3EFM Short Stroke, Flat Face

Part Number: 282345-0XX

## Size 3ECM Medium Stroke, Conical Face

Part Number: 282346-0XX

### Performance

Maximum Duty Cycle	100%	50%	25%	10%
Maximum ON Time (sec) when pulsed continuously <sup>1</sup>	∞	100	36	8
Maximum ON Time (sec) for single pulse <sup>2</sup>	∞	162	44	9
Watts (@ 20°C)	9	18	36	90
Ampere Turns (@ 20°C)	535	756	1070	1690

#### Coil Data

awg (0XX) <sup>3</sup>	Resistance (@20°C)	# Turns <sup>4</sup>	VDC (Nom)	VDC (Nom)	VDC (Nom)	VDC (Nom)
23	0.70	145	2.6	3.7	5.2	8.2
24	1.18	192	3.3	4.6	6.6	10.4
25	1.97	252	4.2	5.9	8.4	13.2
26	3.26	328	5.3	7.5	10.6	16.8
27	5.04	405	6.7	9.4	13.3	21.0
28	8.02	510	8.4	11.9	16.8	27.0
29	12.21	627	10.4	14.7	21.0	33.0
30	19.20	780	13.2	18.6	26.0	42.0
31	31.84	1008	16.9	24.0	34.0	53.0
32	46.97	1215	21.0	29.0	41.0	65.0
33	75.30	1530	26.0	37.0	53.0	83.0

- Continuously pulsed at stated watts and duty cycle
- Single pulse at stated watts (with coil at ambient room temperature 20°C)
- Other coil awg sizes available — please consult factory
- Reference number of turns

### Size 3EFM— Typical Force @ 20°C

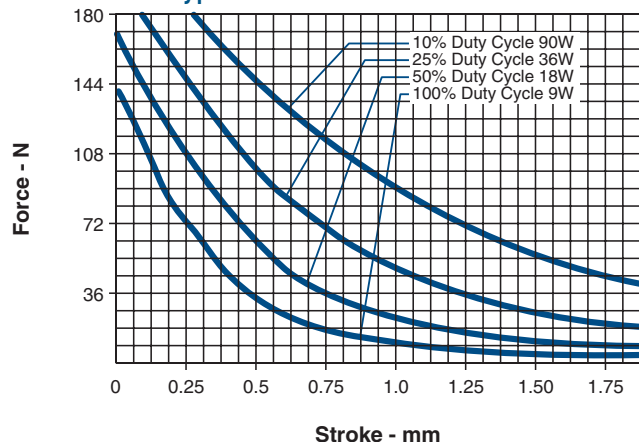

Force values for reference only.

### Specifications

Dielectric Strength	23-27 awg, 1000 VRMS ; 28-33 awg, 1200 VRMS
Recommended Minimum Heat Sink	Maximum watts dissipated by solenoid are based on an unrestricted flow of air at 20°C, with solenoid mounted on the equivalent of an aluminium plate measuring 118 mm square by 3.2 mm thick
Coil Resistance	23-33 awg, ±5%
Weight	106.3 g
Holding Force 3EF	115.6 N @ 105°C
Holding Force 3EC	53.4 N @ 105°C
Dimensions	See page G16

### How to Order

Add the coil awg number (0XX) to the part number (for example: to order a 25% duty cycle unit rated at 13.3 VDC, specify 282345-027).

Please see [www.ledex.com](http://www.ledex.com) (click on Stock Products tab) for our list of stock products available through our distributors.

### Size 3EFM and 3ECM – Typical Speed @ No Load, 20°C

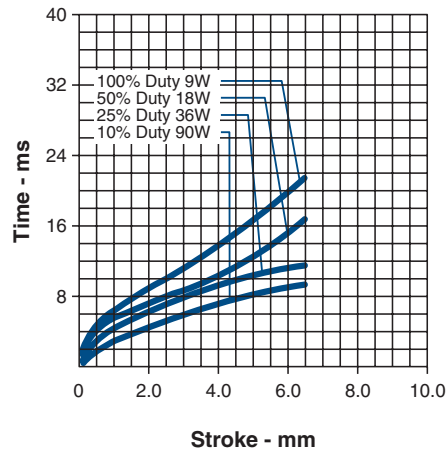

### Size 3ECM— Typical Force @ 20°C

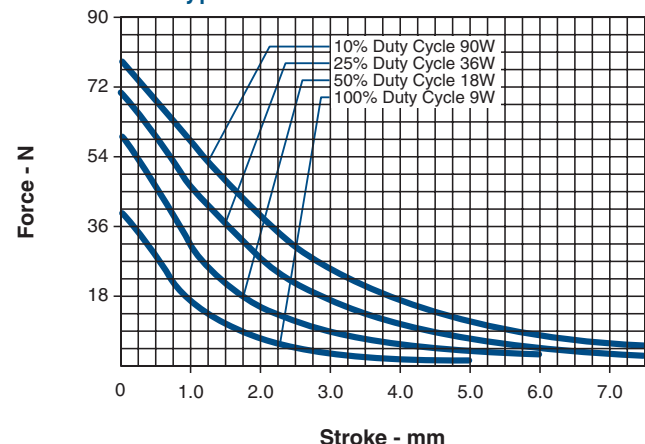

All specifications subject to change without notice.

# Ledex® Low Profile Size 4EFM/4ECM — Push or Pull

## Size 4EFM Short Stroke, Flat Face

Part Number: 282347-0XX

## Size 4ECM Medium Stroke, Conical Face

Part Number: 282348-0XX

All catalogue products manufactured after April 1, 2006 are RoHS Compliant

### Performance

Maximum Duty Cycle	100%	50%	25%	10%
Maximum ON Time (sec) when pulsed continuously <sup>1</sup>	∞	100	36	9
Maximum ON Time (sec) for single pulse <sup>2</sup>	∞	162	44	10
Watts (@ 20°C)	12.5	25	50	125
Ampere Turns (@ 20°C)	714	1000	1425	2250

### Coil Data

awg (0XX) <sup>3</sup>	Resistance (@20°C)	# Turns <sup>4</sup>	VDC (Nom)	VDC (Nom)	VDC (Nom)	VDC (Nom)
23	1.59	266	4.3	6.0	8.5	13.4
24	2.20	301	5.2	7.3	10.4	16.4
25	3.54	384	6.6	9.2	13.1	21.0
26	5.67	486	8.3	11.7	16.6	26.0
27	8.76	600	10.4	14.6	21.0	33.0
28	13.80	748	13.2	18.5	26.0	42.0
29	22.60	975	16.6	23.0	33.0	52.0
30	34.80	1190	21.0	29.0	42.0	66.0
31	56.70	1520	27.0	37.0	53.0	84.0
32	88.30	1908	33.0	46.0	66.0	104.0
33	138.00	2360	42.0	59.0	83.0	132.0

- Continuously pulsed at stated watts and duty cycle
- Single pulse at stated watts (with coil at ambient room temperature 20°C)
- Other coil awg sizes available — please consult factory
- Reference number of turns

### Specifications

Dielectric Strength	23-24 awg, 1000 VRMS ; 25-33 awg, 1200 VRMS
Recommended Minimum Heat Sink	Maximum watts dissipated by solenoid are based on an unrestricted flow of air at 20°C, with solenoid mounted on the equivalent of an aluminium plate measuring 159 mm square by 3.2 mm thick
Coil Resistance	23-33 awg, ±5%
Weight	170 g
Holding Force 4EF	164.6 N @ 105°C
Holding Force 4EC	71.2 N @ 105°C
Dimensions	See page G17

### How to Order

Add the coil awg number (0XX) to the part number (for example: to order a 25% duty cycle unit rated at 21 VDC, specify 282347-027).

Please see [www.ledex.com](http://www.ledex.com) (click on Stock Products tab) for our list of stock products available through our distributors.

### Size 4EFM and 4ECM—Typical Speed @ No Load, 20°C

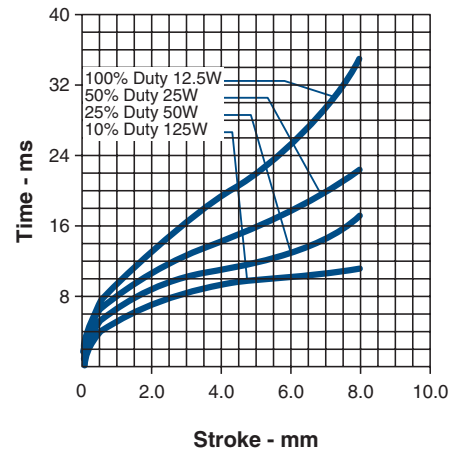

### Size 4EFM— Typical Force @ 20°C

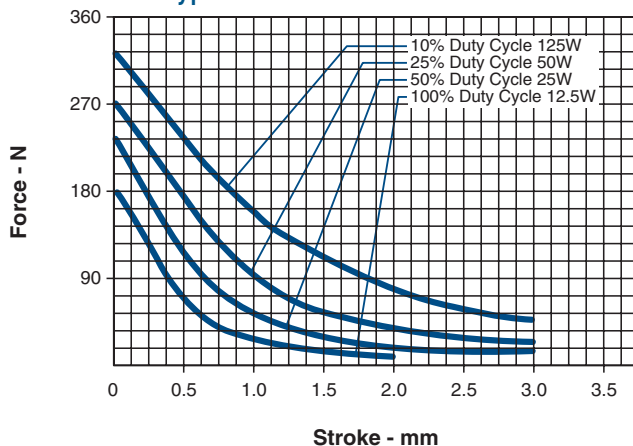

Force values for reference only.

### Size 4ECM— Typical Force @ 20°C

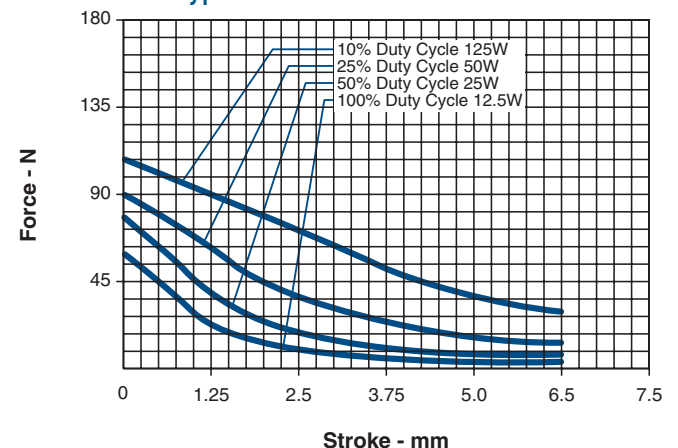

All specifications subject to change without notice.

# Ledex® Low Profile Size 5SFM — Push or Pull

Short Stroke, Flat Face  
Part Number: 282349-0XX

All catalogue products manufactured after  
April 1, 2006 are RoHS Compliant

## Performance

Maximum Duty Cycle	100%	50%	25%	10%
Maximum ON Time (sec) when pulsed continuously <sup>1</sup>	∞	100	36	10
Maximum ON Time (sec) for single pulse <sup>2</sup>	∞	160	44	13
Watts (@ 20°C)	21	42	84	210
Ampere Turns (@ 20°C)	860	1220	1720	2730

### Coil Data

awg (0XX) <sup>3</sup>	Resistance (@20°C)	# Turns <sup>4</sup>	VDC (Nom)	VDC (Nom)	VDC (Nom)	VDC (Nom)
23	2.03	288	6.1	8.6	12.1	19.2
24	3.20	360	7.6	10.8	15.3	24.0
25	4.91	440	9.6	13.6	19.2	31.0
26	7.72	550	12.1	17.1	24.0	38.0
27	11.12	636	15.0	21.0	30.0	48.0
28	18.79	840	19.2	27.0	39.0	61.0
29	30.48	1088	24.0	34.0	48.0	77.0
30	44.86	1275	30.0	43.0	61.0	96.0
31	70.90	1596	38.0	54.0	76.0	121.0
32	109.00	1974	47.0	67.0	95.0	150.0
33	175.00	2496	60.0	86.0	121.0	192.0

- <sup>1</sup> Continuously pulsed at stated watts and duty cycle
- <sup>2</sup> Single pulse at stated watts (with coil at ambient room temperature 20°C)
- <sup>3</sup> Other coil awg sizes available — please consult factory
- <sup>4</sup> Reference number of turns

## Specifications

Dielectric Strength	23 awg, 1000 VRMS ; 24-33 awg, 1200 VRMS
Recommended Minimum Heat Sink	Maximum watts dissipated by solenoid are based on an unrestricted flow of air at 20°C, with solenoid mounted on the equivalent of an aluminium plate measuring 191 mm square by 3.2 mm thick
Coil Resistance	23-33 awg, ±5%
Weight	255 g
Holding Force	258.0 N @ 105°C
Dimensions	See page G17

## How to Order

Add the coil awg number (0XX) to the part number (for example: to order a 25% duty cycle unit rated at 50 VDC, specify 282349-027).

Please see [www.ledex.com](http://www.ledex.com) (click on Stock Products tab) for our list of stock products available through our distributors.

LINEAR Low Profile

Size 5SFM— Typical Force @ 20°C

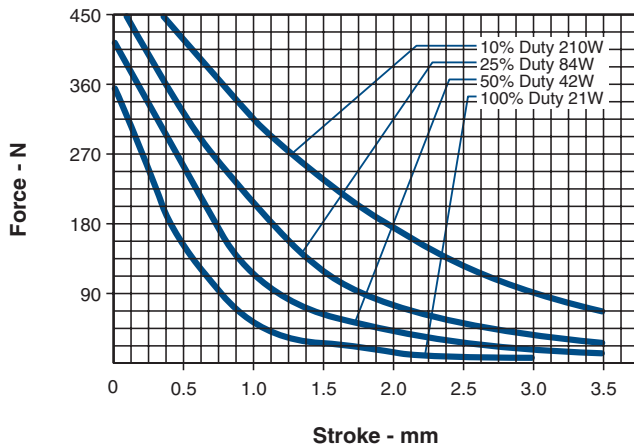

Size 5SFM— Typical Speed @ No Load, 20°C

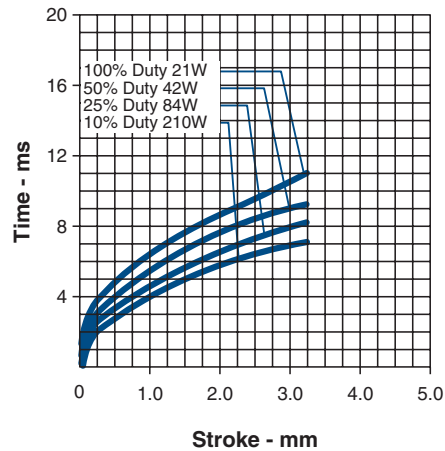

Force values for reference only.

All specifications subject to change without notice.

# Ledex® Low Profile Size 5ECM — Push or Pull

Medium Stroke, Conical Face  
Part Number: 282350-0XX

All catalogue products manufactured after April 1, 2006 are RoHS Compliant

## Performance

Maximum Duty Cycle	100%	50%	25%	10%
Maximum ON Time (sec) when pulsed continuously <sup>1</sup>	∞	100	36	10
Maximum ON Time (sec) for single pulse <sup>2</sup>	∞	160	44	13
Watts (@ 20°C)	21	42	84	210
Ampere Turns (@ 20°C)	1015	1440	2030	3210

### Coil Data

awg (0XX) <sup>3</sup>	Resistance (@20°C)	# Turns <sup>4</sup>	VDC (Nom)	VDC (Nom)	VDC (Nom)	VDC (Nom)
23	2.70	384	7.2	10.1	14.3	23.0
24	4.30	486	9.0	12.7	18.0	28.0
25	6.66	590	11.5	16.2	23.0	36.0
26	10.30	737	14.0	20.0	28.0	44.0
27	15.70	900	17.7	25.0	35.0	56.0
28	26.60	1190	23.0	32.0	45.0	72.0
29	38.00	1380	28.0	40.0	56.0	89.0
30	62.10	1768	36.0	51.0	71.0	113.0
31	96.10	2166	45.0	64.0	90.0	143.0
32	157.00	2816	57.0	80.0	113.0	179.0
33	241.00	3432	71.0	101.0	143.0	226.0

- <sup>1</sup> Continuously pulsed at stated watts and duty cycle
- <sup>2</sup> Single pulse at stated watts (with coil at ambient room temperature 20°C)
- <sup>3</sup> Other coil awg sizes available — please consult factory
- <sup>4</sup> Reference number of turns

## Specifications

Dielectric Strength	23 awg, 1000 VRMS ; 24-33 awg, 1200 VRMS
Recommended Minimum Heat Sink	Maximum watts dissipated by solenoid are based on an unrestricted flow of air at 20°C, with solenoid mounted on the equivalent of an aluminium plate measuring 191 mm square by 3.2 mm thick
Coil Resistance	23-33 awg, ±5%
Weight	326.0 g
Holding Force	120.1 N @ 105°C
Dimensions	See page G17

## How to Order

Add the coil awg number (0XX) to the part number (for example: to order a 25% duty cycle unit rated at 35 VDC, specify 282350-027).

Please see [www.ledex.com](http://www.ledex.com) (click on Stock Products tab) for our list of stock products available through our distributors.

LINEAR Low Profile

Size 5ECM— Typical Force @ 20°C

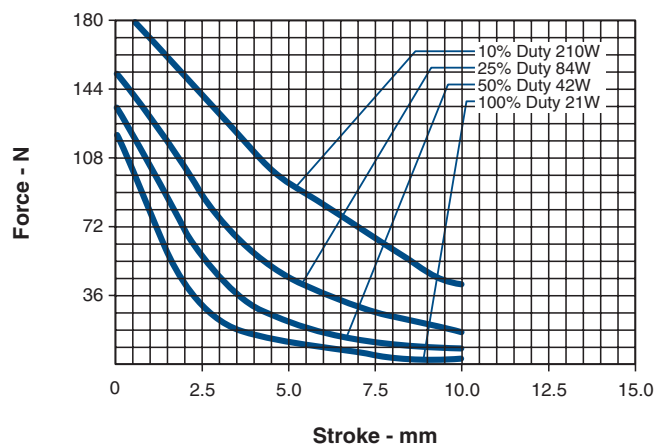

Size 5ECM— Typical Speed @ No Load, 20°C

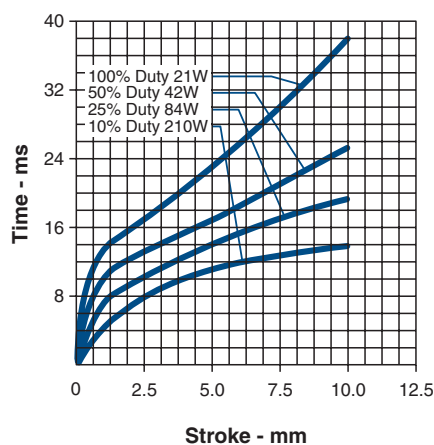

Force values for reference only.

All specifications subject to change without notice.

# Ledex® Low Profile Size 6SFM — Push or Pull

Short Stroke, Flat Face  
Part Number: 282351-0XX

All catalogue products manufactured after  
April 1, 2006 are RoHS Compliant

## Performance

Maximum Duty Cycle	100%	50%	25%	10%
Maximum ON Time (sec) when pulsed continuously <sup>1</sup>	∞	87	36	13
Maximum ON Time (sec) for single pulse <sup>2</sup>	∞	140	44	16
Watts (@ 20°C)	32	64	128	320
Ampere Turns (@ 20°C)	1240	1760	2490	3920

### Coil Data

avg (0XX) <sup>3</sup>	Resistance (@20°C)	# Turns <sup>4</sup>	VDC (Nom)	VDC (Nom)	VDC (Nom)	VDC (Nom)
23	3.59	432	10.3	14.6	21.0	33.0
24	5.24	500	13.0	18.4	26.0	41.0
25	9.51	708	16.7	24.0	33.0	53.0
26	14.44	858	21.0	30.0	42.0	66.0
27	23.69	1110	27.0	38.0	53.0	84.0
28	38.27	1411	34.0	48.0	68.0	106.0
29	54.62	1638	41.0	59.0	83.0	131.0
30	93.67	2184	53.0	76.0	107.0	168.0
31	143.00	2645	67.0	95.0	134.0	211.0
32	223.00	3328	83.0	118.0	167.0	262.0
33	338.00	4004	105.0	149.0	210.0	331.0

- <sup>1</sup> Continuously pulsed at stated watts and duty cycle
- <sup>2</sup> Single pulse at stated watts (with coil at ambient room temperature 20°C)
- <sup>3</sup> Other coil avg sizes available — please consult factory
- <sup>4</sup> Reference number of turns

## Specifications

Dielectric Strength	23-31 awg, 1200 VRMS ; 32-33 awg, 1500 VRMS
Recommended Minimum Heat Sink	Maximum watts dissipated by solenoid are based on an unrestricted flow of air at 20°C, with solenoid mounted on the equivalent of an aluminium plate measuring 314 mm square by 3.2 mm thick
Coil Resistance	23-33 awg, ±5%
Weight	510.3 g
Holding Force	391.4 N @ 105°C
Dimensions	See page G18

## How to Order

Add the coil awg number (0XX) to the part number (for example: to order a 25% duty cycle unit rated at 55 VDC, specify 282351-027).

Please see [www.ledex.com](http://www.ledex.com) (click on Stock Products tab) for our list of stock products available through our distributors.

LINEAR Low Profile

## Size 6SFM— Typical Force @ 20°C

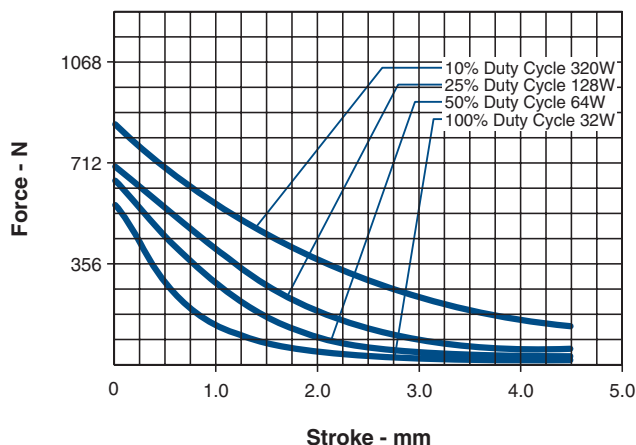

## Size 6SFM— Typical Speed @ No Load, 20°C

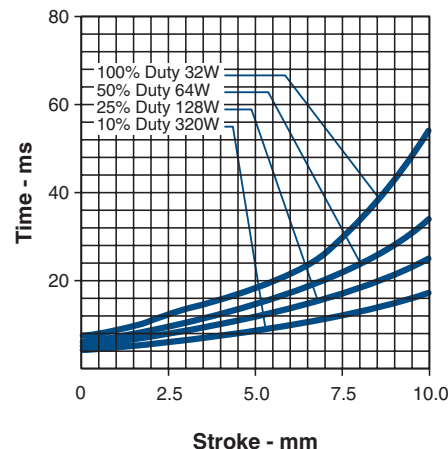

Force values for reference only.

All specifications subject to change without notice.

# Ledex® Low Profile Size 6ECM — Push or Pull

Medium Stroke, Conical Face  
Part Number: 282352-0XX

All catalogue products manufactured after April 1, 2006 are RoHS Compliant

## Performance

Maximum Duty Cycle	100%	50%	25%	10%
Maximum ON Time (sec) when pulsed continuously <sup>1</sup>	∞	87	36	13
Maximum ON Time (sec) for single pulse <sup>2</sup>	∞	140	44	16
Watts (@ 20°C)	32	64	128	320
Ampere Turns (@ 20°C)	1480	2080	2940	4620

Coil Data						
awg (0XX) <sup>3</sup>	Resistance (@20°C)	# Turns <sup>4</sup>	VDC (Nom)	VDC (Nom)	VDC (Nom)	VDC (Nom)
23	4.69	567	12.3	17.2	24.0	38.0
24	7.43	710	15.5	22.0	31.0	48.0
25	12.90	960	19.9	28.0	39.0	62.0
26	19.70	1170	25.0	35.0	49.0	78.0
27	32.00	1500	32.0	44.0	63.0	99.0
28	51.60	1904	40.0	56.0	79.0	125.0
29	74.40	2232	49.0	69.0	98.0	154.0
30	126.00	2940	63.0	89.0	126.0	198.0
31	195.00	3611	80.0	112.0	159.0	250.0
32	288.00	4350	98.0	138.0	195.0	306.0
33	427.00	5010	126.0	177.0	251.0	394.0

- Continuously pulsed at stated watts and duty cycle
- Single pulse at stated watts (with coil at ambient room temperature 20°C)
- Other coil awg sizes available — please consult factory
- Reference number of turns

## Specifications

Dielectric Strength	23-31 awg, 1200 VRMS ; 32-33 awg, 1500 VRMS
Recommended Minimum Heat Sink	Maximum watts dissipated by solenoid are based on an unrestricted flow of air at 20°C, with solenoid mounted on the equivalent of an aluminium plate measuring 314 mm square by 3.2 mm thick
Coil Resistance	23-33 awg, ±5%
Weight	609.5 g
Holding Force	218.0 N @ 105°C
Dimensions	See page G18

## How to Order

Add the coil awg number (0XX) to the part number (for example: to order a 25% duty cycle unit rated at 63 VDC, specify 282352-027).

Please see [www.ledex.com](http://www.ledex.com) (click on Stock Products tab) for our list of stock products available through our distributors.

LINEAR Low Profile

Size 6ECM— Typical Force at 20°C

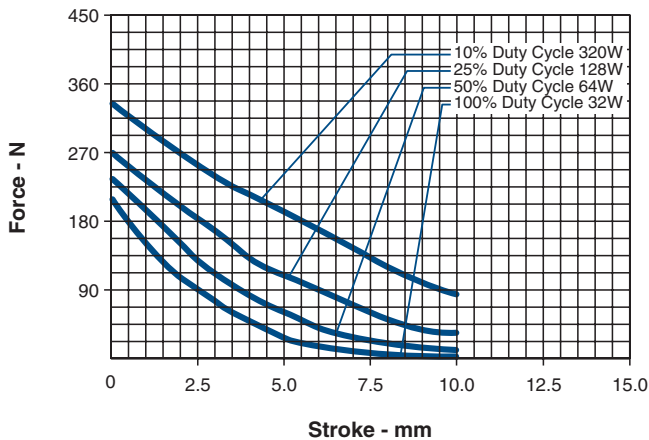

Force values for reference only.

Size 6ECM— Typical Speed @ No Load, 20°C

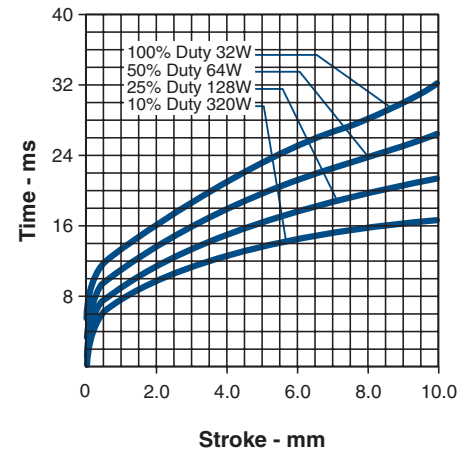

All specifications subject to change without notice.

# Ledex® Low Profile Size 7ECM — Push or Pull

Medium Stroke, Conical Face  
Part Number: 282354-0XX

All catalogue products manufactured after April 1, 2006 are RoHS Compliant

## Performance

Maximum Duty Cycle	100%	50%	25%	10%
Maximum ON Time (sec) when pulsed continuously <sup>1</sup>	∞	80	38	16
Maximum ON Time (sec) for single pulse <sup>2</sup>	∞	138	50	18
Watts (@ 20°C)	35	70	140	350
Ampere Turns (@ 20°C)	1805	2555	3610	5710

### Coil Data

awg (0XX) <sup>3</sup>	Resistance (@20°C)	# Turns <sup>4</sup>	VDC (Nom)	VDC (Nom)	VDC (Nom)	VDC (Nom)
23	10.80	1044	19.0	27.0	39.0	61.0
24	16.50	1274	24.0	34.0	48.0	76.0
25	27.00	1635	31.0	43.0	61.0	97.0
26	43.80	2091	39.0	55.0	78.0	124.0
27	68.40	2603	49.0	69.0	98.0	155.0
28	108.00	3255	61.0	87.0	123.0	194.0
29	162.00	3933	75.0	106.0	151.0	238.0
30	265.00	5044	96.0	136.0	193.0	305.0
31	385.00	5800	116.0	164.0	232.0	367.0
32	583.00	7230	143.0	202.0	286.0	452.0
33	882.00	8400	176.0	248.0	351.0	600.0

- <sup>1</sup> Continuously pulsed at stated watts and duty cycle
- <sup>2</sup> Single pulse at stated watts (with coil at ambient room temperature 20°C)
- <sup>3</sup> Other coil awg sizes available — please consult factory
- <sup>4</sup> Reference number of turns

## Specifications

Dielectric Strength	23-29 awg, 1200 VRMS ; 30-33 awg, 1500 VRMS
Recommended Minimum Heat Sink	Maximum watts dissipated by solenoid are based on an unrestricted flow of air at 20°C, with solenoid mounted on the equivalent of an aluminium plate measuring 384 m square by 3.2 mm thick
Coil Resistance	23-30 awg, ±5%; 31-33 awg, ±10%
Weight	1.134 kg
Holding Force	222.4 N @ 105°C
Dimensions	See page G18

## How to Order

Add the coil awg number (0XX) to the part number (for example: to order a 25% duty cycle unit rated at 48 VDC, specify 282354-024).

Please see [www.ledex.com](http://www.ledex.com) (click on Stock Products tab) for our list of stock products available through our distributors.

LINEAR Low Profile

Size 7ECM— Typical Force @ 20°C

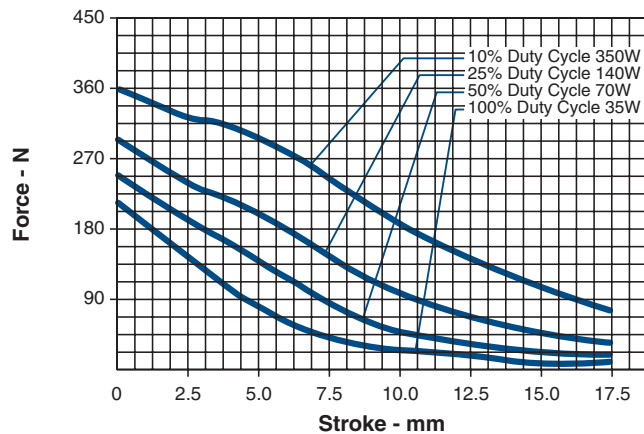

Size 7ECM— Typical Speed @ No Load, 20°C

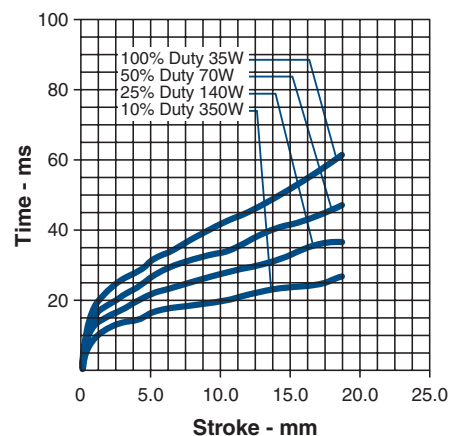

Force values for reference only.

All specifications subject to change without notice.

# Ledex® Low Profile Size 8ECM — Push or Pull

Medium Stroke, Conical Face  
Part Number: 282356-0XX

All catalogue products manufactured after April 1, 2006 are RoHS Compliant

## Performance

Maximum Duty Cycle	100%	50%	25%	10%
Maximum ON Time (sec) when pulsed continuously <sup>1</sup>	∞	72	43	20
Maximum ON Time (sec) for single pulse <sup>2</sup>	∞	132	56	22
Watts (@ 20°C)	41	82	164	410
Ampere Turns (@ 20°C)	2195	3105	4155	6945

### Coil Data

awg (0XX) <sup>3</sup>	Resistance (@20°C)	# Turns <sup>4</sup>	VDC (Nom)	VDC (Nom)	VDC (Nom)	VDC (Nom)
23	19.00	1512	28.0	40.0	56.0	88.0
24	31.20	1952	36.0	51.0	72.0	113.0
25	49.40	2448	45.0	64.0	90.0	142.0
26	78.00	3060	57.0	80.0	113.0	179.0
27	119.00	3740	70.0	99.0	140.0	221.0
28	184.00	4584	87.0	123.0	174.0	275.0
29	301.00	5936	111.0	157.0	222.0	351.0
30	425.00	6750	132.0	187.0	264.0	417.0
31	683.00	8750	167.0	237.0	335.0	529.0
32	1110.00	11000	213.0	302.0	427.0	—
33	1509.00	12050	249.0	352.0	498.0	—

- Continuously pulsed at stated watts and duty cycle
- Single pulse at stated watts (with coil at ambient room temperature 20°C)
- Other coil awg sizes available — please consult factory
- Reference number of turns

## Specifications

Dielectric Strength	23-27 awg, 1200 VRMS ; 28-33 awg, 1500 VRMS
Recommended Minimum Heat Sink	Maximum watts dissipated by solenoid are based on an unrestricted flow of air at 20°C, with solenoid mounted on the equivalent of an aluminium plate measuring 514 mm square by 3.2 mm thick
Coil Resistance	23-30 awg, ±5%; 31-33 awg, ±10%
Weight	2.2 kg
Holding Force	533.7 N @ 105°C
Dimensions	See page G18

## How to Order

Add the coil awg number (0XX) to the part number (for example: to order a 25% duty cycle unit rated at 90 VDC, specify 282356-025).

Please see [www.ledex.com](http://www.ledex.com) (click on Stock Products tab) for our list of stock products available through our distributors.

LINEAR Low Profile

Size 8ECM— Typical Force at 20°C

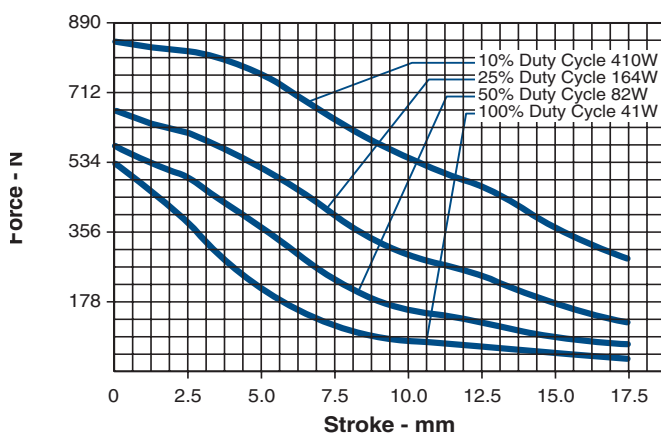

Size 8ECM— Typical Speed @ No Load, 20°C

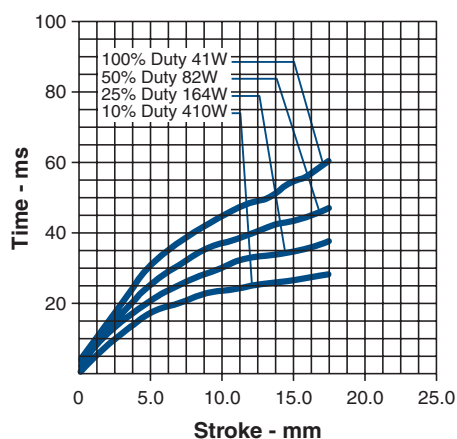

Force values for reference only.

All specifications subject to change without notice.

# Ledex® Low Profile Dimensions

mm

All solenoids are illustrated in energised state

Size OEC

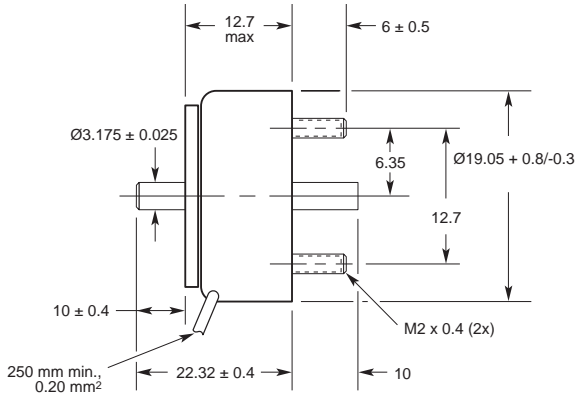

Size 1EC

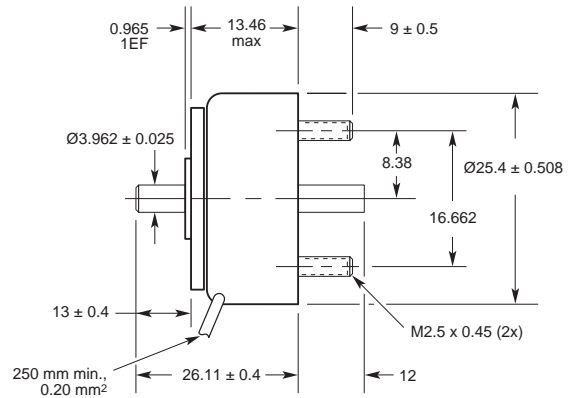

Size 2EF/2EC

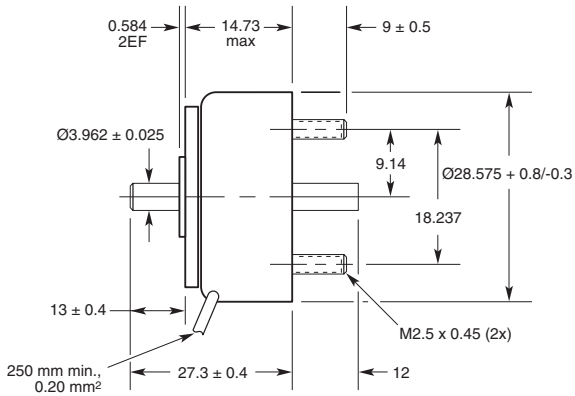

Size 3EF/3EC

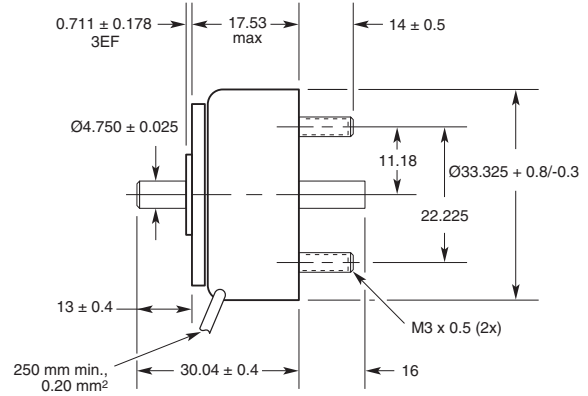

LINEAR Low Profile

All specifications subject to change without notice.

# Ledex<sup>®</sup> Low Profile Dimensions

mm

All solenoids are illustrated in energised state

## Size 4EF/4EC

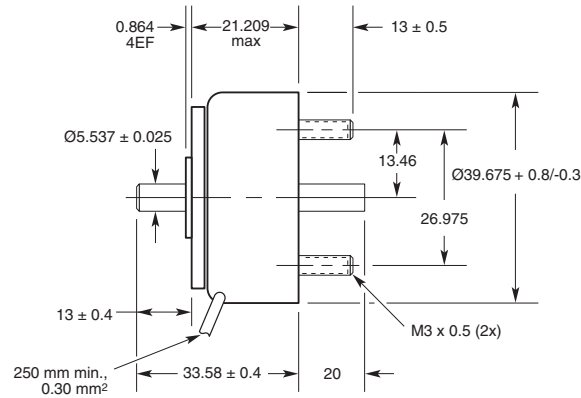

## Size 5SF

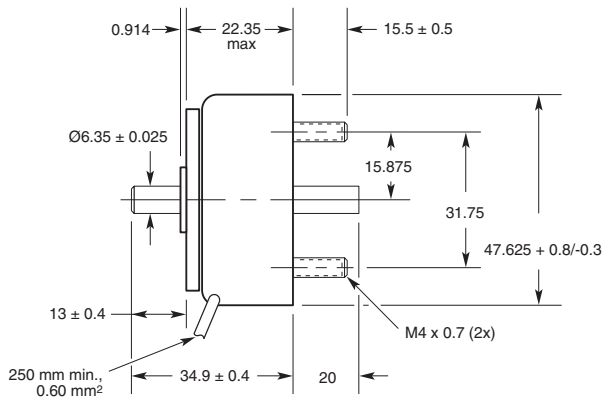

## Size 5EC

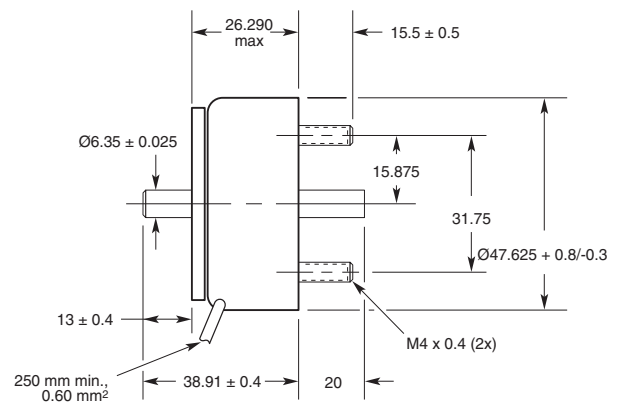

LINEAR Low Profile

All specifications subject to change without notice.

# Ledex® Low Profile Dimensions

mm

All solenoids are illustrated in energised state

Size 6SF

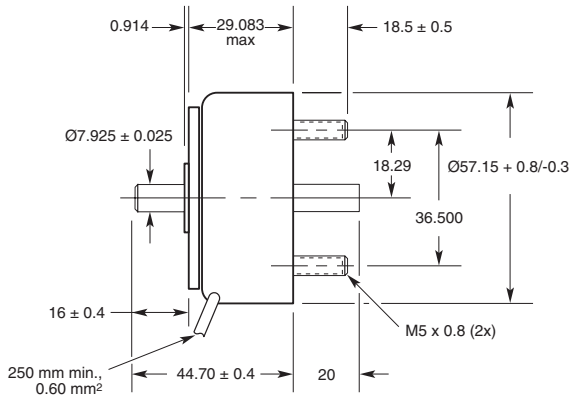

Size 6EC

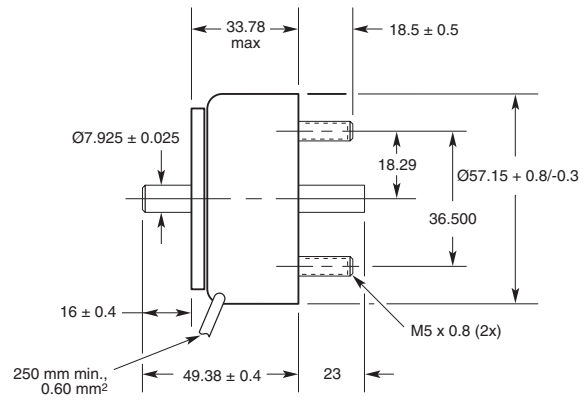

Size 7EC

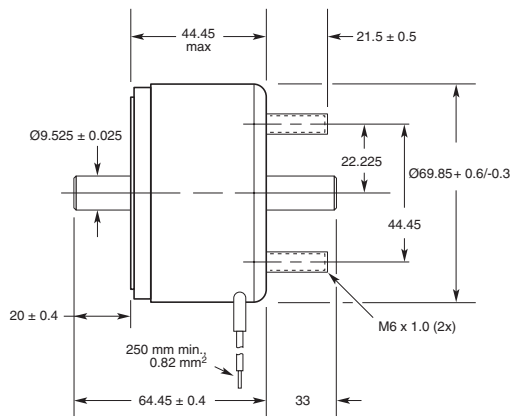

Size 8EC

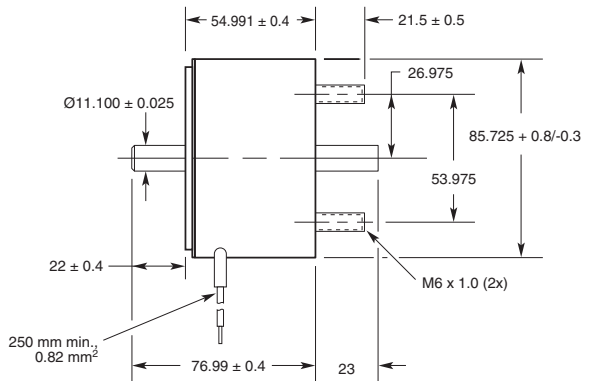

LINEAR Low Profile

All specifications subject to change without notice.

## Ledex® Open Frame Solenoids

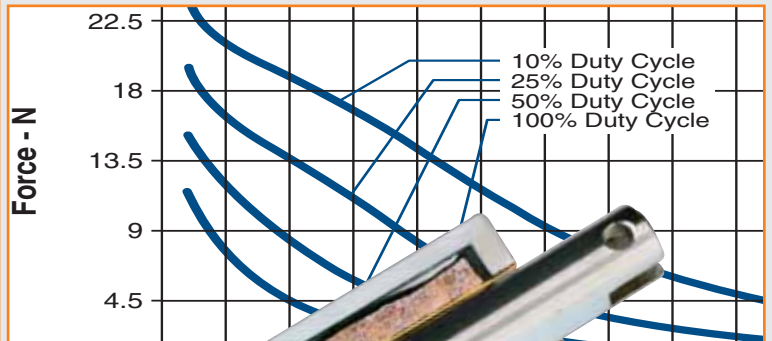

# Ledex® Open Frame Solenoids

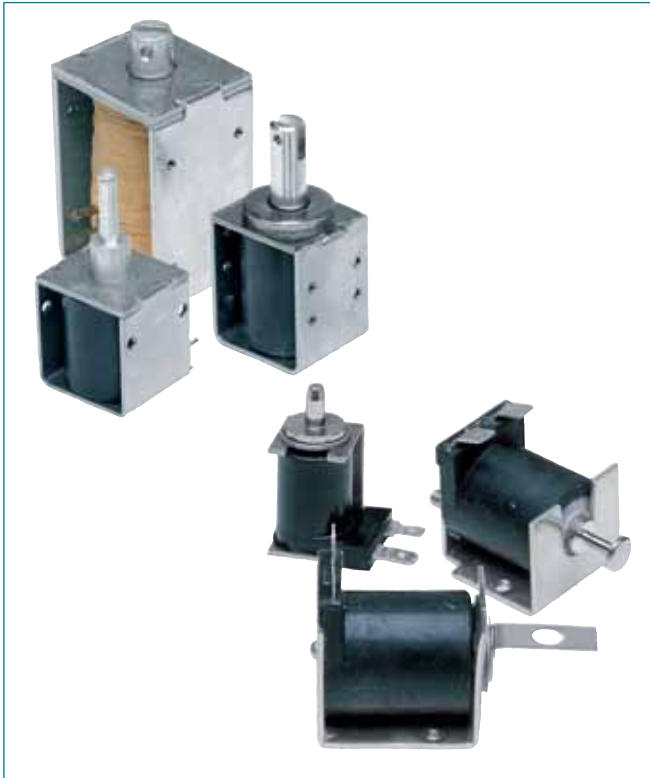

- Low cost, high volume products
- Strokes to 32 mm
- Custom design work is our strength

## Applications

- Printers
- Coin dispensers
- Security door locks
- Storage/retrieval systems
- PC board insertion equipment
- Vending

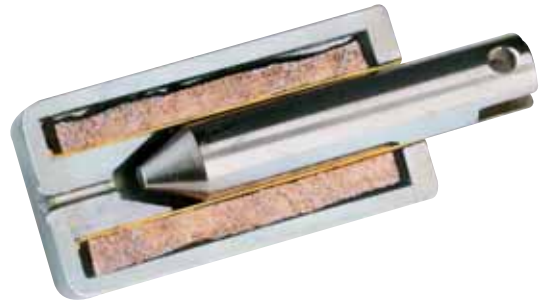

All catalogue products manufactured after April 1, 2006 are RoHS Compliant

The open frame solenoid is the simplest solenoid device consisting of an open iron frame, an overmolded or taped coil, and a movable plunger in the centre of the coil. Open frame solenoids are the most economical of all the solenoid types, and are typically selected for applications in which extremely long life and precise positioning are not critical.

Applications for Ledex® DC open frame devices are numerous. As with all types of solenoids, open frame models are well suited for applications which require either locking or latching functions.

Applications for DC open frame solenoids include residential and commercial door locks, credit card key “smart” locks, pharmaceutical compartment locks, circuit breakers, pinch valves, and many more.

## Principle of Operation

The open frame solenoid consists of an open iron frame, a coil, and a movable plunger in the centre of the coil.

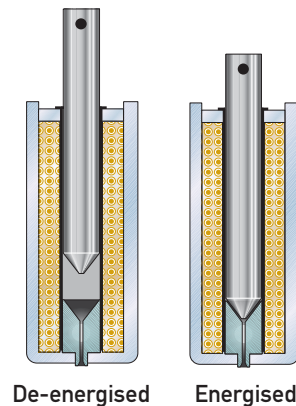

## Selection Overview

Use the selection charts on the following page to determine which model offers the desired performance and mechanical specifications.

Refer to the individual frame size specification pages for complete performance and mechanical data.

Even with our many standard solenoid designs, our customers often require a product with unique features or performance capabilities. If you don't find what you're looking for in the catalogue, please give us a call and talk to one of our application engineers.

# Ledex® Open Frame Solenoids

## Design Considerations

### Construction

Open frame solenoids are designed with two frame styles, the C Frame style, in which the coil is enclosed on one side, and the Box Frame style in which the coil is enclosed on two sides. The Box Frame style provides slightly higher force output and is more rugged in design.

Tapped mounting holes are used for easy installation and interchangeability.

Most models have slotted and cross drilled plungers for easy load attachment.

The plunger is plated for corrosion resistance, and provides a low coefficient of friction and long life.

Over molded coils are available in both Box Frame and C Frame solenoids and offer excellent protection from moisture and humidity. Some solenoids are UL recognised. Most have UL recognised coil insulation systems.

### Life

When selecting an open frame solenoid, as with any other solenoid style, it is important to consider the effects of heat, since an increase in coil temperature reduces the work output and the life of the unit. Standard life is 50,000 to 100,000 operations. Consult the factory for longer life of 500,000 or more cycles, and other special requirements.

### Duty Cycle

Duty cycle is determined by solenoid ON time/(ON + OFF time).

For example: a solenoid is actuated for 30 seconds, then off for 90 seconds.  
 $30 \text{ sec ON} / (30 \text{ Sec ON} + 90 \text{ sec OFF}) = 30/120 = 1/4$  or 25% duty cycle.

### Performance Curves

The Force/Stroke performance curves in this section serve as guides to determine the solenoid size needed to produce a desired force at a given stroke, duty cycle, and power source. All Force/Stroke curves are performed under standard test conditions: ambient temperature of 20°C. A design safety factor of 1.5 to 1.5 is recommended. For example, when a 20 N pull force is required, select a model with a safety factor of 1.5 to 1.5 times (26.3 N).

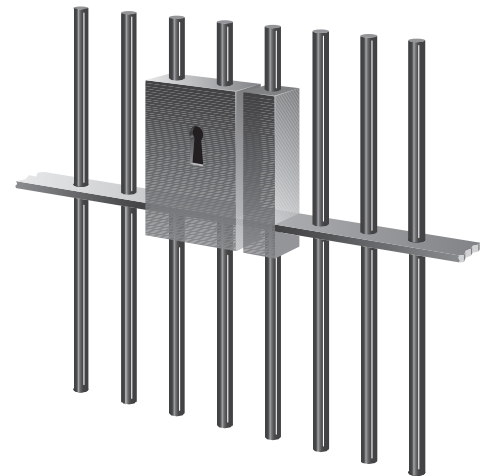

LINEAR Open Frame

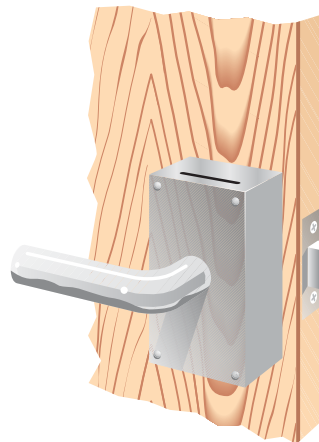

# Ledex® Open Frame Solenoids

## On-Off DC Open Frame Solenoids

DC actuated units are available in box frame and C frame design styles in a variety of models and sizes.

Models are available for continuous use and intermittent duty.

For low duty cycle applications, consider a magnetic latching open frame.



**Box Frame**

This solenoid has a 4-sided closed box frame and solid plunger and is, therefore, more electrically efficient than the C Frame solenoid. The closed, box frame also provides improved mechanical strength.



**C Frame**

C Frame solenoids consist of a formed C-shaped steel frame and solid plunger. Therefore, these solenoids are less efficient and less costly than their Box Frame counterparts.

LINEAR Open Frame

Size	Frame Type	Coil Type <sup>(1)</sup>	Height (mm)	Width (mm)	Length (mm)	Max. Stroke (mm)	Nominal Stroke (mm)	Typical Force (N)		Page
								Nominal Stroke and 100% Rated Voltage @ 100% Duty	25% Duty	
B4HDM	Box	OM	41.4	36.8	55.4	25.4	12.7	3.6	15.6	H6
B11M	Box	OM	30.0	23.9	47.2	20.3	10.2	0.9	4.4	H7
B14M ●	Box	T	25.9	20.1	36.8	15.2	5.1	2.2	8.5	H8
B16M ●	Box	T	12.2	9.8	25.1	3.8	1.3	0.4	1.3	H10
B17M ●	Box	T	15.0	13.0	24.1	4.6	1.3	0.9	2.7	H12
B20M ●	Box	T	23.9	20.6	29.0	12.7	6.4	0.4	1.8	H14
B21M	Box	T	33.3	33.3	30.5	12.7	6.4	2.7	9.8	H15
B22M	Box	OM	37.3	33.3	40.9	25.4	10.2	2.7	9.8	H16
B27M	Box	T	28.9	25.4	41.4	15.2	5.1	4.9	15.1	H18
B41M	Box	T	51.6	43.9	77.5	25.4	12.7	13.3	48.9	H19
B75M ●	Box	T	27.9	25.4	41.4	15.2	5.1	4.9	15.1	H20
C5M ●	C	T	11.7	10.4	23.9	5.1	1.3	3.1	0.9	H21
C8M ●	C	OM	20.6	19.1	28.7	12.7	6.4	0.2	1.3	H23
C9M	C	T	31.8	35.1	26.9	12.7	6.4	1.3	4.4	H24
C15M ●	C	T	25.4	26.9	29.0	12.7	6.4	0.4	2.7	H25
C26M	C	OM	26.9	21.6	43.9	19.1	12.7	0.4	2.2	H26
C33M	C	OM	29.0	33.3	34.5	12.7	6.4	1.3	4.9	H27
C34M	C	OM	36.5	33.3	42.2	25.4	12.7	0.9	4.4	H28

<sup>(1)</sup> OM = Overmolded; T = Taped

● Well-suited for battery operation.



See the "Battery Operated Solenoids" section for complete information.

All catalogue products manufactured after April 1, 2006 are RoHS Compliant

All specifications subject to change without notice.

# Ledex® Open Frame Solenoids

## Magnetic Latching DC Open Frame Solenoids

Magnetic latching solenoids are designed for low duty cycle applications where the solenoid's energised position is needed for an extended period of time.

When power is applied to the solenoid, the plunger moves to its energised position. The plunger latches magnetically in this position and remains there, consuming no power, until a negative

electrical pulse is applied to allow the plunger to unlatch.

The reverse voltage applied is dependent on the load attached to the plunger but must be well below the initial energizing value.

While continuous duty, on/off solenoids tend to develop heat, magnetic latching solenoids do not since no power is consumed in the energised state.



Since magnetic latching solenoids are typically used in low duty cycle applications, they are also perfect candidates for battery operation. These products are therefore catalogued as standard as low as 3-6 volts.

Typical applications for magnetic latching solenoids include door closers, locks, latches and security devices. Almost any solenoid type can be developed as a magnetic latching version. We offer open frame and tubular varieties as catalogue standard products.

Size	Frame Type	Coil Type <sup>(1)</sup>	Height (mm)	Width (mm)	Length (mm)	Max. Stroke (mm)	Nominal Stroke (mm)	Typical Force (N)		Page
								Nominal Stroke <sup>(2)</sup> and 100% Rated Voltage @ 25% Duty		
B14M-L ●	Box - Latching	T	25.9	20.1	36.8	15.2	2.5	8.9		H9
B16M-L ●	Box - Latching	T	12.2	9.9	25.1	3.8	1.3	0.7		H11
B17M-L ●	Box - Latching	T	15.0	13.0	28.4	4.1	2.0	0.9		H13
B22M-L	Box - Latching	OM	37.3	33.3	40.9	8.9	2.5	14.7		H17
C5M-L ●	C - Latching	T	11.7	10.4	23.9	5.1	1.3	1.8		H22

<sup>(1)</sup> OM = Overmolded; T = Taped

<sup>(2)</sup> Using flat face plunger

- Well-suited for battery operation.



See the "Battery Operated Solenoids" section for complete information.

LINEAR Open Frame

All catalogue products manufactured after April 1, 2006 are RoHS Compliant

All specifications subject to change without notice.

# Ledex® Box Frame Size B4HDM — DC Operation

Part Number: B4HDM -  - M-36

All catalogue products manufactured after April 1, 2006 are RoHS Compliant

Select from performance chart below

## Specifications

Continuous Duty Cycle	100% at 20°C ambient temperature
Intermittent Duty Cycle	See below
Holding Force	52 N at 20°C
Coil Insulation	Class "A": 105°C max. temperature standard. Other temperature classes are available
Coil Termination	3/16" QC
Plunger Weight	66.6 g
Total Weight	382.7 g
Dimensions	See page H29

## Performance

Maximum Duty Cycle	100%	50%	25%	10%
Maximum ON Time (sec) when pulsed continuously	∞	83	34	13
Maximum ON Time (sec) for single pulse	∞	609	207	66
Watts (@ 20°C)	12.5	25	50	125
Ampere Turns (@ 20°C)	1536	2174	3073	4860

### Coil Data

Part Number	Resistance (@20°C)	Ref # Turns	VDC (Nom)	VDC (Nom)	VDC (Nom)	VDC (Nom)
B4HDM-255-M-36	2.94	754	6	8.5	12	19
B4HDM-254-M-36	11.42	1467	12	17	24	38
B4HDM-253-M-36	46.83	2964	24	34	48	76
B4HDM-252-M-36	181	5724	48	68	96	152
B4HDM-251-M-36	1157	14239	120	170	240	380

### NOTES:

- All data is typical.
- Force testing is done with the solenoid in the horizontal position.
- All data reflects operation with no heatsink.
- Magnetic latching versions available. Pull versions standard; push versions available.
- Other coil terminations available.
- All specifications subject to change without notice.

## Typical Force @ 20°C

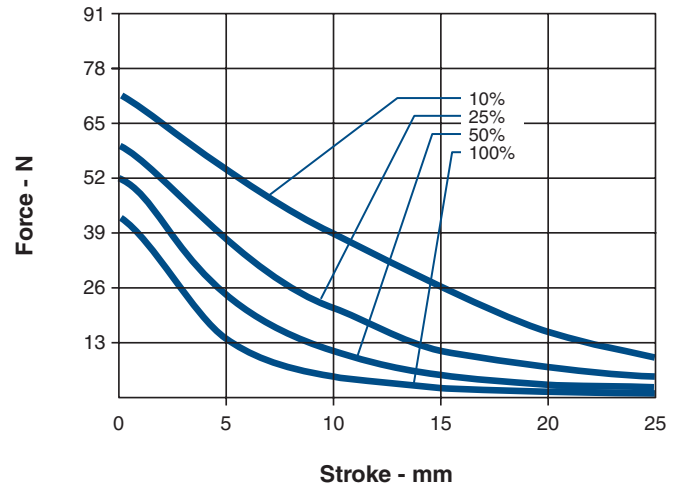

## How to Order

Select the part number from the table provided. (For example, to order a 25% duty cycle unit rated at 48 VDC, specify B4HDM-253-M-36.

Please see [www.ledex.com](http://www.ledex.com) (click on Stock Products tab) for our list of stock products available through our distributors.

# Ledex® Box Frame Size B11M — DC Operation

Part Number: B11M - **XXX** - M-36

All catalogue products manufactured after April 1, 2006 are RoHS Compliant

Select from performance chart below

## Specifications

Continuous Duty Cycle	100% at 20°C ambient temperature
Intermittent Duty Cycle	See below
Holding Force	15.5 N at 20°C
Coil Insulation	Class "A": 105°C max. temperature standard. Other temperature classes are available
Coil Termination	3/16" QC
Plunger Weight	17.0 g
Total Weight	144.5 g
Dimensions	See page H29

## Performance

Maximum Duty Cycle	100%	50%	25%	10%		
Maximum ON Time (sec) when pulsed continuously	∞	50	16	6		
Maximum ON Time (sec) for single pulse	∞	450	172	53		
Watts (@ 20°C)	8.5	17	34	85		
Ampere Turns (@ 20°C)	1317	1866	2634	4170		
Coil Data						
Part Number	Resistance (@20°C)	Ref # Turns	VDC (Nom)	VDC (Nom)	VDC (Nom)	VDC (Nom)
B11M-255-M-36	4.12	916	6	8.5	12	19
B11M-254-M-36	17.26	1783	12	17	24	38
B11M-253-M-36	65.76	3601	24	34	48	76
B11M-252-M-36	253.51	6930	48	68	96	152
B11M-251-M-36	1538	16548	120	161	229	361

### NOTES:

- All data is typical.
- Force testing is done with the solenoid in the horizontal position.
- All data reflects operation with no heatsink.
- Magnetic latching versions available. Pull versions standard; push versions available.
- Other coil terminations available.
- All specifications subject to change without notice.

## Typical Force @ 20°C

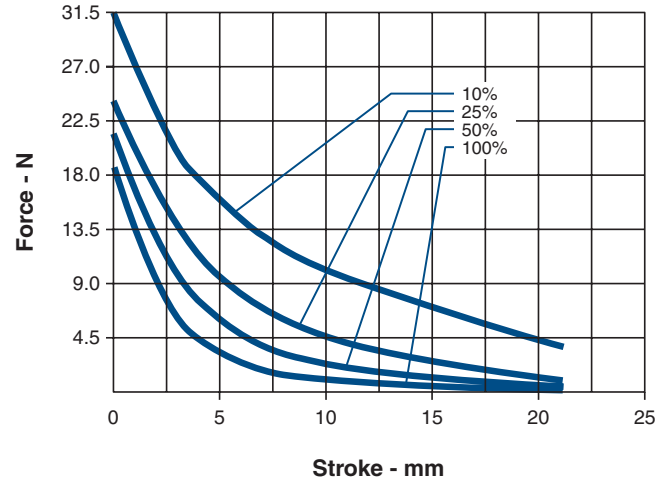

## How to Order

Select the part number from the table provided. (For example, to order a 25% duty cycle unit rated at 48 VDC, specify B11M-253-M-36.

Please see [www.ledex.com](http://www.ledex.com) (click on Stock Products tab) for our list of stock products available through our distributors.

LINEAR Open Frame

# Ledex® Box Frame Size B14M — DC Operation

Part Number: B14M - **XXX** - B- 1

All catalogue products manufactured after April 1, 2006 are RoHS Compliant

Select from performance chart below

## Specifications

Continuous Duty Cycle	100% at 20°C ambient temperature
Intermittent Duty Cycle	See below
Holding Force	15.6 N at 20°C
Coil Insulation	Class " B": 130°C max.
Coil Termination	250 mm PVC lead wires
Plunger Weight	12 g
Total Weight	90 g
Dimensions	See page H30

- Well-suited for battery operation.



See the "Battery Operated Solenoids" section for complete information.

## Performance

Maximum Duty Cycle	100%	50%	25%	10%
Maximum ON Time (sec) when pulsed continuously	∞	100	36	7
Maximum ON Time (sec) for single pulse	∞	480	180	45
Watts (@ 20°C)	5.2	10.4	20.8	52.2
Ampere Turns (@ 20°C)	750	1060	1500	2370

### Coil Data

Part Number	Resistance (@20°C)	Ref # Turns	VDC (Nom)	VDC (Nom)	VDC (Nom)	VDC (Nom)
B14M-255-B-1	6.9	871	6	8.5	12	19
B14M-254-B-1	28.6	1791	12	17	24	38
B14M-253-B-1	110	3450	24	34	48	76

### NOTES:

- All data is typical.
- Force testing is done with the solenoid in the horizontal position.
- All data reflects operation with no heatsink.
- Other coil terminations available.
- All specifications subject to change without notice.

## Typical Force @ 20°C

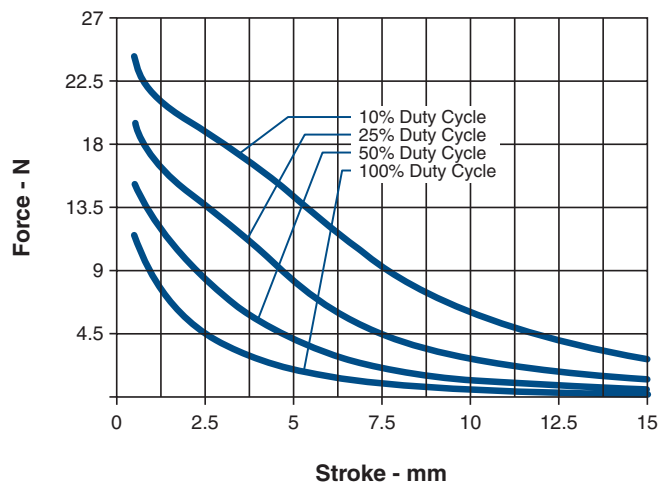

## How to Order

Select the part number from the table provided. (For example, to order a 25% duty cycle unit rated at 48 VDC, specify B14M-253-B-1.

Please see [www.ledex.com](http://www.ledex.com) (click on Stock Products tab) for our list of stock products available through our distributors.

Force values for reference only.

All specifications subject to change without notice.

# Ledex® Box Frame Size B14M-L — DC Operation

## Magnetic Latching

Part Number: B14M - L - **X** **XX** - B- 4

Coil Selection  
(from performance chart below)

Pole Configuration  
1 Flat Face  
2 50° Conical

All catalogue products manufactured after April 1, 2006 are RoHS Compliant

Well-suited for battery operation.



See the "Battery Operated Solenoids" section for complete information.

### Specifications

Operation	Pull
Dielectric Strength	500 VRMS for one second
Unlatch Voltage	See schematic and coil data below
Magnet Hold Force*	
Flat Face:	9.3 N (with return spring)
50° Conical:	5.6 N (with return spring)
Coil Insulation	Class "B": 130°C max. (standard); other temperature classes available
Coil Termination	250 mm PVC lead wires
Spring Force	0.6 N/mm; 0.8 N latched position
Plunger Pole Face	Flat face with return spring 50° conical with return spring (other options available)
Plunger Weight	14.2 g
Total Weight	95.9 g
Dimensions	See page H30

\*In no power, latched position

Maximum Duty Cycle	Unlatched			
	Voltage	50%	25%	10%
Maximum ON Time (sec) when pulsed continuously	∞	100	36	7
Maximum ON Time (sec) for single pulse	∞	480	180	45
Watts (@ 20°C)	5.2	10.4	20.8	52.2
Ampere Turns (@ 20°C)	750	1060	1500	2370

Coil Data						
Part Number	Resistance (@20°C)	Ref # Turns	Unlatch VDC	VDC (Nom)	VDC (Nom)	VDC (Nom)
B14M-L-X58-B-4	1.93	421	3	4	6	10
B14M-L-X55-B-4	6.90	871	6	8.5	12	19
B14M-L-X56-B-4	17.40	1228	9	13	18	29
B14M-L-X54-B-4	28.60	1791	12	17	24	38
B14M-L-X53-B-4	110.00	3450	24	34	48	76

### Coil Polarity

Latch: A+ B-  
Unlatch: A- B+

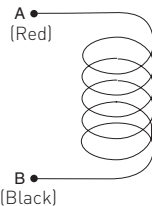

### NOTES:

- All data is typical.
- Force testing is done with the solenoid in the horizontal position.
- All data reflects operation with no heatsink.
- Other coil terminations available.
- All specifications subject to change without notice.

Force values for reference only.

### Typical Force @ 20°C – Flat Face Armature (net with spring)

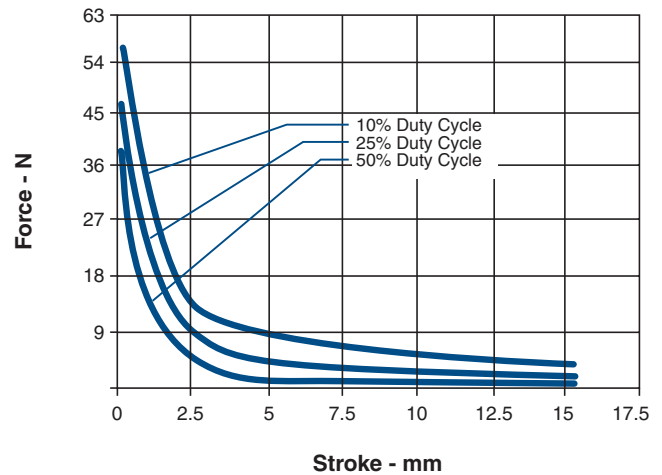

### Typical Force @ 20°C – 50° Conical Armature (net with spring)

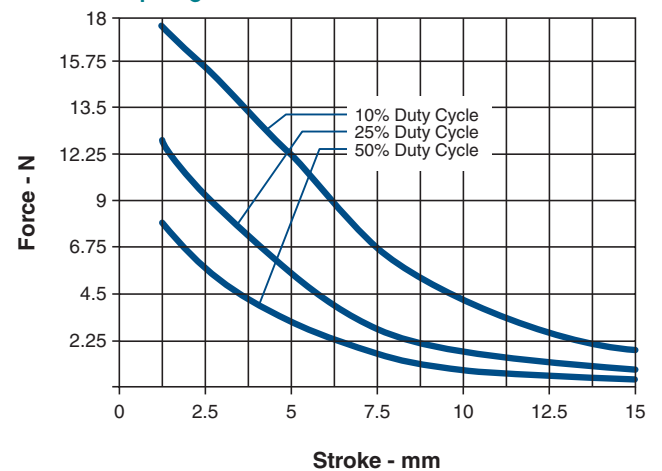

### How to Order

Select the part number from the table provided. (For example, to order a 25% duty cycle unit rated at 48 VDC with a 50° Conical Armature, specify B14M-L-253-B-4.

Please see [www.ledex.com](http://www.ledex.com) (click on Stock Products tab) for our list of stock products available through our distributors.

All specifications subject to change without notice.

# Ledex® Box Frame Size B16M — DC Operation

Part Number: B16M - **XXX** - B- 1

All catalogue products manufactured after April 1, 2006 are RoHS Compliant

Select from performance chart below

## Specifications

Continuous Duty Cycle	100% at 20°C ambient temperature
Intermittent Duty Cycle	See below
Holding Force	3.99 N at 20°C
Coil Insulation	Class "B": 130°C max.
Coil Termination	Lead wires
Plunger Weight	2.6 g
Total Weight	12.5 g
Dimensions	See page H31

● Well-suited for battery operation.



See the "Battery Operated Solenoids" section for complete information.

## Performance

Maximum Duty Cycle	100%	50%	25%	10%
Maximum ON Time (sec) when pulsed continuously	∞	40	15	5
Maximum ON Time (sec) for single pulse	∞	253	78	19
Watts (@ 20°C)	1.43	2.86	5.72	14.3
Ampere Turns (@ 20°C)	270	383	575	855

### Coil Data

Part Number	Resistance (@20°C)	Ref # Turns	VDC (Nom)	VDC (Nom)	VDC (Nom)	VDC (Nom)
B16M-258-B-1	6.35	531	3	4.3	6	9.5
B16M-256-B-1	54.2	1644	9	12.5	17.6	27.8
B16M-255-B-1	22.71	1100	6	8.5	12	19
B16M-254-B-1	100.79	2035	12	17	24	38
B16M-253-B-1	394.5	3944	24	34	48	76
B16M-252-B-1	1630	9827	48	68	96	153

### NOTES:

- All data is typical.
- Force testing is done with the solenoid in the horizontal position.
- All data reflects operation with no heatsink.
- Other coil terminations available.
- All specifications subject to change without notice.

## Typical Force @ 20°C

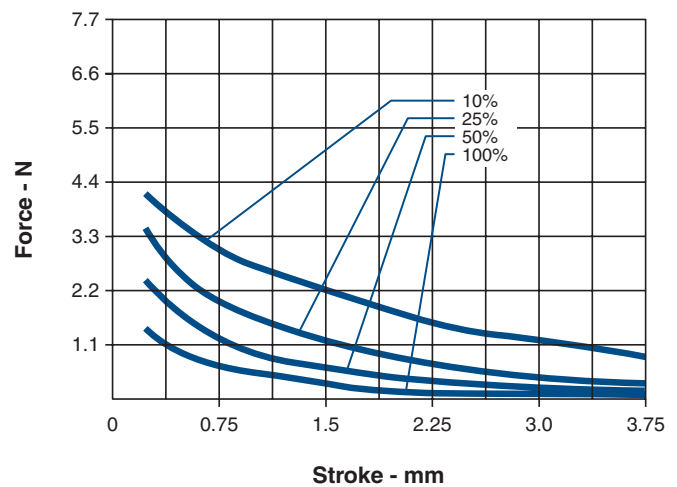

## How to Order

Select the part number from the table provided. (For example, to order a 25% duty cycle unit rated at 48 VDC, specify B16M-253-B-1.

Please see [www.ledex.com](http://www.ledex.com) (click on Stock Products tab) for our list of stock products available through our distributors.

Force values for reference only.

All specifications subject to change without notice.

# Ledex® Box Frame Size B16M-L — DC Operation

## Magnetic Latching

Part Number: B16M - L - **X** **XX** - B-3

Coil Selection  
(from performance chart below)

Pole Configuration  
1 Flat Face

All catalogue products manufactured after April 1, 2006 are RoHS Compliant

Well-suited for battery operation.



See the "Battery Operated Solenoids" section for complete information.

### Specifications

Operation	Pull
Dielectric Strength	500 VRMS for one second
Unlatch Voltage	See schematic and coil data below
Magnet Hold Force*	1.8 N (with return spring)
Coil Insulation	Class " B": 130°C max. (standard); other temperature classes available
Coil Termination	250 mm PVC lead wires
Spring Force	0.2 N; 0.3 N latched position
Plunger Pole Face	Flat face (other options available)
Plunger Weight	2.46 g
Total Weight	10.12 g
Dimensions	See page H31

\*In no power, latched position.

### Typical Force @ 20°C (Net, with Spring)

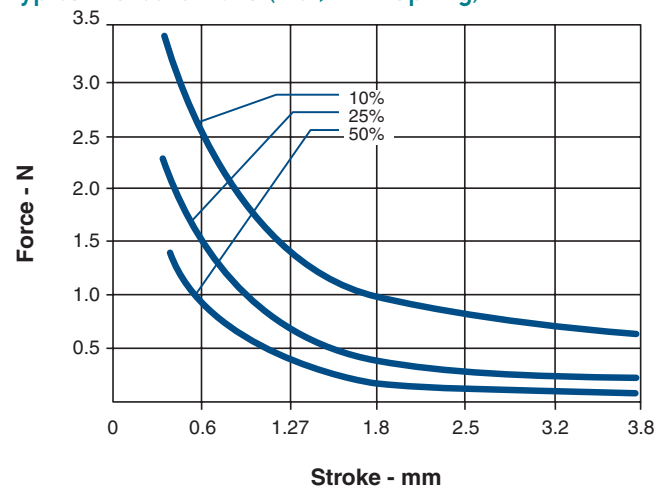

### Performance

Maximum Duty Cycle	Unlatched			
	Voltage	50%	25%	10%
Maximum ON Time (sec)	n/a	253	78	19
Watts (@ 20°C)	1.43	2.86	5.72	14.3
Ampere Turns (@ 20°C)	270	383	575	855

### Coil Data

Part Number	Resistance (@20°C)	Ref # Turns	Unlatch VDC	VDC (Nom)	VDC (Nom)	VDC (Nom)
B16M-L-158-B-3	6.35	531	3	4.3	6	9.5
B16M-L-155-B-3	22.71	1100	6	8.5	12	19
B16M-L-156-B-3	54.20	1644	9	12.5	17.6	27.8
B16M-L-154-B-3	100.79	2035	12	17	24	38
B16M-L-153-B-3	394.50	3944	24	34	48	76
B16M-L-152-B-3	1630.00	9827	48	68	96	153

### Coil Polarity

Latch: A+ B-  
Unlatch: A- B+

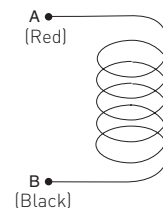

### How to Order

Select the part number from the table provided. (For example, to order a 25% duty cycle unit rated at 48 VDC, specify B16M-L-155-B-5.

Please see [www.ledex.com](http://www.ledex.com) (click on Stock Products tab) for our list of stock products available through our distributors.

### NOTES:

- All data is typical.
- Force testing is done with the solenoid in the horizontal position.
- All data reflects operation with no heatsink.
- Other coil terminations available.
- All specifications subject to change without notice.

Force values for reference only.

All specifications subject to change without notice.

LINEAR Open Frame

# Ledex® Box Frame Size B17M — DC Operation

Part Number: B17M - **XXX** - A- 1

All catalogue products manufactured after April 1, 2006 are RoHS Compliant

Select from performance chart below

## Specifications

Continuous Duty Cycle	100% at 20°C ambient temperature
Intermittent Duty Cycle	See below
Holding Force	3.9 N at 20°C
Coil Insulation	Class " B": 130°C max.
Coil Termination	250 mm PVC lead wires
Plunger Weight	2.84 g
Total Weight	18.4 g
Dimensions	See page H32

● Well-suited for battery operation.



See the "Battery Operated Solenoids" section for complete information.

## Performance

Maximum Duty Cycle	100%	50%	25%	10%
Maximum ON Time (sec) when pulsed continuously	∞	15	6	2
Maximum ON Time (sec) for single pulse	∞	112	36	10.5
Watts (@ 20°C)	1.6	3.2	6.4	16
Ampere Turns (@ 20°C)	292	414	584	923

Coil Data						
Part Number	Resistance (@20°C)	Ref # Turns	VDC (Nom)	VDC (Nom)	VDC (Nom)	VDC (Nom)
B17M-258-A-1	5.40	520	2.9	4	6	9
B17M-256-A-1	50.2	1624	9	12	18	28.3
B17M-255-A-1	21.93	1112	6	8.5	12	19
B17M-254-A-1	88.95	2219	12	17	24	38
B17M-253-A-1	337	3687	24	34	48	76
B17M-252-A-1	1465	9177	48	68	96	153

## NOTES:

1. All data is typical.
2. Force testing is done with the solenoid in the horizontal position.
3. All data reflects operation with no heatsink.
4. Other coil terminations available.
5. All specifications subject to change without notice.

## Typical Force @ 20°C

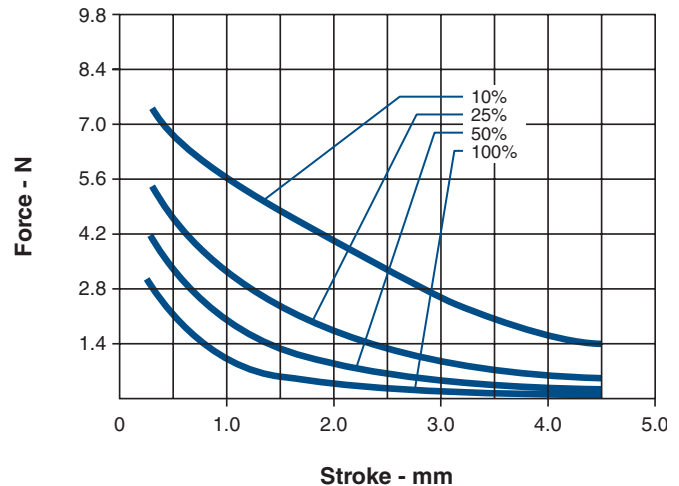

## How to Order

Select the part number from the table provided. (For example, to order a 25% duty cycle unit rated at 48 VDC, specify B17M-253-A-1.

Please see [www.ledex.com](http://www.ledex.com) (click on Stock Products tab) for our list of stock products available through our distributors.

Force values for reference only.

All specifications subject to change without notice.

# Ledex® Box Frame Size B17M-L — DC Operation

## Magnetic Latching

Part Number: B17M - L - **X** **XX** - B-3

Coil Selection  
(from performance chart below)

Pole Configuration  
1 Flat Face

All catalogue products manufactured after April 1, 2006 are RoHS Compliant

### Specifications

Operation	Pull
Dielectric Strength	500 VRMS for one second
Unlatch Voltage	See schematic and coil data below
Magnet Hold Force*	2.5 N (with return spring)
Coil Insulation	Class "B": 130°C max. (standard); other temperature classes available
Coil Termination	250 mm PVC lead wires
Spring Force	0.4 N/mm; 0.1 N latched position
Plunger Pole Face	Flat face (other options available)
Plunger Weight	2.46 g
Total Weight	19.85 g
Dimensions	See page H32

\*In no power, latched position.

Well-suited for battery operation.



See the "Battery Operated Solenoids" section for complete information.

### Performance

	Unlatched			
	Voltage	50%	25%	10%
Maximum Duty Cycle				
Maximum ON Time (sec)	n/a	112	36	10.5
Watts (@ 20°C)	1.6	3.2	6.4	16
Ampere Turns (@ 20°C)	292	414	584	923

#### Coil Data

Part Number	Resistance (@20°C)	Ref # Turns	Unlatch VDC	VDC (Nom)	VDC (Nom)	VDC (Nom)
B17M-L-158-B-3	5.40	520	3	4	6	9
B17M-L-155-B-3	21.93	1112	6	8.5	12	19
B17M-L-156-B-3	50.20	1624	9	12	18	28.3
B17M-L-154-B-3	88.95	2219	12	17	24	38
B17M-L-153-B-3	337.00	3687	24	34	48	76
B17M-L-152-B-3	1465.00	9177	48	68	96	153

#### NOTES:

- All data is typical.
- Force testing is done with the solenoid in the horizontal position.
- All data reflects operation with no heatsink.
- Other coil terminations available.
- All specifications subject to change without notice.

### Typical Force @ 20°C (Net, with Spring)

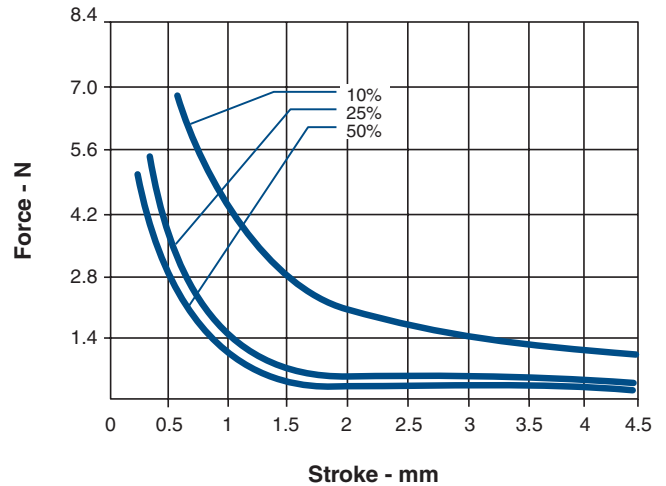

### Coil Polarity

Latch: A+ B-  
Unlatch: A- B+

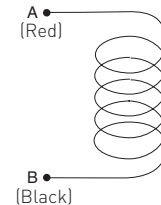

### How to Order

Select the part number from the table provided. (For example, to order a 25% duty cycle unit rated at 48 VDC, specify B17M-L-153-B-5.

Please see [www.ledex.com](http://www.ledex.com) (click on Stock Products tab) for our list of stock products available through our distributors.

Force values for reference only.

All specifications subject to change without notice.

# Ledex® Box Frame Size B20M — DC Operation

Part Number: B20M - **XXX** - A- 3

All catalogue products manufactured after April 1, 2006 are RoHS Compliant

Select from performance chart below

## Specifications

Continuous Duty Cycle	100% at 20°C ambient temperature
Intermittent Duty Cycle	See below
Holding Force	10.2 N at 20°C
Coil Insulation	Class " A": 105°C max.
Coil Termination	Lead wires
Plunger Weight	16.4 g
Total Weight	61.6 g
Dimensions	See page H33

## Performance

Maximum Duty Cycle	100%	50%	25%	10%
Maximum ON Time (sec) when pulsed continuously	∞	65	28	7
Maximum ON Time (sec) for single pulse	∞	190	80	28
Watts (@ 20°C)	4.5	9.0	18.0	45.0
Ampere Turns (@ 20°C)	429	608	858	1358

### Coil Data

Part Number	Resistance (@20°C)	Ref # Turns	VDC (Nom)	VDC (Nom)	VDC (Nom)	VDC (Nom)
B20M-255-A-3	8	572	6	8.5	12	19
B20M-254-A-3	32	1222	12	17	24	38
B20M-253-A-3	128	2269	24	34	48	76
B20M-252-A-3	512	4496	48	68	96	152
B20M-251-A-3	3200	10944	120	170	240	380

### NOTES:

1. All data is typical.
2. Force testing is done with the solenoid in the horizontal position.
3. All data reflects operation with no heatsink.
4. Other coil terminations available.
5. All specifications subject to change without notice.

## Typical Force @ 20°C

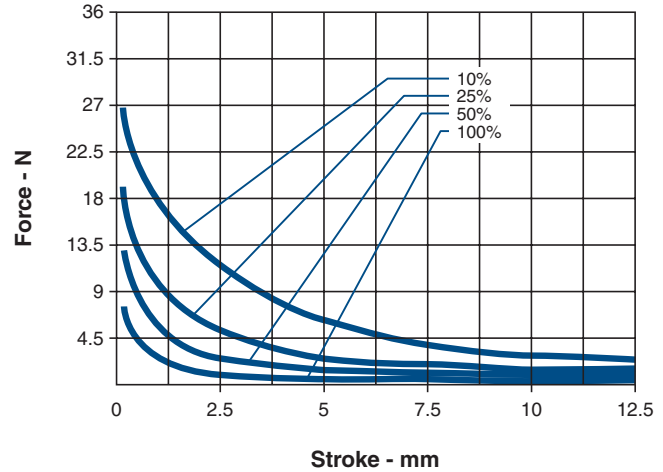

## How to Order

Select the part number from the table provided. (For example, to order a 25% duty cycle unit rated at 48 VDC, specify B20M-253-A-3.

Please see [www.ledex.com](http://www.ledex.com) (click on Stock Products tab) for our list of stock products available through our distributors.

# Ledex® Box Frame Size B21M — DC Operation

Part Number: B21M - **XXX** - A-3

All catalogue products manufactured after April 1, 2006 are RoHS Compliant

Select from performance chart below

## Specifications

Continuous Duty Cycle	100% at 20°C ambient temperature
Intermittent Duty Cycle	See below
Holding Force	36.9 N at 20°C
Coil Insulation	Class "A": 105°C max. temperature standard. Other temperature classes are available
Coil Termination	Lead wires
Plunger Weight	24.0 g
Total Weight	132.4 g
Dimensions	See page H33

## Performance

Maximum Duty Cycle	100%	50%	25%	10%
Maximum ON Time (sec) when pulsed continuously	∞	98	45	17
Maximum ON Time (sec) for single pulse	∞	338	115	36
Watts (@ 20°C)	8	16	32	80
Ampere Turns (@ 20°C)	869	1231	1738	2752

### Coil Data

Part Number	Resistance (@20°C)	Ref # Turns	VDC (Nom)	VDC (Nom)	VDC (Nom)	VDC (Nom)
B21M-255-A-3	4.5	660	6	8.5	12	19
B21M-254-A-3	18	1316	12	17	24	38
B21M-253-A-3	72	2631	24	34	48	76
B21M-252-A-3	288	5170	48	68	96	152
B21M-251-A-3	1800	12740	120	170	240	380

### NOTES:

- All data is typical.
- Force testing is done with the solenoid in the horizontal position.
- All data reflects operation with no heatsink.
- Magnetic latching versions available. Pull versions standard; push versions available.
- Other coil terminations available.
- All specifications subject to change without notice.

## Typical Force @ 20°C

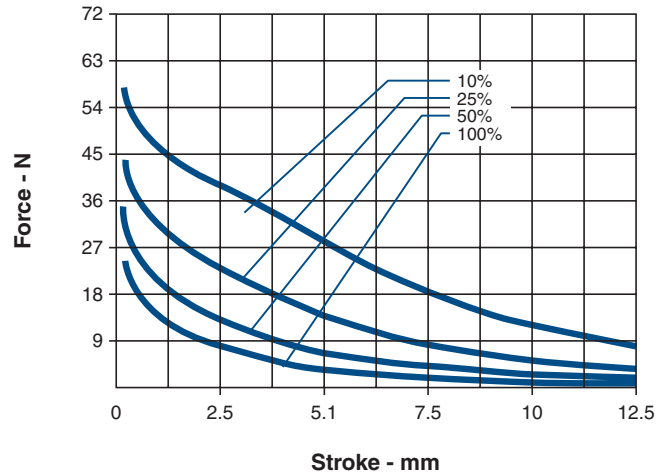

## How to Order

Select the part number from the table provided. (For example, to order a 25% duty cycle unit rated at 48 VDC, specify B21M-253-A-3.

Please see [www.ledex.com](http://www.ledex.com) (click on Stock Products tab) for our list of stock products available through our distributors.

LINEAR Open Frame

Force values for reference only.

All specifications subject to change without notice.

# Ledex® Box Frame Size B22M — DC Operation

Part Number: B22M - **XXX** - M-36

All catalogue products manufactured after April 1, 2006 are RoHS Compliant

Select from performance chart below

## Specifications

Continuous Duty Cycle	100% at 20°C ambient temperature
Intermittent Duty Cycle	See below
Holding Force	35.6 N at 20°C
Coil Insulation	Class "A": 105°C max. temperature standard. Other temperature classes are available
Coil Termination	3/16" QC
Plunger Weight	39.7 g
Total Weight	212.6 g
Dimensions	See page H34

## Performance

Maximum Duty Cycle	100%	50%	25%	10%
Maximum ON Time (sec) when pulsed continuously	∞	52	23	9
Maximum ON Time (sec) for single pulse	∞	485	167	47
Watts (@ 20°C)	9.9	19.8	39.6	99
Ampere Turns (@ 20°C)	1046	1482	2093	3314

### Coil Data

Part Number	Resistance (@20°C)	Ref # Turns	VDC (Nom)	VDC (Nom)	VDC (Nom)	VDC (Nom)
B22M-255-M-36	3.64	635	6	8.5	12	19
B22M-254-M-36	14.55	1300	12	17	24	38
B22M-253-M-36	58.18	2578	24	34	48	76
B22M-252-M-36	232.73	5103	48	68	96	152
B22M-251-M-36	1493	12744	120	172	240	385

### NOTES:

- All data is typical.
- Force testing is done with the solenoid in the horizontal position.
- All data reflects operation with no heatsink.
- Magnetic latching versions available. Pull versions standard; push versions available.
- Other coil terminations available.
- All specifications subject to change without notice.

## Typical Force @ 20°C

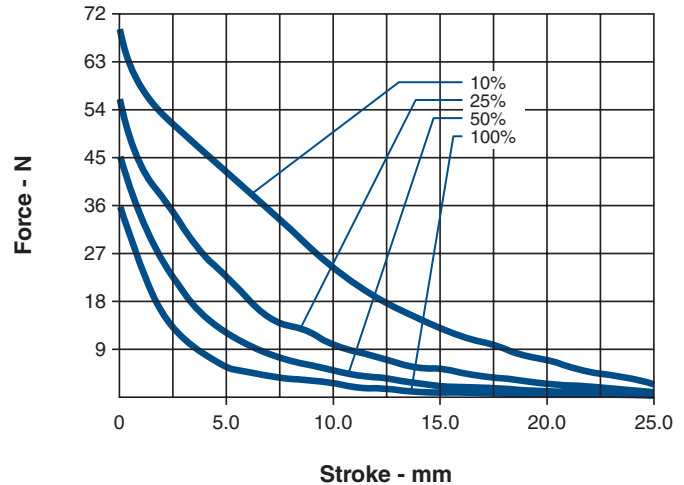

## How to Order

Select the part number from the table provided. (For example, to order a 25% duty cycle unit rated at 48 VDC, specify B22M-253-M-36.

Please see [www.ledex.com](http://www.ledex.com) (click on Stock Products tab) for our list of stock products available through our distributors.

# Ledex® Box Frame Size B22M-L — DC Operation

## Magnetic Latching

Part Number: B22M - L - X XX - M-36

Coil Selection  
(from performance chart below)

Pole Configuration  
1 Flat Face  
2 60° Conical

All catalogue products manufactured after April 1, 2006 are RoHS Compliant

### Specifications

Operation	Pull
Dielectric Strength	1500 VRMS for one second
Unlatch Voltage	See schematic and coil data below
Magnet Hold Force*	
Flat Face:	22 N (with return spring)
60° Conical:	4.5 N (with return spring)
Coil Insulation	Class "B": 130°C max. (standard); other temperature classes available
Coil Termination	3/16" QC
Spring Force	0.4 N/mm; 4.8 N latched position
Plunger Pole Face	Flat face with return spring 60° with return spring (other options available)
Plunger Weight	35.2 g
Total Weight	212.8 g
Dimensions	See page H34

\*In no power, latched position.

### Performance

Maximum Duty Cycle	Unlatched			
	Voltage	50%	25%	10%
Maximum ON Time (sec)	n/a	485	167	47
Watts (@ 20°C)	9.9	19.8	39.6	99
Ampere Turns (@ 20°C)	1046	1482	2093	3314

#### Coil Data

Part Number	Resistance (@20°C)	Ref # Turns	Unlatch VDC	VDC (Nom)	VDC (Nom)	VDC (Nom)
B22M-L-X55-M-36	3.64	635	6	8.5	12	19
B22M-L-X54-M-36	14.55	1300	12	17	24	38
B22M-L-X53-M-36	58.18	2578	24	34	48	76
B22M-L-X52-M-36	232.73	5103	48	68	96	152
B22M-L-X51-M-36	1493.00	12744	120	172	240	385

#### NOTES:

- All data is typical.
- Force testing is done with the solenoid in the horizontal position.
- All data reflects operation with no heatsink.
- Other coil terminations available.
- All specifications subject to change without notice.

Force values for reference only.

### Typical Force @ 20°C – 60° Armature (Net, with Spring)

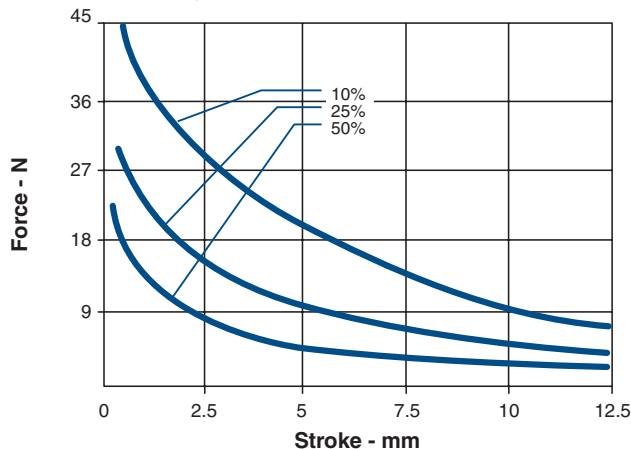

### Typical Force @ 20°C – Flat Face Armature (Net, with Spring)

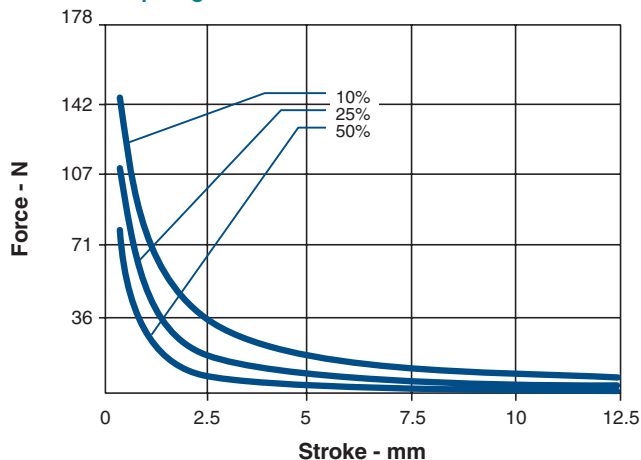

#### Coil Polarity

Latch: A+ B-  
Unlatch: A- B+

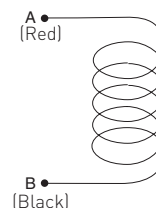

#### How to Order

Select the part number from the table provided. (For example, to order a 25% duty cycle flat face unit rated at 48 VDC, specify B22M-L-153-M-36.

Please see [www.ledex.com](http://www.ledex.com) (click on Stock Products tab) for our list of stock products available through our distributors.

All specifications subject to change without notice.

LINEAR Open Frame

# Ledex® Box Frame Size B27M — DC Operation

Part Number: B27M - **XXX** - A- 3

All catalogue products manufactured after April 1, 2006 are RoHS Compliant

Select from performance chart below

## Specifications

Continuous Duty Cycle	100% at 20°C ambient temperature
Intermittent Duty Cycle	See below
Holding Force	22.12 N at 20°C
Coil Insulation	Class "A": 105°C max. temperature standard. Other temperature classes are available
Coil Termination	250 mm PVC lead wires
Plunger Weight	20.4 g
Total Weight	90.7 g
Dimensions	See page H35

## Performance

Maximum Duty Cycle	100%	50%	25%	10%
Maximum ON Time (sec) when pulsed continuously	∞	190	62	19
Maximum ON Time (sec) for single pulse	∞	480	180	45
Watts (@ 20°C)	7.2	14.4	28.8	72.2
Ampere Turns (@ 20°C)	918	1300	1836	2907

### Coil Data

Part Number	Resistance (@20°C)	Ref # Turns	VDC (Nom)	VDC (Nom)	VDC (Nom)	VDC (Nom)
B27M-255-A-3	5	765	6	8.5	12	19
B27M-254-A-3	20	1533	12	17	24	38
B27M-253-A-3	80	3060	24	34	48	76
B27M-252-A-3	320	6120	48	68	96	152
B27M-251-A-3	2000	15300	120	170	240	380

### NOTES:

1. All data is typical.
2. Force testing is done with the solenoid in the horizontal position.
3. All data reflects operation with no heatsink.
4. Other coil terminations available.
5. All specifications subject to change without notice.

## Typical Force @ 20°C

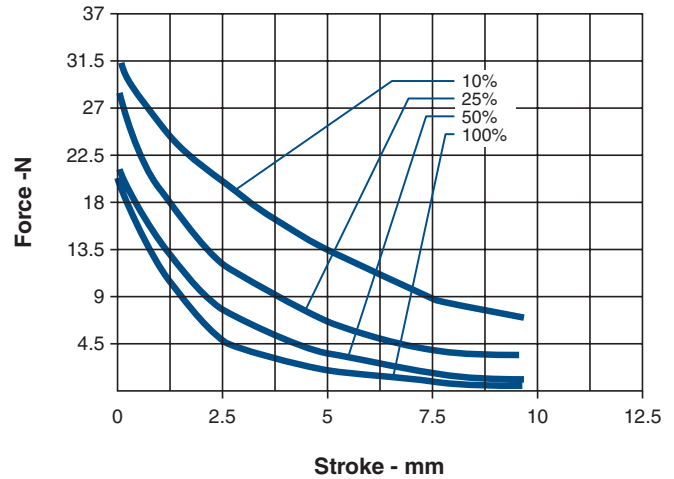

## How to Order

Select the part number from the table provided. (For example, to order a 25% duty cycle unit rated at 48 VDC, specify B27M-253-A-3.

Please see [www.ledex.com](http://www.ledex.com) (click on Stock Products tab) for our list of stock products available through our distributors.

# Ledex® Box Frame Size B41M — DC Operation

Part Number: B41M - **XXX** - B- 1

All catalogue products manufactured after April 1, 2006 are RoHS Compliant

Select from performance chart below

## Specifications

Continuous Duty Cycle	100% at 20°C ambient temperature
Intermittent Duty Cycle	See below
Holding Force	71.2 N at 20°C
Coil Insulation	Class "A": 105°C max. temperature standard . Other temperature classes are available
Coil Termination	Solder lugs
Plunger Weight	158.8 g
Total Weight	878.9 g
Dimensions	See page H35

## Performance

Maximum Duty Cycle	100%	50%	25%	10%
Maximum ON Time (sec) when pulsed continuously	∞	95	60	14
Maximum ON Time (sec) for single pulse	∞	1548	491	139
Watts (@ 20°C)	19	38	76	190
Ampere Turns (@ 20°C)	1981	2807	3963	6274

### Coil Data

Part Number	Resistance (@20°C)	Ref # Turns	VDC (Nom)	VDC (Nom)	VDC (Nom)	VDC (Nom)
B41M-255-B-1	1.84	608	6	8.5	12	19
B41M-254-B-1	7.67	1432	12	17	24	38
B41M-253-B-1	30.19	2814	24	34	48	76
B41M-252-B-1	121.5	5610	48	68	96	152
B41M-251-B-1	793.46	14259	120	173	240	388

### NOTES:

- All data is typical.
- Force testing is done with the solenoid in the horizontal position.
- All data reflects operation with no heatsink.
- Magnetic latching versions available. Pull versions standard; push versions available.
- Other coil terminations available.
- All specifications subject to change without notice.

## Typical Force @ 20°C

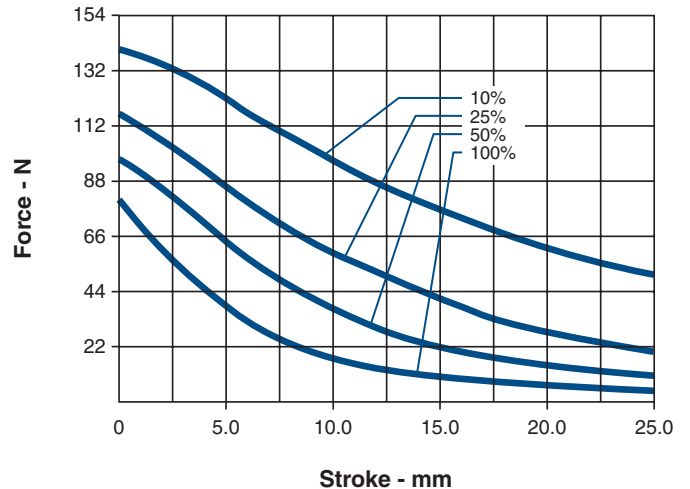

## How to Order

Select the part number from the table provided. (For example, to order a 25% duty cycle unit rated at 48 VDC, specify B41M-253-B-1.

Please see [www.ledex.com](http://www.ledex.com) (click on Stock Products tab) for our list of stock products available through our distributors.

LINEAR Open Frame

# Ledex® Box Frame Size B75M — DC Operation

Part Number: B75M - **XXX** - B-3

All catalogue products manufactured after April 1, 2006 are RoHS Compliant

Select from performance chart below

## Specifications

Continuous Duty Cycle	100% at 20°C ambient temperature
Intermittent Duty Cycle	See chart
Holding Force	20 N at 20°C
Coil Insulation	Class "B": 130°C max. temperature standard
Coil Termination	Lead wires
Plunger Weight	30 g
Total Weight	160 g
Dimensions	See page H36

Well-suited for battery operation.



See the "Battery Operated Solenoids" section for complete information.

## Performance

Maximum Duty Cycle	100%	50%	25%	10%
Maximum ON Time (sec) when pulsed continuously	∞	90	27	5
Maximum ON Time (sec) for single pulse	∞	436	144	36
Watts (@ 20°C)	6	12	24	60
Ampere Turns (@ 20°C)	800	1133	1500	2528

### Coil Data

Part Number	Resistance (@20°C)	Ref # Turns	VDC (Nom)	VDC (Nom)	VDC (Nom)	VDC (Nom)
B75M-255-B-3	5.9	800	6	8.4	11.9	18.8
B75M-254-B-3	24	1600	12	17	24	38
B75M-253-B-3	96	3280	24	34	48	76
B75M-252-B-3	384	6480	48	67.9	96	153

### NOTES:

- All data is typical.
- Force testing is done with the solenoid in the horizontal position.
- All data reflects operation with no heatsink.
- Magnetic latching versions available. Pull versions standard; push versions available.
- Other coil terminations available.
- All specifications subject to change without notice.

## Typical Force @ 20°C

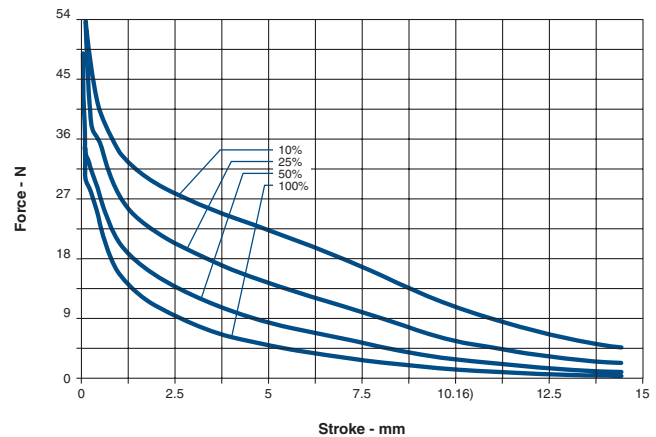

## How to Order

Select the part number from the table provided. (For example, to order a 25% duty cycle unit rated at 48 VDC, specify B75M-253-B-3.

Please see [www.ledex.com](http://www.ledex.com) (click on Stock Products tab) for our list of stock products available through our distributors.

Force values for reference only.

All specifications subject to change without notice.

# Ledex® C Frame Size C5M — DC Operation

Part Number: C5M - **XXX** - B- 1

All catalogue products manufactured after April 1, 2006 are RoHS Compliant

Select from performance chart below

## Specifications

Operation	Pull
Dielectric Strength	500 VRMS for one second
Continuous Duty Cycle	100% At 20°C ambient temperature
Intermittent Duty Cycle	See below
Coil Insulation	Class "B": 130°C max. temperature standard. Other temperature classes are available
Coil Termination	0.025 inch square pin terminals
Plunger Pole Face	60° conical
Plunger Weight	2.2 g
Total Weight	11.9 g
Dimensions	See page H37

## Performance

Maximum Duty Cycle	100%	50%	25%	10%
Maximum ON Time (sec)	∞	145	47	14
Watts (@ 20°C)	3	6	12	30
Ampere Turns (@ 20°C)	422	564	844	1268

### Coil Data

Part Number	Resistance (@20°C)	Ref # Turns	VDC (Nom)	VDC (Nom)	VDC (Nom)	VDC (Nom)
C5M-273-B-1	2.88	406	3	4	6	9
C5M-272-B-1	11.52	795	6	8	12	19
C5M-271-B-1	25.77	1222	9	12	18	28
C5M-270-B-1	48.65	1642	12	17	24	38
C5M-269-B-1	72.84	1968	15	21	30	47
C5M-268-B-1	152.20	2860	21	30	43	68
CM5-267-B-1	191.73	3202	24	34	48	76

### NOTES:

- All data is typical.
- Force testing is done with the solenoid in the horizontal position.
- All data reflects operation with no heatsink.
- Other coil terminations available.
- All specifications subject to change without notice.

- Well-suited for battery operation.



See the "Battery Operated Solenoids" section for complete information.

## Force (Gross, Without Spring)

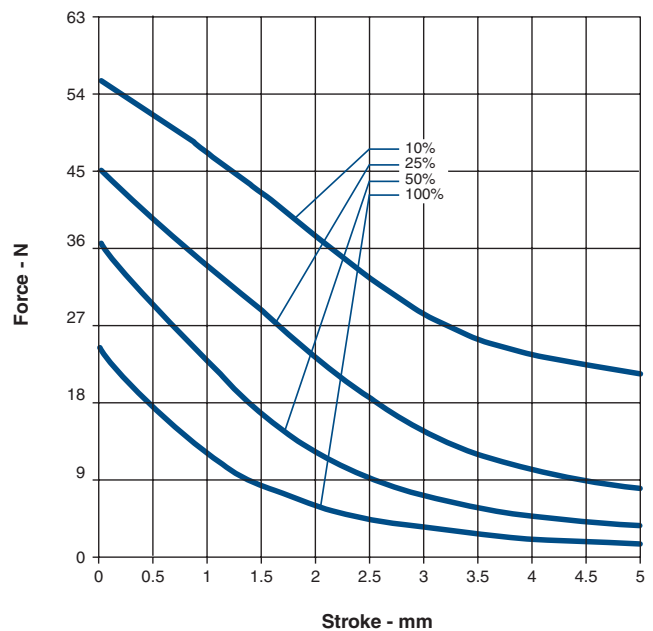

## How to Order

Select the part number from the table provided. (For example, to order a 25% duty cycle unit rated at 48 VDC, specify C5M-267-B-1.

Please see [www.ledex.com](http://www.ledex.com) (click on Stock Products tab) for our list of stock products available through our distributors.

LINEAR Open Frame

# Ledex® C Frame Size C5M-L— DC Operation

## Magnetic Latching

Part Number: C5M - L - **XXX** - B - 1

All catalogue products manufactured after April 1, 2006 are RoHS Compliant

Select from performance chart below

### Specifications

Operation	Pull
Dielectric Strength	500 VRMS for one second
Unlatch Voltage	See schematic and coil data below
Magnet Hold Force*	5.7 N (with return spring)
Coil Insulation	Class "B": 130°C max. temperature standard. Other temperature classes are available
Coil Termination	0.025 inch square pin terminals
Plunger Pole Face	Flat face with return spring (other options available upon request)
Spring Force	0.1 N/mm; 0.7 N latched position
Plunger Weight	2.8 g
Total Weight	11.9 g
Dimensions	See page H37

\*In no power, latched position.

### Performance

Maximum Duty Cycle	Unlatch Voltage			
	50%	25%	10%	
Maximum ON Time (sec)	∞	145	47	14
Watts (@ 20°C)	3	6	12	30
Ampere Turns (@ 20°C)	422	564	844	1268

#### Coil Data

Part Number	Resistance (@20°C)	Ref # Turns	VDC (Nom)	VDC (Nom)	VDC (Nom)	VDC (Nom)
C5M-L-273-B-1	2.88	406	3	4	6	9
C5M-L-272-B-1	11.52	795	6	8	12	19
C5M-L-271-B-1	25.77	1222	9	12	18	28
C5M-L-270-B-1	48.65	1642	12	17	24	38
C5M-L-269-B-1	72.84	1968	15	21	30	47
C5M-L-268-B-1	152.20	2860	21	30	43	68
C5M-L-267-B-1	191.73	3202	24	34	48	76

#### NOTES:

- All data is typical.
- Force testing is done with the solenoid in the horizontal position.
- All data reflects operation with no heatsink.
- Other coil terminations available.
- All specifications subject to change without notice.

Force values for reference only.

- Well-suited for battery operation.



See the "Battery Operated Solenoids" section for complete information.

### Force (Net, With Spring)

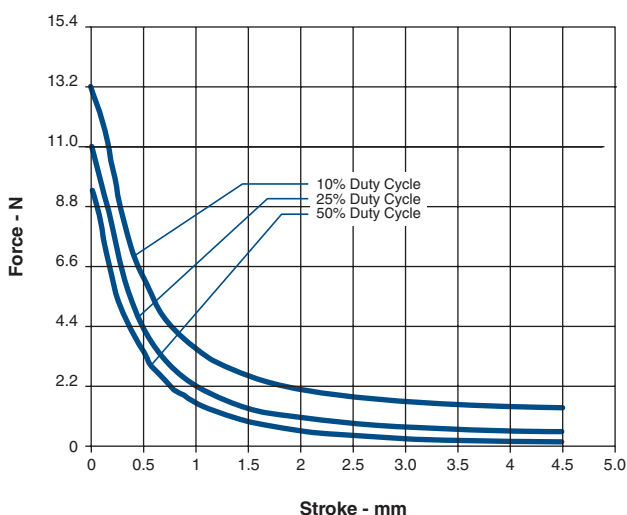

### Coil Polarity

Latch: A+ B-  
Unlatch: A- B+

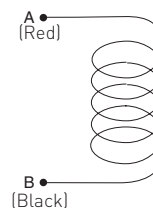

### How to Order

Select the part number from the table provided. (For example, to order a 25% duty cycle unit rated at 48 VDC, specify C5M-L-267-B-1.

Please see [www.ledex.com](http://www.ledex.com) (click on Stock Products tab) for our list of stock products available through our distributors.

All specifications subject to change without notice.

# Ledex® C Frame Size C8M — DC Operation

Part Number: C8M - XXX - M-36

All catalogue products manufactured after April 1, 2006 are RoHS Compliant

Select from performance chart below

## Specifications

Continuous Duty Cycle	100% at 20°C ambient temperature
Intermittent Duty Cycle	See below
Holding Force	9.96 N at 20°C
Coil Insulation	Class "A": 105°C max. temperature standard. Other temperature classes are available
Coil Termination	3/16" QC
Plunger Weight	11.3 g
Total Weight	45.4 g
Dimensions	See page H38

- Well-suited for battery operation.



See the "Battery Operated Solenoids" section for complete information.

## Performance

Maximum Duty Cycle	100%	50%	25%	10%
Maximum ON Time (sec) when pulsed continuously	∞	19	9	3
Maximum ON Time (sec) for single pulse	∞	286	92	27
Watts (@ 20°C)	3.6	7	14	35
Ampere Turns (@ 20°C)	464	657	929	1470

### Coil Data

Part Number	Resistance (@20°C)	Ref # Turns	VDC (Nom)	VDC (Nom)	VDC (Nom)	VDC (Nom)
C8M-276-M-36	2.56	404	3.0	4.2	5.9	9.3
C8M-274-M-36	23.2	1252	9.0	12.7	18.0	28.5
C8M-273-M-36	9.30	752	6	8.5	12	19
C8M-272-M-36	37.12	1581	12	17	24	38
C8M-271-M-36	150.73	2736	24	34	48	76
C8M-270-M-36	621.54	5544	48	68	96	152
C8M-269-M-36	3824	15035	120	164	231	366

### NOTES:

- All data is typical.
- Force testing is done with the solenoid in the horizontal position.
- All data reflects operation with no heatsink.
- Magnetic latching versions available. Pull versions standard; push versions available.
- Other coil terminations available.
- All specifications subject to change without notice.

## Typical Force @ 20°C

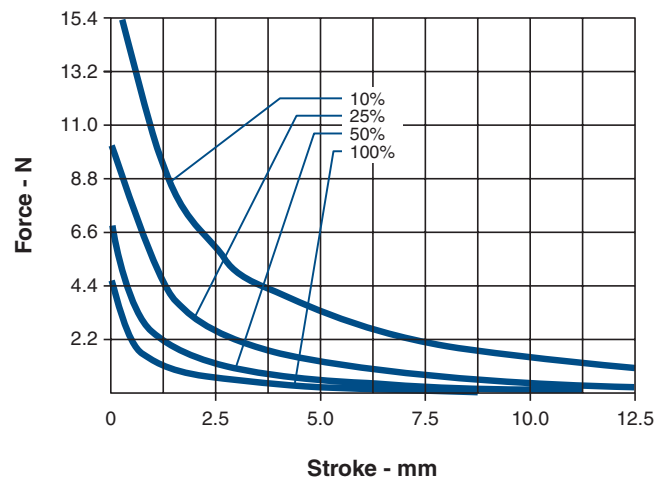

## How to Order

Select the part number from the table provided. (For example, to order a 25% duty cycle unit rated at 48 VDC, specify C8M-271-M-36.

Please see [www.ledex.com](http://www.ledex.com) (click on Stock Products tab) for our list of stock products available through our distributors.

LINEAR Open Frame

Force values for reference only.

All specifications subject to change without notice.

# Ledex® C Frame Size C9M — DC Operation

Part Number: C9M - **XXX** - A-3

All catalogue products manufactured after April 1, 2006 are RoHS Compliant

Select from performance chart below

## Specifications

Continuous Duty Cycle	100% at 20°C ambient temperature
Intermittent Duty Cycle	See below
Holding Force	19.6 N at 20°C
Coil Insulation	Class "A": 105°C max. temperature standard. Other temperature classes are available
Coil Termination	Leadwires
Plunger Weight	21.8 g
Total Weight	128.7 g
Dimensions	See page H38

## Performance

Maximum Duty Cycle	100%	50%	25%	10%
Maximum ON Time (sec) when pulsed continuously	∞	38	17	4
Maximum ON Time (sec) for single pulse	∞	497	160	42
Watts (@ 20°C)	7	14	28	70
Ampere Turns (@ 20°C)	721	1022	1444	2286

### Coil Data

Part Number	Resistance (@20°C)	Ref # Turns	VDC (Nom)	VDC (Nom)	VDC (Nom)	VDC (Nom)
C9M-273-A-3	5.05	648	6	8.5	12	19
C9M-272-A-3	19.88	1275	12	17	24	38
C9M-271-A-3	78.41	2502	24	34	48	76
C9M-270-A-3	338.48	4641	48	68	96	152
C9M-269-A-3	2081	11187	120	170	240	381

### NOTES:

- All data is typical.
- Force testing is done with the solenoid in the horizontal position.
- All data reflects operation with no heatsink.
- Magnetic latching versions available. Pull versions standard; push versions available.
- Other coil terminations available.
- All specifications subject to change without notice.

## Typical Force @ 20°C

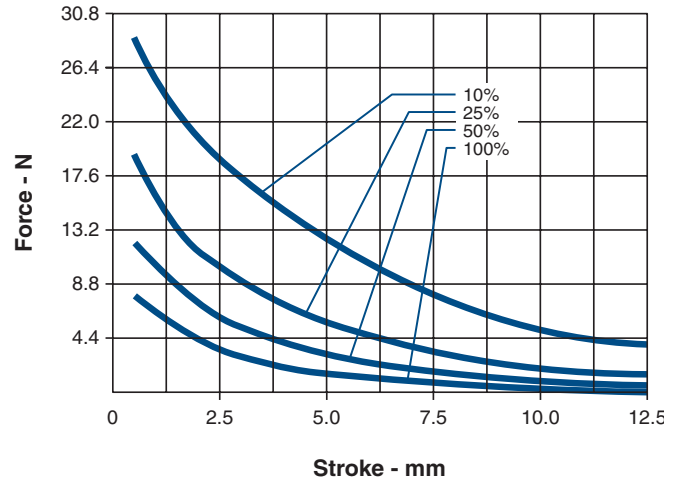

## How to Order

Select the part number from the table provided. (For example, to order a 25% duty cycle unit rated at 48 VDC, specify C9M-271-A-3.

Please see [www.ledex.com](http://www.ledex.com) (click on Stock Products tab) for our list of stock products available through our distributors.

# Ledex® C Frame Size C15M — DC Operation

Part Number: C15M - **XXX** - A- 3

All catalogue products manufactured after April 1, 2006 are RoHS Compliant

Select from performance chart below

## Specifications

Continuous Duty Cycle	At 20°C ambient temperature
Intermittent Duty Cycle	See below
Holding Force	11.1 N at 20°C
Coil Insulation	Class "A": 105°C max. temperature, standard
Coil Termination	Lead wires
Plunger Weight	14.2 g
Total Weight	70.9 g
Dimensions	See page H39

- Well-suited for battery operation.



See the "Battery Operated Solenoids" section for complete information.

## Performance

Maximum Duty Cycle	100%	50%	25%	10%
Maximum ON Time (sec) when pulsed continuously	∞	28	11	4
Maximum ON Time (sec) for single pulse	∞	217	72	24
Watts (@ 20°C)	4.5	9	18	45
Ampere Turns (@ 20°C)	617	870	1229	1947

Part Number	Resistance (@20°C)	Ref # Turns	VDC	VDC	VDC	VDC
			(Nom)	(Nom)	(Nom)	(Nom)
C15M-273-A-3	7.77	855	6	8.5	12	19
C15M-272-A-3	22.4	1749	12	17	24	38
C15M-271-A-3	123.02	3330	24	33	48	74
C15M-270-A-3	514	5985	48	68	96	152
C15M-269-A-3	3106	14690	120	170	240	381

## NOTES:

- All data is typical.
- Force testing is done with the solenoid in the horizontal position.
- All data reflects operation with no heatsink.
- Magnetic latching versions available. Pull versions standard; push versions available.
- Other coil terminations available.
- All specifications subject to change without notice.

## Typical Force @ 20°C

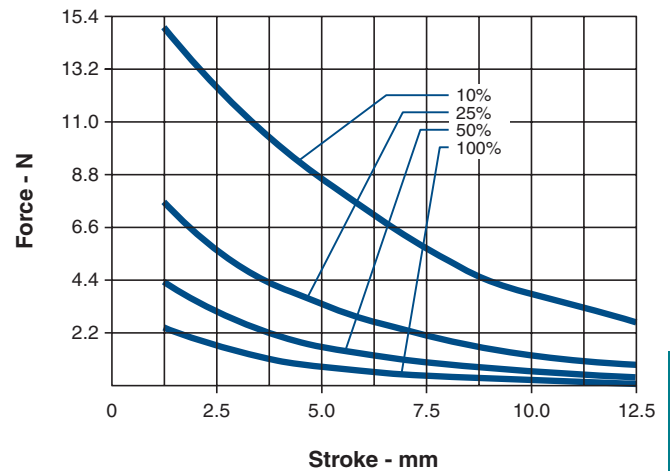

## How to Order

Select the part number from the table provided. (For example, to order a 25% duty cycle unit rated at 48 VDC, specify C15M-271-A-3.

Please see [www.ledex.com](http://www.ledex.com) (click on Stock Products tab) for our list of stock products available through our distributors.

LINEAR Open Frame

# Ledex® C Frame Size C26M — DC Operation

Part Number: C26M - **XXX** - M- 36

All catalogue products manufactured after April 1, 2006 are RoHS Compliant

Select from performance chart below

## Specifications

Continuous Duty Cycle	100% at 20°C ambient temperature
Intermittent Duty Cycle	See below
Holding Force	12.2 N at 20°C
Coil Insulation	Class "A": 105°C max. temperature standard. Other temperature classes are available
Coil Termination	3/16" QC
Plunger Weight	14.2 g
Total Weight	87.9 g
Dimensions	See page H39

## Performance

Maximum Duty Cycle	100%	50%	25%	10%
Maximum ON Time (sec) when pulsed continuously	∞	31	14	5
Maximum ON Time (sec) for single pulse	∞	554	189	56
Watts (@ 20°C)	7	14	28	70
Ampere Turns (@ 20°C)	963	1364	1926	3050

### Coil Data

Part Number	Resistance (@20°C)	Ref # Turns	VDC (Nom)	VDC (Nom)	VDC (Nom)	VDC (Nom)
C26M-273-M-36	5.45	874	6	8.5	12	19
C26M-272-M-36	20.75	1672	12	17	24	38
C26M-271-M-36	81.13	3255	24	34	48	76
C26M-270-M-36	311.42	6235	48	68	96	152
C26M-269-M-36	2092	14117	120	171	240	382

### NOTES:

- All data is typical.
- Force testing is done with the solenoid in the horizontal position.
- All data reflects operation with no heatsink.
- Magnetic latching versions available. Pull versions standard; push versions available.
- Other coil terminations available.
- All specifications subject to change without notice.

## Typical Force @ 20°C

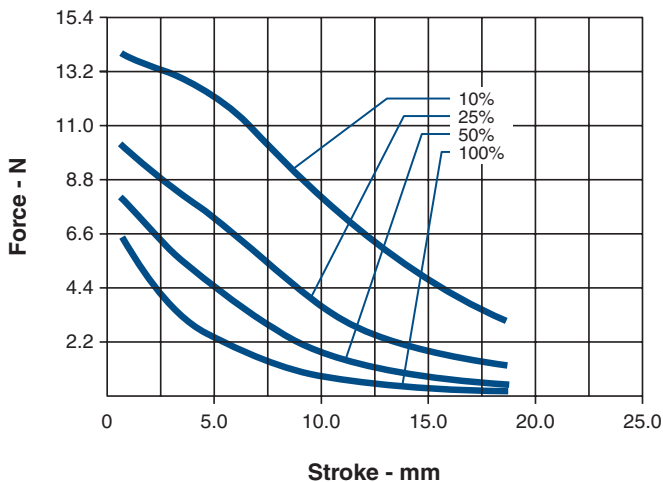

## How to Order

Select the part number from the table provided. (For example, to order a 25% duty cycle unit rated at 48 VDC, specify C26M-271-M-36.

Please see [www.ledex.com](http://www.ledex.com) (click on Stock Products tab) for our list of stock products available through our distributors.

# Ledex® C Frame Size C33M — DC Operation

Part Number: C33M - **XXX** - M-33

All catalogue products manufactured after April 1, 2006 are RoHS Compliant

Select from performance chart below

## Specifications

Continuous Duty Cycle	At 20°C ambient temperature.
Intermittent Duty Cycle	See below
Holding Force	18.9 N at 20°C
Coil Insulation	Class "A": 105°C max. temperature standard. Other temperature classes are available
Coil Termination	1/4" QC
Plunger Weight	14.2 g
Total Weight	110.6 g
Dimensions	See page H40

## Performance

Maximum Duty Cycle	100%	50%	25%	10%
Maximum ON Time (sec) when pulsed continuously	∞	38	16	6
Maximum ON Time (sec) for single pulse	∞	379	145	38
Watts (@ 20°C)	7	14	28	70
Ampere Turns (@ 20°C)	828	1172	1656	2622

### Coil Data

Part Number (Nom)	Resistance (@20°C)	Ref # Turns	VDC (Nom)	VDC (Nom)	VDC (Nom)	VDC (Nom)
C33M-273-M-33	5.38	747	6	8.5	12	19
C33M-272-M-33	21.00	1458	12	17	24	38
C33M-271-M-33	81.20	2812	24	34	48	76
C33M-270-M-33	329.25	5616	48	68	96	152
C33M-269-M-33	2043	13623	120	169	240	378

### NOTES:

- All data is typical.
- Force testing is done with the solenoid in the horizontal position.
- All data reflects operation with no heatsink.
- Magnetic latching versions available. Pull versions standard; push versions available.
- Other coil terminations available.
- All specifications subject to change without notice.

## Typical Force @ 20°C

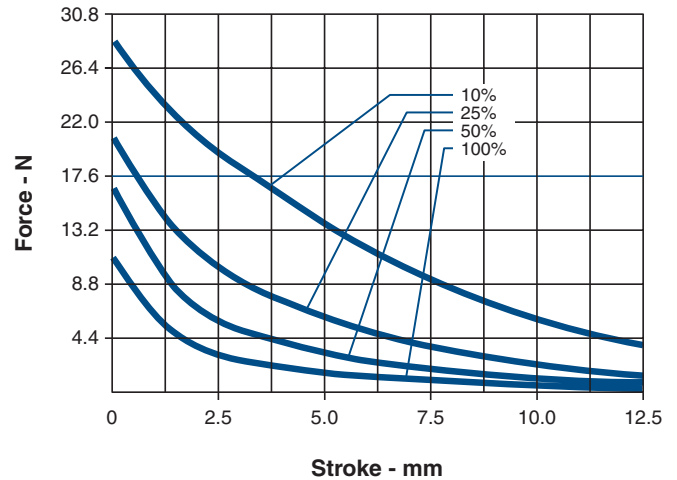

## How to Order

Select the part number from the table provided. (For example, to order a 25% duty cycle unit rated at 48 VDC, specify C33M-271-M-33.

Please see [www.ledex.com](http://www.ledex.com) (click on Stock Products tab) for our list of stock products available through our distributors.

LINEAR Open Frame

# Ledex® C Frame Size C34M — DC Operation

Part Number: C34M - **XXX** - M-33

All catalogue products manufactured after April 1, 2006 are RoHS Compliant

Select from performance chart below

## Specifications

Continuous Duty Cycle	At 20°C ambient temperature
Intermittent Duty Cycle	See below
Holding Force	26.7 N at 20°C
Coil Insulation	Class "A": 105°C max. temperature standard. Other temperature classes are available
Coil Termination	1/4" QC
Plunger Weight	34 g
Total Weight	192.8 g
Dimensions	See page H40

## Performance

Maximum Duty Cycle	100%	50%	25%	10%
Maximum ON Time (sec) when pulsed continuously	∞	45	20	7
Maximum ON Time (sec) for single pulse	∞	453	160	47
Watts (@ 20°C)	10	20	40	100
Ampere Turns (@ 20°C)	1188	1684	2377	3763

### Coil Data

Part Number	Resistance (@20°C)	Ref # Turns	VDC (Nom)	VDC (Nom)	VDC (Nom)	VDC (Nom)
C34M-273-M-33	3.64	632	6	8.5	12	19
C34M-272-M-33	14.47	1224	12	17	24	38
C34M-271-M-33	57.65	2424	24	34	48	76
C34M-270-M-33	229.17	4777	48	68	96	152
C34M-269-M-33	1428	11907	120	169	240	378

### NOTES:

- All data is typical.
- Force testing is done with the solenoid in the horizontal position.
- All data reflects operation with no heatsink.
- Magnetic latching versions available. Pull versions standard; push versions available.
- Other coil terminations available.
- All specifications subject to change without notice.

## Typical Force @ 20°C

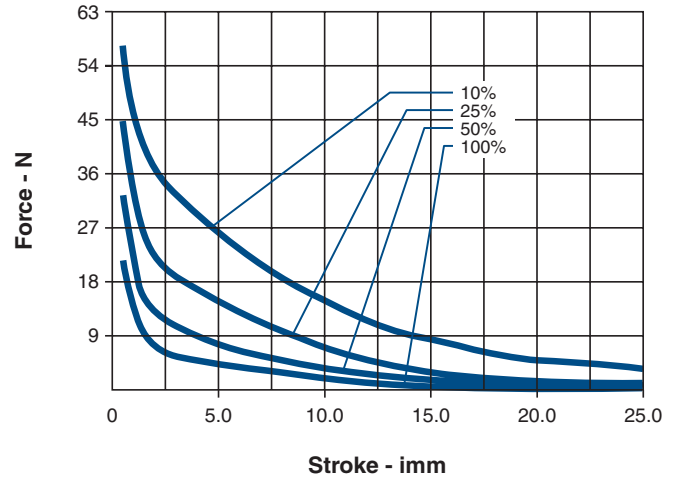

## How to Order

Select the part number from the table provided. (For example, to order a 25% duty cycle unit rated at 48 VDC, specify C34M-271-M-33.

Please see [www.ledex.com](http://www.ledex.com) (click on Stock Products tab) for our list of stock products available through our distributors.

# Ledex® Box Frame Dimensions

mm

All solenoids are illustrated in energised state

## B4HDM

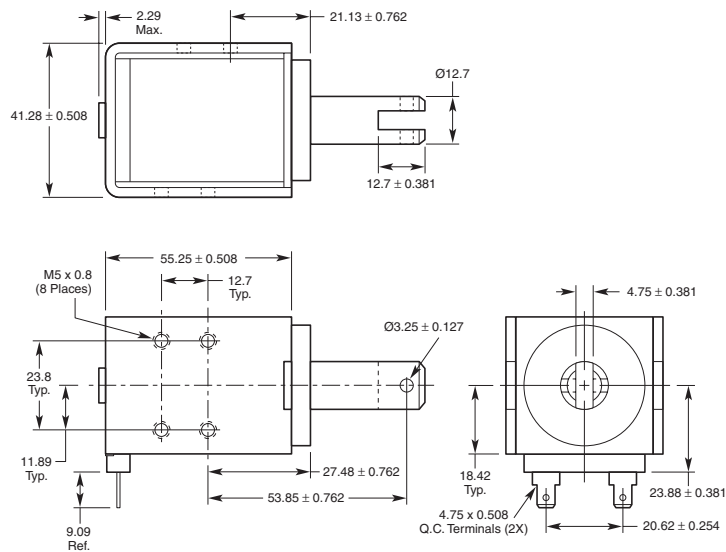

## B11M

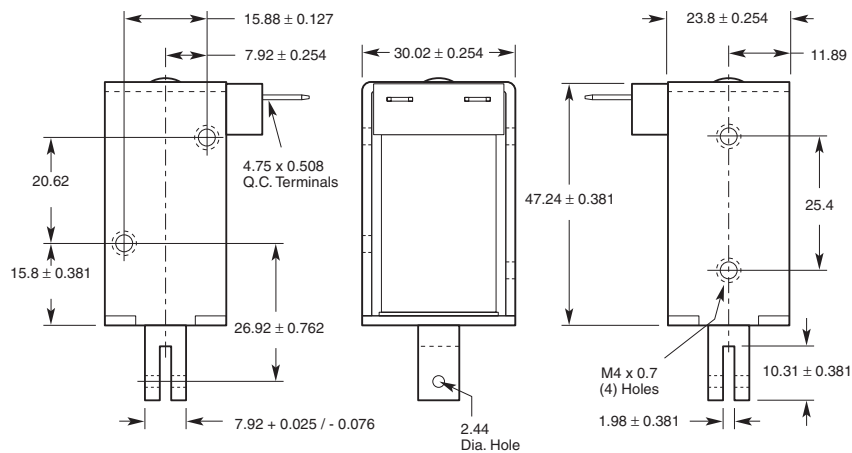

LINEAR Open Frame

All specifications subject to change without notice.

# Ledex® Box Frame Dimensions

mm

All solenoids are illustrated in energised state

## B14M

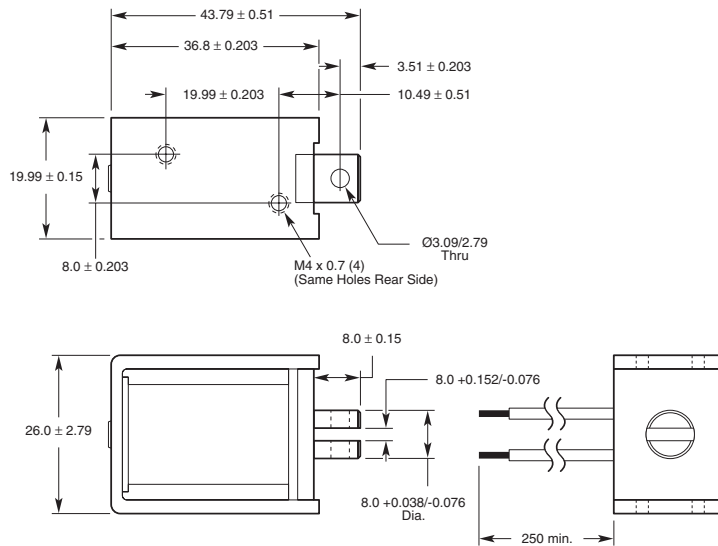

## B14M-L

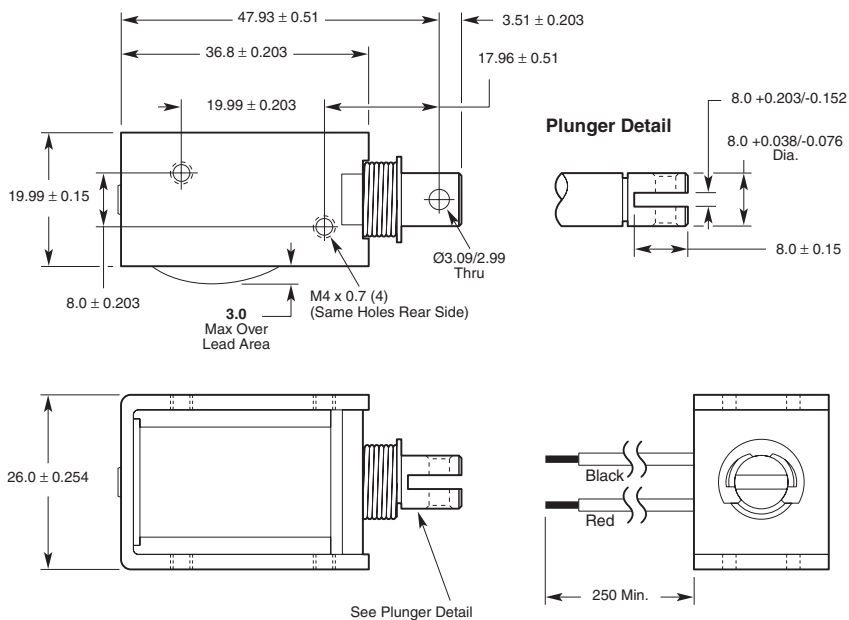

LINEAR Open Frame

All specifications subject to change without notice.

# Ledex® Box Frame Dimensions

mm

All solenoids are illustrated in energised state

## B16M

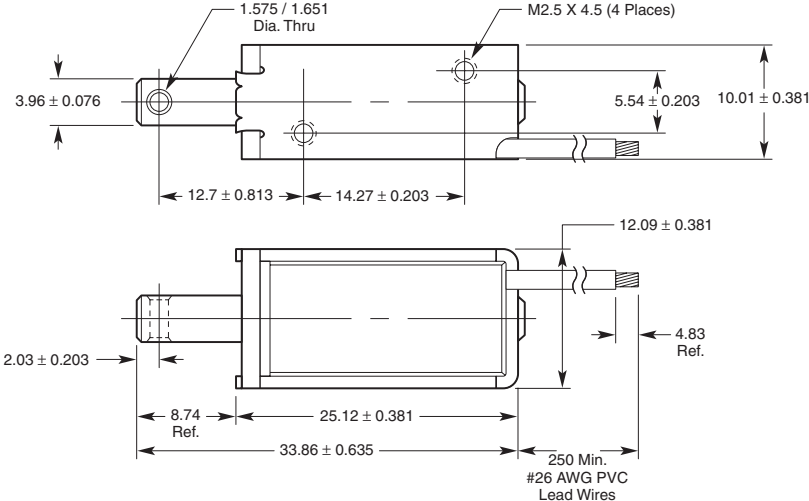

## B16M-L

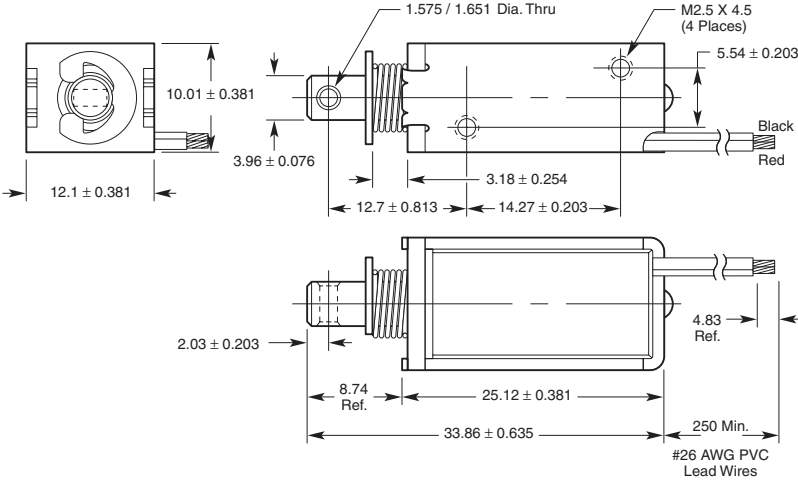

LINEAR Open Frame

All specifications subject to change without notice.

# Ledex® Box Frame Dimensions

mm

All solenoids are illustrated in energised state

## B17M

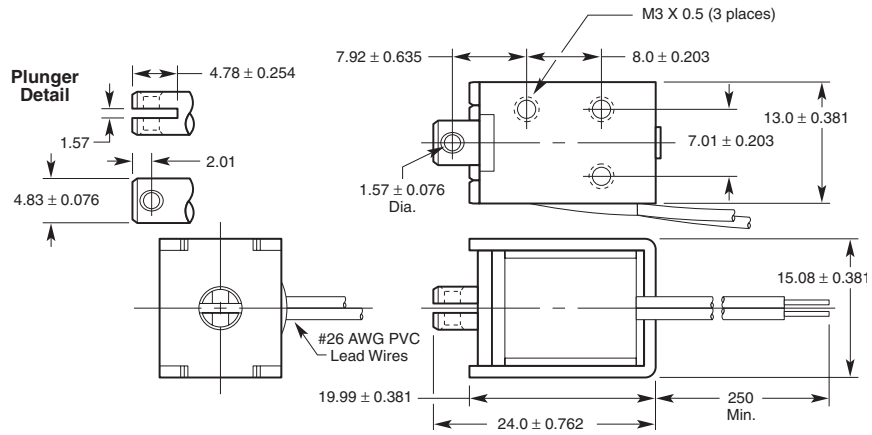

## B17M-L

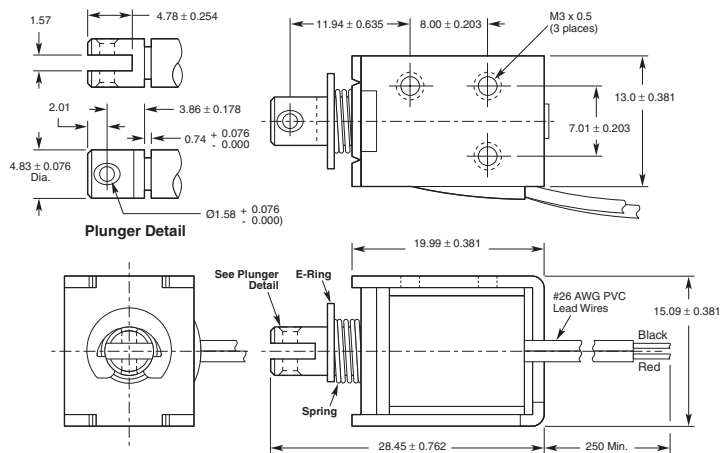

LINEAR Open Frame

All specifications subject to change without notice.

# Ledex<sup>®</sup> Box Frame Dimensions

mm

All solenoids are illustrated in energised state

## B20M

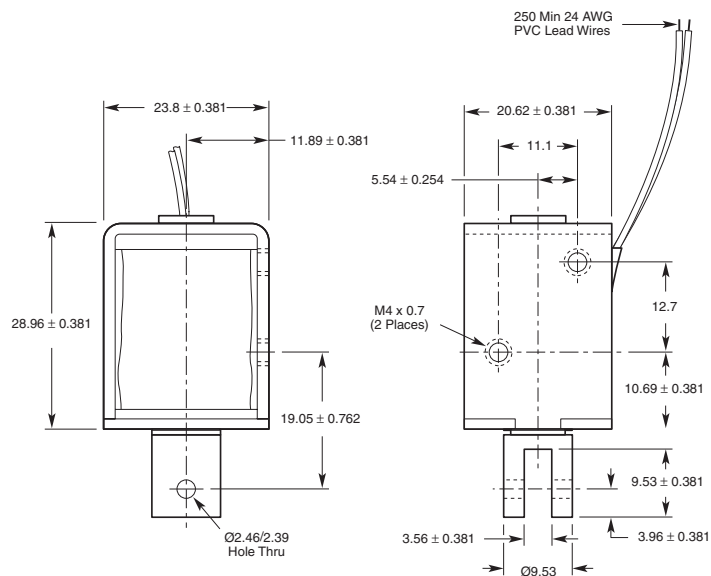

## B21M

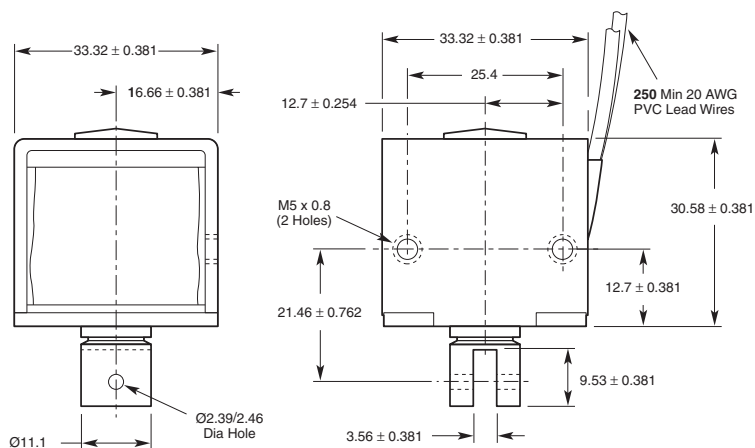

LINEAR Open Frame

All specifications subject to change without notice.

# Ledex® Box Frame Dimensions

mm

All solenoids are illustrated in energised state

## B22M

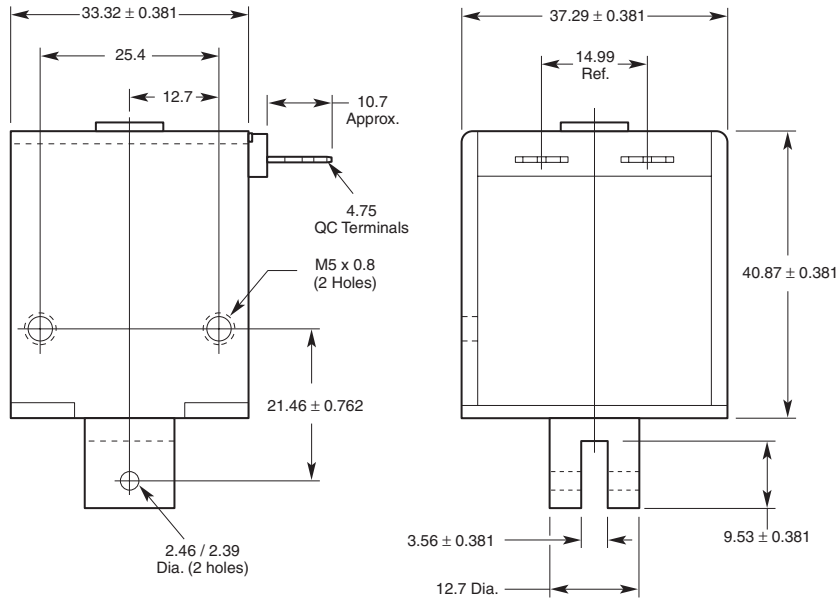

## B22M-L

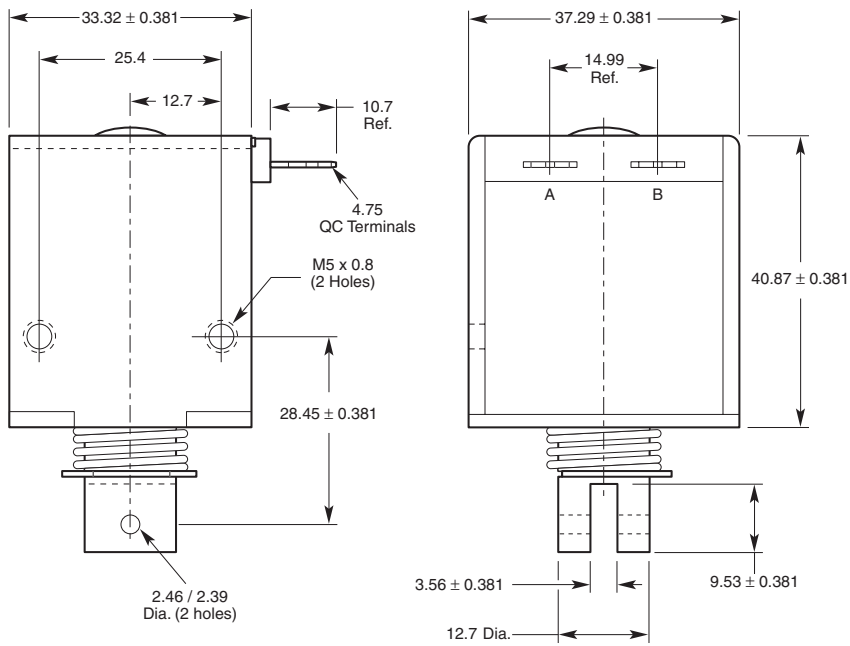

LINEAR Open Frame

All specifications subject to change without notice.

# Ledex<sup>®</sup> Box Frame Dimensions

mm

All solenoids are illustrated in energised state

## B27M

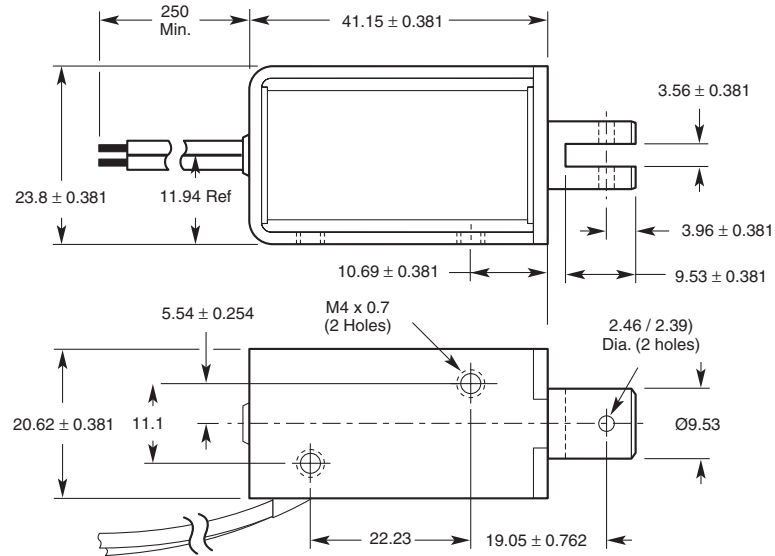

## B41M

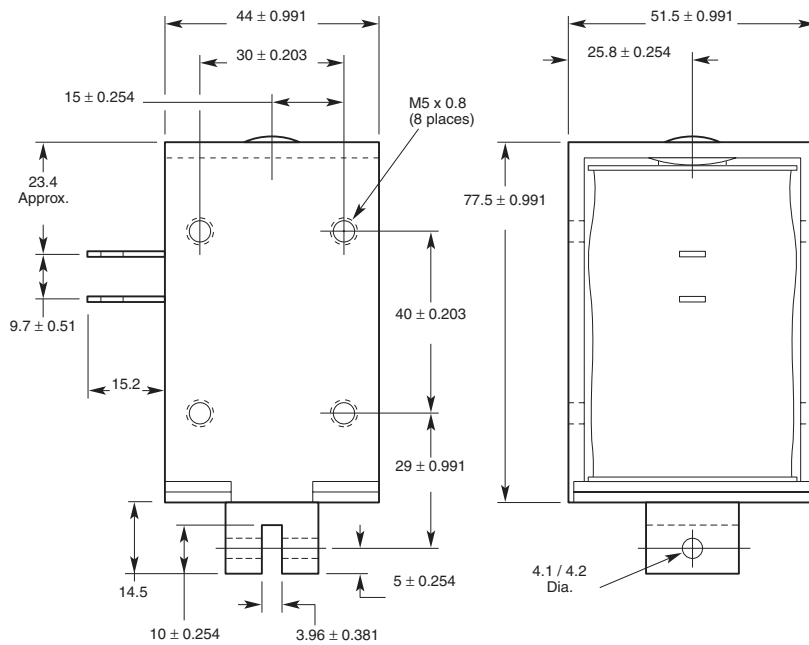

LINEAR Open Frame

All specifications subject to change without notice.

# Ledex® Box Frame Dimensions

mm

All solenoids are illustrated in energised state

B75M

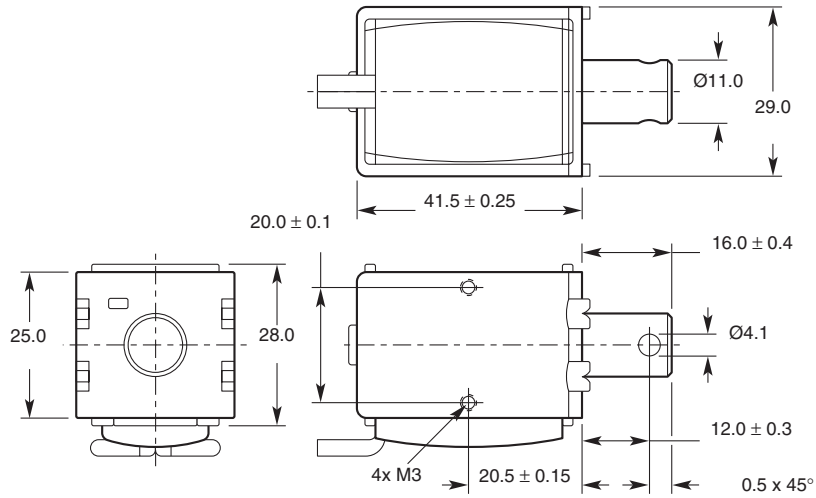

LINEAR Open Frame

All specifications subject to change without notice.

# Ledex® C Frame Dimensions

mm

All solenoids are illustrated in energised state

## C5M

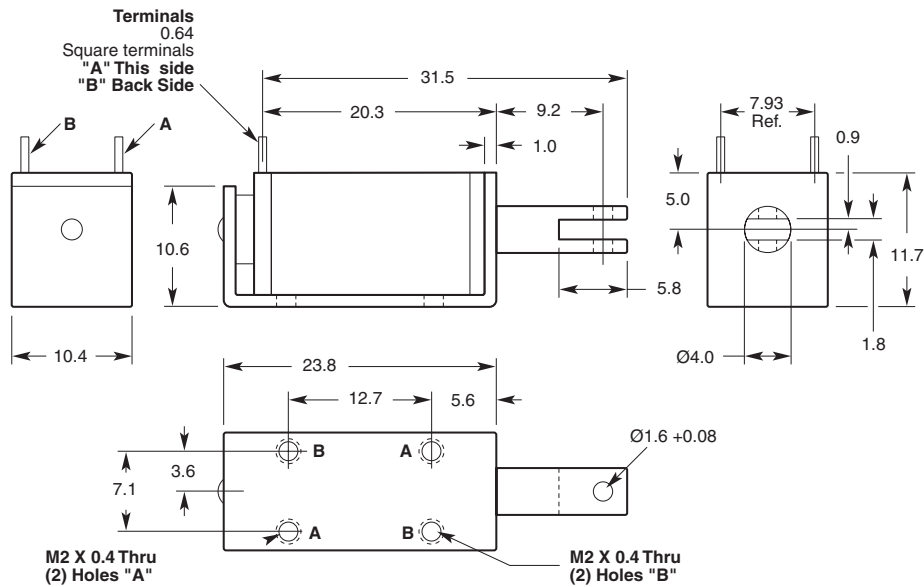

## C5M-L

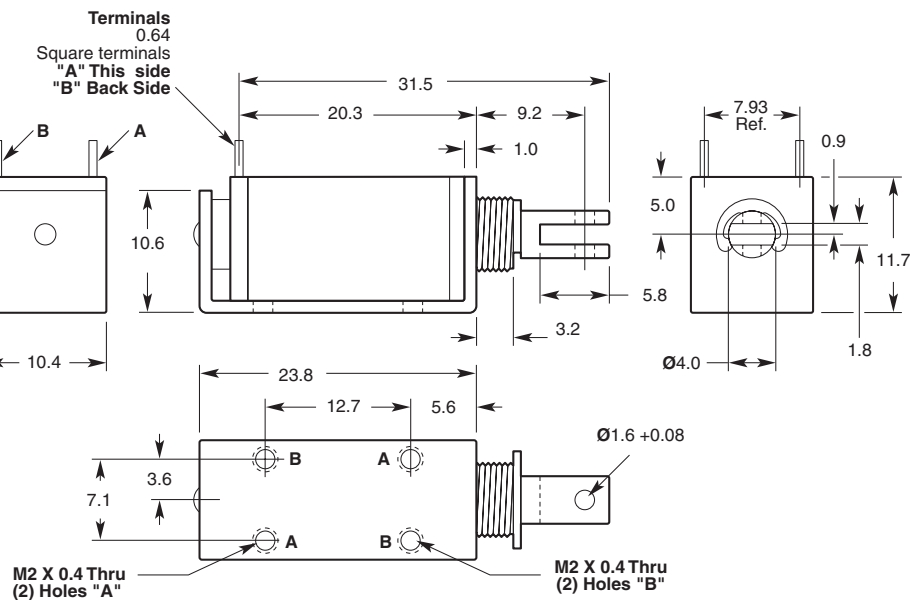

LINEAR Open Frame

All specifications subject to change without notice.

# Ledex® C Frame Dimensions

mm

All solenoids are illustrated in energised state

## C8M

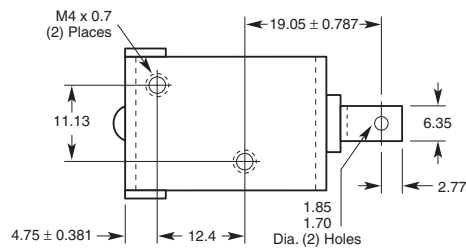
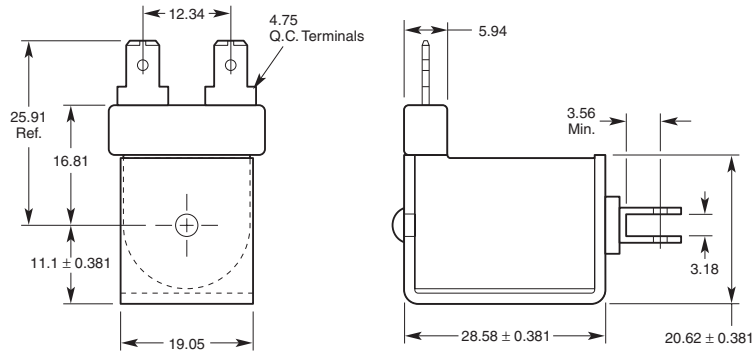

## C9M

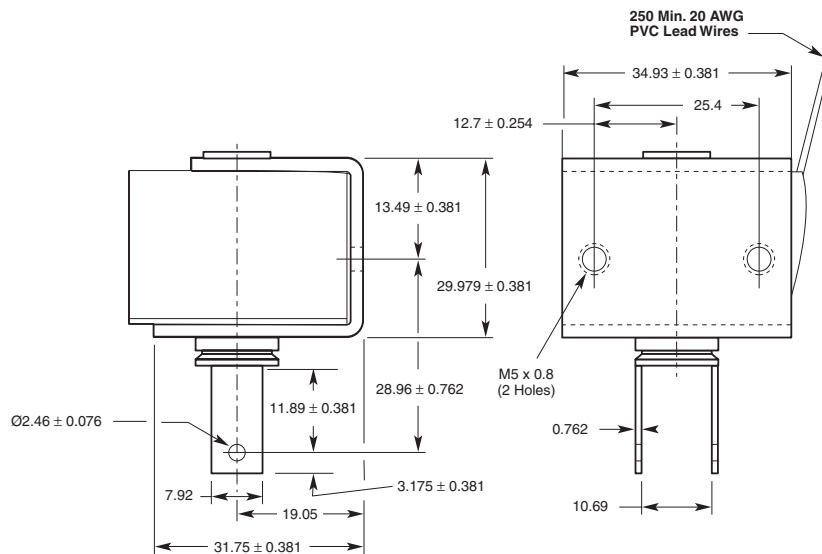

All specifications subject to change without notice.

# Ledex® C Frame Dimensions

mm

All solenoids are illustrated in energised state

## C15M

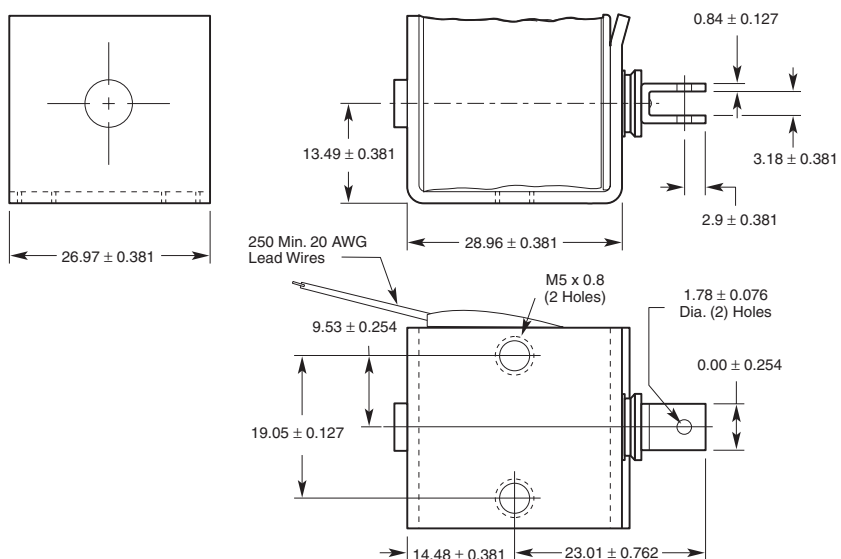

## C26M

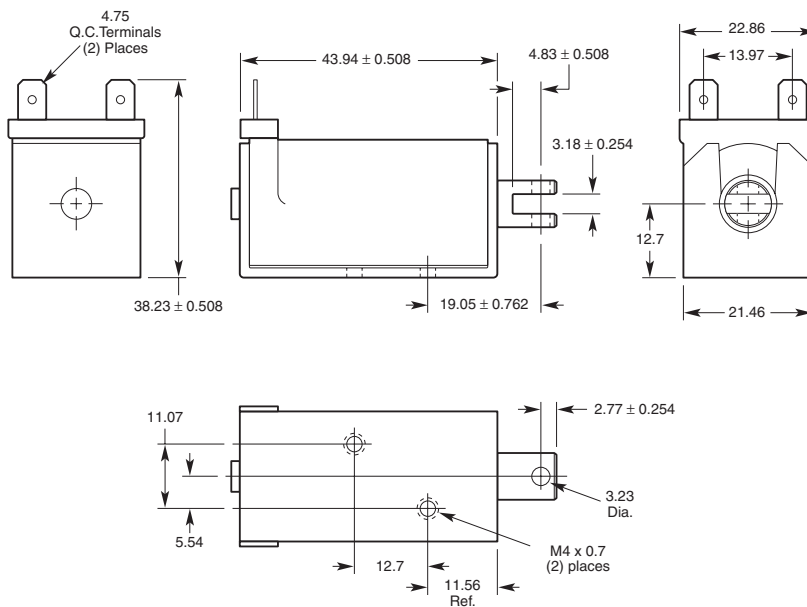

LINEAR Open Frame

All specifications subject to change without notice.

# Ledex® C Frame Dimensions

mm

All solenoids are illustrated in energised state

## C33M

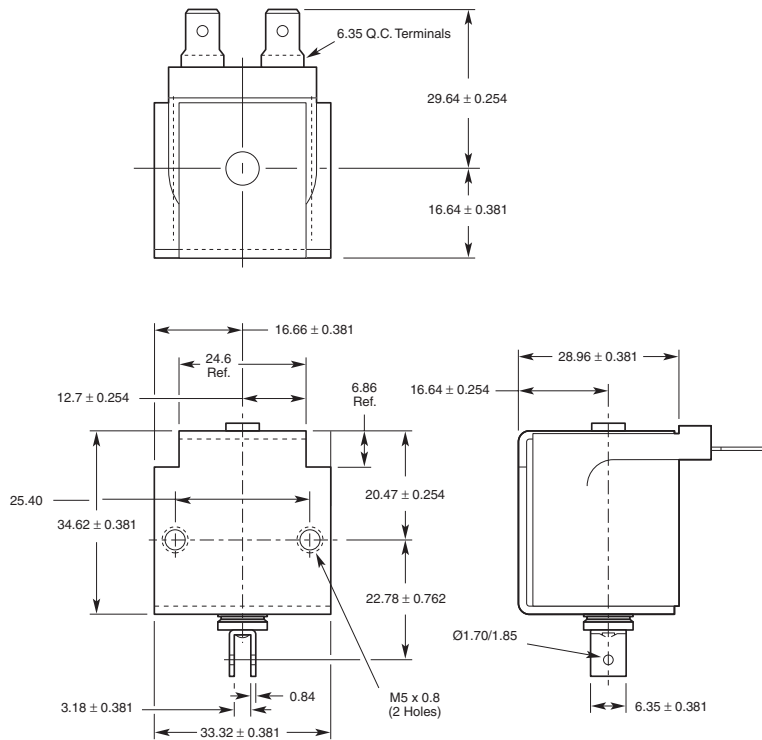

## C34M

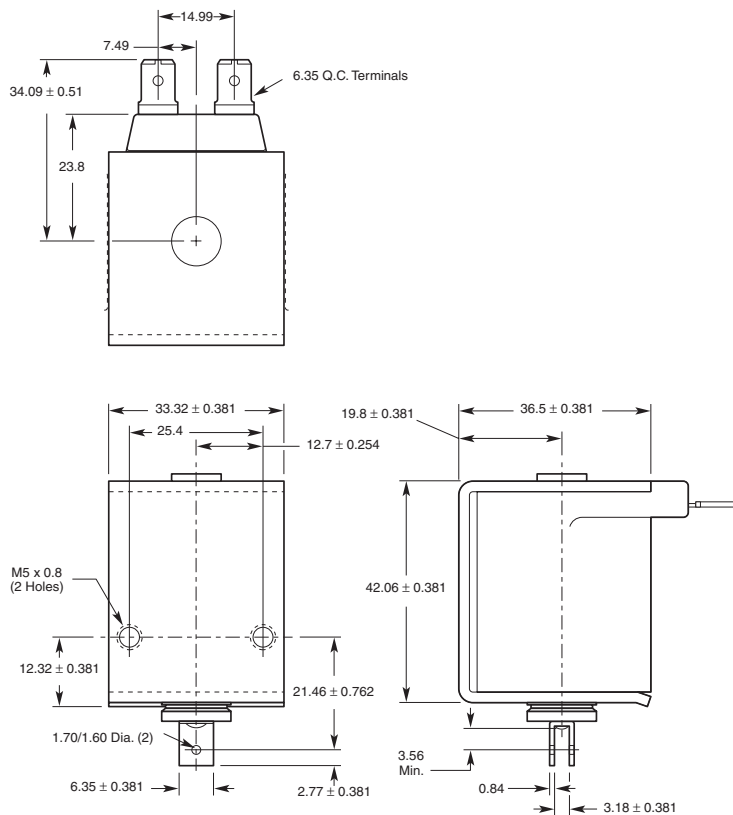

All specifications subject to change without notice.

## Ledex<sup>®</sup> Magnetic Latching Linear Solenoids

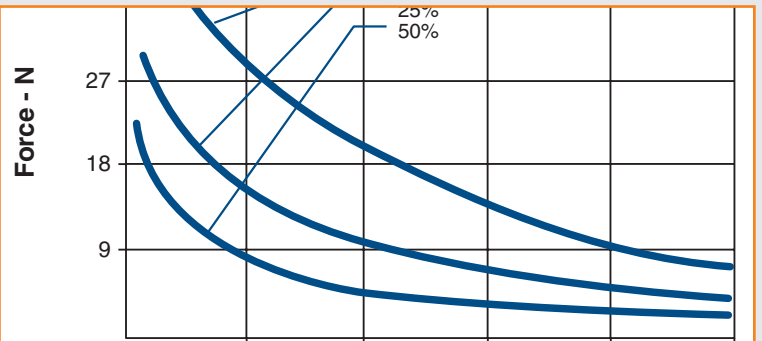

# Ledex® Magnetic Latching Solenoids



- Designed for low duty cycle applications
- Ideal for prolonged energised position
- Well-suited for battery operation
- Tubular and open frame designs available
- Forces to 140 N
- Stroke lengths to 15 mm

All catalogue products manufactured after April 1, 2006 are RoHS Compliant

Magnetic latching solenoids are designed for low duty cycle applications where the solenoid's energised position is needed for an extended period of time.

When power is applied to the solenoid, the plunger moves to its energised position. The plunger latches magnetically in this position and remains there, consuming no power, until a negative electrical pulse is applied to allow the plunger to unlatch.

The reverse voltage applied is dependent on the load attached to the plunger but must be well below the initial energizing value.

While continuous duty, on/off solenoids tend to develop heat, magnetic latching solenoids do not since no power is consumed in the energised state.

Since magnetic latching solenoids are typically used in low duty cycle applications, they are also perfect candidates for battery operation. These products are therefore catalogued as standard as low as 3-6 volts.

Typical applications for magnetic latching solenoids include door closers, locks, latches and security devices. Almost any solenoid type can be developed as a magnetic latching version. We offer open frame and tubular varieties as catalogue standard products.

## Magnetic Latching Designs



### STA® Tubular

In the pull type tubular design, the plunger is pulled into the solenoid coil when the coil is energised. The tubular design offers the most compact package size to force ratio and substantially longer life.



### Box Frame

This solenoid has a 4-sided closed box frame and solid plunger and is, therefore, more electrically efficient than the C Frame solenoid. The closed, box frame also provides improved mechanical strength.

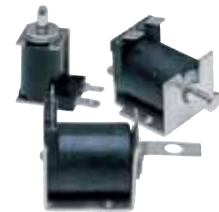

### C Frame

C Frame solenoids consist of a formed C-shaped steel frame and solid plunger. Therefore, these solenoids are less efficient and less costly than their Box Frame counterparts.

# Ledex® Magnetic Latching Solenoids

## Performance Curves

The performance curves in this section serve as guides to determine the solenoid size needed to produce a desired force at a given stroke, duty cycle, and power source. All curves were developed under the following standard test conditions: ambient temperature of 20°C, 65% relative humidity.

## Starting Force

When determining an application's force requirement, apply a 1.5 safety factor. For example: a load requiring 1.0 N of force should utilise a solenoid providing 1.0 x 1.5 or 1.5 N of force.

## Duty Cycle

Magnetic Latching solenoids are rated for low duty cycle applications.

Duty cycle is determined by:  $ON\ time / (ON + OFF\ time)$ .

For example: a solenoid is actuated for 30 seconds, then off for 90 seconds.

$$30\ sec\ ON / (30\ Sec\ ON + 90\ sec\ OFF) = 30/120 = 1/4\ or\ 25\%\ duty\ cycle.$$

Note that maximum ON time for a particular application can be a factor which overrides the duty cycle rating. For example, at 25% duty cycle, the maximum ON time for a given Ledex solenoid is 36 seconds. If, however, the solenoid is operated at a cycle rate which enables the unit to return to ambient temperature between ON cycles, then the maximum ON time is extended somewhat. In the above example, this extended ON time is 44 seconds. Maximum ON time ratings are listed on the individual model specification pages.

## Life

The STA® tubular design offers a life of 25,000,000 actuations. The open frame designs provide 50,000 to 100,000 actuations.

## Power Requirements

Voltage applied to the solenoid must be matched to the coil wire size for proper operation. Solenoids are typically catalogued in coil awgs ranging from #25 up to #38 to accommodate your input power. Refer to the individual model specification pages for coil wire awg recommendations. Many other coil awg sizes are available. Please feel free to contact our application engineering department for availability.

## Options and Modified Designs

Even though many solenoid designs are in stock and available via distribution, our customers often require a product with unique features or performance capabilities. In fact, almost 80% of all solenoids that we make are either modified or custom built to meet our customers' exact application requirements.

So, if you don't find what you're looking for in the catalogue, give us a call to discuss your needs with one of our application engineers.

## Typical Examples of Custom Features

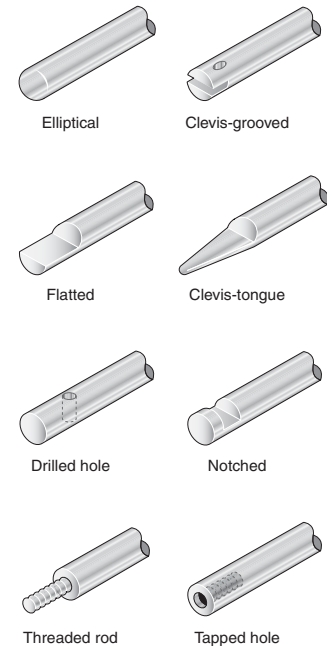

## STA® Tubular Magnetic Latching Selection Overview\*

Size	Solenoid Type	Package Dimension (mm)		Max Stroke (mm)	Nominal Stroke (mm)	Force (N) @ Nominal Stroke and Specified Duty Cycle		
		Dia.	Length			50%	25%	10%
STA 13 x 16 ●	Pull	13.2	13.9	2.5	1.3	1.33	2.22	4.45

## Box Frame and C Frame Magnetic Latching Selection Overview\*

Size	Frame Type	Coil Type <sup>(1)</sup>	Height (mm)	Width (mm)	Length (mm)	Max. Stroke (mm)	Nominal Stroke (mm)	Force (N) @ Nominal Stroke <sup>(2)</sup> and 25% Duty Cycle
B14M-L ●	Box	T	25.9	20.1	36.8	15.2	2.5	8.9
B16M-L ●	Box	T	12.2	9.9	25.1	3.8	1.3	0.7
B17M-L ●	Box	T	15.0	13.0	28.4	4.1	2.0	0.9
B22M-L	Box	OM	37.3	33.3	40.9	8.9	2.5	14.7
C5M-L ●	C	T	11.7	10.4	23.9	5.1	1.3	1.8

<sup>(1)</sup> OM = Overmolded T = Taped

<sup>(2)</sup> With flat face plunger

\* All data is at 20°C coil temperature. Force outputs degrade with elevated temperatures.

● Well-suited for battery operation.

See the "Battery Operated Solenoids" section for complete information.

# STA® Magnetic Latching Pull Tubular — 13 mm Dia. x 16 mm

Part Number: 151094 - X XX

All catalogue products manufactured after April 1, 2006 are RoHS Compliant

Coil AWG Number  
(from performance chart below)

Plunger Configurations and anti-rotation flat on mounting  
 1 Flat Face plunger without anti-rotation flat on mounting  
 2 60° plunger without anti-rotation flat on mounting  
 5 Flat Face plunger with anti-rotation flat on mounting  
 6 60° plunger with anti-rotation flat on mounting

Well-suited for battery operation.



See the "Battery Operated Solenoids" section for complete information.

## Coil Polarity

Latch: A+ B-  
Unlatch: A- B+

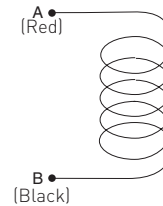

## Performance

	Unlatched Voltage			
	50%	25%	10%	
Maximum Duty Cycle				
Maximum ON Time (sec) when pulsed continuously <sup>1</sup>	n/a	50	5	2
Watts (@ 20°C)	3	6	12	30
Ampere Turns (@ 20°C)	268	379	536	847

### Coil Data

avg (0XX) <sup>2</sup>	Resistance (@20°C)	# Turns <sup>3</sup>	Unlatched VDC	VDC (Nom)	VDC (Nom)	VDC (Nom)
27	0.48	108	1.2	1.7	2.4	3.8
28	0.67	123	1.5	2.1	2.9	4.6
29	1.33	184	1.9	2.7	4.0	6.1
30	1.80	204	2.4	3.3	4.7	7.5
31	3.33	290	3.1	4.4	6.2	9.7
32	4.57	325	3.8	5.3	7.5	11.9
33	7.80	432	4.8	6.8	9.7	15.3
34	13.10	567	6.2	8.8	12.4	20.0
35	17.80	630	7.6	11.0	15.0	24.0
36	29.05	808	9.6	14.0	19.0	30.0
37	45.70	1008	12.2	17.0	24.0	38.0

- <sup>1</sup> Continuously pulsed at stated watts and duty cycle  
<sup>2</sup> Other coil awg sizes available — please consult factory  
<sup>3</sup> Reference number of turns

## Specifications

Operation	Pull
Dielectric Strength	500 VRMS
Recommended Minimum Heat Sink	Maximum watts dissipated by solenoid are based on an unrestricted flow of air at 20°C, with solenoid mounted on the equivalent of an aluminium plate measuring 51 mm square by 3.2 thick
Unlatch Voltage	See schematic and coil data
Magnet Hold Force	7.5 oz (with return spring)
Coil Insulation	Class "B"; 130°C max. temperature standard. Other temperature classes are available.
Coil Termination	250 mm PVC lead wires
Plunger Pole Face	60° with return spring (other options available upon request)
Plunger Weight	2.6 g
Spring Force	9.8 N; 1.2 N latched position
Total Weight	14.74 g
Dimensions	See page I 11

## How to Order

Add the plunger configuration, anti-rotation flat number, and the coil awg number to the part number (for example: to order a 60° plunger unit without an anti-rotation flat, rated for 5 VDC at 25% duty cycle, specify 151094-250).

Please see [www.ledex.com](http://www.ledex.com) (click on Stock Products tab) for our list of stock products available through our distributors.

Force values for reference only.

All specifications subject to change without notice.

# STA<sup>®</sup> Magnetic Latching Pull Tubular — 13 mm Dia. x 16 mm

Pull Tubular Solenoid – 13 mm Dia. x 16 mm – 60° Plunger

All catalogue products manufactured after April 1, 2006 are RoHS Compliant

Typical Force @ 20°C (Net, with Spring)

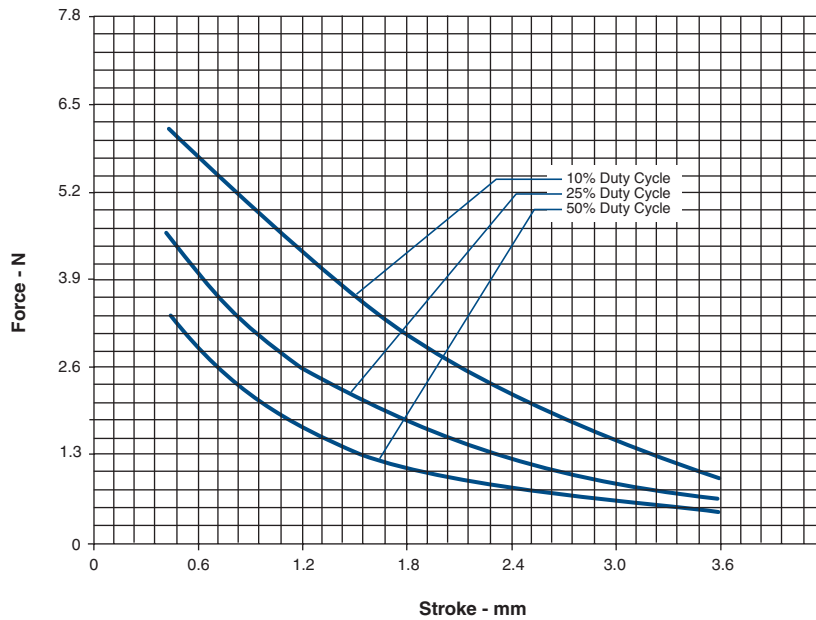

LINEAR Magnet Latch

Force values for reference only.

All specifications subject to change without notice.

# Ledex® Magnetic Latching Box Frame Size B14M-L

Part Number: B14M - L - X XX - B- 4

Coil Selection  
(from performance chart below)

Pole Configuration  
1 Flat Face  
2 50° Conical

All catalogue products manufactured after April 1, 2006 are RoHS Compliant

Well-suited for battery operation.



See the "Battery Operated Solenoids" section for complete information.

## Specifications

Operation	Pull
Dielectric Strength	500 VRMS for one second
Unlatch Voltage	See schematic and coil data below
Magnet Hold Force*	
Flat Face:	9.3 N (with return spring)
50° Conical:	5.6 N (with return spring)
Coil Insulation	Class " B": 130°C max. (standard); other temperature classes available
Coil Termination	250 mm PVC lead wires
Spring Force	0.6 N/mm; 0.8 N latched position
Plunger Pole Face	Flat face with return spring 50° conical with return spring (other options available)
Plunger Weight	14.2 g
Total Weight	95.9 g
Dimensions	See page I 12

\*In no power, latched position

Maximum Duty Cycle	Unlatched			
	Voltage	50%	25%	10%
Maximum ON Time (sec) when pulsed continuously	∞	100	36	7
Maximum ON Time (sec) for single pulse	∞	480	180	45
Watts (@ 20°C)	5.2	10.4	20.8	52.2
Ampere Turns (@ 20°C)	750	1060	1500	2370

Coil Data						
Part Number	Resistance (@20°C)	Ref # Turns	Unlatch VDC	VDC (Nom)	VDC (Nom)	VDC (Nom)
B14M-L-X58-B-4	1.93	421	3	4	6	10
B14M-L-X55-B-4	6.90	871	6	8.5	12	19
B14M-L-X56-B-4	17.40	1228	9	13	18	29
B14M-L-X54-B-4	28.60	1791	12	17	24	38
B14M-L-X53-B-4	110.00	3450	24	34	48	76

## Coil Polarity

Latch: A+ B-  
Unlatch: A- B+

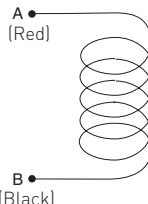

## NOTES:

- All data is typical.
- Force testing is done with the solenoid in the horizontal position.
- All data reflects operation with no heatsink.
- Other coil terminations available.
- All specifications subject to change without notice.

Force values for reference only.

## Typical Force @ 20°C – Flat Face Armature (net with spring)

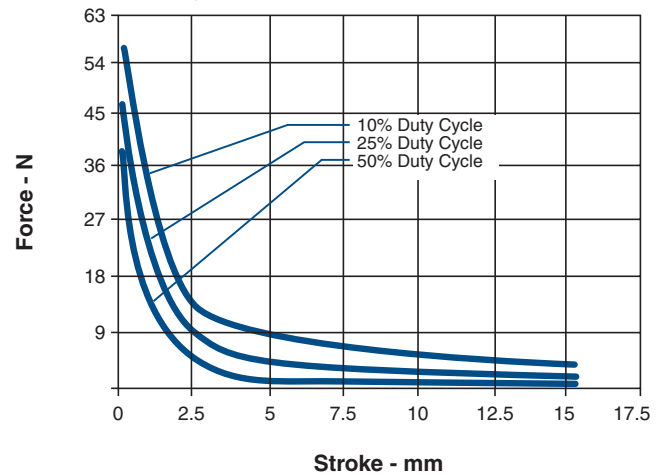

## Typical Force @ 20°C – 50° Conical Armature (net with spring)

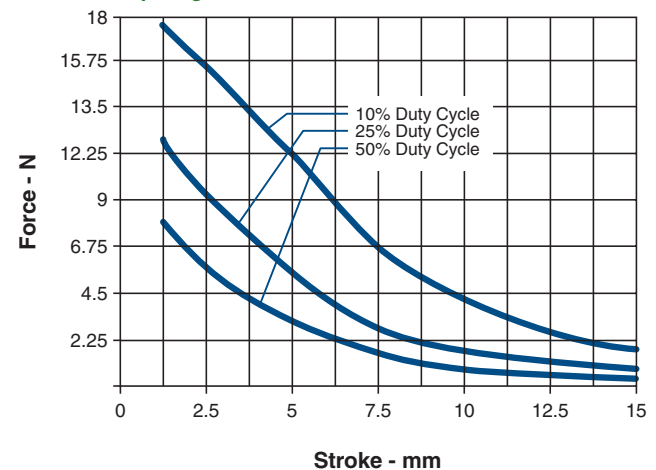

## How to Order

Select the part number from the table provided. (For example, to order a 25% duty cycle unit rated at 48 VDC with a 50° Conical Armature, specify B14M-L-253-B-4.

Please see [www.ledex.com](http://www.ledex.com) (click on Stock Products tab) for our list of stock products available through our distributors.

All specifications subject to change without notice.

# Ledex<sup>®</sup> Magnetic Latching Box Frame Size B16M-L

Part Number: B16M - L - X XX - B- 3

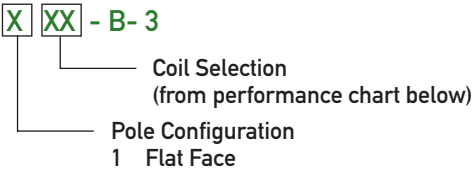

All catalogue products manufactured after April 1, 2006 are RoHS Compliant

Well-suited for battery operation.

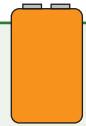

See the "Battery Operated Solenoids" section for complete information.

## Specifications

Operation	Pull
Dielectric Strength	500 VRMS for one second
Unlatch Voltage	See schematic and coil data below
Magnet Hold Force*	1.8 N (with return spring)
Coil Insulation	Class " B": 130°C max. (standard); other temperature classes available
Coil Termination	250 mm PVC lead wires
Spring Force	0.2 N/mm; 0.3 N latched position
Plunger Pole Face	Flat face (other options available)
Plunger Weight	2.46 g
Total Weight	10.12 g
Dimensions	See page I 12

\*In no power, latched position.

## Performance

	Unlatched			
	Voltage	50%	25%	10%
Maximum Duty Cycle	n/a	253	78	19
Maximum ON Time (sec)	n/a	253	78	19
Watts (@ 20°C)	1.43	2.86	5.72	14.3
Ampere Turns (@ 20°C)	270	383	575	855

## Coil Data

Part Number	Resistance (@20°C)	Ref # Turns	Unlatch VDC	VDC (Nom)	VDC (Nom)	VDC (Nom)
B16M-L-158-B-3	6.35	531	3	4.3	6	9.5
B16M-L-155-B-3	22.71	1100	6	8.5	12	19
B16M-L-156-B-3	54.20	1644	9	12.5	17.6	27.8
B16M-L-154-B-3	100.79	2035	12	17	24	38
B16M-L-153-B-3	394.50	3944	24	34	48	76
B16M-L-152-B-3	1630.00	9827	48	68	96	153

## NOTES:

- All data is typical.
- Force testing is done with the solenoid in the horizontal position.
- All data reflects operation with no heatsink.
- Other coil terminations available.
- All specifications subject to change without notice.

## Typical Force @ 20°C (Net, with Spring)

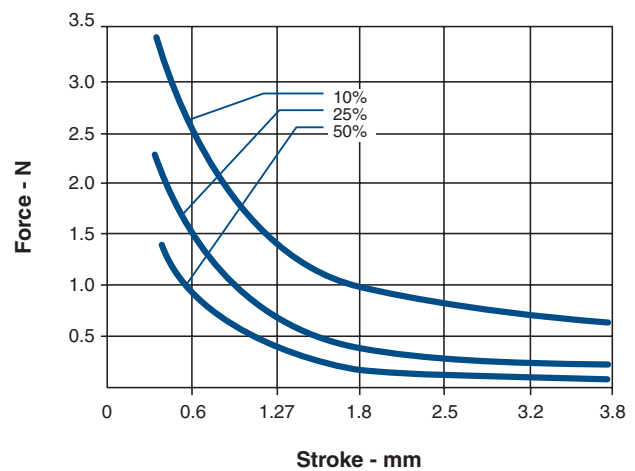

## Coil Polarity

Latch: A+ B-  
Unlatch: A- B+

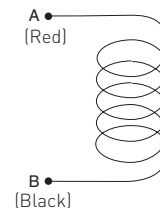

## How to Order

Select the part number from the table provided. (For example, to order a 25% duty cycle unit rated at 48 VDC, specify B16M-L-153-B-3).

Please see [www.ledex.com](http://www.ledex.com) (click on Stock Products tab) for our list of stock products available through our distributors.

LINEAR Magnet Latch

Force values for reference only.

All specifications subject to change without notice.

# Ledex® Magnetic Latching Box Frame Size B17M-L

Part Number: B17M - L - X XX - B-3

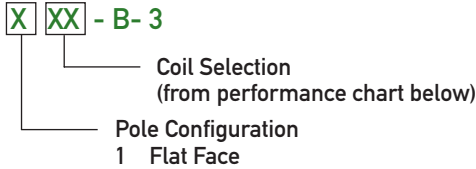

All catalogue products manufactured after April 1, 2006 are RoHS Compliant

Well-suited for battery operation.



See the "Battery Operated Solenoids" section for complete information.

## Specifications

Operation	Pull
Dielectric Strength	500 VRMS for one second
Unlatch Voltage	See schematic and coil data below
Magnet Hold Force*	2.5 N (with return spring)
Coil Insulation	Class "B": 130°C max. (standard); other temperature classes available
Coil Termination	250 mm PVC lead wires
Spring Force	0.4 N/mm; 0.1 N latched position
Plunger Pole Face	Flat face (other options available)
Plunger Weight	2.5 g
Total Weight	19.85 g
Dimensions	See page I 13

\*In no power, latched position.

## Performance

	Unlatched			
	Voltage	50%	25%	10%
Maximum Duty Cycle	n/a	112	36	10.5
Maximum ON Time (sec)	n/a	112	36	10.5
Watts (@ 20°C)	1.6	3.2	6.4	16
Ampere Turns (@ 20°C)	292	414	584	923

### Coil Data

Part Number	Resistance (@20°C)	Ref # Turns	Unlatch VDC	VDC (Nom)	VDC (Nom)	VDC (Nom)
B17M-L-158-B-3	5.40	520	3	4	6	9
B17M-L-155-B-3	21.93	1112	6	8.5	12	19
B17M-L-156-B-3	50.20	1624	9	12	18	28.3
B17M-L-154-B-3	88.95	2219	12	17	24	38
B17M-L-153-B-3	337.00	3687	24	34	48	76
B17M-L-152-B-3	1465.00	9177	48	68	96	153

### NOTES:

- All data is typical.
- Force testing is done with the solenoid in the horizontal position.
- All data reflects operation with no heatsink.
- Other coil terminations available.
- All specifications subject to change without notice.

## Typical Force @ 20°C (Net, with Spring)

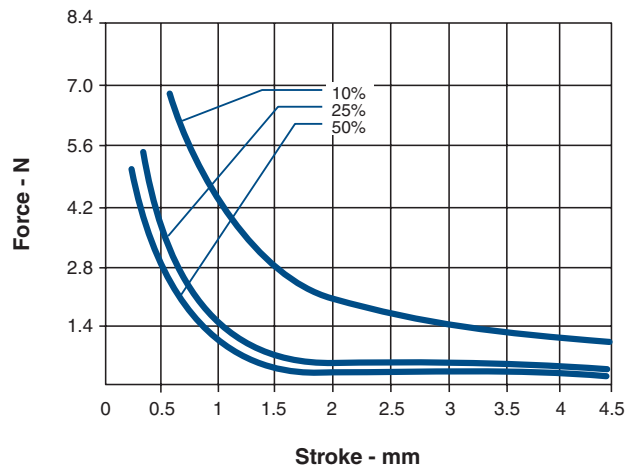

## Coil Polarity

Latch: A+ B-  
Unlatch: A- B+

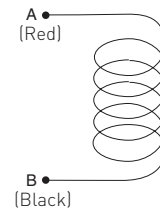

## How to Order

Select the part number from the table provided. (For example, to order a 25% duty cycle unit rated at 48 VDC, specify B17M-L-153-B-3.

Please see [www.ledex.com](http://www.ledex.com) (click on Stock Products tab) for our list of stock products available through our distributors.

Force values for reference only.

All specifications subject to change without notice.

# Ledex® Magnetic Latching Box Frame Size B22M-L

Part Number: B22M - L - X XX - M- 36

Coil Selection  
(from performance chart below)

Pole Configuration  
1 Flat Face  
2 60° Conical

All catalogue products manufactured after April 1, 2006 are RoHS Compliant

## Specifications

Operation	Pull
Dielectric Strength	1500 VRMS for one second
Unlatch Voltage	See schematic and coil data below
Magnet Hold Force*	
Flat Face:	22 N (with return spring)
60° Conical:	4.5 N (with return spring)
Coil Insulation	Class "B": 130°C max. (standard); other temperature classes available
Coil Termination	3/16" QC
Spring Force	0.4 N/mm; 4.8 N latched position
Plunger Pole Face	Flat face with return spring 60° with return spring (other options available)
Plunger Weight	35.2 g
Total Weight	212.8 g
Dimensions	See page I 13

\*In no power, latched position.

## Performance

	Unlatched					
	Voltage	50%	25%	10%		
Maximum Duty Cycle	n/a	485	167	47		
Maximum ON Time (sec)	n/a	485	167	47		
Watts (@ 20°C)	9.9	19.8	39.6	99		
Ampere Turns (@ 20°C)	1046	1482	2093	3314		
Coil Data						
Part Number	Resistance (@20°C)	Ref # Turns	Unlatch VDC	VDC (Nom)	VDC (Nom)	VDC (Nom)
B22M-L-X55-M-36	3.64	635	6	8.5	12	19
B22M-L-X54-M-36	14.55	1300	12	17	24	38
B22M-L-X53-M-36	58.18	2578	24	34	48	76
B22M-L-X52-M-36	232.73	5103	48	68	96	152
B22M-L-X51-M-36	1493.00	12744	120	172	240	385

### NOTES:

- All data is typical.
- Force testing is done with the solenoid in the horizontal position.
- All data reflects operation with no heatsink.
- Other coil terminations available.
- All specifications subject to change without notice.

Force values for reference only.

## Typical Force @ 20°C – 60° Armature (Net, with Spring)

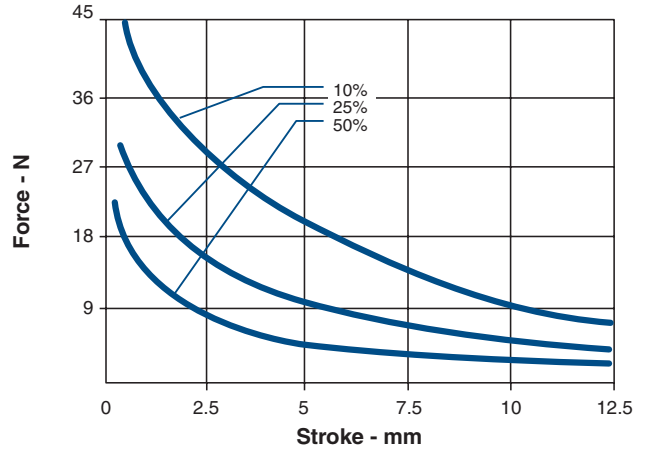

## Typical Force @ 20°C – Flat Face Armature (Net, with Spring)

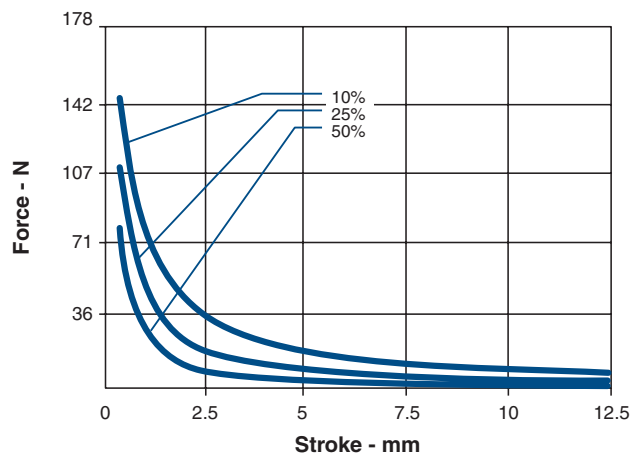

### Coil Polarity

Latch: A+ B-  
Unlatch: A- B+

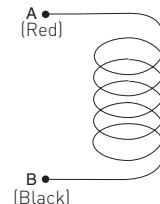

### How to Order

Select the part number from the table provided. (For example, to order a 25% duty cycle flat face unit rated at 48 VDC, specify B22M-L-153-M-36.

Please see [www.ledex.com](http://www.ledex.com) (click on Stock Products tab) for our list of stock products available through our distributors.

All specifications subject to change without notice.

LINEAR Magnet Latch

# Ledex® Magnetic Latching C Frame Size C5M-L

Part Number: C5M - L - **XXX** - B - 1

All catalogue products manufactured after April 1, 2006 are RoHS Compliant

Select from performance chart below

## Specifications

Operation	Pull
Dielectric Strength	500 VRMS for one second
Unlatch Voltage	See schematic and coil data below
Magnet Hold Force*	5.7 N (with return spring)
Coil Insulation	Class "B": 130°C max. temperature standard. Other temperature classes are available
Coil Termination	0.025 inch square pin terminals
Plunger Pole Face	Flat face with return spring (other options available upon request)
Spring Force	0.1 N/mm; 0.7 N latched position
Plunger Weight	2.8 g
Total Weight	11.9 g
Dimensions	See page I 14

\*In no power, latched position.

## Performance

Maximum Duty Cycle	Unlatch Voltage		
	50%	25%	10%
Maximum ON Time (sec)	∞	145	47
Watts (@ 20°C)	3	6	12
Ampere Turns (@ 20°C)	422	564	844

### Coil Data

Part Number	Resistance (@20°C)	Ref # Turns	VDC (Nom)	VDC (Nom)	VDC (Nom)	VDC (Nom)
C5M-L-273-B-1	2.88	406	3	4	6	9
C5M-L-272-B-1	11.52	795	6	8	12	19
C5M-L-271-B-1	25.77	1222	9	12	18	28
C5M-L-270-B-1	48.65	1642	12	17	24	38
C5M-L-269-B-1	72.84	1968	15	21	30	47
C5M-L-268-B-1	152.20	2860	21	30	43	68
C5M-L-267-B-1	191.73	3202	24	34	48	76

### NOTES:

- All data is typical.
- Force testing is done with the solenoid in the horizontal position.
- All data reflects operation with no heatsink.
- Other coil terminations available.
- All specifications subject to change without notice.

Well-suited for battery operation.



See the "Battery Operated Solenoids" section for complete information.

## Force (Net, With Spring)

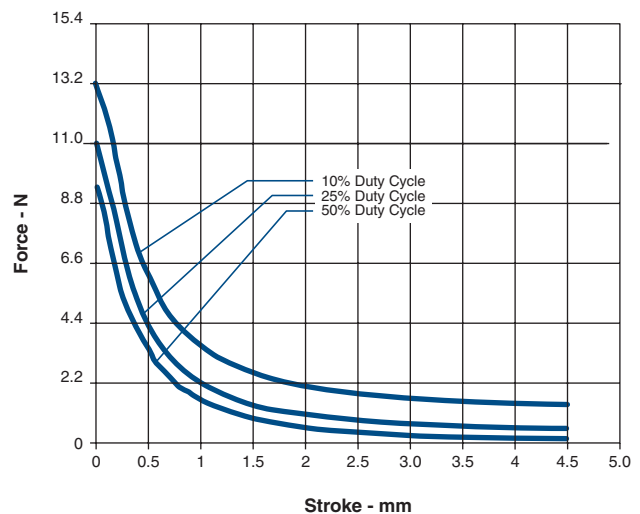

## Coil Polarity

Latch: A+ B-  
Unlatch: A- B+

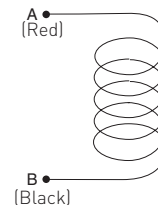

## How to Order

Select the part number from the table provided. (For example, to order a 25% duty cycle unit rated at 48 VDC, specify C5M-L-267-B-1.

Please see [www.ledex.com](http://www.ledex.com) (click on Stock Products tab) for our list of stock products available through our distributors.

Force values for reference only.

All specifications subject to change without notice.

# STA<sup>®</sup> Tubular Magnetic Latching Dimensions

mm

## STA<sup>®</sup> Series Magnetic Latching Pull — 13 mm Dia. x 16 mm

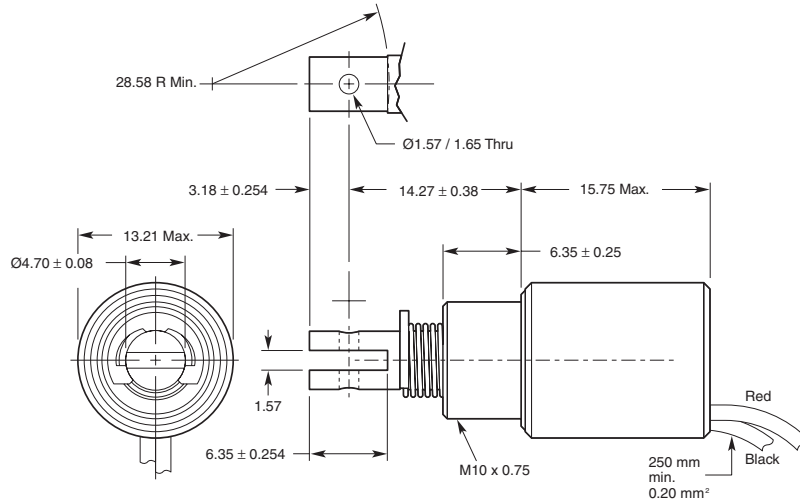

All solenoids are illustrated in energised state

All specifications subject to change without notice.



# Ledex® Box Frame Magnetic Latching Dimensions

mm

## B17M-L

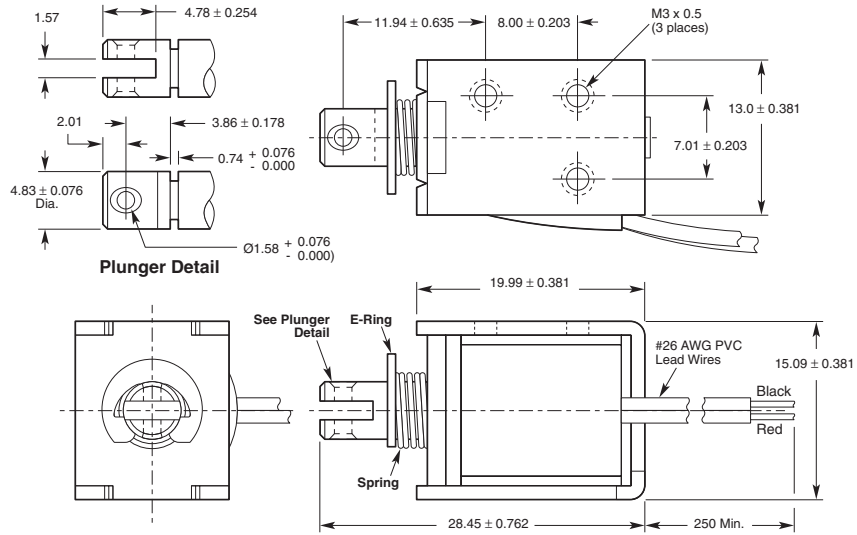

## B22M-L

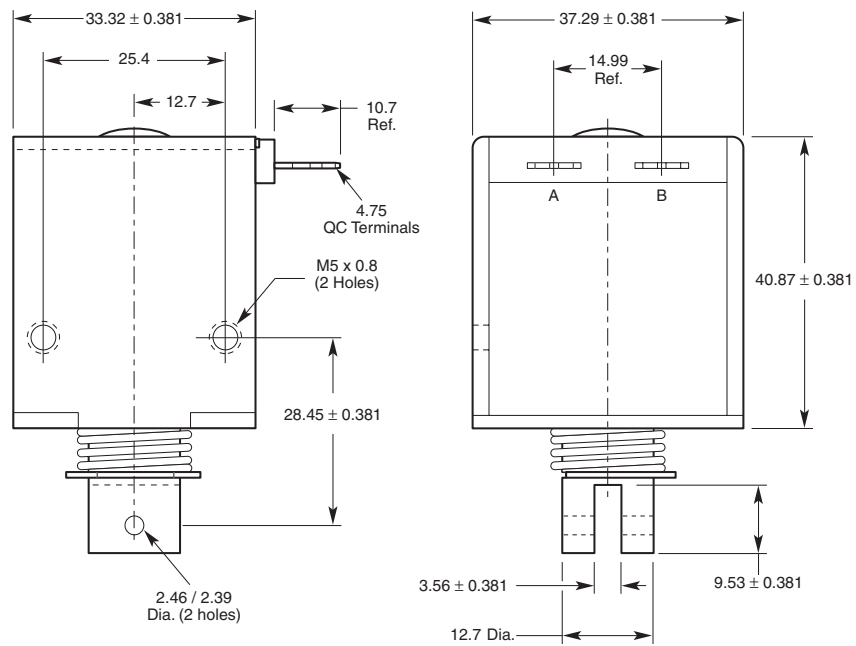

LINEAR Magnet Latch

All solenoids are illustrated in energised state

All specifications subject to change without notice.

# Ledex® C Frame Dimensions

mm

C5M-L

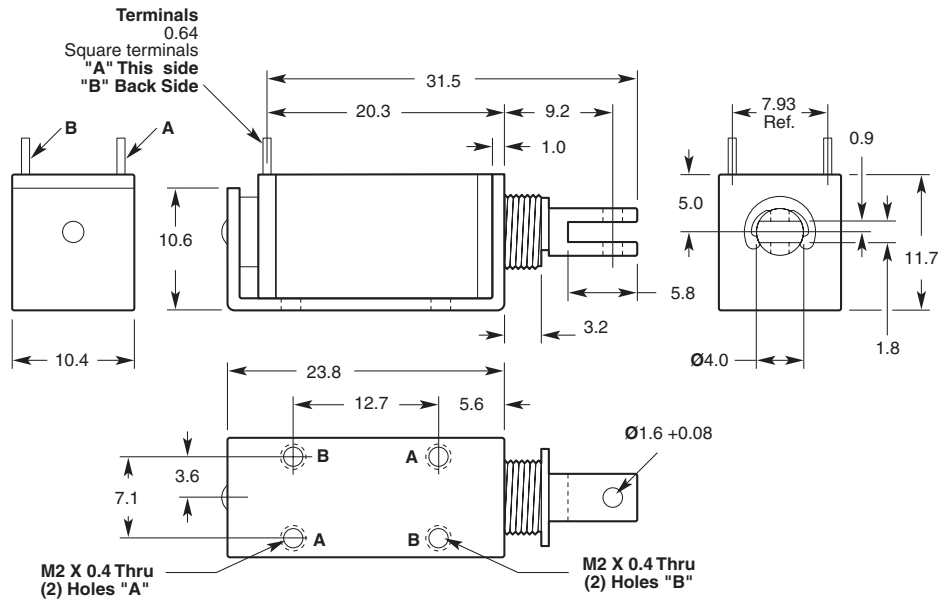

LINEAR Magnet Latch

All solenoids are illustrated in energised state

All specifications subject to change without notice.

## Ledex® Battery Operated Rotary & Linear Solenoids

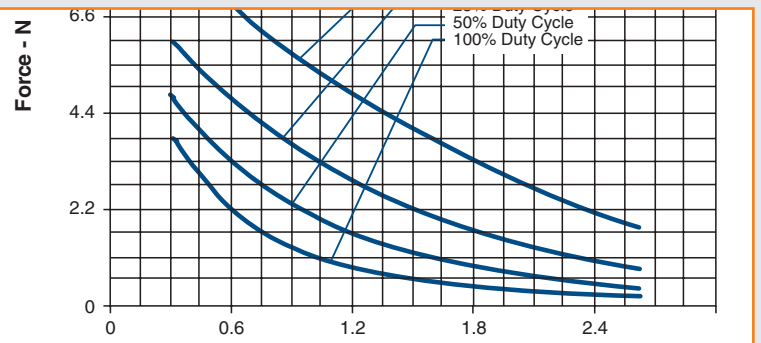

# Ledex® Battery Operated Solenoids



- Designed for intermittent duty cycle applications
- Magnetic latching models available for prolonged energised position applications
- Rotary designs available include BTA® and rotary solenoids with strokes up to 45°
- Linear designs include Soft Shift®, tubular, low profile and open frames with strokes up to 0.7 inches and force up to 3.8 lbs

## Linear Solenoid Designs:



### Soft Shift®

- Quiet operation
- Slow, smooth motion
- Snap action



### Tubular Solenoids

- Push or pull operation
- Well-suited to lock/latch operations
- Multiple plunger design
- On/off operation

## Battery Solenoid Selection

We offer many choices for battery operated Ledex® solenoids which provide a full range of specific design benefits.

Refer to the selection overview charts on page J6-8 for a complete listing of solenoids suitable for battery operation.

Selecting the appropriate solenoid in terms of force or torque and response time, the coil size (awg or resistance) must be made in conjunction with a battery set that will both provide the required length of service (number of solenoid cycles) and will provide adequate solenoid performance at the battery

voltage representing its end of life voltage.

To begin, determine the minimum voltage required for the solenoid to produce the specified force or torque for a particular coil resistance. Use this voltage to represent the end-of-life voltage of the battery set.

Refer to the manufacturer's data sheet to find the minimum, or end-of-life operating voltage per cell (typically this will be 1.0 volt for nickel cadmium and nickel metal hydride batteries). The solenoid wire size must then be selected to operate based upon this voltage times the number of cells in series.

## Rotary Solenoid Designs:



### BTA® Brushless Torque Actuator

- Quiet, shock-free operation
- High speed cycle rate
- Closed loop velocity
- Position control



### Low Profile Solenoids

- Push/pull engagement
- High force
- Short stroke applications
- On/off operation



### Rotary Solenoids

- Snap acting engagement
- Maximum versatility
- On/off operation
- Clockwise or counterclockwise



### Open Frame Solenoids

- Pull-in operation
- Continuous or intermittent duty
- On/off operation

Battery Operated

### NEED DESIGN HELP?

Our Application Engineers can help you decide which battery is right for your design needs using our proprietary battery calculator software.

Call us today to discuss your application requirements.



All catalogue products manufactured after April 1, 2006 are RoHS Compliant

# Ledex® Battery Operated Solenoids

## Solenoid Design Considerations

### Life

Life ratings vary depending on the solenoid design:

Life is rated at more than 100 million cycles for BTA; up to 50 million for rotary solenoids; 10 million for Soft Shift®, 2 million for tubulars; 50,000 to 100,000 for open frame designs.

### Power Requirements

Voltage applied to the solenoid must be matched to the coil wire size for proper operation. Solenoids are catalogued in coil awgs ranging from #25 up to #38 to accommodate your input power. Refer to the individual model specification pages for coil wire awg recommendations. Many other coil awg sizes are available. Please feel free to contact our application engineering department for availability.

### Performance Curves

The performance curves provided for individual products are used as guides to determine the solenoid size needed to produce a desired force at a given stroke, duty cycle, and power source. All curves were developed under the following standard test conditions: ambient temperature of 20°C, 65% relative humidity.

### Starting Force

When determining an application's force requirement, apply a 1.5 safety factor. For example: a load requiring 0.2 lb of force should utilise a solenoid providing  $0.2 \times 1.5$  or 0.35 lb of force.

### Duty Cycle

Battery operated solenoids are rated for intermittent duty cycle applications.

Duty cycle is determined by:  $\text{ON time} / (\text{ON} + \text{OFF time})$ .

For example: a solenoid is actuated for 30 seconds, then off for 90 seconds.

$$30 \text{ sec ON} / (30 \text{ Sec ON} + 90 \text{ sec OFF}) = 30/120 = 1/4 \text{ or } 25\% \text{ duty cycle.}$$

Note that maximum ON time for a particular application can be a factor which overrides the duty cycle rating. For example, at 25% duty cycle, the maximum ON time for a given Ledex solenoid is 36 seconds. If, however, the solenoid is operated at a cycle rate which enables the unit to return to ambient temperature between ON cycles, then the maximum ON time is extended somewhat. In the above example, this extended ON time is 44 seconds. Maximum ON time ratings are listed on the individual model specification pages.

### Options and Modified Designs

Even though many solenoid designs are in stock and available via distribution, our customers often require a product with unique features or performance capabilities. In fact, almost 80% of all solenoids that we make are either modified or custom built to meet our customers' exact application requirements.

So, if you don't find what you're looking for in the catalogue, give us a call to discuss your needs with one of our application engineers.

### Typical Examples of Custom Features

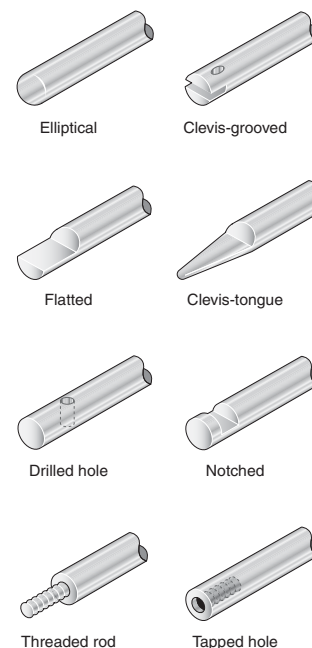

# Ledex® Battery Operated Solenoids

## Battery Powered Application Design Considerations

When applying solenoids for use in portable, remote, or back-up systems, the following considerations should be critically evaluated in the application.

- Solenoid and battery selection including capabilities and limitations
  - Calculation of battery life based on solenoid operating conditions
- Fundamentally, over the charge-lifetime of the batteries, the solenoid force and energizing response times will gradually decline as the battery energy is depleted. If the solenoid cycling time is rapid enough to cause an increase in the coil temperature, this also will cause a decrease in force and response.

### Battery Selection

Basic choices for batteries are nickel cadmium (NiCD), nickel metal hydride (NiMH), lead-acid, and lithium (Li). The NiCD and NiMH batteries should be used within a temperature range of 0°C and +45°C. Li batteries should be used at +20°C to +60°C. Lead acid batteries should be used at -40°C to +60°C.

Battery manufacturers advise that certain batteries should be discharged no lower than a given value to prolong the number of useful recharge cycles of the battery, referred to as the end-of-life voltage.

Batteries have a capacity rating expressed in mAh (milliampere-hours) to express their usable energy. Each type of battery has a recommended limit on its maximum discharge current which is expressed as a fraction or multiple of its capacity rating. For instance, a 1000 mAh battery with a recommended maximum discharge rate of 2 C should not be used at a current higher than  $(2 \times 1000) = 2000$  ma. (or 2 amps). Some batteries will show a C value up to 3 which would allow currents up to 3 amps in a 1000 mAh battery.

Therefore, a battery set and solenoid selection must be such that the end-of-life battery voltage will adequately drive the solenoid, and the circuit current should not exceed the mAh rating times the C factor.

A means for reducing the battery current is to place enough batteries in series so that the resulting solenoid resistance will limit the current below the maximum C level.

Prolonged useful charge life is enhanced by reducing the discharge current even lower if possible.

## Predicting Battery Charge Life

If the battery discharge rate is within the recommended limits shown on the battery data sheet, the mAh rating can be equated to the electrical energy consumed by the solenoid to compute the lifetime or number of solenoid actuations per battery charge.

As an example, consider a battery set having six size AA NiMH batteries in series which are used to drive a solenoid having a coil resistance of 4 ohms. Let the duty cycle be 75 ms 'on' and 500 ms 'off' and the capacity rating of each battery cell as 1000 mAh. (Note that with the batteries in series, each battery carries the same circuit current and the battery set capacity remains at 1000 mAh).

## Computing the C Factor:

The six batteries in series gives a fresh battery voltage of 7.2 volts. The starting coil current is then 1.8 amps (from Ohm's law).

The circuit current is then  $7.2 \text{ v.} / 4\Omega = 1.8$  amps (or 1800 mA). Then,  $C = 1800 \text{ mA} / 1000 \text{ mAh} = 1.8$ . This is lower than the manufacturer's allowable discharge rating of 2C and is therefore an acceptable battery selection.

## Computing the Solenoid Pulses:

For computing the number of solenoid cycles over the charge lifetime of the batteries, use the average useful voltage of the battery set (1.2 to 1.0 volts per cell) as given by  $V = 6(1.2 + 1.0) / 2 = 6.6$  volts. The battery output per solenoid pulse will

### Summary of Calculation Designations:

Designation	Definition
mAh	Battery rated capacity in milliampere-hours
C	Battery discharge rate factor as a fraction or multiple of battery rated capacity; $C = 1000 \cdot i / \text{mAh}$
$V_b$	Battery rated voltage x no. of cells
$V_c$	Battery end-of-life voltage x no. of cells
Q	Solenoid current x time per solenoid pulse; $Q = i \cdot T_{on}$ (ampere-seconds)
R	Solenoid resistance (can be factored for ambient or running temperature) in ohms.
i	Mean solenoid current as computed: $i = (V_b + V_c) / 2R$ (A)
$T_{on}$	On time of a solenoid pulse (seconds)
$T_{off}$	Off time of a solenoid pulse (seconds)
N	Number of solenoid pulses per battery charge; $N = \text{mAh} \cdot 3600 / (Q \cdot 1000)$
L	Life time per battery charge; $L = N(T_{on} + T_{off})$ (seconds).

# Ledex® Battery Operated Solenoids

be  $Q = 6.6v / 4 \Omega \times 0.075$   
 sec. = 0.12375 amp-sec  
 = 0.034375 mAh. The  
 battery life is then  $1000$   
 mAh/0.034375 mAh/pulse  
 = 29090 solenoid pulses.  
 Since each solenoid period  
 is 75 ms + 500ms = 575  
 ms (or 0.575 seconds)  
 then the life time = 29090  
 pulses x 0.575 sec./pulse =  
 16726.75 seconds or 4.64  
 hours.

## Recommendations and Comments

Read the manufacturer's data sheet prior to selecting a battery type and size. Note the temperature ratings, charge and discharge limitations, and all handling and usage safety precautions.

Do not connect batteries in parallel to increase the mAh capacity. Select a larger battery size or consult with the manufacturer if an increased capacity is needed to extend the time between charging periods.

Note the manufacturer's limitation on the number of batteries placed in series.

The calculations in this section do not directly address the temperature

increase in the solenoid coil during operation. An increase in coil temperature will tend to prolong battery life but will tend to decrease the solenoid force or torque. This item may need to be addressed if the coil temperature will be significantly higher or lower than 20°C.

Battery life will be greatly improved by the use of PWM electronics if the solenoid must pull-in and then hold for a sustained time. The holding current is often much lower than the driving current if the solenoid's air gap closes at the end of the stroke. The number of solenoid cycles and lifetime per battery charge is then calculated as follows below. Refer to Figure 1 for a typical drive pulse + pwm signal.

Calculate the pwm duty cycle by  $f = T_a / (T_a + T_b)$ . Let T = the total time of one drive pulse + pwm time + off time as depicted.  $T_{on}$  is the initial full power drive pulse time and  $T_p$  is the pwm signal duration.

Then,  
 $Q = (V_b + V_c) / 2R \cdot (T_{on} + T_p \cdot f)$ ;  
 $N = \text{mAh} \cdot 3600 / (Q \cdot 1000)$ ;  
 $L = N \cdot T$ .

## Sample Calculation for PWM Drive & Hold Pulse

### Inputs for the Equations:

Solenoid Resistance: 11.52 ohms.

Battery Set: (5) Nickel Cadmium cells in series having a capacity rating of 1000 mAh.

- $V_b = 5 \times 1.38v = 6.9$  volts (battery rated voltage).
- $V_c = 5 \times 1.2v = 6$  volts (battery end-of-life voltage).
- $T_{on} = 75$  milliseconds (0.075 sec.).
- $T_a = 5$  milliseconds (0.005 sec.; pwm on time).
- $T_b = 15$  milliseconds (0.015 sec.; pwm off time).
- $T_p = 30$  seconds (On pulse plus pwm time).
- $T = 60$  seconds (total period of a solenoid on/off cycle).

The equations for reference:

$$f = T_a / (T_a + T_b) \text{ (pwm duty cycle)}$$

$$Q = (V_b + V_c) / 2R \cdot (T_{on} + T_p \cdot f); \text{ consumed battery energy in amp-seconds.}$$

$N = \text{mAh} \cdot 3600 / (Q \cdot 1000)$ ; Number of cycles obtainable.

$$L = N \cdot T; \text{ Life time per battery charge (seconds)}$$

The pulse train:

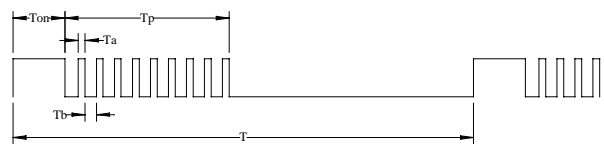

Fig.1 - PWM Drive & Hold Pulse

Then:

$$f = \frac{0.005}{(0.005 + 0.015)} = 0.25 \text{ (25\% duty cycle for hold-in)}$$

$$Q = \left( \frac{6.9 + 6}{2 \cdot 11.52} \right) (0.75 + 30 \cdot 0.25) = 4.241 \text{ amp-sec}$$

$$N = \frac{1000 \cdot 3600}{4.241 \cdot 1000} = 849 \text{ cycles (based upon 1000 mAh batteries)}$$

$$L = 849 \cdot 60 = 50,940 \text{ seconds (14.15 hours) battery life}$$

## NEED DESIGN HELP?



Our Application Engineers can help you decide which battery is right for your design needs using our proprietary battery calculator software.

Call us today to discuss your application requirements.

# Ledex® Battery Operated Rotary Solenoids

## BTA® Selection Overview

(see Section C for complete product information)



BTA rotary, non-axial stroke actuators are a good solution for applications requiring reliable, low hysteresis operation with a good torque profile. Offering maximum design flexibility across a wide

range of stroke angles and torque requirements, the BTA actuator offers considerably more torque than comparable sized rotary actuator designs. The BTA requires only milliseconds to rotate

through its entire stroke. It can maintain this extremely fast operating speed repetitively without diminishing accuracy or repeatability, or reducing the overall life of the unit.

Size	Package Dimensions (mm)		Maximum Stroke (degrees)	Gross Starting Torque (mNm) @ Specified Duty Cycle				Gross Ending Torque (mNm) @ Specified Duty Cycle				Page
	Dia.	Length		100%	50%	25%	10%	100%	50%	25%	10%	
2EVM	30.2	18.3	45	N/A*	31.6	56.5	113.0	N/A*	21.5	37.3	65.5	C5

All data is at 20°C coil temperature.

Torque outputs degrade with elevated temperatures. Typical spring torque is 1 oz-in.

\* Not recommended for 100% duty.

## Rotary Solenoids Selection Overview

(see Section D for complete product information)



Elongated rotary solenoids are built with 30% more coil copper than precision standard coil solenoids for lower power consumption and excellent torque to size ratio.

Models are available in standard or long life versions: one million operations life rating for standard versions;

50 million operations or 100 million operations if lubricated every 10 million operations for long life versions.

Series	Package Size/ Dimensions (mm)**		Stroke	Direction		Holding Torque (mNm)	Available Torque*** (mNm) @ Specified Duty Cycles					Energizing Time*** (msec) @ Specified Duty Cycles					Return Spring (mNm)	Page	
	Dia.	Length		CW	CCW		100%	50%	25%	10%	5%	100%	50%	25%	10%	5%			
1E	25.40	15.80	25°	•	•	33.9	*	22.6	45.2	90.4	124.3	12.6	9.9	7.3	5.7	4.7	6.8	D10-11	
			45°	•	•	22.6	*	11.3	22.6	45.2	67.8	19.8	14.2	10.0	7.2	6.0	6.8		
2E	1.125	0.656	25°	•	•	56.5		22.6	45.2	79.1	158.2	192.1	13.1	9.5	7.5	5.9	5.0	6.8	D12-13
			35°	•	•	*	22.6	33.9	56.5	124.3	146.9	*	*	*	*	*	*		
			45°	•	•	33.9	11.3	22.6	45.2	79.1	101.7	23.2	15.0	11.0	8.4	7.0	6.86		

All data is at 20°C coil temperature. Torque outputs degrade with elevated temperatures.

\* Consult factory.

\*\* Without armature cover

\*\*\* Torque values and energizing times shown are for standard life. Long life models provide approximately 10% less torque, but offer 5 to 10 times longer life

### NEED DESIGN HELP?

Our Application Engineers can help you decide which battery is right for your design needs using our proprietary battery calculator software.

Call us today to discuss your application requirements.



# Ledex® Battery Operated Linear Solenoids

## Soft Shift® Selection Overview

(see Section E for complete product information)



Soft Shift solenoids have a unique construction which allows easy transition from snap action to velocity controlled.

Using the same power, starting force is three to five times higher than standard solenoids at the fully de-energised position.

This is advantageous for starting inertial loads or detented mechanisms, and for conserving electrical power.

Size	Package Dimensions (mm)		Maximum Stroke (mm)	Force (N) @ Maximum Stroke and Specified Duty Cycle				Page
	Dia.	Length		100%	50%	25%	10%	
2EPM	28.6	25.3	4.1	4.45	6.23	8.9	16.91	E5

All data is at 20°C coil temperature. Force outputs degrade with elevated temperatures.

## STA® Tubular Selection Overview

(see Section F for complete product information)



In the pull type tubular design, the plunger is pulled into the solenoid coil when the coil is energised. In Push type solenoids, the same is true, however, the plunger has

a shaft extension which then pushes out through a hole in the end of the solenoid case. Please note, however, that the magnetic field cannot

be reversed to cause the opposite action to occur.

The tubular design offers the most compact package size to force ratio and very long life.

Size	Solenoid Type	Package Dimension (mm)		Max Stroke (mm)	Nominal Stroke (mm)	Force (N) @ Nominal Stroke and Specified Duty Cycle				Page
		Dia.	Length			100%	50%	25%	10%	
STA 13 x 14	Pull	13.2	13.9	2.5	1.3	0.80	1.33	2.22	4.45	F6-7
STA 13 x 16 Latching	Pull- Latching	13.2	15.7	3.8	1.9	N/A	1.11	2.14	3.34	F8-9
STA 13 x 14	Push	13.2	13.9	2.5	1.3	0.80	0.80	1.11	2.67	F10-11
STA 13 x 27	Pull	13.2	26.7	12.7	2.5	0.84	1.38	2.49	4.45	F12-13
STA 13 x 27	Push	13.2	26.7	12.7	2.5	0.58	1.11	2.14	4.18	F14-15
STA 20 x 40	Pull	19.6	39.4	17.8	5.1	2.22	4.45	7.25	11.97	F16-17
STA 20 x 40	Push	19.6	39.4	17.8	5.1	1.69	3.56	6.68	12.24	F18-19

All data is at 20°C coil temperature. Force outputs degrade with elevated temperatures.

### NEED DESIGN HELP?

Our Application Engineers can help you decide which battery is right for your design needs using our proprietary battery calculator software.

Call us today to discuss your application requirements.



# Ledex® Battery Operated Linear Solenoids

## Low Profile Selection Overview

(see Section G for complete product information)



The low profile shape, besides contributing to smaller size, optimises the magnetic flux paths for maximum force versus stroke characteristics.

The construction of the plunger assembly provides an auxiliary flux path which permits a significant increase in force.

Size*	Package Dimensions (mm)		Max Stroke (mm)	Nominal Stroke (mm)	Force (N) @ Nominal Stroke at Specified Duty Cycle @ 20°C				Page
	Dia.	Length			100%	50%	25%	10%	
OECM	19.0	12.7	3.81	1.5	0.9	2.0	4.2	9.2	G5
1ECM	25.4	13.5	6.10	2.0	1.1	2.2	5.6	14.2	G6
2ECM	28.6	14.7	6.10	2.5	1.1	4.5	8.9	16.7	G7

All data is at 20°C coil temperature. Force outputs degrade with elevated temperatures.

\* EC sizes have conical face plungers.

## Open Frame Selection Overview

(see Section H for complete product information)



### Box Frame

This solenoid has a 4-sided closed box frame and solid plunger and is, therefore, more electrically efficient than the C Frame solenoid. The closed, box frame also provides improved mechanical strength.

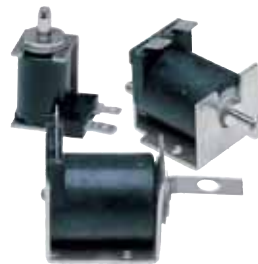

### C Frame

C Frame solenoids consist of a formed C-shaped steel frame and solid plunger. Therefore, these solenoids are less efficient and less costly than their Box Frame counterparts.

Size	Frame Type	Coil Type*	Height (mm)	Width (mm)	Length (mm)	Max. Stroke (mm)	Nominal Stroke (mm)	Typical Force (N)		Page
								Nominal Stroke and 100% Rated Voltage @ 100% Duty	25% Duty	
B14M	Box	T	25.9	20.1	36.8	15.2	5.1	2.2	8.5	H8
B14M-L	Box - Latching	T	25.9	20.1	36.8	15.2	2.5	N/A	8.9	H9
B16M	Box	T	12.2	9.9	25.1	3.8	1.3	0.4	1.3	H10
B16M-L	Box - Latching	T	12.2	9.9	25.1	3.8	1.3	N/A	0.7	H11
B17M	Box	T	15.0	13.0	24.1	4.6	1.3	0.9	2.7	H12
B17M-L	Box - Latching	T	15.0	13.0	28.4	4.1	2.0	N/A	1.3	H13
B20M	Box	T	23.9	20.6	29.0	12.7	6.4	0.4	1.8	H14
B75MM	Box	T	27.9	25.4	41.4	15.2	5.1	4.9	15.1	H20
C5M	C	T	11.7	10.4	23.9	5.1	1.3	3.1	0.9	H21
C5M-L	C - Latching	T	11.7	0.4	23.9	5.1	1.3	N/A	1.8	H22
C8M	C	OM	20.6	19.1	28.7	12.7	6.4	0.2	1.3	H23
C15M	C	T	25.4	26.9	29.0	12.7	6.4	0.4	2.7	H25

\* OM = Overmolded; T = Taped

All data is at 20°C coil temperature. Force outputs degrade with elevated temperatures.

### NEED DESIGN HELP?

Our Application Engineers can help you decide which battery is right for your design needs using our proprietary battery calculator software.

Call us today to discuss your application requirements.



## Ledex<sup>®</sup> Drive Electronics and Coil Suppressors

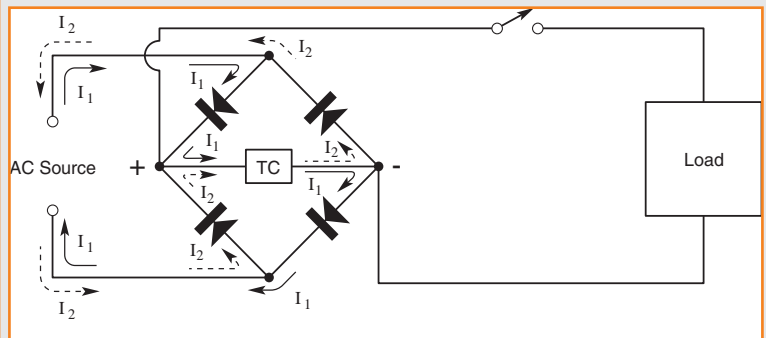

# Ledex® Coil Suppressors

A voltage is generated by a changing magnetic field in proximity to a current-carrying member. The equation  $E = -N^{d\phi}/dt$ , describes this by saying that the magnitude of the voltage is proportional to the number of turns (N), i.e., of a coil, and the rate of change of a magnetic field. This theory can be easily demonstrated by hooking a coil of wire to a voltmeter and passing a magnet through it. It can be observed that the faster the magnet moves, the higher the voltage. Essentially, the same theory applies when making a generator.

Reading the equation the other way suggests that if a voltage is applied to a coil of wire, a change in the magnetic field will occur; i.e., before the voltage is applied, no field exists. Applying a voltage will cause a field to be generated, which will be maintained as long as the voltage is applied. When the voltage is removed, the field must dissipate.

Nearly everyone is familiar with spark plugs in gasoline engines. A spark is generated due to a voltage between the contacts which is higher than the dielectric strength of air (which has a dielectric strength of approximately 40 volts/mil). If a spark plug is gapped at 0.025", a voltage of  $25 \times 40 = 1,000$  volts would be necessary to create a dielectric breakdown (spark).

How is more than 1,000 volts generated from a 12-volt automobile battery? A coil is charged with 12 volts, and when that voltage is removed, a voltage is created which is dissipated across the gap of the spark plug.

This is similar to the operation of a solenoid, except the voltage generated is not useful in a typical solenoid circuit. In most cases, voltages of that great a magnitude would be damaging if not correctly suppressed. Damage can appear as a transfer of material, to welding of hard contacts, to destruction of the switching transistors junction, to even causing a dielectric breakdown of the coil insulation.

Ledex coil suppressors minimise contact arcing and suppress the reverse voltage transient to safe levels to protect semiconductor switches. Coil suppressors should be used with all DC solenoid and relay coils to protect associated circuitry and to aid in minimizing electromagnetic interference (emi).

Note in Figure 1 that switching on the AC side of the rectifier also slows the drop-out time of a solenoid which is advantageous for improved life of the solenoid. If drop-out time is critical, the solenoid must be switched on the DC side and a high-speed coil suppressor should be connected across the solenoid coil.

Refer to Figure 2, which shows a typical coil suppressor connection noting the polarities of the power source and suppressor.

Coil suppressors are designed for operation from  $-55^{\circ}\text{C}$  to  $80^{\circ}\text{C}$ , with special models designed for  $125^{\circ}\text{C}$  incorporating JAN-rated electronic components.



Figure 1. Switching on AC Side

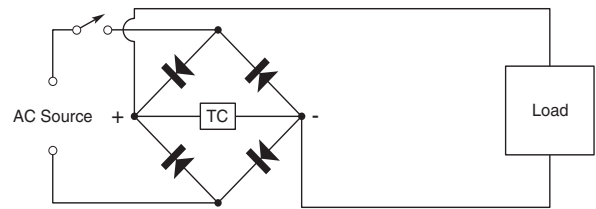
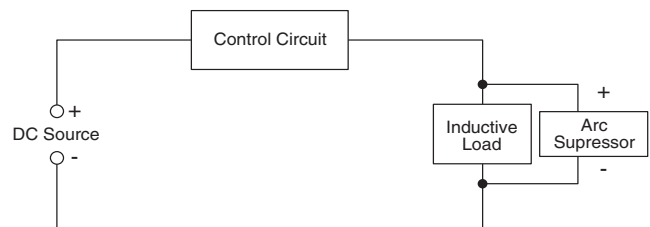

Figure 2. Coil Suppressor Connection



## Oscilloscope trace depicting coil suppression



LEFT: Typical trace with capacitor as coil suppressor when 28 volt pulse to inductive load is interrupted. Collapsing magnetic field can generate a spike in excess of 350 volts. Spikes can short capacitors, cause coil burnout or damage other circuit components.



load interrupted under identical conditions, but with coil suppressor No. 122654-001 connected in parallel with coil. Results:

- Eliminate arcing
- Extended contact life
- Minimise transients
- Protects other circuit components

# Ledex® Coil Suppressors

## Diode/Capacitor Design

Use Type A diode/capacitor designs when the lowest peak reverse voltage is required and when highest operating speed is not necessary.

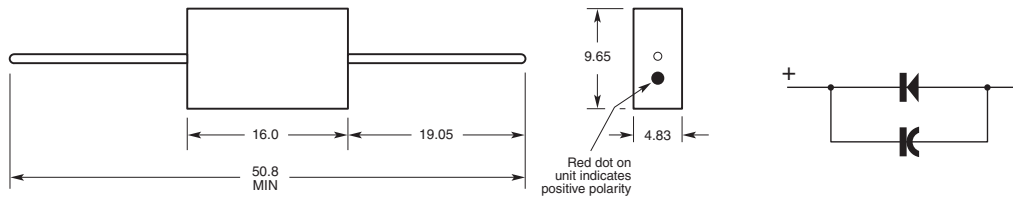

### Type A

Part Number 122654-001 (not RoHS Compliant)

Part Number 122655-001 (not RoHS Compliant)

## Diode/Capacitor/Zener Design

Use these models when highest operating speed is required and when lowest peak reverse voltage rating is not necessary.

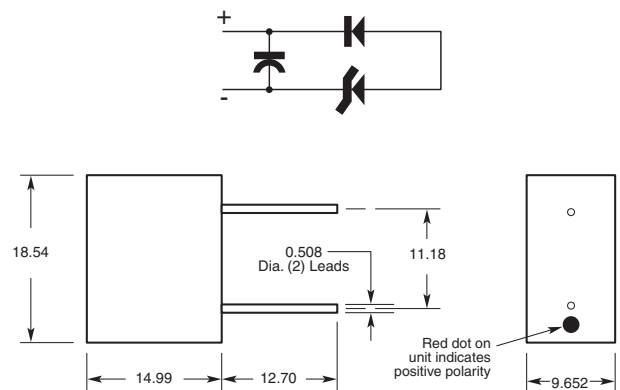

### Type C

Part Number 190805-001

Part Number 190810-001

Coil Suppressor Type (not RoHS Compliant)	Maximum Operating Voltage	PIV Peak Inverse Voltage (VDC)	Use with Ledex Solenoids (VDC)	Diode Capacitor Type (Size)	Part Number
Diode/Capacitor	33	1	1-8	A	122654-001
Diode/Capacitor	200	1	1-6 *	A	122655-001
Diode/Capacitor/Zener	33	10	1-8	C	190805-001
Diode/Capacitor/Zener	200	36	1-6 *	C	190810-001

\* Suppression of arcing on hard switch contacts can be supplemented by placing a 0.05 mfd, 200 volt (min.) capacitor across the contacts in addition to our coil suppressor across the load.

# Ledex<sup>®</sup> Rectifiers

Ledex<sup>®</sup> Rectifiers whose DC terminals are connected to the solenoid coil are self suppressing when switched on the AC side of the rectifier. In addition, Ledex rectifiers employ AC line transient suppressors to protect from incoming voltage spikes. Hard contact switches can be supplemented by adding a 0.05 to 0.1 mfd, 200 volt (min.) capacitor across the contacts to further minimise contact arcing.

Efficient, light, and exceptionally reliable, Ledex transient protected silicon bridge rectifiers have built-in transient control. High voltage spikes on either AC or DC sides are automatically clipped at 200 volts, protecting the diode cells as well as other circuit components.

Our silicon bridge rectifiers are carefully constructed and sealed to meet general requirements of military specification MIL-E-5400 on insulation, terminals, vibration, shock, sand and dust, fungus, and salt atmosphere.

They are recommended for use with all our electromechanical products, as well as for other systems which may be subjected to high voltage spikes from solenoids, relays and other inductive equipment sharing a common AC line. Storage and ambient temperature range is -55°C to 120°C.

## Transient Protection

One of the early problems associated with the introduction of semiconductors was the destruction of diode cells and other circuit components by transients generated from collapsing magnetic fields.

A transient spike in the high resistance direction and beyond the diode PIV rating destroys the diode. In a silicon bridge, destruction can occur from transients generated by the inductive load or from other points on the AC system.

Low Resistance,  
High Current Capacity,  
Low Voltage Drop

High Resistance,  
Leakage Current Only. High  
Voltage Drop (Limited by PIV)

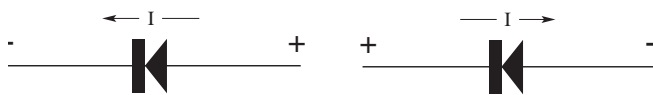

To prevent current flow in the inverse direction, our silicon rectifiers have a low resistance shunt control built across the DC terminals. It allows the energy of the transient from the AC side to be dissipated through the forward direction of the diodes, protecting the rectifier as well as other circuit components. Transients from the DC side are dissipated directly through the built-in control device.

When there is only a minor possibility of transients from the AC side of a silicon rectifier, the need for transient protection may be eliminated by placing the control switch on the AC side. In this way the rectifier is closed only when the load is energised, and the possibility of damage by transients is greatly reduced.

Consideration should be given to the slower operating speed that results when an inductive load is switched from the AC side.

## Oscilloscope Trace of Transient Protection



LEFT: Actual wave form read from DC output of unprotected full wave silicon bridge rectifier powering an inductive load. To prevent cell destruction, 1500 PIV (IN-1150) diodes were used. Typical DC output of bridge appears between 0 and 165 volts.

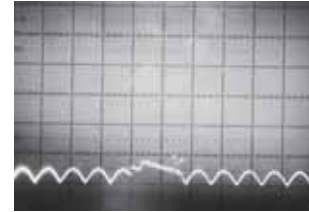

RIGHT: When transient protection circuitry is added to the DC output, the 1400 volt transients are leveled to a safe 250. (These tests were conducted with a Tektronix 535 oscilloscope with 10-to-1 attenuated probe.)

## Transient from AC Line

Transients from the AC line flow through forward direction of two diodes and transient control. Forward direction can withstand the flow. Without protection, flow would be through inverse direction, resulting in diode damage.

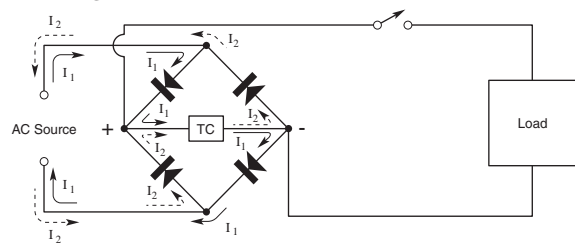

## Transient from DC Load

Transients from the DC load bypass diodes by going through transient control. If transient control is removed, current path is through inverse direction of diodes.

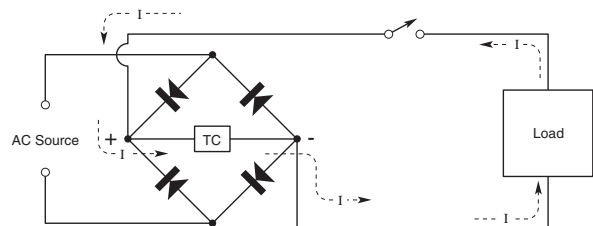

# Ledex<sup>®</sup> Rectifiers

## Octal Plug-In

Part Number A-46502-003 (not RoHS Compliant)

Weight: 46 grams

Mates with standard octal tube socket such as Cinch-Jones 8AB or equal.

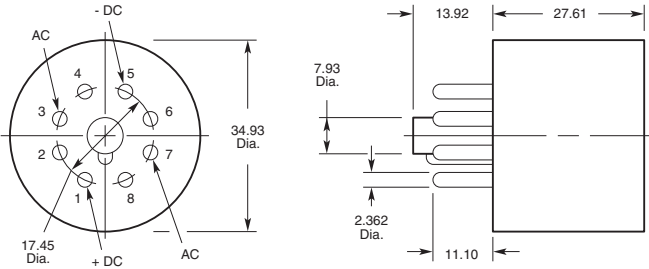

Viewed from base; locate from key

Part number 174488-001 is identical to A-46502-003 except that it has no built-in transient protection. If used with an inductive load, switching should be done on the AC side only. To switch on the DC side would require some provision to suppress transients within the 400 PIV rating. This model may also be used for applications requiring 220 VAC.

## Quick Connect

Part Number 121011-001 (not RoHS Compliant)

Weight: 42.5 grams

Mates with AMP, Inc. Series 250 (Faston) or equivalent 1/4" terminals.

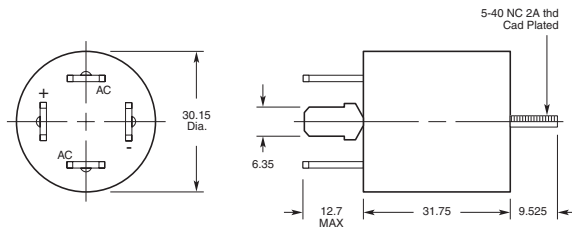

Mounting nut and lockwasher supplied loose

## Typical Rectifier Hook-up

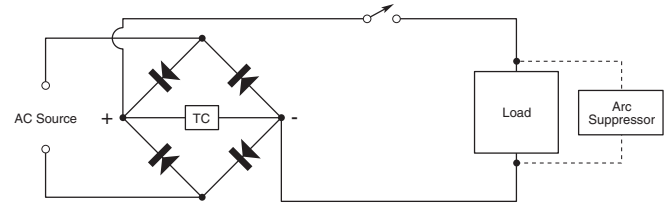

TC = Transient Control (Built-In)

Input (50-400 Hz)		Output (VDC)
VRMS	Surge (amps)	
24	25 for 1 cycle	20
115	25 for 1 cycle	100
140	25 for 1 cycle	124

## Current Rating by Duty Cycle

Duty Cycle %	20° to 75°C		100°C	
	Max Current (Amps)	Max Pulse Length (Sec)	Max Current (Amps)	Max Pulse Length (Sec)
100	1.8	Cont.	0.75	Cont.
75	2.4	115	1.0	115
50	3.6	100	1.5	100
25	7.2	43	3.0	43
10	7.5	20	4.0	20

## Maximum Ratings (25°C Ambient)

Rating	Value
RMS applied voltage	139 VRMS
Recurrent peak voltage	184 volts
DC applied voltage	175 volts
Average rectified forward current at 60 Hz	1.8 amp
Non-repetitive peak surge current for 1 cycle	30 amp
Average transient energy dissipation	20 joules
Peak transient current on DC side of bridge (current spike $t_p < 20 \mu\text{sec}$ )	1,000 amps
Operating temperature	-55°C to 115°C

## Electrical Characteristics

Characteristic	Typical	Max
Forward voltage drop ( $I_F = 1.0 \text{ amp}; T = 25^\circ\text{C}$ )	1.8	2.2 volts
Transient voltage clipping level		273 volts

NOTE: The output of the rectifier should not be grounded unless the input is isolated from the power line by a transformer.

# Ledex<sup>®</sup> AC Hold-In Circuit Modules

These convenient modules provide solutions to applications requiring high starting torque but lower holding torque at the end of the rotary stroke. The modules rectify 115 VAC input and supply 100 VDC to the solenoid to move your load, then reduce the wattage to a lower power level to hold the solenoid in the energised position. These modules use pulse width modulation to reduce the effective voltage to the solenoid to about 35%. Model 129549-001 switches an external resistor in series with the solenoid.

## Hold-In Module for PWM Operation (Pick and Hold)

Part Number 152160-001

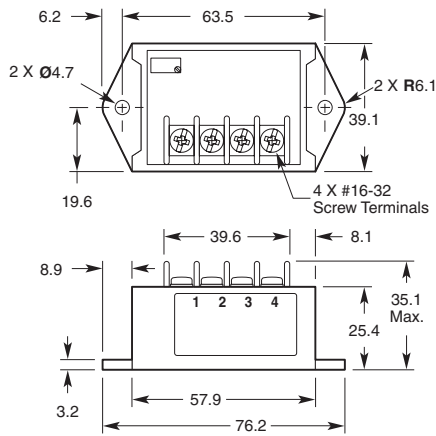

- Delivers full power for 50 milliseconds ( $\pm 20\%$ ), then reduces voltage to a user-selected range of 10% to 75% full voltage input (approximately 10% factory setting.)
- Operating voltage is 12 - 24 VDC input
- Black ABS plastic housing with terminal strip connections
- Operating temperature is 0°C to 50°C
- Suitable for use on Ledex size 5 solenoids or smaller
- Potentiometer adjustment of hold-in voltage/current
- Not RoHS compliant

Input Voltage Range:	11-26 VDC
Maximum Holding Current:	1.0 amps
Maximum Pull-In Current:	8.0 amps
Minimum Load Resistance:	3.3 ohms @26 VDC input
Holding Current (approximate):	$V_{in} \times \text{duty cycle} / \text{coil resistance}$
Maximum Repetition Rate:	Once every second

**Operation:** The hold-in module is connected permanently to the solenoid leads. Upon application of DC power to the input terminals, full power is delivered to the solenoid for 50 ms. Power is then reduced automatically to a user-selected value (10 to 75% of full input voltage). This reduced hold-in voltage is maintained until the input voltage to the module is turned off. This action removes power to the solenoid and enables the module for a new cycle of full power and automatic reduction (pick and hold).

## Hold-In Circuit Module for PWM Operation (Pick and Hold)

Part Number 187478-001 (not RoHS Compliant)

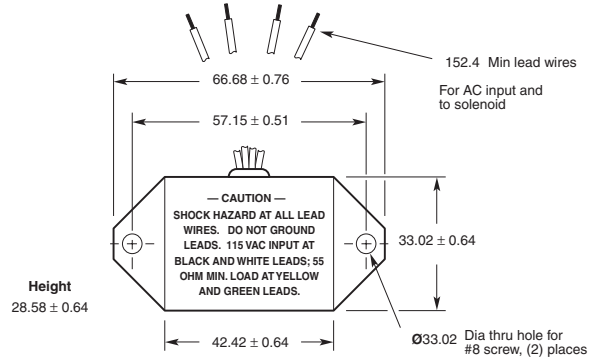

- Built-in full wave rectifier
- AC line transient protection
- Delivers full power to solenoid for 125 milliseconds, then reduces voltage to 35%
- Built-in solenoid coil suppression

Rating	Min	Typical	Max	Unit
Input voltage	95	115	135	Volts AC
Energising pulse width	85	125	175	Millisec
Load resistance	30			Ohms
Holding current*	$0.9E-2.5$			Amps
	$2.86R$			
Operating temperature	0		+71	°C

\* The holding current following the initial energizing pulse is computed by the above equation where E is the supply voltage (AC) and R is the solenoid resistance.

**Operation:** The hold-in circuit is connected permanently to the solenoid by means of the yellow and green lead wires. Upon application of AC power to the black and white lead wires, full power is applied to the solenoid for approximately 125 ms. The power then automatically drops to provide holding current until the AC power is removed.

A solenoid is a basic, rugged device. Its component parts consist of a coil (to carry current and generate ampere turns), an iron shell or case (to provide a magnetic circuit), and a movable plunger or pole (to act as the working element).

A major objective in the design of a solenoid is to provide an iron path capable of transmitting maximum magnetic flux density with a minimum energy input. Another objective is to get the best relationship between the variable ampere turns and the working flux density in the air gap. When applying a solenoid, it is extremely important to consider the effects of heat, since for a constant voltage application, an increase in coil temperature reduces the work output.

Ambient temperature range, voltage fluctuation, return springs and temperature rise all affect the net output torque/force. For preliminary calculations, we recommend that a 1.5 safety factor be applied to the variables.

## Magnetic Flux

Magnetic flux lines are transmitted through the iron shell and the air gap between the shell and the plunger (for linear solenoids) or the armature (for rotary solenoids). An iron path is much more efficient than air, but the air gap is needed to permit movement of the plunger or armature.

The force or torque of a given solenoid is inversely proportional to the square of the distance between the pole faces. The lowest force or torque is generated when the distance is widest/longest; the strongest when the distance is smallest.

## Saturation

Saturation of the iron path in a solenoid can be considered in two ways. In the true sense it is point (a) at which the iron ceases to carry any increase in flux. In broader terms, saturation is usually considered as point (b), where the iron begins to saturate.

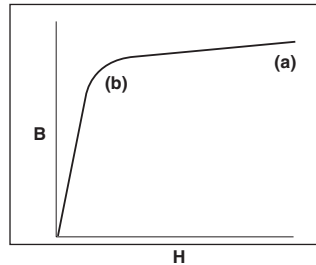

As the pole pieces are moved together or when input power is increased, the flux density of the magnetic circuit increases until the iron saturates near point (b). Beyond this point any further increase in power only serves to add heat without an appreciable increase in force or torque. By changing the iron path area, the pole shape, or the magnetic circuit material, output torque/force can be increased.

## Ampere Turns

The number of copper wire turns, the magnitude of the current, and permeance of the magnetic circuit determine the absolute value of magnetic flux within the solenoid. The permissible temperature rise limits the magnitude of the power input. When using a constant voltage, heat makes the coil less efficient because it reduces the ampere turns and, hence, the flux density and the torque/force output.

## Heat

Heat can be dissipated by controlling the air flow, by mounting the solenoid on a surface large enough to dissipate the energy (heat sink), or by resorting to

some other cooling method. When space permits, a simple solution is to use a larger solenoid. Heat in a solenoid is a function of power and the time during which power is applied. For continuous duty, hold-in resistor circuits are commonly used to provide higher starting torques/forces than are obtainable at continuous duty rating.

Our stock model standard solenoids are designed to operate in ambient temperatures of -55°C to 80°C. A solenoid operating at the predetermined conditions established in the coil data charts, with the specified heat sink, will have a coil temperature rise of about 80°C (above ambient temperature). Our standard solenoids will withstand 120°C without thermal damage. A special high temperature coil with a 175°C temperature limit, for operation in up to 95°C ambient, is available for rotary and low profile solenoids.

## Duty Cycle

Duty cycle is determined by ON time/(ON + OFF) time. For example, if a solenoid is energised one second out of four seconds, the duty cycle is  $1/(1 + 3) = 1/4$  or 25%. Duty cycle is the time factor which determines the permissible watts input and the subsequent amount of torque/force and heat. If, for example, a 10-watt input power causes a heat rise of 20°C in 10 seconds, approximately the same temperature rise will result if a power of 100 watts is applied for one second. In terms of duty cycle, a solenoid designed for continuous duty can dissipate ten times the input power at 10% duty.

## Maximum ON Time

Solenoids have a maximum ON time for a given duty cycle, wattage and power input. For example, if a solenoid is energised for one second out of four (25% duty cycle), its ON time is one second, which will cause no damage. On the other hand, if the solenoid is energised for 10 minutes out of every 40 minutes at the 25% duty cycle wattage, the duty cycle is still 25%, but its ON time is now 600 seconds. A single pulse of this duration would burn out the solenoid. Ledex DC solenoids are specified with two criteria for maximum ON time: when pulsed repeatedly at the stated watts and duty cycle, and; for a single pulse at the stated watts (with the coil at 20°C ambient temperature).

## Operating Speed

The energizing time for a solenoid to complete a given stroke is measured from the beginning of the initial pulse to the seated or energised position. For a given solenoid, this time is dependent upon the load, duty cycle, input power, stroke and temperature range. When a DC voltage is impressed across the solenoid coil, the current will rise to point (a) as shown on the graph below.

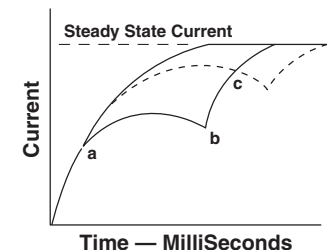

This time delay, which occurs prior to the plunger motion, is a function of the inductance and resistance of the coil, and the flux required to move the armature against the load. An increase in the magnetomotive force is

# Technical Data

gap (change in inductance) as the plunger moves through the stroke, causing a dip in the current trace. The cusp at point (b) indicates that the solenoid has completed the stroke. The current trace then begins to rise to a steady state current value which, by Ohm's law, is  $I = E/R$ .

The current trace of a solenoid can be observed on an oscilloscope by monitoring the voltage drop across a low resistance, high wattage resistor in series with the solenoid coil.

At point (a) the solenoid has developed sufficient flux to move the load. As the load increases, more time is required to reach point (c), as shown by the phantom current trace. If the load is greater than the output of the solenoid, then the coil will build to a steady state value and a dip in the trace will not occur since the plunger has not moved (top curve).

More time is required to complete the stroke within the force limits of the solenoid as the load increases, the power decreases, or the ambient temperature increases, since these factors affect the net force of the solenoid.

When selecting a solenoid for an application, it is important that these variables be taken into consideration to determine the maximum length of the ON pulse. Once the nominal energizing time has been established, sufficient ON time beyond point (b) should be allotted to compensate for the change in speed due to the maximum load, minimum voltage, and maximum coil temperature.

The length of the OFF time or interval between pulses is established by the duty cycle and the input power. If a pulse train is applied for an indefinite period, the interval between pulses should be sufficient to maintain the duty cycle for the input power and wire size tabulated in the coil data tables. Response to a faster pulse rate for intermittent operation is then limited by the temperature rating of the coil and the return speed of the plunger. The return speed can be established by reducing the OFF period until the solenoid energizing trace becomes erratic.

When designing for high speed pulse trains, it is important to consider the type of coil suppression used, and the location of the control circuit.

A diode across the coil may provide satisfactory coil suppression, but it causes a slower collapse of the magnetic field, lengthening the OFF interval required. Ledex high speed coil suppressors use a diode/capacitor/zener diode principle to decrease the drop-out time as well as effectively suppress transients. Placing the control switch to the solenoid on the AC side of a rectifier will have an effect similar to that of using a diode across the coil. If de-energizing speed is critical, the control switch should be located on the DC side of the rectifier and a high speed coil suppressor should be used to provide adequate suppression while allowing fast plunger return speed.

## Continuous Duty

For continuous duty applications, or where there is a chance that an operator might close the control switch for a long period, the project engineer has several choices. He can specify a solenoid large

enough to provide the torque/force needed on a continuous basis or, if the application permits a higher coil temperature rise, he can specify a smaller solenoid with a high temperature coil to obtain continuous duty operation at a higher power level. He can also use a smaller solenoid and

take advantage of the higher torque/force obtainable with an intermittent duty cycle input power. This can be accomplished by using a hold-in circuit to reduce current to a point where torque/force is sufficient to maintain the solenoid in the energised position.

## "Hold-in" Resistor Value Estimates

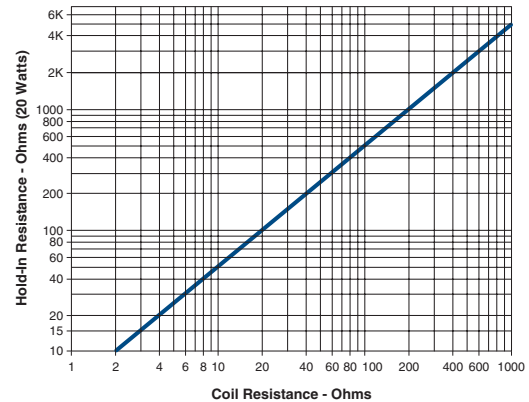

### Mechanical Hold-in Resistor Circuit

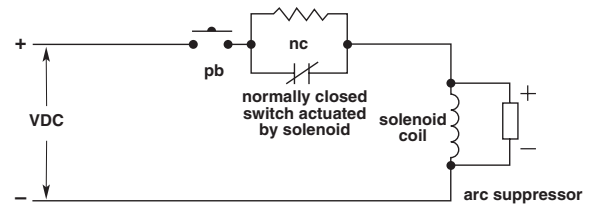

### Capacitor Hold-in Resistor Circuit

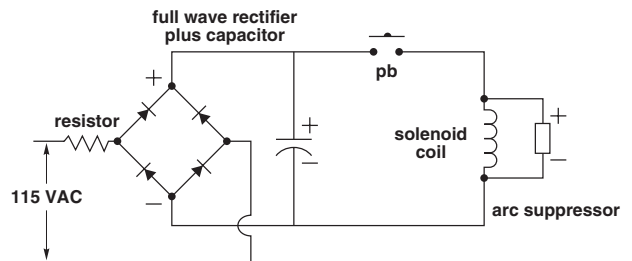

### Transistorised Hold-in Circuit

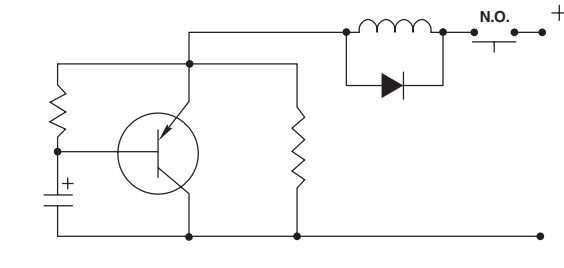

## Mechanical Hold-In Resistor Circuit

One of the more common methods to reduce coil current is a normally closed (NC) switch in parallel with a hold-in resistor. When push button (PB) closes the circuit, full voltage is impressed across the solenoid coil, bypassing the resistor through the NC switch. As the solenoid approaches the end of its stroke, a mechanical connection opens the NC contacts, inserting the resistor in series with the coil. This reduces the solenoid voltage to a point where the power input is high enough to allow the solenoid to hold in, and yet stay within its normal heat dissipating range.

## Capacitor Hold-In Resistor Circuit

In some cases, a switchless hold-in circuit may be used on 115 VAC applications. This consists of a capacitor which charges to a peak of approximately 150 volts. A resistor in the line ahead of the rectifier controls the hold-in current after the discharged capacitor has supplied the initial high stored energy.

## Transistorised Hold-In Circuit

As shown in the transistorised circuit on page H2, when the NO switch is closed, current flows through the base-collector while the capacitor is charging to input voltage. As the base-collector current flows, the emitter-collector circuit allows full power to be impressed across the solenoid coil. The transistor is switched off when the capacitor reaches full charge. Current flow is then through the hold-in resistor and solenoid coil at continuous duty power or less. When using this circuit, it is important that the transistor be on long enough to allow the solenoid to move the load through the complete stroke.

The graph on page L2 is a convenient guide to estimate hold-in resistor values. Because the actual value can vary according to the size of the load to be held, it should be used only as a starting point. Keep in mind that more hold-in current (lower resistance) is needed as the hold-in load increases. To use the graph, locate the coil resistance on the horizontal scale, then read the approximate hold-in resistor value on the vertical scale.

## Temperature and Force/Torque Resistance

The force/torque curves and coil data in this catalogue are based on the coil being at an ambient temperature of 20°C, and the use of a heat sink comparable to that called out in the notes below each table. When a solenoid is energised, the coil temperature rises. Since resistance varies with temperature, an increase in temperature produces a proportional increase in resistance. Increased resistance reduces the current flow when constant voltage is applied, and decreases the effective ampere turns and torque/force output. For each degree above or below 20°C, the resistance of the coil's copper wire changes by 0.393 percent per degree. A coil temperature rise of 80°C, for example, will increase the coil resistance by a factor of 0.514, which is equal to 80°C x 0.00393/°C. Calculation of resistance at any other temperature ( $t_2$ ) can be made using the following formula:

$$R_{t_2} = R_{20^\circ C} [1 + 0.00393 (t_2 - 20)]$$

Rearrangement of the formula produces a ratio between  $R_{20^\circ C}$  and  $R_{t_2}$  as follows:

$$\frac{R_{t_2}}{R_{20^\circ C}} = 1 + .00393 (t_2 - 20) = \text{Resistance Factor (R.F.)}$$

The Resistance Factor of copper wire at temperatures from -60°C (-76°F) to 260°C (500°F) is graphed below.

Once the actual coil temperature (ambient plus rise) is determined, the resistance factor can be determined as follows:

A size 3E, 31 awg coil has a resistance of 31.8 ohms at 20°C. After operating for a prolonged period at 10% duty, the approximate coil rise is 80°C. Added to 20°C, the coil temperature is 100°C. The Resistance Factor graph indicates a 1.5 factor (point where 100°C and diagonal intersect). At 100°C, the resistance of the 31.8 ohm coil is increased by this factor. With a constant voltage applied, the power decrease is proportional to the resistance increase ( $P = E^2/R$ ). The 10% duty power of a size 3 solenoid is 90 watts (at 20°C). The decrease in power at the elevated temperature is calculated by:

$$\frac{90 \text{ (Power at } 20^\circ\text{C)}}{1.3 \text{ (Resistance Factor)}} = 69 \text{ W}$$

By interpolating between the 25% and 10% duty cycle curves, the reduction in force due to the 80°C rise can be estimated for a given stroke.

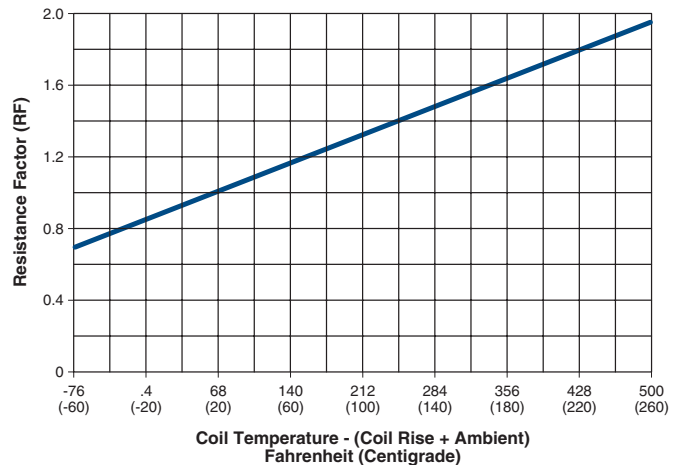

# Technical Data

## How to Simulate a Coil Wire Size

If you have a stock model Ledex solenoid, you can simulate performance with a different wire gage by changing the input voltage. A rule of thumb is that, as each wire size changes from one gage to the next, the voltage increases or decreases by the cube root of 2, or a factor of 1.26.

Coil data charts in this catalogue are tabulated with voltage values which provide essentially constant ampere turns for each wire size at given duty cycles. A stock model solenoid with a given coil awg can be used to simulate other wire gages under different voltage conditions as follows:

Assume you have a 12-volt power supply and you want to experiment with a size 3 low profile solenoid at continuous duty. In the size 3 coil chart, the closest continuous duty coil is 30 awg (15 volts). You can simulate the exact conditions you would have with a 30 awg coil and a 12 volt input by using a stock model with (1) a 28 awg coil, or (2) a 33 awg coil.

(1) The size 3, 28 awg coil is rated at 8.4 volts, continuous duty. The desired 30 awg coil is 2 gages higher.

$$\frac{12 \text{ (your voltage)}}{1.26^2} = 7.5$$

(factor for two awg. changes)

7.5 = voltage to simulate 30 awg coil at 12 volts when using stock model size 3 with 28 awg coil.

(2) The 33 awg is rated at 26 volts, continuous duty. The desired 30 awg is three gages lower.

$$12 \text{ volts} \times 1.26^3 = 24$$

24 = voltage to simulate 30 awg coil at 12 volts when using stock model size 3 with 33 awg coil.

## Input Power and Ohm's Law for Direct Current

To understand the relationships of power, current, voltage and resistance, use the chart below.

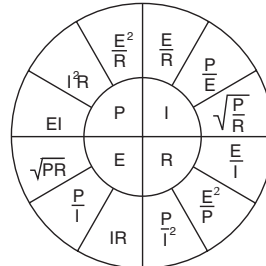

P = Power (watts)  
I = Current (amperes)  
E = Electromotive force (volts)  
R = Resistance (ohms)

## Environmental Considerations

Factors which impact the operation and performance of solenoids include:

- Temperature
  - Sand and dust
  - Humidity
  - Shock and vibration
  - Altitude, vacuum and pressure
  - Specific application considerations such as paper dust and exposure to certain chemicals
- Please consult an application engineer, if any of these factors are prominent in your planned solenoid design.



ERMEC, S.L. BARCELONA  
C/ Francesc Teixidó, 22  
E-08918 Badalona  
(Spain)

Tel.: (+34) 902 450 160  
Fax: (+34) 902 433 088  
[ermec@ermec.org](mailto:ermec@ermec.org)  
[www.ermec.org](http://www.ermec.org)

ERMEC, S.L. MADRID  
C/ Sagasta, 8, 1ª planta  
E-28004 Madrid  
(Spain)

PORTUGAL  
[portugal@ermec.com](mailto:portugal@ermec.com)

# Technical Glossary of Terms

## Air Gap

The air space between the armature hub and the base or the air space between the stationary and the moveable pole piece.

## Ampere Turns

The absolute value of magnetic flux determined by the number of copper wire turns in the coil and the magnitude of the current. Permissible temperature rise of the coil limits the magnitude of the power input. Heat makes the coil less efficient because it reduces the ampere turns and hence the flux density and the torque or force output

## Anchor Plate

The thin formed sheet metal plate fitted over the mounting studs on the base of rotary solenoids to provide containment for the return spring. It has tabs formed up around the circumference which are used to attach the end of the spring and allow adjustment.

## Armature Assembly

The assembly consisting of the armature plate, the hub, and the shaft which is the complete moving element in a rotary solenoid.

## Armature Plate

The large diameter plate which forms the main rotating element of the solenoid and contains the ball races which convert linear to rotary motion. Made from SAE #1008 or 1010 CRS and case hardened for wearability in the ball races.

## Axial Stroke

The amount of longitudinal movement the armature assembly travels as it rotates through its stroke. Value range from 0.022 to 0.100 inches depending on solenoid size and length of stroke.

## B-H Curve

The graph of the ratio of flux density to magnetic field intensity. The magnetic field intensity is usually plotted logarithmically.

## Bearing Balls

Precision stainless steel balls used in rotary solenoid ball races to provide essentially friction free rotary movement between the armature plate and the case.

## Bobbins

Most bobbins are made of nylon 6/6 and meet UL file #E-41938 or E-39806B.

## Bobbin Wound Coil

A coil, usually random wound on a spool which maintains the form and shape of the coil and also provides the coil insulation.

## Case

The outer shell and main component of the solenoid coil housing. Made of CRS #1008, #1010, 12L14 or 1215 case hardened to 513 on the Vickers scale (RC50) for sizes 0 to 6 (sizes 7 and 8 are not case hardened). The case has the three coined ball races, and is formed from flat stock drawn into a cup (size 7 is machined from bar stock and size 8 is made from tubing stock because of their size and thickness).

## Coil

Copper windings providing the electrical element of the solenoid through which current is passed to generate a magnetic field. Coils may be precision wound which allows the maximum amount of copper in the space provided or random wound or bobbin wound.

## Coil Arc Suppression

The application of electronic protection devices across switch contacts and coils to reduce the arc caused by interrupting the current flow through an inductive device such as a solenoid. Appropriate coil suppression greatly reduces this arcing.

## Coil Resistance

Coil resistance is the property of the coil which impedes the flow of current through it when a voltage is applied. Resistance values are shown in ohms for each solenoid wire awg for a temperature of 20°C. A resistance conversion factor may be used to determine what the resistance would be at other temperatures. This is particularly helpful in determining the effects of temperature on output torque or force. Use the resistance factor chart on page L8 or refer to the Temperature and Force/Torque Resistance section on page L3 for further calculation of resistance at temperatures other than 20°C.

## Coining

The process of striking the armature plate or case to form the three ball races on rotary solenoids. This process provides an extremely smooth, mirror-like surface in the ball races.

## Dielectric

Dielectric is the resistance between the coil and the case. Minimum dielectric value is 500 VRMS and range up to 1,500 VRMS depending on the solenoid size type and wire gage. Dielectric values are shown for each solenoid in the specifications chart.

## Dust Cover

A protective sheet metal cover pressed over the armature plate end of the rotary solenoid to protect the armature and bearing balls from dirt and other contaminants.

## Duty Cycle

ON Time/ON+OFF Time = Duty Cycle. Standard duty cycles used in this catalogue are 100%, 50%, 25%, 10% and 5%. Other values can be determined by interpolation between any two columns.

## Elongated Coils

These coils are 16% longer than standard precision wound rotary solenoid coils, and provide 30% more copper. These units will provide approximately the same torque with less wattage. If the same wattage as the standard precision coils is used, they will provide slightly more torque.

## Ending Torque

Torque that a rotary solenoid develops in the last degree or two of stroke.

# Technical Glossary of Terms

## End Play

The amount of free axial movement built into a rotary solenoid in the completely de-energised position. This axial movement, normally only a few thousandths of an inch, assures that the solenoid is capable of returning to the completely de-energised position and does not stop before the balls reach the end of their races.

## Flux Density

The number of Webers per square metre in a cross section normal to the direction of the flux. This quantity is known as Tesla and given the symbol B. The typical knee in the B-H curve where iron becomes difficult to further magnetise is around 1.6 Tesla.

## Flux, Magnetic

The physical manifestation of a condition existing in a medium or material subjected to a magnetizing influence. The quantity is characterised by the fact that an electromotive force is induced in a conductor surrounding the flux during any time there is a change in flux magnitude. A unit of flux is a Weber which is defined as that which being linearly attenuated to zero in 1 second, induces in a surrounding turn, an EMF of 1 volt.

## Gross Torque

The starting torque available from a rotary solenoid before subtracting the nominal return spring torque.

## Heat Rise

The rise in temperature which results from operating the solenoid at the predetermined conditions established in the coil data charts, with the specified heat sink. Standard solenoids will have a temperature rise of 80°C over ambient.

## Heat Sink

The maximum allowable watts for each solenoid are based on an unrestricted flow of air at 20°C with the solenoid mounted on the equivalent heat sink specified for each size. Inadequate heat sink or restricted air flow may result in overheating of the solenoid.

## Holding Torque

The torque required to break the armature loose from the energised position while under power. Normally checked under continuous duty operation and after reaching the stabilised operating temperature.

## Hub

Part of the armature plate assembly which forms the moving pole face. Made of 12L14 or 1215 CRS. The shaft is pressed into the hub which is staked to the armature plate.

## Inductance

An electrical property of solenoids from which can be calculated the current rise time, the stored magnetic energy, the inductive reactance and the impedance. Inductance is an electrical energy storage unit (analogous to capacitance) and is measured in henrys.

## Lead Wires

Standard temperature rated coils use PVC insulated stranded lead wire, UL style 1007 rated for 80°C at 300 volts. It also meets CSA type TR-64, 90°C at 600 volts; and MIL-W-16878/2, 105°C at 1000 volts. High temperature coils use Teflon Type E, TFE, and meets MIL-W-16878/4A rated at 200°C at 600 volts.

## Lubricant

Standard rotary solenoids are lubricated in the ball races and in the sleeve bearing with Nye Rheolube #719L, a lithium soap-based synthetic hydrocarbon grease with wide temperature capabilities from -54°C to over 95°C. The base oil is compatible with most ester-vulnerable plastics and elastomers. It contains a rust inhibitor and an ultraviolet sensitive dye. Endurance engineered solenoids are lubricated with Shell Alvania #2 which is also a lithium soap-based grease with a temperature range of -29°C to 121°C.

## Magnet Wire

100% copper wire, UL-recognised, single film insulation rated at 200°C (NEMA MW 35C) or 155°C (NEMA MW 80C).

## Magnetic Field Intensity

The closed loop integral of this quantity is equal to the total current enclosed, as defined by Maxwell's equation. Or, the magnetomotive force per unit length in a magnetic circuit. This quantity is given the symbol H.

## Magnetomotive Force

See ampere turns.

## Needle Bearing

A bearing used in long life rotary solenoids which is a circle of long needles forming the bearing surface for the shaft.

## Net Torque

The starting torque available from the solenoid after subtracting the nominal return spring torque.

## PWM

### (Pulse Width Modulation)

If a solenoid is controlled by a transistor which is signaled from a microprocessor, the PWM can be considered as an alternate means for reducing sizes or saving energy. PWM reduces the effective voltage by pulsing the voltage input. For example, if a solenoid has 12 volts supplied, but at 500 Hz at a 50% duty, the solenoid acts exactly as if it is connected to a 6-volt supply. If the duty cycle is changed to 25%, then the solenoid performs like one hooked to a 3-volt supply. The frequency must be higher than the solenoid can respond to otherwise chatter or humming will occur. Due to the inductive nature of the solenoid coil, the current is smoothed resulting in a constant force. Initially, the microprocessor must leave the transistor on long enough to allow the solenoid to energise. After that point, the microprocessor must alternately issue ON and OFF pulses to the transistor to achieve the appropriate duty cycle.

# Technical Glossary of Terms

## Permeability

The ratio of flux density in a given medium to the magnetic field intensity. The symbol used is  $\mu$  and has the value of  $4\pi E-7$  in a vacuum.

## Permeance

The ratio of the flux through any given cross section of a given medium (bounded by equipotential surfaces) to the difference in magnetomotive force between the two surfaces.

## Plunger

The magnetic moving component of a linear solenoid, typically made from cold, rolled steel.

## Precision Wound Coil

A coil whose individual turns have a prescribed pattern which they must follow during the winding process whereby each turn is laid precisely next to the previous turn. This process allows for the maximum amount of copper in the allotted space. Normally carries a  $\pm 5\%$  tolerance on coil resistance.

## Random Wound Coil

A coil whose turns are allowed to wind randomly in no specific pattern. One turn may overlap another or may lay side by side or even spiral completely across the surface of the coil. Normally carries a  $\pm 10\%$  tolerance on resistance

## Relative Permeability

The ratio of the flux density in a given medium to that which would be produced in a vacuum with the same magnetizing force. Non-magnetic materials, including air, have a relative permeability of 1, while magnetic materials such as iron, have initial relative permeabilities of around 2,000.

## Residual Magnetism

The magnetism which remains in effect on a piece of magnetic material or between two pieces of magnetic material after the electromagnetic field created by the coil has been removed. An air gap is usually maintained between two magnetic poles to minimise the effects of residual magnetism.

## Resistance Tolerance

Coil resistance tolerances are generally  $\pm 5\%$  for heavier gage wires where precision coil windings are used and  $\pm 10\%$  for finer gage wire where random winding processes are used. Tolerances are shown for each solenoid in the individual specification charts.

## Return Springs

All standard stock rotary solenoids have scroll type return springs. Values range from 1 oz-in to 1 lb-in depending on the solenoid size. Tolerance on springs are  $\pm 20\%$  of the nominal value shown. Return springs are an available feature on any solenoid.

## Safety Factor

The ambient temperature range, voltage fluctuation, return springs and temperature rise all affect the net available output torque or force of a solenoid. A 1.5 safety factor should be applied to preliminary calculations of torque or force.

## Shaft—Other Solenoids

The main axle of the solenoid which runs from the armature through the base and out the bottom and provides the main bearing. The shaft is also used for external attachment to the solenoid. Normally made of non-magnetic #303 stainless steel. On long-life rotary solenoid models the shaft is made of CRS #12L14 or 1215 which has been case hardened in the bearing area for wear resistance.

## Shaft—Tubular Solenoid

The small diameter portion of the plunger assembly of a push-type tubular solenoid which protrudes through the base or stationary pole face and provides push capability; usually made from #303 stainless steel.

## Sleeve Bearing

The cylindrical bearing in the base of the solenoid which provides a guide for the shaft. Usually made from phosphor bronze, it can be made of other materials for different applications requiring longer life.

## Sleeving

Sleeving used on standard solenoids to insulate the lead wires where they exit the solenoid case is black Vinylite per Mil-I-631B, Type F, subform Ua, Grade C, Class 1, Category 1, and meets UL file #E13565 and E-18459. Sleeving on high temperature coils is Teflon for temperatures up to 200°C continuous and will meet the requirements of AMS 3655 and UL file #E-20344 and E-39513.

## Starting Torque

The torque which is produced by a rotary solenoid in the first degree or two of stroke from the de-energised position.

## Stator Assembly

That portion of any solenoid which contains the coil, case and base. This portion remains stationary during operation.

## Tape

Coil wrapping tape is clear Mylar brand polyester film 0.002" thick which has been slit to the desired width and is used to wrap the coil in an overlapping manner. The film is per Mil-I-631 Type G, Form T<sub>p</sub>, Class I, rated for 130°C continuous and meets UL file #E-39505. Coil banding tape is Mylar polyester film, adhesive backed per Mil-I-15126 Type MFT. This tape is used to wrap around the O.D. of the coil one thickness of 0.0025".

**ERMEC**

División Relojería Monumental

ERMEC, S.L. BARCELONA  
C/ Francesc Teixidó, 22  
E-08918 Badalona  
(Spain)

Tel.: (+34) 902 450 160  
Fax: (+34) 902 433 088  
[ermec@ermec.org](mailto:ermec@ermec.org)  
[www.ermec.org](http://www.ermec.org)

ERMEC, S.L. MADRID  
C/ Sagasta, 8, 1ª planta  
E-28004 Madrid  
(Spain)

PORTUGAL  
[portugal@ermec.com](mailto:portugal@ermec.com)

# Technical Copper Resistance Factors

Because the resistance of copper wire varies with temperature, a given resistance must be compensated for when it is measured at some other temperature. The chart below can be used to determine the resistance at

different temperatures or the temperature if the resistance is known. (See Temperature and Force/Resistance Factor on page L3 for Resistance calculations.)

°C	°F	R.F.	°C	°F	R.F.	°C	°F	R.F.	°C	°F	R.F.
-55	-67.0	0.70525	0	32.0	0.92140	60	140.0	1.15720	120	248.0	1.39300
-54	-65.2	0.70918	1	33.8	0.92533	61	141.8	1.16113	121	249.8	1.39693
-53	-63.4	0.71311	2	35.6	0.92926	62	143.6	1.16506	122	251.6	1.40086
-52	-61.6	0.71704	3	37.4	0.93319	63	145.4	1.16899	123	253.4	1.40479
-51	-59.8	0.72097	4	39.2	0.93712	64	147.2	1.17292	124	255.2	1.40872
-50	-58.0	0.72490	5	41.0	0.94105	65	149.0	1.17685	125	257.0	1.41265
-49	-56.2	0.72883	6	42.8	0.94498	66	150.8	1.18078	126	258.8	1.41658
-48	-54.4	0.73276	7	44.6	0.94891	67	152.6	1.18471	127	260.6	1.42051
-47	-52.6	0.73669	8	46.4	0.95284	68	154.4	1.18864	128	262.4	1.42444
-46	-50.8	0.74062	9	48.2	0.95677	69	156.2	1.19257	129	264.2	1.42837
-45	-49.0	0.74455	10	50.0	0.96070	70	158.0	1.19650	130	266.0	1.43230
-44	-47.2	0.74848	11	51.8	0.96463	71	159.8	1.20043	131	267.8	1.43623
-43	-45.4	0.75241	12	53.6	0.96856	72	161.6	1.20436	132	269.6	1.44016
-42	-43.6	0.75634	13	55.4	0.97249	73	163.4	1.20829	133	271.4	1.44409
-41	-41.8	0.76027	14	57.2	0.97642	74	165.2	1.21222	134	273.2	1.44802
-40	-40.0	0.76420	15	59.0	0.98035	75	167.0	1.21615	135	275.0	1.45195
-39	-38.2	0.76813	16	60.8	0.98428	76	168.8	1.22008	136	276.8	1.45588
-38	-36.4	0.77206	17	62.6	0.98821	77	170.6	1.22401	137	278.6	1.45981
-37	-34.6	0.77599	18	64.4	0.99214	78	172.4	1.22794	138	280.4	1.46374
-36	-32.8	0.77992	19	66.2	0.99607	79	174.2	1.23187	139	282.2	1.46767
-35	-31.0	0.78385	20	68.0	1.00000	80	176.0	1.23580	140	284.0	1.47160
-34	-29.2	0.78778	21	69.8	1.00393	81	177.8	1.23973	141	285.8	1.47553
-33	-27.4	0.79171	22	71.6	1.00786	82	179.6	1.24366	142	287.6	1.47946
-32	-25.6	0.79564	23	73.4	1.01179	83	181.4	1.24759	143	289.4	1.48339
-31	-23.8	0.79957	24	75.2	1.01572	84	183.2	1.25152	144	291.2	1.48732
-30	-22.0	0.80350	25	77.0	1.01965	85	185.0	1.25545	145	293.0	1.49125
-29	-20.2	0.80743	26	78.8	1.02358	86	186.8	1.25938	146	294.8	1.49518
-28	-18.4	0.81136	27	80.6	1.02751	87	188.6	1.26331	147	296.6	1.49911
-27	-16.6	0.81529	28	82.4	1.03144	88	190.4	1.26724	148	298.4	1.50304
-26	-14.8	0.81922	29	84.2	1.03537	89	192.2	1.27117	149	300.2	1.50697
-25	-13.0	0.82315	30	86.0	1.03930	90	194.0	1.27510	150	302.0	1.51090
-24	-11.2	0.82708	31	87.8	1.04323	91	195.8	1.27903	151	303.8	1.51483
-23	-9.4	0.83101	32	89.6	1.04716	92	197.6	1.28296	152	305.6	1.51876
-22	-7.6	0.83494	33	91.4	1.05109	93	199.4	1.28689	153	307.4	1.52269
-21	-5.8	0.83887	34	93.2	1.05502	94	201.2	1.29082	154	309.2	1.52662
-20	-4.0	0.84280	35	95.0	1.05895	95	203.0	1.29475	155	311.0	1.53055
-19	-2.2	0.84673	36	96.8	1.06288	96	204.8	1.29868	156	312.8	1.53448
-18	-0.4	0.85066	37	98.6	1.06681	97	206.6	1.30261	157	314.6	1.53841
-17	1.4	0.85459	38	100.4	1.07074	98	208.4	1.30654	158	316.4	1.54234
-16	3.2	0.85852	39	102.2	1.07467	99	210.2	1.31047	159	318.2	1.54627
-15	5.0	0.86245	40	104.0	1.07860	100	212.0	1.31440	160	320.0	1.55020
-14	6.8	0.86638	41	105.8	1.08253	101	213.8	1.31833	161	321.8	1.55413
-13	8.6	0.87031	42	107.6	1.08646	102	215.6	1.32226	162	323.6	1.55806
-12	10.4	0.87424	43	109.4	1.09039	103	217.4	1.32619	163	325.4	1.56199
-11	12.2	0.87817	44	111.2	1.09432	104	219.2	1.33012	164	327.2	1.56592
-10	14.0	0.88210	45	113.0	1.09825	105	221.0	1.33405	165	329.0	1.56985
-9	15.8	0.88603	46	114.8	1.10218	106	222.8	1.33798	166	330.8	1.57378
-8	17.6	0.88996	47	116.6	1.10611	107	224.6	1.34191	167	332.6	1.57771
-7	19.4	0.89389	48	118.4	1.11004	108	226.4	1.34584	168	334.4	1.58164
-6	21.2	0.89782	49	120.2	1.11397	109	228.2	1.34977	169	336.2	1.58557
-5	23.0	0.90175	50	122.0	1.11790	110	230.0	1.35370	170	338.0	1.58950
-4	24.8	0.90568	51	123.8	1.12183	111	231.8	1.35763	171	339.8	1.59343
-3	26.6	0.90960	52	125.6	1.12576	112	233.6	1.36156	172	341.6	1.59736
-2	28.4	0.91354	53	127.4	1.12969	113	235.4	1.36549	173	343.4	1.60129
-1	30.2	0.91747	54	129.2	1.13362	114	237.2	1.36942	174	345.2	1.60522
			55	131.0	1.13755	115	239.0	1.37335	175	347.0	1.60915
			56	132.8	1.14148	116	240.8	1.37728	176	348.8	1.61308
			57	134.6	1.14541	117	242.6	1.38121	177	350.6	1.61701
			58	136.4	1.14934	118	244.4	1.38514	178	352.4	1.62094
			59	138.2	1.15327	119	246.2	1.38907	179	354.2	1.62487

# Preferred Range\*

Part Number	Product	Model/Size	Page	Part Number	Product	Model/Size	Page	
Ultimag	4EM	199172-007	B7	Low Profile	1ECM	282342-031	G6	
	5EM	199173-025	B8		2EFM	282343-030	G7	
	6EM	199174-023	B9		2ECM	282344-030	G7	
BTA	2EVM	195927-030	C5		3EFM	282345-028	G8	
	3EVM	195928-029	C6		3ECM	282346-028	G8	
	4EVM	195929-027	C7		4EFM	282347-026	G9	
	5EVM	195930-025	C8		4ECM	282348-026	G9	
	6EVM	195931-023	C9		5SFM	282349-024	G10	
Rotary Solenoid	1E	M-15218-030	D10		5ECM	282350-024	G11	
	2E	M-2994-028	D12		6SFM	282351-023	G12	
	3B	910-228-326	D14		6ECM	282352-023	G13	
	3E	M-2616-027	D16		Open Frame	B4HDM-255-M-36	B4HDM	H4
	4E	M-15237-025	D18			B11M-255-M-36	B11M	H7
	5B	910-282-523	D20	B16M-255-B-1		B16M	H10	
	5S	M-3397-023	D22	B17M-255-A-1		B167M	H12	
	6S	M-15064-023	D24	B22M-255-M-36		B22M	H16	
7S	M-15614-023	D26	B41M-255-B-1	B41M		H19		
Soft Shift	2EPM	196655-030	E5	C8M-273-M-36		C8M	H23	
	3EPM	196656-028	E6	C9M-273-M-36		C9M	H24	
	4EPM	196657-026	E7	C15M-273-M-36	C15M	H25		
	5EPM	196658-024	E8	C26M-273-M-36	C26M	H26		
	6EPM	196659-023	E9	C33M-273-M-36	C33M	H27		
	Tubular	13 x 27 Pull	195222-232	F12	C34M-273-M-36	C34M	H28	
13 x 27 Pull		195222-132	F12					
13 x 27 Push		195223-232	F14					
13 x 27 Push		195223-132	F14					
20 x 40 Pull		195224-229	F16					
20 x 40 Pull		195224-129	F16					
20 x 40 Push		195225-229	F18					
20 x 40 Push		195225-129	F18					
26 x 52 Pull		195224-229	F20					
26 x 52 Pull		195224-129	F20					
26 x 52 Push		195225-229	F22					
26 x 52 Push		195225-129	F22					
125M		282366-024	F24					
150M		282367-023	F25					



**ERMEC, S.L. BARCELONA**  
 C/ Francesc Teixidó, 22  
 E-08918 Badalona  
 (Spain)

Tel.: (+34) 902 450 160  
 Fax: (+34) 902 433 088  
[ermec@ermec.org](mailto:ermec@ermec.org)  
[www.ermec.org](http://www.ermec.org)

**ERMEC, S.L. MADRID**  
 C/ Sagasta, 8, 1ª planta  
 E-28004 Madrid  
 (Spain)

**PORTUGAL**  
[portugal@ermec.com](mailto:portugal@ermec.com)

\*Parts typically found in distribution or in factory stock.

# Index of Part Numbers

121011-001	Quick Connect Rectifier	K5	910-284-5XX	Rotary 5B	D20
122654-001	Diode/Capacitor	K3	910-285-3XX	Rotary 3B	D14
122655-001	Diode/Capacitor	K3	910-285-5XX	Rotary 5B	D20
126911-001	Diode/Capacitor	K3	910-286-3XX	Rotary 3B	D14
126913-001	Diode/Capacitor	K3	910-286-5XX	Rotary 5B	D20
151094-XXX	Tubular-Latch 13 x 16 Pull	F8	910-287-3XX	Rotary 3B	D14
152160-001	Hold-In Module	K6	910-287-5XX	Rotary 5B	D20
187478-001	Hold-In Circuit Module	K6	910-288-3XX	Rotary 3B	D14
190805-001	Diode/Capacitor	K3	910-288-5XX	Rotary 5B	D20
190910-001	Diode/Capacitor	K3	910-289-5XX	Rotary 5B	D20
195220-XXX	Tubular 13 x 14 Pull	F6	910-360-3XX	Rotary 3B	D14
195221-XXX	Tubular 13 x 14 Push	F10	910-360-5XX	Rotary 5B	D20
195222-XXX	Tubular 13 x 27 Pull	F12	910-361-3XX	Rotary 3B	D14
195223-XXX	Tubular 13 x 27 Push	F14	910-361-5XX	Rotary 5B	D20
195224-XXX	Tubular 20 x 40 Pull	F16	910-362-3XX	Rotary 3B	D14
195225-XXX	Tubular 20 x 40 Push	F18	910-362-5XX	Rotary 5B	D20
195226-XXX	Tubular 26 x 52 Pull	F20	910-363-3XX	Rotary 3B	D14
195227-XXX	Tubular 26 x 52 Push	F22	910-363-5XX	Rotary 5B	D20
195927-0XX	BTA 2EVM	B5	910-364-5XX	Rotary 5B	D20
195928-0XX	BTA 3EVM	B6	910-365-3XX	Rotary 3B	D14
195929-0XX	BTA 4EVM	B7	910-365-5XX	Rotary 5B	D20
195930-0XX	BTA 5EVM	B8	910-366-3XX	Rotary 3B	D14
195931-0XX	BTA 6EVM	B9	910-366-5XX	Rotary 5B	D20
195936-0XX	BTA 2EVM	B5	910-367-3XX	Rotary 3B	D14
195937-0XX	BTA 3EVM	B6	910-367-5XX	Rotary 5B	D20
195938-0XX	BTA 4EVM	B7	910-368-3XX	Rotary 3B	D14
195939-0XX	BTA 5EVM	B8	910-368-5XX	Rotary 5B	D20
195940-0XX	BTA 6EVM	B9	910-369-5XX	Rotary 5B	D20
196655-0XX	Soft Shift 2EPM	E5	910-380-3XX	Rotary 3B	D14
196656-0XX	Soft Shift 3EPM	E6	910-380-5XX	Rotary 5B	D20
196657-0XX	Soft Shift 4EPM	E7	910-381-3XX	Rotary 3B	D14
196658-0XX	Soft Shift 5EPM	E8	910-381-5XX	Rotary 5B	D20
196659-0XX	Soft Shift 6EPM	E9	910-382-3XX	Rotary 3B	D14
196675-0XX	Tubular Size 175M Pull	F26	910-382-5XX	Rotary 5B	D20
199172-0XX	Ultimag 4EM	A4	910-383-3XX	Rotary 3B	D14
199173-0XX	Ultimag 5EM	A6	910-383-5XX	Rotary 5B	D20
199174-0XX	Ultimag 6EM	A8	910-384-5XX	Rotary 5B	D20
282340-0XX	Low Profile 0ECM	G5	910-385-3XX	Rotary 3B	D14
282342-0XX	Low Profile 1ECM	G6	910-385-5XX	Rotary 5B	D20
282343-0XX	Low Profile 2EFM	G7	910-386-3XX	Rotary 3B	D14
282344-0XX	Low Profile 2ECM	G7	910-386-5XX	Rotary 5B	D20
282345-0XX	Low Profile 3EFM	G8	910-387-3XX	Rotary 3B	D14
282346-0XX	Low Profile 3ECM	G8	910-387-5XX	Rotary 5B	D20
282347-0XX	Low Profile 4EFM	G9	910-388-3XX	Rotary 3B	D14
282348-0XX	Low Profile 4ECM	G9	910-388-5XX	Rotary 5B	D20
282349-0XX	Low Profile 5SFM	G10	910-389-5XX	Rotary 5B	D20
282350-0XX	Low Profile 5ECM	G11	910-490-3XX	Rotary 3B	D14
282351-0XX	Low Profile 6SFM	G12	910-490-5XX	Rotary 5B	D20
282352-0XX	Low Profile 6ECM	G13	910-491-3XX	Rotary 3B	D14
282354-0XX	Low Profile 7ECM	G14	910-491-5XX	Rotary 5B	D20
282356-0XX	Low Profile 8ECM	G15	910-492-3XX	Rotary 3B	D14
282366-0XX	Tubular Size 125M Pull	F24	910-492-5XX	Rotary 5B	D20
282367-0XX	Tubular Size 150M Pull	F25	910-493-3XX	Rotary 3B	D14
910-280-3XX	Rotary 3B	D14	910-493-5XX	Rotary 5B	D20
910-280-5XX	Rotary 5B	D20	910-494-5XX	Rotary 5B	D20
910-281-3XX	Rotary 3B	D14	910-495-3XX	Rotary 3B	D14
910-281-5XX	Rotary 5B	D20	910-495-5XX	Rotary 5B	D20
910-282-3XX	Rotary 3B	D14	910-496-3XX	Rotary 3B	D14
910-282-5XX	Rotary 5B	D20	910-496-5XX	Rotary 5B	D20
910-283-3XX	Rotary 3B	D14	910-497-3XX	Rotary 3B	D14
910-283-5XX	Rotary 5B	D20	910-497-5XX	Rotary 5B	D20

# Index of Part Numbers

910-498-3XX	Rotary 3B	D14	B17M-L-155-B-3	Box Frame-Latch, DC Operation	H13
910-498-5XX	Rotary 5B	D20	B17M-L-156-B-3	Box Frame-Latch, DC Operation	H13
910-499-5XX	Rotary 5B	D20	B17M-L-158-B-3	Box Frame-Latch, DC Operation	H13
910-640-3XX	Rotary 3B	D14	B20M-251-A-3	Box Frame, DC Operation	H14
910-640-5XX	Rotary 5B	D20	B20M-252-A-3	Box Frame, DC Operation	H14
910-641-3XX	Rotary 3B	D14	B20M-253-A-3	Box Frame, DC Operation	H14
910-641-5XX	Rotary 5B	D20	B20M-254-A-3	Box Frame, DC Operation	H14
910-642-3XX	Rotary 3B	D14	B20M-255-A-3	Box Frame, DC Operation	H14
910-642-5XX	Rotary 5B	D20	B21M-251-A-3	Box Frame, DC Operation	H15
910-643-3XX	Rotary 3B	D14	B21M-252-A-3	Box Frame, DC Operation	H15
910-643-5XX	Rotary 5B	D20	B21M-253-A-3	Box Frame, DC Operation	H15
910-644-5XX	Rotary 5B	D20	B21M-254-A-3	Box Frame, DC Operation	H15
910-645-3XX	Rotary 3B	D14	B21M-255-A-3	Box Frame, DC Operation	H15
910-645-5XX	Rotary 5B	D20	B22M-251-M-36	Box Frame, DC Operation	H16
910-646-3XX	Rotary 3B	D14	B22M-252-M-36	Box Frame, DC Operation	H16
910-646-5XX	Rotary 5B	D20	B22M-253-M-36	Box Frame, DC Operation	H16
910-647-3XX	Rotary 3B	D14	B22M-254-M-36	Box Frame, DC Operation	H16
910-647-5XX	Rotary 5B	D20	B22M-255-M-36	Box Frame, DC Operation	H16
910-648-3XX	Rotary 3B	D14	B22M-L-X51-M-36	Box Frame-Latch, DC Operation	H17
910-648-5XX	Rotary 5B	D20	B22M-L-X52-M-36	Box Frame-Latch, DC Operation	H17
910-649-5XX	Rotary 5B	D20	B22M-L-X53-M-36	Box Frame-Latch, DC Operation	H17
A-46502-003	Octal Plug-In Rectifier	K5	B22M-L-X54-M-36	Box Frame-Latch, DC Operation	H17
B4HDM-251-M-36	Box Frame, DC Operation	H6	B22M-L-X55-M-36	Box Frame-Latch, DC Operation	H17
B4HDM-252-M-36	Box Frame, DC Operation	H6	B27M-251-A-3	Box Frame, DC Operation	H18
B4HDM-253-M-36	Box Frame, DC Operation	H6	B27M-252-A-3	Box Frame, DC Operation	H18
B4HDM-254-M-36	Box Frame, DC Operation	H6	B27M-253-A-3	Box Frame, DC Operation	H18
B4HDM-255-M-36	Box Frame, DC Operation	H6	B27M-254-A-3	Box Frame, DC Operation	H18
B11M-251-M-36	Box Frame, DC Operation	H7	B27M-255-A-3	Box Frame, DC Operation	H18
B11M-252-M-36	Box Frame, DC Operation	H7	B41M-251-B-1	Box Frame, DC Operation	H19
B11M-253-M-36	Box Frame, DC Operation	H7	B41M-252-B-1	Box Frame, DC Operation	H19
B11M-254-M-36	Box Frame, DC Operation	H7	B41M-253-B-1	Box Frame, DC Operation	H19
B11M-255-M-36	Box Frame, DC Operation	H7	B41M-254-B-1	Box Frame, DC Operation	H19
B14M-253-B-1	Box Frame, DC Operation	H8	B41M-255-B-1	Box Frame, DC Operation	H19
B14M-254-B-1	Box Frame, DC Operation	H8	B75M-252-B-1	Box Frame, DC Operation	H20
B14M-255-B-1	Box Frame, DC Operation	H8	B75M-253-B-1	Box Frame, DC Operation	H20
B14M-L-X53-B-4	Box Frame-Latch, DC Operation	H9	B75M-254-B-1	Box Frame, DC Operation	H20
B14M-L-X54-B-4	Box Frame-Latch, DC Operation	H9	B75M-255-B-1	Box Frame, DC Operation	H20
B14M-L-X55-B-4	Box Frame-Latch, DC Operation	H9	C5M-267-B-1	C Frame, DC Operation	H21
B14M-L-X56-B-4	Box Frame-Latch, DC Operation	H9	C5M-268-B-1	C Frame, DC Operation	H21
B14M-L-X58-B-4	Box Frame-Latch, DC Operation	H9	C5M-269-B-1	C Frame, DC Operation	H21
B16M-252-B-1	Box Frame, DC Operation	H10	C5M-270-B-1	C Frame, DC Operation	H21
B16M-253-B-1	Box Frame, DC Operation	H10	C5M-271-B-1	C Frame, DC Operation	H21
B16M-254-B-1	Box Frame, DC Operation	H10	C5M-272-B-1	C Frame, DC Operation	H21
B16M-255-B-1	Box Frame, DC Operation	H10	C5M-273-B-1	C Frame, DC Operation	H21
B16M-256-B-1	Box Frame, DC Operation	H10	C5M-L-267-B-1	C Frame, DC Operation	H22
B16M-258-B-1	Box Frame, DC Operation	H10	C5M-L-268-B-1	C Frame, DC Operation	H22
B16M-L-152-B-3	Box Frame-Latch, DC Operation	H11	C5M-L-269-B-1	C Frame, DC Operation	H22
B16M-L-153-B-3	Box Frame-Latch, DC Operation	H11	C5M-L-270-B-1	C Frame, DC Operation	H22
B16M-L-154-B-3	Box Frame-Latch, DC Operation	H11	C5M-L-271-B-1	C Frame, DC Operation	H22
B16M-L-155-B-3	Box Frame-Latch, DC Operation	H11	C5M-L-272-B-1	C Frame, DC Operation	H22
B16M-L-156-B-3	Box Frame-Latch, DC Operation	H11	C5M-L-273-B-1	C Frame, DC Operation	H22
B16M-L-158-B-3	Box Frame-Latch, DC Operation	H11	C8M-269-M-36	C Frame, DC Operation	H23
B17M-252-A-1	Box Frame, DC Operation	H12	C8M-270-M-36	C Frame, DC Operation	H23
B17M-253-A-1	Box Frame, DC Operation	H12	C8M-271-M-36	C Frame, DC Operation	H23
B17M-254-A-1	Box Frame, DC Operation	H12	C8M-272-M-36	C Frame, DC Operation	H23
B17M-255-A-1	Box Frame, DC Operation	H12	C8M-273-M-36	C Frame, DC Operation	H23
B17M-256-A-1	Box Frame, DC Operation	H12	C8M-274-M-36	C Frame, DC Operation	H23
B17M-258-A-1	Box Frame, DC Operation	H12	C8M-276-M-36	C Frame, DC Operation	H23
B17M-L-152-B-3	Box Frame-Latch, DC Operation	H13	C9M-269-M-36	C Frame, DC Operation	H24
B17M-L-153-B-3	Box Frame-Latch, DC Operation	H13	C9M-270-M-36	C Frame, DC Operation	H24
B17M-L-154-B-3	Box Frame-Latch, DC Operation	H13	C9M-271-M-36	C Frame, DC Operation	H24

# Index of Part Numbers

C9M-272-M-36	C Frame, DC Operation	H24	E-1291-0XX	Rotary 6S	D24
C9M-273-M-36	C Frame, DC Operation	H24	E-1294-0XX	Rotary 2E	D12
C15M-269-A-3	C Frame, DC Operation	H25	E-1305-0XX	Rotary 1E	D10
C15M-270-A-3	C Frame, DC Operation	H25	E-1306-0XX	Rotary 6S	D24
C15M-271-A-3	C Frame, DC Operation	H25	E-1308-0XX	Rotary 5S	D22
C15M-272-A-3	C Frame, DC Operation	H25	E-1309-0XX	Rotary 4E	D18
C15M-273-A-3	C Frame, DC Operation	H25	E-1310-0XX	Rotary 4E	D18
C26M-269-M-36	C Frame, DC Operation	H26	E-1311-0XX	Rotary 6S	D24
C26M-270-M-36	C Frame, DC Operation	H26	E-1312-0XX	Rotary 7S	D26
C26M-271-M-36	C Frame, DC Operation	H26	E-1317-0XX	Rotary 7S	D26
C26M-271-M-36	C Frame, DC Operation	H26	E-1344-0XX	Rotary 2E	D12
C26M-273-M-36	C Frame, DC Operation	H26	E-1345-0XX	Rotary 5S	D22
C33M-269-M-33	C Frame, DC Operation	H27	E-1352-0XX	Rotary 7S	D26
C33M-270-M-33	C Frame, DC Operation	H27	E-1354-0XX	Rotary 7S	D26
C33M-271-M-33	C Frame, DC Operation	H27	E-1355-0XX	Rotary 7S	D26
C33M-272-M-33	C Frame, DC Operation	H27	E-1356-0XX	Rotary 7S	D26
C33M-273-M-33	C Frame, DC Operation	H27	E-1423-0XX	Rotary 5S	D22
C34M-269-M-33	C Frame, DC Operation	H28	E-1428-0XX	Rotary 7S	D26
C34M-270-M-33	C Frame, DC Operation	H28	E-1431-0XX	Rotary 5S	D22
C34M-271-M-33	C Frame, DC Operation	H28	E-1467-0XX	Rotary 7S	D26
C34M-272-M-33	C Frame, DC Operation	H28	E-15000-0XX	Rotary 4E	D18
C34M-273-M-33	C Frame, DC Operation	H28	E-15001-0XX	Rotary 4E	D18
E-1002-0XX	Rotary 6S	D24	E-15004-0XX	Rotary 2E	D12
E-1005-0XX	Rotary 6S	D24	E-15005-0XX	Rotary 3E	D16
E-1024-0XX	Rotary 2E	D12	E-15009-0XX	Rotary 7S	D26
E-1075-0XX	Rotary 3E	D16	E-15011-0XX	Rotary 4E	D18
E-1079-0XX	Rotary 2E	D12	E-15013-0XX	Rotary 6S	D24
E-1082-0XX	Rotary 5S	D22	E-15014-0XX	Rotary 7S	D26
E-1087-0XX	Rotary 5S	D22	E-15015-0XX	Rotary 4E	D18
E-1088-0XX	Rotary 2E	D12	E-15016-0XX	Rotary 4E	D18
E-1094-0XX	Rotary 2E	D12	E-15020-0XX	Rotary 3E	D16
E-1112-0XX	Rotary 6S	D24	E-15023-0XX	Rotary 6S	D24
E-1125-0XX	Rotary 5S	D22	E-15024-0XX	Rotary 6S	D24
E-1132-0XX	Rotary 4E	D18	E-15036-0XX	Rotary 6S	D24
E-1135-0XX	Rotary 3E	D16	E-15039-0XX	Rotary 1E	D10
E-1140-0XX	Rotary 1E	D10	E-15046-0XX	Rotary 2E	D12
E-1141-0XX	Rotary 1E	D10	E-15054-0XX	Rotary 7S	D26
E-1142-0XX	Rotary 1E	D10	E-15064-0XX	Rotary 6S	D24
E-1143-0XX	Rotary 1E	D10	E-15066-0XX	Rotary 6S	D24
E-1144-0XX	Rotary 1E	D10	E-15067-0XX	Rotary 6S	D24
E-1145-0XX	Rotary 1E	D10	E-15072-0XX	Rotary 5S	D22
E-1146-0XX	Rotary 1E	D10	E-15076-0XX	Rotary 7S	D26
E-1147-0XX	Rotary 1E	D10	E-15080-0XX	Rotary 3E	D16
E-1148-0XX	Rotary 1E	D10	E-15084-0XX	Rotary 1E	D10
E-1149-0XX	Rotary 1E	D10	E-15085-0XX	Rotary 1E	D10
E-1150-0XX	Rotary 1E	D10	E-15089-0XX	Rotary 1E	D10
E-1151-0XX	Rotary 1E	D10	E-15094-0XX	Rotary 2E	D12
E-1159-0XX	Rotary 2E	D12	E-15097-0XX	Rotary 1E	D10
E-1168-0XX	Rotary 4E	D18	E-15103-0XX	Rotary 7S	D26
E-1174-0XX	Rotary 4E	D18	E-15111-0XX	Rotary 2E	D12
E-1197-0XX	Rotary 7S	D26	E-15116-0XX	Rotary 7S	D26
E-1202-0XX	Rotary 6S	D24	E-15120-0XX	Rotary 4E	D18
E-1226-0XX	Rotary 4E	D18	E-15123-0XX	Rotary 6S	D24
E-1230-0XX	Rotary 6S	D24	E-15125-0XX	Rotary 4E	D18
E-1244-0XX	Rotary 2E	D12	E-15128-0XX	Rotary 3E	D16
E-1245-0XX	Rotary 3E	D16	E-15134-0XX	Rotary 7S	D26
E-1246-0XX	Rotary 4E	D18	E-15135-0XX	Rotary 4E	D18
E-1247-0XX	Rotary 4E	D18	E-15136-0XX	Rotary 6S	D24
E-1258-0XX	Rotary 4E	D18	E-15137-0XX	Rotary 7S	D26
E-1282-0XX	Rotary 1E	D10	E-15148-0XX	Rotary 1E	D10
E-1286-0XX	Rotary 6S	D24	E-15165-0XX	Rotary 5S	D22

# Index of Part Numbers

**ERMEC**

Distribución de componentes eléctricos y electrónicos  
 Tel.: (+34)902.450.160  
 Fax: (+34)902.433.088  
[info@ermec.com](mailto:info@ermec.com)  
[www.ermec.com](http://www.ermec.com)

E-15200-0XX	Rotary 1E	D10	E-2268-0XX	Rotary 3E	D16
E-15201-0XX	Rotary 1E	D10	E-2269-0XX	Rotary 6S	D24
E-15202-0XX	Rotary 1E	D10	E-2276-0XX	Rotary 3E	D16
E-15203-0XX	Rotary 1E	D10	E-2300-0XX	Rotary 5S	D22
E-15204-0XX	Rotary 1E	D10	E-2309-0XX	Rotary 7S	D26
E-15205-0XX	Rotary 1E	D10	E-2323-0XX	Rotary 7S	D26
E-15206-0XX	Rotary 1E	D10	E-2328-0XX	Rotary 6S	D24
E-15207-0XX	Rotary 1E	D10	E-2330-0XX	Rotary 3E	D16
E-15208-0XX	Rotary 1E	D10	E-2346-0XX	Rotary 2E	D12
E-15210-0XX	Rotary 1E	D10	E-2355-0XX	Rotary 7S	D26
E-15211-0XX	Rotary 1E	D10	E-2362-0XX	Rotary 2E	D12
E-15212-0XX	Rotary 1E	D10	E-2383-0XX	Rotary 5S	D22
E-15213-0XX	Rotary 1E	D10	E-2388-0XX	Rotary 7S	D26
E-15214-0XX	Rotary 1E	D10	E-2389-0XX	Rotary 2E	D12
E-15215-0XX	Rotary 1E	D10	E-2390-0XX	Rotary 2E	D12
E-15216-0XX	Rotary 1E	D10	E-2397-0XX	Rotary 5S	D22
E-15217-0XX	Rotary 1E	D10	E-2411-0XX	Rotary 2E	D12
E-15218-0XX	Rotary 1E	D10	E-2412-0XX	Rotary 3E	D16
E-15219-0XX	Rotary 1E	D10	E-2413-0XX	Rotary 4E	D18
E-15220-0XX	Rotary 2E	D12	E-2414-0XX	Rotary 5S	D22
E-15221-0XX	Rotary 3E	D16	E-2415-0XX	Rotary 7S	D26
E-15229-0XX	Rotary 4E	D18	E-2419-0XX	Rotary 3E	D16
E-15230-0XX	Rotary 4E	D18	E-2434-0XX	Rotary 5S	D22
E-15231-0XX	Rotary 4E	D18	E-2436-0XX	Rotary 2E	D12
E-15236-0XX	Rotary 4E	D18	E-2437-0XX	Rotary 3E	D16
E-15237-0XX	Rotary 4E	D18	E-2444-0XX	Rotary 3E	D16
E-15238-0XX	Rotary 4E	D18	E-2450-0XX	Rotary 2E	D12
E-15412-0XX	Rotary 6S	D24	E-2452-0XX	Rotary 2E	D12
E-15417-0XX	Rotary 6S	D24	E-2453-0XX	Rotary 3E	D16
E-15418-0XX	Rotary 6S	D24	E-2477-0XX	Rotary 7S	D26
E-15424-0XX	Rotary 6S	D24	E-2479-0XX	Rotary 5S	D22
E-15485-0XX	Rotary 7S	D26	E-2480-0XX	Rotary 5S	D22
E-15491-0XX	Rotary 7S	D26	E-2481-0XX	Rotary 6S	D24
E-15492-0XX	Rotary 7S	D26	E-2483-0XX	Rotary 2E	D12
E-15493-0XX	Rotary 7S	D26	E-2484-0XX	Rotary 6S	D24
E-15498-0XX	Rotary 7S	D26	E-2485-0XX	Rotary 6S	D24
E-15502-0XX	Rotary 7S	D26	E-2490-0XX	Rotary 7S	D26
E-15503-0XX	Rotary 7S	D26	E-2510-0XX	Rotary 6S	D24
E-15615-0XX	Rotary 2E	D12	E-2512-0XX	Rotary 3E	D16
E-15616-0XX	Rotary 7S	D26	E-2527-0XX	Rotary 5S	D22
E-2008-0XX	Rotary 3E	D16	E-2537-0XX	Rotary 2E	D12
E-2016-0XX	Rotary 5S	D22	E-2555-0XX	Rotary 5S	D22
E-2050-0XX	Rotary 5S	D22	E-2556-0XX	Rotary 3E	D16
E-2057-0XX	Rotary 6S	D24	E-2560-0XX	Rotary 5S	D22
E-2073-0XX	Rotary 5S	D22	E-2562-0XX	Rotary 3E	D16
E-2116-0XX	Rotary 2E	D12	E-2590-0XX	Rotary 7S	D26
E-2117-0XX	Rotary 2E	D12	E-2592-0XX	Rotary 7S	D26
E-2126-0XX	Rotary 3E	D16	E-2593-0XX	Rotary 5S	D22
E-2127-0XX	Rotary 3E	D16	E-2613-0XX	Rotary 3E	D16
E-2136-0XX	Rotary 5S	D22	E-2616-0XX	Rotary 3E	D16
E-2159-0XX	Rotary 3E	D16	E-2634-0XX	Rotary 3E	D16
E-2168-0XX	Rotary 2E	D12	E-2650-0XX	Rotary 4E	D18
E-2184-0XX	Rotary 6S	D24	E-2657-0XX	Rotary 5S	D22
E-2185-0XX	Rotary 5S	D22	E-2658-0XX	Rotary 5S	D22
E-2186-0XX	Rotary 5S	D22	E-2668-0XX	Rotary 5S	D22
E-2193-0XX	Rotary 2E	D12	E-2669-0XX	Rotary 5S	D22
E-2209-0XX	Rotary 3E	D16	E-2670-0XX	Rotary 2E	D12
E-2216-0XX	Rotary 3E	D16	E-2681-0XX	Rotary 5S	D22
E-2259-0XX	Rotary 3E	D16	E-2685-0XX	Rotary 2E	D12
E-2264-0XX	Rotary 2E	D12	E-2698-0XX	Rotary 6S	D24
E-2265-0XX	Rotary 2E	D12	E-2708-0XX	Rotary 5S	D22

# Index of Part Numbers

E-2711-0XX	Rotary 3E	D16	E-3376-0XX	Rotary 6S	D24
E-2712-0XX	Rotary 3E	D16	E-3378-0XX	Rotary 4E	D18
E-2722-0XX	Rotary 3E	D16	E-3379-0XX	Rotary 4E	D18
E-2723-0XX	Rotary 3E	D16	E-3380-0XX	Rotary 1E	D10
E-2741-0XX	Rotary 4E	D18	E-3384-0XX	Rotary 5S	D22
E-2744-0XX	Rotary 2E	D12	E-3397-0XX	Rotary 5S	D22
E-2748-0XX	Rotary 2E	D12	E-3398-0XX	Rotary 3E	D16
E-2817-0XX	Rotary 6S	D24	E-3401-0XX	Rotary 3E	D16
E-2845-0XX	Rotary 5S	D22	E-3405-0XX	Rotary 2E	D12
E-2861-0XX	Rotary 6S	D24	E-3406-0XX	Rotary 7S	D26
E-2874-0XX	Rotary 5S	D22	E-3421-0XX	Rotary 5S	D22
E-2875-0XX	Rotary 5S	D22	M-1002-0XX	Rotary 6S	D24
E-2893-0XX	Rotary 4E	D18	M-1005-0XX	Rotary 6S	D24
E-2900-0XX	Rotary 4E	D18	M-1020-0XX	Rotary 5S	D22
E-2906-0XX	Rotary 3E	D16	M-1024-0XX	Rotary 2E	D12
E-2916-0XX	Rotary 6S	D24	M-1075-0XX	Rotary 3E	D16
E-2933-0XX	Rotary 2E	D12	M-1078-0XX	Rotary 6S	D24
E-2942-0XX	Rotary 6S	D24	M-1079-0XX	Rotary 2E	D12
E-2950-0XX	Rotary 7S	D26	M-1082-0XX	Rotary 5S	D22
E-2952-0XX	Rotary 4E	D18	M-1087-0XX	Rotary 5S	D22
E-2964-0XX	Rotary 6S	D24	M-1088-0XX	Rotary 2E	D12
E-2975-0XX	Rotary 4E	D18	M-1094-0XX	Rotary 2E	D12
E-2978-0XX	Rotary 3E	D16	M-1112-0XX	Rotary 6S	D24
E-2980-0XX	Rotary 4E	D18	M-1115-0XX	Rotary 4E	D18
E-2992-0XX	Rotary 3E	D16	M-1125-0XX	Rotary 5S	D22
E-2994-0XX	Rotary 2E	D12	M-1132-0XX	Rotary 4E	D18
E-2995-0XX	Rotary 4E	D18	M-1135-0XX	Rotary 3E	D16
E-3007-0XX	Rotary 7S	D26	M-1140-0XX	Rotary 1E	D10
E-3044-0XX	Rotary 3E	D16	M-1141-0XX	Rotary 1E	D10
E-3045-0XX	Rotary 3E	D16	M-1142-0XX	Rotary 1E	D10
E-3055-0XX	Rotary 6S	D24	M-1143-0XX	Rotary 1E	D10
E-3057-0XX	Rotary 7S	D26	M-1144-0XX	Rotary 1E	D10
E-3070-0XX	Rotary 7S	D26	M-1145-0XX	Rotary 1E	D10
E-3071-0XX	Rotary 4E	D18	M-1146-0XX	Rotary 1E	D10
E-3096-0XX	Rotary 7S	D26	M-1147-0XX	Rotary 1E	D10
E-3108-0XX	Rotary 4E	D18	M-1148-0XX	Rotary 1E	D10
E-3112-0XX	Rotary 2E	D12	M-1149-0XX	Rotary 1E	D10
E-3125-0XX	Rotary 4E	D18	M-1150-0XX	Rotary 1E	D10
E-3126-0XX	Rotary 4E	D18	M-1151-0XX	Rotary 1E	D10
E-3136-0XX	Rotary 6S	D24	M-1154-0XX	Rotary 5S	D22
E-3148-0XX	Rotary 7S	D26	M-1155-0XX	Rotary 5S	D22
E-3151-0XX	Rotary 5S	D22	M-1159-0XX	Rotary 2E	D12
E-3169-0XX	Rotary 3E	D16	M-1168-0XX	Rotary 4E	D18
E-3189-0XX	Rotary 5S	D22	M-1174-0XX	Rotary 4E	D18
E-3208-0XX	Rotary 6S	D24	M-1178-0XX	Rotary 7S	D26
E-3238-0XX	Rotary 5S	D22	M-1182-0XX	Rotary 6S	D24
E-3244-0XX	Rotary 2E	D12	M-1197-0XX	Rotary 7S	D26
E-3245-0XX	Rotary 2E	D12	M-1202-0XX	Rotary 6S	D24
E-3258-0XX	Rotary 4E	D18	M-1218-0XX	Rotary 4E	D18
E-3259-0XX	Rotary 2E	D12	M-1226-0XX	Rotary 4E	D18
E-3265-0XX	Rotary 2E	D12	M-1230-0XX	Rotary 6S	D24
E-3271-0XX	Rotary 4E	D18	M-1244-0XX	Rotary 2E	D12
E-3276-0XX	Rotary 5S	D22	M-1245-0XX	Rotary 3E	D16
E-3308-0XX	Rotary 6S	D24	M-1246-0XX	Rotary 4E	D18
E-3311-0XX	Rotary 1E	D10	M-1247-0XX	Rotary 4E	D18
E-3324-0XX	Rotary 4E	D18	M-1248-0XX	Rotary 5S	D22
E-3334-0XX	Rotary 1E	D10	M-1258-0XX	Rotary 4E	D18
E-3352-0XX	Rotary 4E	D18	M-1263-0XX	Rotary 4E	D18
E-3362-0XX	Rotary 7S	D26	M-1282-0XX	Rotary 1E	D10
E-3365-0XX	Rotary 6S	D24	M-1286-0XX	Rotary 6S	D24
E-3374-0XX	Rotary 3E	D16			

# Index of Part Numbers

M-1291-OXX	Rotary 6S	D24	M-15076-OXX	Rotary 7S	D26
M-1294-OXX	Rotary 2E	D12	M-15080-OXX	Rotary 3E	D16
M-1305-OXX	Rotary 1E	D10	M-15084-OXX	Rotary 1E	D10
M-1306-OXX	Rotary 6S	D24	M-15085-OXX	Rotary 1E	D10
M-1307-OXX	Rotary 5S	D22	M-15089-OXX	Rotary 1E	D10
M-1308-OXX	Rotary 5S	D22	M-15091-OXX	Rotary 4E	D18
M-1309-OXX	Rotary 4E	D18	M-15094-OXX	Rotary 2E	D12
M-1310-OXX	Rotary 4E	D18	M-15095-OXX	Rotary 6S	D24
M-1311-OXX	Rotary 6S	D24	M-15097-OXX	Rotary 1E	D10
M-1312-OXX	Rotary 7S	D26	M-15103-OXX	Rotary 7S	D26
M-1313-OXX	Rotary 6S	D24	M-15104-OXX	Rotary 7S	D26
M-1316-OXX	Rotary 7S	D26	M-15107-OXX	Rotary 3E	D16
M-1317-OXX	Rotary 7S	D26	M-15111-OXX	Rotary 2E	D12
M-1330-OXX	Rotary 3E	D16	M-15116-OXX	Rotary 7S	D26
M-1334-OXX	Rotary 7S	D26	M-15120-OXX	Rotary 4E	D18
M-1344-OXX	Rotary 2E	D12	M-15121-OXX	Rotary 7S	D26
M-1345-OXX	Rotary 5S	D22	M-15122-OXX	Rotary 4E	D18
M-1351-OXX	Rotary 6S	D24	M-15123-OXX	Rotary 6S	D24
M-1352-OXX	Rotary 7S	D26	M-15125-OXX	Rotary 4E	D18
M-1353-OXX	Rotary 7S	D26	M-15127-OXX	Rotary 4E	D18
M-1354-OXX	Rotary 7S	D26	M-15128-OXX	Rotary 3E	D16
M-1355-OXX	Rotary 7S	D26	M-15131-OXX	Rotary 5S	D22
M-1356-OXX	Rotary 7S	D26	M-15134-OXX	Rotary 7S	D26
M-1357-OXX	Rotary 7S	D26	M-15135-OXX	Rotary 4E	D18
M-1390-OXX	Rotary 5S	D22	M-15136-OXX	Rotary 6S	D24
M-1423-OXX	Rotary 5S	D22	M-15137-OXX	Rotary 7S	D26
M-1428-OXX	Rotary 7S	D26	M-15148-OXX	Rotary 1E	D10
M-1431-OXX	Rotary 5S	D22	M-15150-OXX	Rotary 5S	D22
M-1435-OXX	Rotary 4E	D18	M-15158-OXX	Rotary 7S	D26
M-1467-OXX	Rotary 7S	D26	M-15165-OXX	Rotary 5S	D22
M-1480-OXX	Rotary 7S	D26	M-15200-OXX	Rotary 1E	D10
M-1481-OXX	Rotary 6S	D24	M-15201-OXX	Rotary 1E	D10
M-1483-OXX	Rotary 6S	D24	M-15202-OXX	Rotary 1E	D10
M-1484-OXX	Rotary 7S	D26	M-15203-OXX	Rotary 1E	D10
M-15000-OXX	Rotary 4E	D18	M-15204-OXX	Rotary 1E	D10
M-15001-OXX	Rotary 4E	D18	M-15205-OXX	Rotary 1E	D10
M-15004-OXX	Rotary 2E	D12	M-15206-OXX	Rotary 1E	D10
M-15005-OXX	Rotary 3E	D16	M-15207-OXX	Rotary 1E	D10
M-15009-OXX	Rotary 7S	D26	M-15208-OXX	Rotary 1E	D10
M-15011-OXX	Rotary 4E	D18	M-1521-OXX	Rotary 4E	D18
M-15013-OXX	Rotary 6S	D24	M-15210-OXX	Rotary 1E	D10
M-15014-OXX	Rotary 7S	D26	M-15211-OXX	Rotary 1E	D10
M-15015-OXX	Rotary 4E	D18	M-15212-OXX	Rotary 1E	D10
M-15016-OXX	Rotary 4E	D18	M-15213-OXX	Rotary 1E	D10
M-15020-OXX	Rotary 3E	D16	M-15214-OXX	Rotary 1E	D10
M-15021-OXX	Rotary 4E	D18	M-15215-OXX	Rotary 1E	D10
M-15023-OXX	Rotary 6S	D24	M-15216-OXX	Rotary 1E	D10
M-15024-OXX	Rotary 6S	D24	M-15217-OXX	Rotary 1E	D10
M-15030-OXX	Rotary 6S	D24	M-15218-OXX	Rotary 1E	D10
M-15036-OXX	Rotary 6S	D24	M-15219-OXX	Rotary 1E	D10
M-15039-OXX	Rotary 1E	D10	M-15220-OXX	Rotary 2E	D12
M-15040-OXX	Rotary 3E	D16	M-15221-OXX	Rotary 3E	D16
M-15046-OXX	Rotary 2E	D12	M-15222-OXX	Rotary 4E	D18
M-15054-OXX	Rotary 7S	D26	M-15223-OXX	Rotary 4E	D18
M-15055-OXX	Rotary 5S	D22	M-15224-OXX	Rotary 4E	D18
M-15061-OXX	Rotary 7S	D26	M-15225-OXX	Rotary 4E	D18
M-15064-OXX	Rotary 6S	D24	M-15226-OXX	Rotary 4E	D18
M-15066-OXX	Rotary 6S	D24	M-15227-OXX	Rotary 4E	D18
M-15067-OXX	Rotary 6S	D24	M-15228-OXX	Rotary 4E	D18
M-15071-OXX	Rotary 3E	D16	M-15229-OXX	Rotary 4E	D18
M-15072-OXX	Rotary 5S	D22	M-15230-OXX	Rotary 4E	D18

# Index of Part Numbers

M-15231-0XX	Rotary 4E	D18	M-15417-0XX	Rotary 6S	D24
M-15232-0XX	Rotary 4E	D18	M-15418-0XX	Rotary 6S	D24
M-15233-0XX	Rotary 4E	D18	M-15419-0XX	Rotary 6S	D24
M-15234-0XX	Rotary 4E	D18	M-15420-0XX	Rotary 6S	D24
M-15235-0XX	Rotary 4E	D18	M-15421-0XX	Rotary 6S	D24
M-15236-0XX	Rotary 4E	D18	M-15422-0XX	Rotary 6S	D24
M-15237-0XX	Rotary 4E	D18	M-15423-0XX	Rotary 6S	D24
M-15238-0XX	Rotary 4E	D18	M-15424-0XX	Rotary 6S	D24
M-15239-0XX	Rotary 4E	D18	M-15425-0XX	Rotary 6S	D24
M-15305-0XX	Rotary 5S	D22	M-15426-0XX	Rotary 6S	D24
M-15306-0XX	Rotary 5S	D22	M-15427-0XX	Rotary 6S	D24
M-15307-0XX	Rotary 5S	D22	M-15428-0XX	Rotary 6S	D24
M-15308-0XX	Rotary 5S	D22	M-15429-0XX	Rotary 6S	D24
M-15309-0XX	Rotary 5S	D22	M-15485-0XX	Rotary 7S	D26
M-15310-0XX	Rotary 5S	D22	M-15486-0XX	Rotary 7S	D26
M-15311-0XX	Rotary 5S	D22	M-15487-0XX	Rotary 7S	D26
M-15312-0XX	Rotary 5S	D22	M-15488-0XX	Rotary 7S	D26
M-15313-0XX	Rotary 5S	D22	M-15490-0XX	Rotary 7S	D26
M-15314-0XX	Rotary 5S	D22	M-15491-0XX	Rotary 7S	D26
M-15315-0XX	Rotary 5S	D22	M-15492-0XX	Rotary 7S	D26
M-15316-0XX	Rotary 5S	D22	M-15493-0XX	Rotary 7S	D26
M-15317-0XX	Rotary 5S	D22	M-15494-0XX	Rotary 7S	D26
M-15318-0XX	Rotary 5S	D22	M-15495-0XX	Rotary 7S	D26
M-15319-0XX	Rotary 5S	D22	M-15496-0XX	Rotary 7S	D26
M-15320-0XX	Rotary 5S	D22	M-15497-0XX	Rotary 7S	D26
M-15321-0XX	Rotary 5S	D22	M-15498-0XX	Rotary 7S	D26
M-15322-0XX	Rotary 5S	D22	M-15499-0XX	Rotary 7S	D26
M-15323-0XX	Rotary 5S	D22	M-15500-0XX	Rotary 7S	D26
M-15324-0XX	Rotary 5S	D22	M-15501-0XX	Rotary 7S	D26
M-15325-0XX	Rotary 5S	D22	M-15502-0XX	Rotary 7S	D26
M-15326-0XX	Rotary 5S	D22	M-15503-0XX	Rotary 7S	D26
M-15327-0XX	Rotary 5S	D22	M-15504-0XX	Rotary 7S	D26
M-15328-0XX	Rotary 5S	D22	M-15505-0XX	Rotary 7S	D26
M-15329-0XX	Rotary 5S	D22	M-15506-0XX	Rotary 7S	D26
M-15330-0XX	Rotary 5S	D22	M-15614-0XX	Rotary 7S	D26
M-15331-0XX	Rotary 5S	D22	M-15615-0XX	Rotary 2E	D12
M-15332-0XX	Rotary 5S	D22	M-15616-0XX	Rotary 7S	D26
M-15333-0XX	Rotary 5S	D22	M-2001-0XX	Rotary 6S	D24
M-15334-0XX	Rotary 5S	D22	M-2008-0XX	Rotary 3E	D16
M-15335-0XX	Rotary 5S	D22	M-2010-0XX	Rotary 5S	D22
M-15336-0XX	Rotary 5S	D22	M-2016-0XX	Rotary 5S	D22
M-15337-0XX	Rotary 5S	D22	M-2050-0XX	Rotary 5S	D22
M-15338-0XX	Rotary 5S	D22	M-2057-0XX	Rotary 6S	D24
M-15339-0XX	Rotary 5S	D22	M-2071-0XX	Rotary 6S	D24
M-15400-0XX	Rotary 6S	D24	M-2072-0XX	Rotary 6S	D24
M-15401-0XX	Rotary 6S	D24	M-2073-0XX	Rotary 5S	D22
M-15402-0XX	Rotary 6S	D24	M-2074-0XX	Rotary 5S	D22
M-15403-0XX	Rotary 6S	D24	M-2075-0XX	Rotary 5S	D22
M-15404-0XX	Rotary 6S	D24	M-2116-0XX	Rotary 2E	D12
M-15405-0XX	Rotary 6S	D24	M-2117-0XX	Rotary 2E	D12
M-15406-0XX	Rotary 6S	D24	M-2126-0XX	Rotary 3E	D16
M-15407-0XX	Rotary 6S	D24	M-2127-0XX	Rotary 3E	D16
M-15408-0XX	Rotary 6S	D24	M-2128-0XX	Rotary 3E	D16
M-15409-0XX	Rotary 6S	D24	M-2136-0XX	Rotary 5S	D22
M-15410-0XX	Rotary 6S	D24	M-2150-0XX	Rotary 5S	D22
M-15411-0XX	Rotary 6S	D24	M-2159-0XX	Rotary 3E	D16
M-15412-0XX	Rotary 6S	D24	M-2168-0XX	Rotary 2E	D12
M-15413-0XX	Rotary 6S	D24	M-2181-0XX	Rotary 6S	D24
M-15414-0XX	Rotary 6S	D24	M-2184-0XX	Rotary 6S	D24
M-15415-0XX	Rotary 6S	D24	M-2185-0XX	Rotary 5S	D22
M-15416-0XX	Rotary 6S	D24	M-2186-0XX	Rotary 5S	D22

# Index of Part Numbers

M-2193-0XX	Rotary 2E	D12	M-2542-0XX	Rotary 3E	D16
M-2209-0XX	Rotary 3E	D16	M-2550-0XX	Rotary 3E	D16
M-2216-0XX	Rotary 3E	D16	M-2555-0XX	Rotary 5S	D22
M-2223-0XX	Rotary 6S	D24	M-2556-0XX	Rotary 3E	D16
M-2259-0XX	Rotary 3E	D16	M-2560-0XX	Rotary 5S	D22
M-2262-0XX	Rotary 5S	D22	M-2562-0XX	Rotary 3E	D16
M-2264-0XX	Rotary 2E	D12	M-2563-0XX	Rotary 4E	D18
M-2265-0XX	Rotary 2E	D12	M-2590-0XX	Rotary 7S	D26
M-2268-0XX	Rotary 3E	D16	M-2592-0XX	Rotary 7S	D26
M-2269-0XX	Rotary 6S	D24	M-2593-0XX	Rotary 5S	D22
M-2276-0XX	Rotary 3E	D16	M-2613-0XX	Rotary 3E	D16
M-2288-0XX	Rotary 3E	D16	M-2616-0XX	Rotary 3E	D16
M-2289-0XX	Rotary 3E	D16	M-2626-0XX	Rotary 4E	D18
M-2293-0XX	Rotary 6S	D24	M-2634-0XX	Rotary 3E	D16
M-2296-0XX	Rotary 5S	D22	M-2640-0XX	Rotary 4E	D18
M-2300-0XX	Rotary 5S	D22	M-2643-0XX	Rotary 6S	D24
M-2303-0XX	Rotary 7S	D26	M-2645-0XX	Rotary 4E	D18
M-2309-0XX	Rotary 7S	D26	M-2650-0XX	Rotary 4E	D18
M-2310-0XX	Rotary 4E	D18	M-2657-0XX	Rotary 5S	D22
M-2323-0XX	Rotary 7S	D26	M-2658-0XX	Rotary 5S	D22
M-2328-0XX	Rotary 6S	D24	M-2661-0XX	Rotary 6S	D24
M-2330-0XX	Rotary 3E	D16	M-2668-0XX	Rotary 5S	D22
M-2346-0XX	Rotary 2E	D12	M-2669-0XX	Rotary 5S	D22
M-2349-0XX	Rotary 5S	D22	M-2670-0XX	Rotary 2E	D12
M-2355-0XX	Rotary 7S	D26	M-2671-0XX	Rotary 6S	D24
M-2362-0XX	Rotary 2E	D12	M-2681-0XX	Rotary 5S	D22
M-2382-0XX	Rotary 5S	D22	M-2685-0XX	Rotary 2E	D12
M-2383-0XX	Rotary 5S	D22	M-2698-0XX	Rotary 6S	D24
M-2388-0XX	Rotary 7S	D26	M-2708-0XX	Rotary 5S	D22
M-2389-0XX	Rotary 2E	D12	M-2711-0XX	Rotary 3E	D16
M-2390-0XX	Rotary 2E	D12	M-2712-0XX	Rotary 3E	D16
M-2397-0XX	Rotary 5S	D22	M-2714-0XX	Rotary 5S	D22
M-2400-0XX	Rotary 7S	D26	M-2722-0XX	Rotary 3E	D16
M-2404-0XX	Rotary 6S	D24	M-2723-0XX	Rotary 3E	D16
M-2411-0XX	Rotary 2E	D12	M-2741-0XX	Rotary 4E	D18
M-2412-0XX	Rotary 3E	D16	M-2744-0XX	Rotary 2E	D12
M-2413-0XX	Rotary 4E	D18	M-2747-0XX	Rotary 5S	D22
M-2414-0XX	Rotary 5S	D22	M-2748-0XX	Rotary 2E	D12
M-2415-0XX	Rotary 7S	D26	M-2809-0XX	Rotary 7S	D26
M-2419-0XX	Rotary 3E	D16	M-2817-0XX	Rotary 6S	D24
M-2434-0XX	Rotary 5S	D22	M-2826-0XX	Rotary 6S	D24
M-2436-0XX	Rotary 2E	D12	M-2845-0XX	Rotary 5S	D22
M-2437-0XX	Rotary 3E	D16	M-2858-0XX	Rotary 7S	D26
M-2444-0XX	Rotary 3E	D16	M-2861-0XX	Rotary 6S	D24
M-2450-0XX	Rotary 2E	D12	M-2862-0XX	Rotary 4E	D18
M-2452-0XX	Rotary 2E	D12	M-2869-0XX	Rotary 7S	D26
M-2453-0XX	Rotary 3E	D16	M-2874-0XX	Rotary 5S	D22
M-2477-0XX	Rotary 7S	D26	M-2875-0XX	Rotary 5S	D22
M-2479-0XX	Rotary 5S	D22	M-2893-0XX	Rotary 4E	D18
M-2480-0XX	Rotary 5S	D22	M-2900-0XX	Rotary 4E	D18
M-2481-0XX	Rotary 6S	D24	M-2902-0XX	Rotary 5S	D22
M-2483-0XX	Rotary 2E	D12	M-2906-0XX	Rotary 3E	D16
M-2484-0XX	Rotary 6S	D24	M-2916-0XX	Rotary 6S	D24
M-2485-0XX	Rotary 6S	D24	M-2929-0XX	Rotary 4E	D18
M-2490-0XX	Rotary 7S	D26	M-2930-0XX	Rotary 4E	D18
M-2510-0XX	Rotary 6S	D24	M-2933-0XX	Rotary 2E	D12
M-2512-0XX	Rotary 3E	D16	M-2936-0XX	Rotary 6S	D24
M-2522-0XX	Rotary 5S	D22	M-2940-0XX	Rotary 3E	D16
M-2527-0XX	Rotary 5S	D22	M-2942-0XX	Rotary 6S	D24
M-2537-0XX	Rotary 2E	D12	M-2950-0XX	Rotary 7S	D26

# Index of Part Numbers

M-2952-0XX	Rotary 4E	D18	M-3244-0XX	Rotary 2E	D12
M-2957-0XX	Rotary 5S	D22	M-3245-0XX	Rotary 2E	D12
M-2964-0XX	Rotary 6S	D24	M-3249-0XX	Rotary 5S	D22
M-2967-0XX	Rotary 4E	D18	M-3258-0XX	Rotary 4E	D18
M-2975-0XX	Rotary 4E	D18	M-3259-0XX	Rotary 2E	D12
M-2978-0XX	Rotary 3E	D16	M-3264-0XX	Rotary 6S	D24
M-2980-0XX	Rotary 4E	D18	M-3265-0XX	Rotary 2E	D12
M-2992-0XX	Rotary 3E	D16	M-3271-0XX	Rotary 4E	D18
M-2994-0XX	Rotary 2E	D12	M-3276-0XX	Rotary 5S	D22
M-2995-0XX	Rotary 4E	D18	M-3278-0XX	Rotary 3E	D16
M-3002-0XX	Rotary 6S	D24	M-3279-0XX	Rotary 3E	D16
M-3004-0XX	Rotary 3E	D16	M-3289-0XX	Rotary 7S	D26
M-3007-0XX	Rotary 7S	D26	M-3308-0XX	Rotary 6S	D24
M-3037-0XX	Rotary 7S	D26	M-3311-0XX	Rotary 1E	D10
M-3044-0XX	Rotary 3E	D16	M-3324-0XX	Rotary 4E	D18
M-3045-0XX	Rotary 3E	D16	M-3334-0XX	Rotary 1E	D10
M-3055-0XX	Rotary 6S	D24	M-3350-0XX	Rotary 7S	D26
M-3057-0XX	Rotary 7S	D26	M-3352-0XX	Rotary 4E	D18
M-3069-0XX	Rotary 7S	D26	M-3362-0XX	Rotary 7S	D26
M-3070-0XX	Rotary 7S	D26	M-3365-0XX	Rotary 6S	D24
M-3071-0XX	Rotary 4E	D18	M-3374-0XX	Rotary 3E	D16
M-3074-0XX	Rotary 4E	D18	M-3375-0XX	Rotary 5S	D22
M-3084-0XX	Rotary 4E	D18	M-3376-0XX	Rotary 6S	D24
M-3096-0XX	Rotary 7S	D26	M-3377-0XX	Rotary 5S	D22
M-3108-0XX	Rotary 4E	D18	M-3378-0XX	Rotary 4E	D18
M-3112-0XX	Rotary 2E	D12	M-3379-0XX	Rotary 4E	D18
M-3117-0XX	Rotary 4E	D18	M-3380-0XX	Rotary 1E	D10
M-3125-0XX	Rotary 4E	D18	M-3381-0XX	Rotary 3E	D16
M-3126-0XX	Rotary 4E	D18	M-3384-0XX	Rotary 5S	D22
M-3136-0XX	Rotary 6S	D24	M-3385-0XX	Rotary 5S	D22
M-3148-0XX	Rotary 7S	D26	M-3397-0XX	Rotary 5S	D22
M-3151-0XX	Rotary 5S	D22	M-3398-0XX	Rotary 3E	D16
M-3169-0XX	Rotary 3E	D16	M-3399-0XX	Rotary 5S	D22
M-3189-0XX	Rotary 5S	D22	M-3400-0XX	Rotary 5S	D22
M-3208-0XX	Rotary 6S	D24	M-3401-0XX	Rotary 3E	D16
M-3230-0XX	Rotary 6S	D24	M-3402-0XX	Rotary 4E	D18
M-3238-0XX	Rotary 5S	D22	M-3405-0XX	Rotary 2E	D12
			M-3406-0XX	Rotary 7S	D26
			M-3421-0XX	Rotary 5S	D22
			M-3425-0XX	Rotary 4E	D18



ERMEC, S.L. BARCELONA  
C/ Francesc Teixidó, 22  
E-08918 Badalona  
(Spain)

Tel.: (+34) 902 450 160  
Fax: (+34) 902 433 088  
[ermec@ermec.org](mailto:ermec@ermec.org)  
[www.ermec.org](http://www.ermec.org)

ERMEC, S.L. MADRID  
C/ Sagasta, 8, 1ª planta  
E-28004 Madrid  
(Spain)

PORTUGAL  
[portugal@ermec.com](mailto:portugal@ermec.com)

## Headquarters

Johnson Electric Holdings Limited  
Johnson Building, 6-22 Dai Shun St, Tai Po Industrial  
Estate, New Territories

### Hong Kong

Tel: +852 2663 6688  
Fax: +852 2897 2054  
e-mail: [salesupport@johnsonelectric.com](mailto:salesupport@johnsonelectric.com)

## Sales Offices

### Asia

#### Shanghai, China

12/F, Hua Rong Tower  
1289 Pudong Road South

#### Shanghai

200122 China  
T +86 21 5882 2880  
F +86 21 5882 2800

#### Tokyo, Japan

Keihin Higashi-Ohi Bldg.  
10/F, 2-13-8 Higashi-Ohi  
Shinagawa-ku

#### Tokyo 140-0011 Japan

T +81 3 5762 1031  
F +81 3 5762 1032

#### Seoul, Korea

Misung Bldg B127, 115-7  
Nonhyun-Dong, Kangnam-Gu,

#### Seoul, Korea 135-010

T +82 2 518 8347/8341  
F +82 2 518 8342

#### Singapore

50 Raffles Place #24-02,  
Singapore Land Tower

#### Singapore 048623

T +65 6224 7570  
F +65 6224 4538

### Europe

#### Austria

**Slovenia, Slovakia, Hungary,**  
Czech Republic  
Linzer Bundesstrasse 101

#### A-5023 Salzburg

T +43 662 88 4910  
F +43 662 88 4910 11

#### France

10 Bld. Louise Michel  
F-92230 **Gennevilliers**  
T +33 1 46 88 07 70  
F +33 1 46 88 07 99

78 Boulevard du 11 Novembre

#### 69003 Villeurbanne

T +33 4 37 48 84 60  
F +33 4 72 43 90 11

#### Germany

#### Sweden, Denmark,

#### Norway, Finland

Weissenpferd 9  
D-58553 **Halver**  
T +49 2353 911 0  
F +49 2353 911 230

#### Italy

Via Cadamosto 3  
I-20094 Corsico, **Milano**  
T +39 02 4869 21  
F +39 02 4860 0692

1, Via Vittime di Piazza Fontana

#### I-10024 Moncalieri

T +39 011 68 05 401  
F +39 011 68 05 411

#### Switzerland

#### Poland, Spain, Turkey, Portugal

Bahnhofstrasse 18

#### CH-3280 Murten

T +41 26 672 71 11  
F +41 26 670 19 83

#### The Netherlands/Belgium

#### Hanzeweg 12c

#### NL-2803 MC Gouda

T +31 1825 43 154  
F +31 1825 43 151

#### United Kingdom/Ireland

Dukesway  
Team Valley Trading Estate

#### Gateshead

Tyne & Wear NE11 0UB  
United Kingdom

T +44 191 401 61 00  
F +44 191 401 63 05

### Americas

#### Connecticut

10 Progress Drive, **Shelton,**  
CT 06484, USA

T +1 203 447 5362  
F +1 203 447 5383

#### Illinois

3115 N. Wilke Road - Suite C  
**Arlington Heights,**

#### IL 60004

T +1 847 368 2146  
F +1 847 368 2152

#### Ohio

801 Scholz Drive  
**Vandalia, OH 45377**

T +1 937 454 2345  
F +1 937 898 8624

#### Ontario, Canada

70 Ironside Crescent Unit 7  
Scarborough, **Ontario**

#### M1X 1G4 Canada

T +1 416 299 0852  
F +1 416 299 6756

#### Sao Paulo, Brazil

Av. Papa Joao Paulo I - 1256  
CEP 07170-350

#### Guarulhos Sao Paulo, Brazil

T (55) 11-643 156 00  
F (55) 11-643 247 11



ERMEC, S.L. BARCELONA  
C/ Francesc Teixidó, 22  
E-08918 Badalona  
(Spain)

Tel.: (+34) 902 450 160  
Fax: (+34) 902 433 088  
[ermec@ermec.org](mailto:ermec@ermec.org)  
[www.ermec.org](http://www.ermec.org)

ERMEC, S.L. MADRID  
C/ Sagasta, 8, 1ª planta  
E-28004 Madrid  
(Spain)

PORTUGAL  
[portugal@ermec.com](mailto:portugal@ermec.com)

### Johnson Electric Group

Johnson Building, 6-22 Dai Shun Street  
Tai Po Industrial Estate, N.T., Hong Kong

Tel: (852) 2663 6688

Fax: (852) 2663 6110

Web Site: [www.johnsonelectric.com](http://www.johnsonelectric.com)



ERMEC, S.L. BARCELONA  
C/ Francesc Teixidó, 22  
E-08918 Badalona  
(Spain)

Tel.: (+34) 902 450 160  
Fax: (+34) 902 433 088  
[ermec@ermec.org](mailto:ermec@ermec.org)  
[www.ermec.org](http://www.ermec.org)

ERMEC, S.L. MADRID  
C/ Sagasta, 8, 1ª planta  
E-28004 Madrid  
(Spain)

PORTUGAL  
[portugal@ermec.com](mailto:portugal@ermec.com)