

# Model 155

# STA<sup>®</sup> Pull DC Tubular Solenoid

Size: 1-1/2" OD X 1-11/16" L

ALL PRODUCTS ARE RoHS COMPLIANT

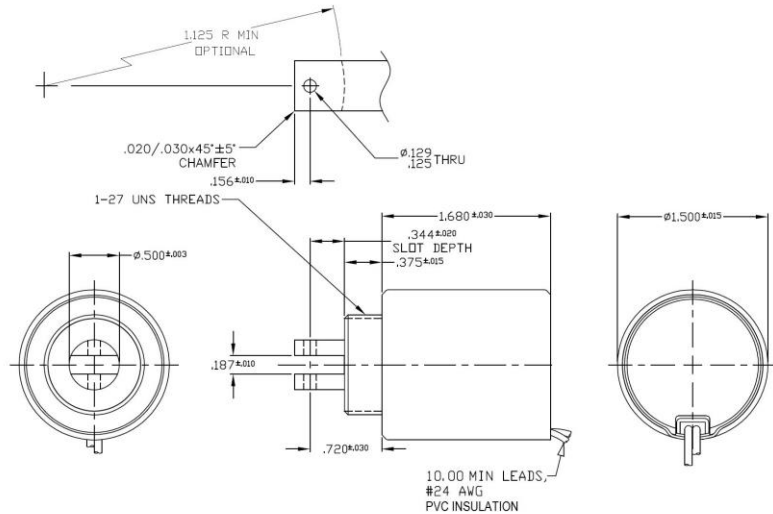

Solenoid shown energized with plunger fully extended  
 Supplied with hex nut shipped loose  
 Spring kits available (consult factory)

Part No.	Duty Cycle	Voltage	Resistance (Ω) ± 5%	Max On Time	Power (W)	Current (A)
152097-223	Intermittent	12 VDC	4.74	66 Secs	30.4	2.53
152097-226	Continuous	12 VDC	17.51	∞	8.2	0.69
152097-226	Intermittent	24 VDC	17.51	66 Secs	32.9	1.37
152097-229	Continuous	24 VDC	70.28	∞	8.2	0.34

Continuous Duty = 100% "On" Time  
 Intermittent Duty = 25% "On" Time  
 When ordering please refer to Part No. as listed above  
 Please consult factory for custom configurations and other pole face angles

Stroke (in.)	Typical Pull Force (oz.)								Holding Force (oz.)
	0.060	0.125	0.250	0.375	0.500	0.625	0.750	1.000	
Continuous Duty	83.4	52.1	25.3	14.1	8.9	4.8	2.4	N/A	155.2
Intermittent Duty	135.3	116.6	81.5	55.3	37.4	25.4	16.4	9.6	N/A

### Additional Specifications:

- Dielectric Strength: 1000 VRMS
- Recommended Heat Sink: Maximum watts dissipated by solenoid are based on an unrestricted flow of air at 20°C, with solenoid mounted to the equivalent of an aluminum plate measuring 6" square by 1/8" thick.
- Total Unit Weight: 11.3 oz. / 320 g
- Plunger Weight: 1.6 oz. / 46.0 g