

Resistors

Fibre Core Conformal Coated Wirewound Resistor

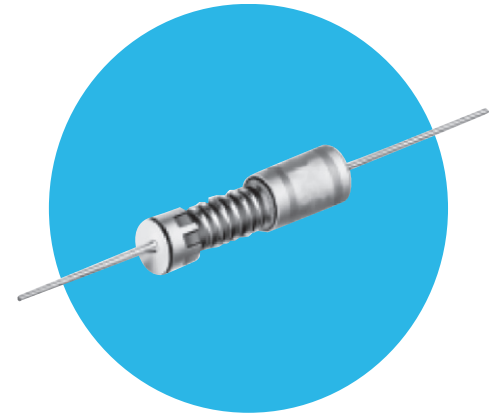

SPP Series

- UL1412 recognised fusing *
- Coated or uncoated units
- Positive high TC's upon request
- Color band standard identification
- Lower ranges available - contact factory
- Weldable and solderable magnetic leads

* UL file number E234469

All Pb-free parts comply with EU Directive 2011/65/EU amended by (EU) 2015/863 (RoHS3)

Electrical Data

IRC Type	SPP-1		SPP-2		SPP-3	
Resistance - Std.	0.1Ω to 1200Ω		0.1Ω to 2400Ω		0.1Ω to 2400Ω	
UL Recognised Range	1 Ω to 470 Ω		1 Ω to 470 Ω		---	
Tolerance - Std.	±5% (E24), ±10% (E12)					
Power Rating	1 watt @ 85°C 3/4 watt @ 105°C 1/2 watt @ 125°C Derating to 0 @ 160°C		2 watt @ 85°C 1 watt @ 140°C --- ---		3 watt @ 85°C 2 watt @ 145°C 1 watt @ 190°C ---	
Load Life Stability	1 watt @ 85°C ± 10%		2 watt @ 85°C ± 10%		3 watt @ 85°C ± 10%	
Max. Continuous Working Voltage	\sqrt{PR}		\sqrt{PR}		\sqrt{PR}	
Min. Insulation Resistance	Dry Wet	10,000 Meg 100 Meg	10,000 Meg 100 Meg	10,000 Meg 100 Meg	10,000 Meg 100 Meg	10,000 Meg 100 Meg
Min. Dielectric Withstanding Volts (RMS)	600V		600V		600V	
Current Noise	Negligible		Negligible		Negligible	
Temperature Rise at Rated Load, 25°C Ambient	Approx. 150°C		Approx. 200°C		Approx. 225°C	
Temperature Coefficient	±600/°C 0.10Ω - 0.91Ω	±300/°C 1Ω - 1200Ω	±600/°C 0.10Ω - 0.91Ω	±300/°C 1Ω - 2400Ω	±600/°C 0.10Ω - 0.91Ω	±300/°C 1Ω - 2400Ω

Notes:
Unless specified otherwise, standard test centers are 1 3/4 inches.

General Note

TT Electronics reserves the right to make changes in product specification without notice or liability.
All information is subject to TT Electronics' own data and is considered accurate at time of going to print.

BI Technologies IRC Welwyn

www.ttelectronics.com/resistors

Fibre Core Conformal Wirewound Resistor

SPP Series

Environmental Data

Characteristics	Maximum Limits	
Temperature Coefficient (ppm/°C)	SPP-1	±600/°C 0.10Ω - 0.91Ω ±300/°C 1.0Ω - 1200Ω
	SPP-2	±600/°C 0.10Ω - 0.91Ω ±300/°C 1.0Ω - 2400Ω
	SPP-3	±600/°C 0.10Ω - 0.91Ω ±600/°C 1.0Ω - 2400Ω
Thermal Shock	±5%	
Low Shock	±5%	
Short Time Overload	±5%	
Commercial Short Time Overload	±5%	
Resistance to Solder Immersion	±3%	
Solderability	95% minimum coverage	
Moisture Resistance	±5%	
Life Test	±5%	
Test Method	EIA Specification RS-344	

Physical Data

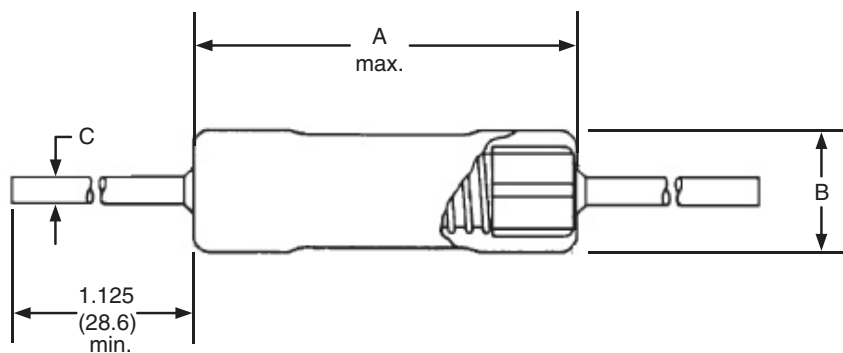

Dimensions (Inches and (mm))			
IRC Type	A	B	C ± .002(0.05)
SPP-1	0.400(10.2) max.	0.148(3.8) max.	0.032(0.8)
SPP-2	0.570(14.5) max.	0.170(4.3) max.	0.032(0.8)
SPP-3	0.570(14.5) max.	0.170(4.3) max.	0.032(0.8)

General Note

TT Electronics reserves the right to make changes in product specification without notice or liability. All information is subject to TT Electronics' own data and is considered accurate at time of going to print.