



4 Pad Ceramic Package, 2.5 mm x 3.2 mm



ILCX13 Series

Product Features:

- SMD Package
- Small package Foot Print
- Supplied in Tape and Reel
- Compatible with Leadfree Processing

Applications:

- PCMCIA Cards
- Storage
- PC's
- Wireless Lan

Frequency	10 MHz to 150 MHz
ESR (Equivalent Series Resistance)	
10.0 MHz – 11.9 MHz	200 Ω Max.
12.0 Mhz – 15.9 MHz	100 Ω Max.
16.0 MHz – 19.9 MHz	80 Ω Max.
20.0 MHz – 23.9 MHz	60 Ω Max.
24.0 MHz – 60.0 MHz	40 Ω Max.
60.0 MHz – 150.0 MHz (3 rd O/T)	100 Ω Max.
Shunt Capacitance (C0)	3.5 pF Max.
Frequency Tolerance @ 25° C	±30 ppm Standard (see Part Number Guide for more options)
Frequency Stability over Temperature	±50 ppm Standard (see Part Number Guide for more options)
Crystal Cut	AT Cut
Load Capacitance	18 pF Standard (see Part Number Guide for more options)
Drive Level	100 μW Max.
Aging	±5 ppm Max. / Year Standard
Temperature	
Operating	0° C to +70° C Standard (see Part Number Guide for more options)
Storage	-40° C to +85° C Standard

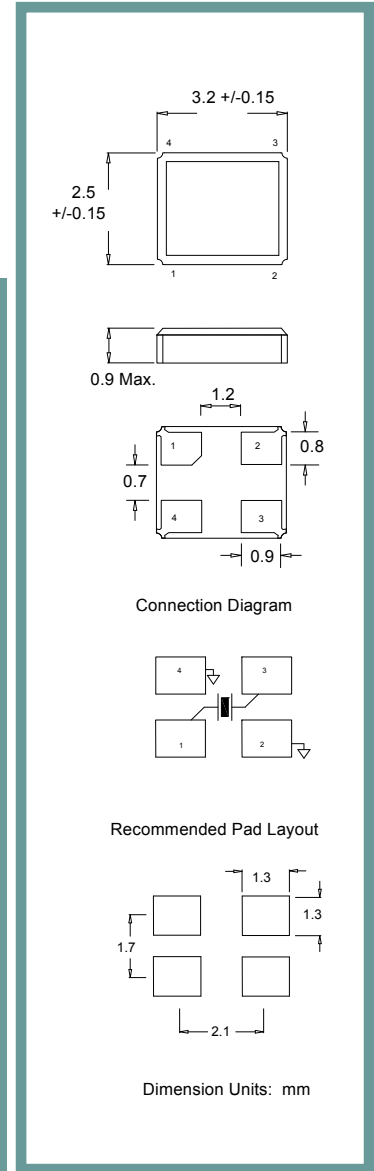

Part Number Guide		Sample Part Number: ILCX13 - FB1F18 - 20.000				
Package	Tolerance (ppm) at Room Temperature	Stability (ppm) over Operating Temperature	Operating Temperature Range	Mode (overtone)	Load Capacitance (pF)	Frequency
ILCX13 -	B = ±50 ppm	B = ±50 ppm	0 = 0°C to +50°C	F = Fundamental	18 pF Standard Or Specify	- 20.000 MHz
	F = ±30 ppm	F = ±30 ppm	1 = 0°C to +70°C	3 = 3 rd overtone		
	G = ±25 ppm	G = ±25 ppm	2 = -10°C to +60°C			
	H = ±20 ppm	H = ±20 ppm	3 = -20°C to +70°C			
	I = ±15 ppm	I = ±15 ppm**	5 = -40°C to +85°C			
	J = ±10 ppm*	J = ±10 ppm**	9 = -10°C to +50°C			
			D = -10°C to +105°C*			
		E = -40°C to +105°C*				

* Not available at all frequencies. ** Not available for all temperature ranges.



4 Pad Ceramic Package, 2.5 mm x 3.2 mm



ILCX13 Series

Pb Free Solder Reflow Profile:

Typical Circuit:

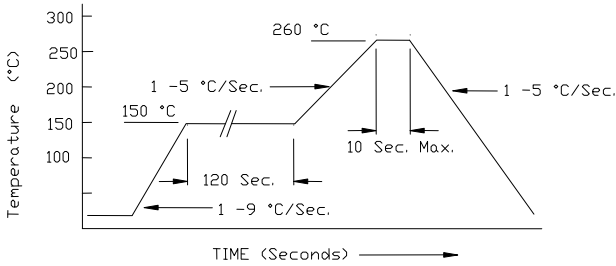

*Units are backward compatible with 240C reflow processes

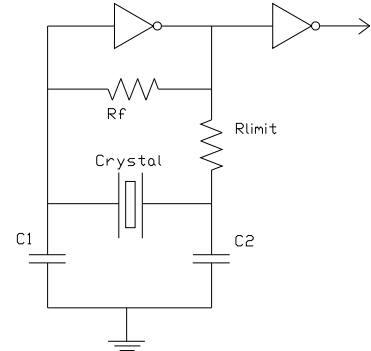

Package Information:

MSL = 1
Termination = e4 (Au over Ni over W base metal).

Tape and Reel Information:

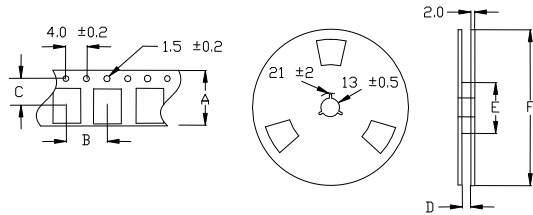

Quantity per Reel	3000
A	8.0+/- .2
B	4.0 +/- .2
C	3.5 +/- .2
D	12 +/- 3
E	60 / 80
F	180

Environmental Specifications

Thermal Shock	MIL-STD-883, Method 1011, Condition A
Moisture Resistance	MIL-STD-883, Method 1004
Mechanical Shock	MIL-STD-883, Method 2002, Condition B
Mechanical Vibration	MIL-STD-883, Method 2007, Condition A
Resistance to Soldering Heat	J-STD-020C, Table 5-2 Pb-free devices (except 2 cycles max)
Hazardous Substance	Pb-Free / RoHS / Green Compliant
Solderability	JESD22-B102-D Method 2 (Preconditioning E)
Terminal Strength	MIL-STD-883, Method 2004, Test Condition D
Gross Leak	MIL-STD-883, Method 1014, Condition C
Fine Leak	MIL-STD-883, Method 1014, Condition A2, R1=2x10 ⁻⁸ atm cc/s
Solvent Resistance	MIL-STD-202, Method 215

Marking

Line 1: I-Date Code (YWW)
Line 2: Frequency

PROPRIETARY AND CONFIDENTIAL

THIS DOCUMENT CONTAINS PROPRIETARY INFORMATION, AND SUCH INFORMATION MAY NOT BE DISCLOSED TO OTHERS FOR ANY PURPOSE NOR USED FOR MANUFACTURING PURPOSES WITHOUT WRITTEN PERMISSION FROM ILSI America.

**QUALITY SYSTEM
CERTIFIED
= ISO 9001 =**

ILSI America Phone 775-851-8880 • Fax 775-851-8882 • email: e-mail@ilsiamerica.com • www.ilsiamerica.com

Specifications subject to change without notice

Rev: 06/18/15_H

Page 2 of 2