

P	LTR	DESCRIPTION	DATE	DWN	APVD
	A	INITIAL RELEASE	20JUN2020	J.S	I.Y
	A1	ECR-20-010349	26JUL2020	J.G	I.Y
	A2	ECR-20-013768	28SEP2020	J.G	I.Y
	A3	ECN-21-113425	17AUG2021	J.G	Z.Z

12CCT PLUG CONNECTOR

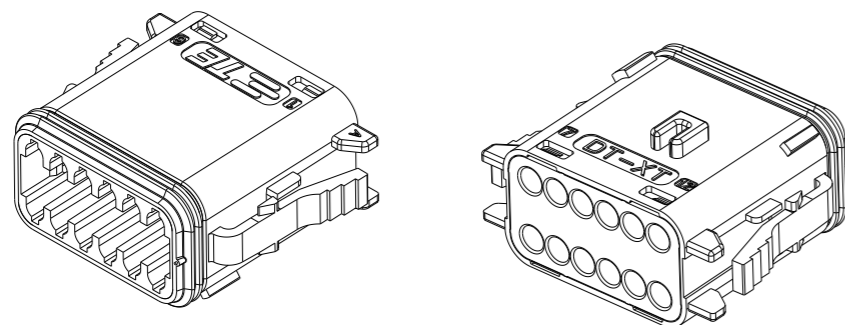

12CCT PLUG CONNECTOR WITH HEATSHRINK HOUSING ULTRASONICALLY WELDED IN PLACE

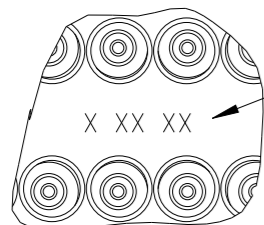
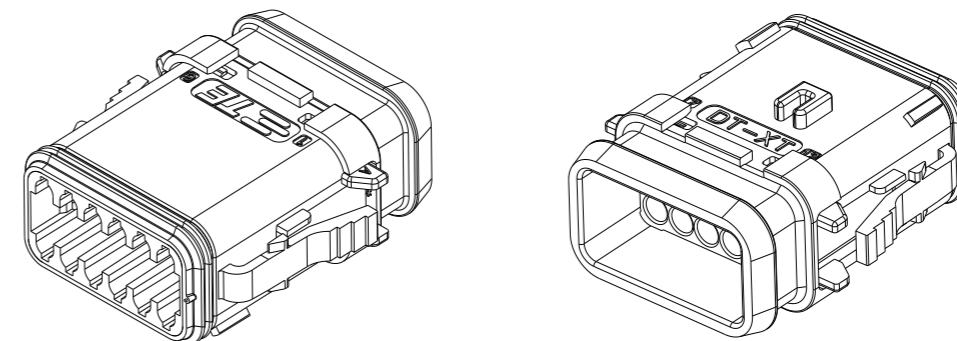

DATE CODE: X XX XX
 X- DAY: 1- 7
 XX- WEEK: 01 - 52
 XX- YEAR: 00 - 99
 # MACHINE NO. 1

EXAMPLE: 11315 = DAY 1, WEEK 13, YEAR 15
 i.e. 23rd OF MARCH 2015

DETAIL B
 SCALE 2:1

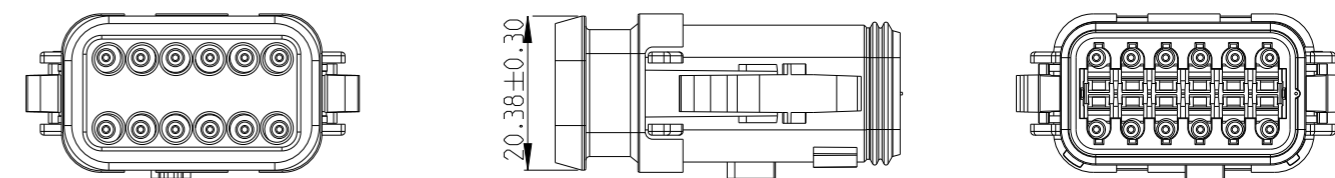
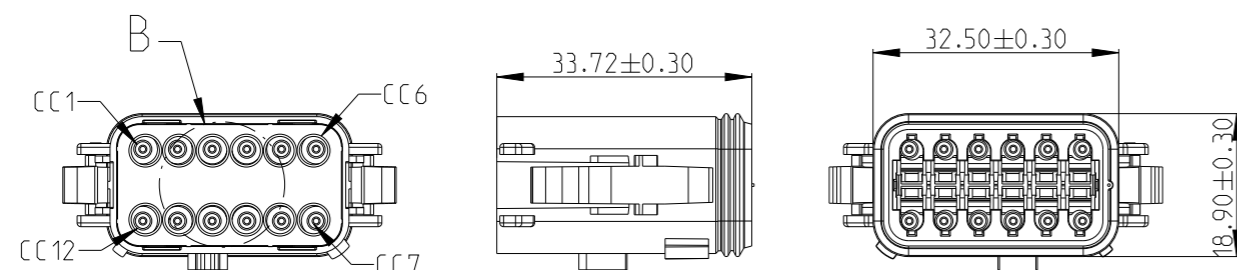
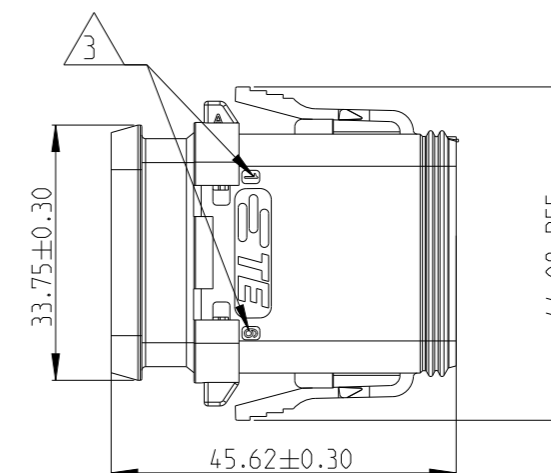

1. THIS PLUG MATES WITH RECEP ASSEMBLY PN X-2600042-X, WEDGE LOCK PN W12S.

2. MATERIAL

PLUG HOUSING: NYLON GF30, PLUG SEAL: SILICONE RUBBER, RED
 BACK SEAL: SILICONE RUBBER
 BACK COVER: NYLON GF30, BLACK
 HEATSHRINK HOUSING: NYLON GF30, BLACK

3 CIRCUIT IDENTIFICATION

4. JACKET RANGE LARGE = Ø2.23mm TO 3.68mm (SEAL COLOUR: LIGHT BLUE)
 JACKET RANGE SMALL = Ø1.20mm TO 3.05mm (SEAL COLOUR: BURNT ORANGE)

5. SEE SHEET3 FOR FINAL PART NUMBER DESIGNATION

THIS DRAWING IS A CONTROLLED DOCUMENT.

DIMENSIONS:	TOLERANCES UNLESS OTHERWISE SPECIFIED:
mm	
	0 PLC ±
	1 PLC ±
	2 PLC ±
	3 PLC ±
	4 PLC ±
	ANGLES ±
MATERIAL	FINISH
-	-
-	-

DWN	J. SHANG	20JUN2020
CHK	E. JIANG	20JUN2020
APVD	I. YIN	20JUN2020
PRODUCT SPEC	108-160026	
APPLICATION SPEC	114-160017	
WEIGHT	-	
CUSTOMER DRAWING		

		NAME		12CCT DT-XT PLUG CONNECTOR	
		SIZE	CAGE CODE	DRAWING NO	RESTRICTED TO
A3	00779	C-2600043	-		
SCALE		1:1	SHEET		1 OF 3
REV		A3			

REVISIONS

P	LTR	DESCRIPTION	DATE	DWN	APVD
		SEE SHEET 1			

KEYING OPTION A

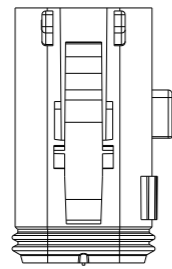

KEYING OPTION B

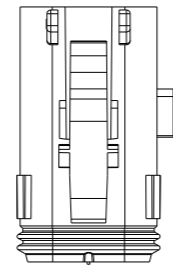

KEYING OPTION C

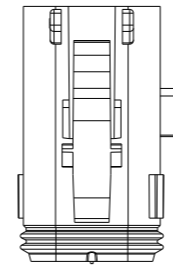

KEYING OPTION D

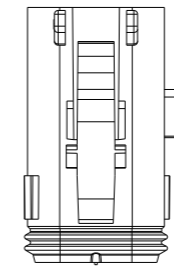

KEYING OPTION E

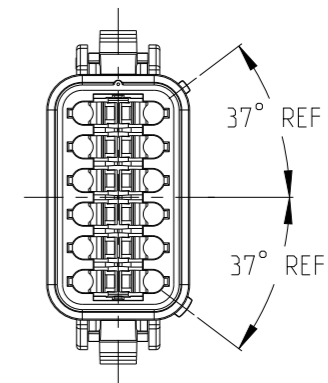
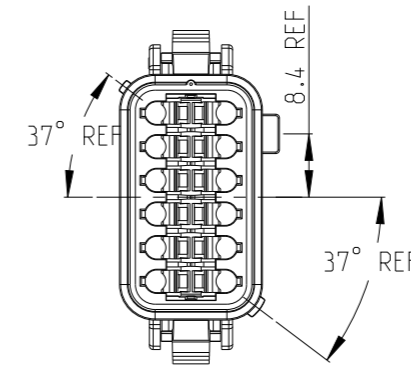
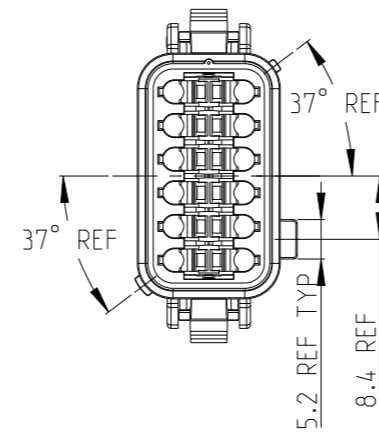
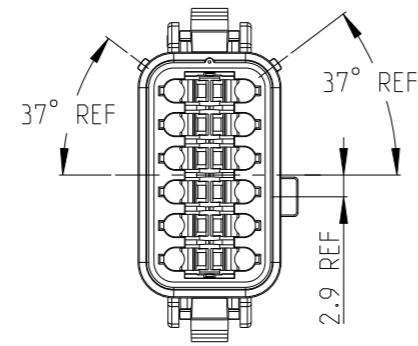
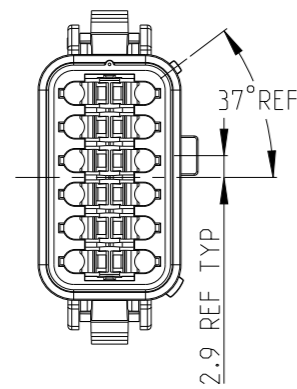
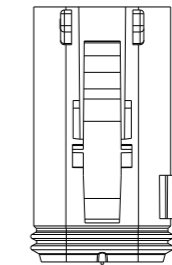

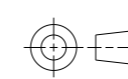
THIS DRAWING IS A CONTROLLED DOCUMENT.		DWN J. SHANG 20JUN2020	 TE Connectivity				
		CHK E. JIANG 20JUN2020					
		APVD L. YIN 20JUN2020					
		PRODUCT SPEC 108-160026					
DIMENSIONS: mm		TOLERANCES UNLESS OTHERWISE SPECIFIED:		NAME 12CCT DT-XT PLUG CONNECTOR			
		0 PLC	±	SIZE	CAGE CODE	DRAWING NO	RESTRICTED TO
		1 PLC	±	A3	00779	C=2600043	-
		2 PLC	±	SCALE 1:1 SHEET 2 OF 3 REV A3			
		3 PLC	±	CUSTOMER DRAWING			
MATERIAL		4 PLC	±				
		ANGLES	±				
		FINISH	-				
			-				

REVISIONS

P	LTR	DESCRIPTION	DATE	DWN	APVD
		SEE SHEET 1			

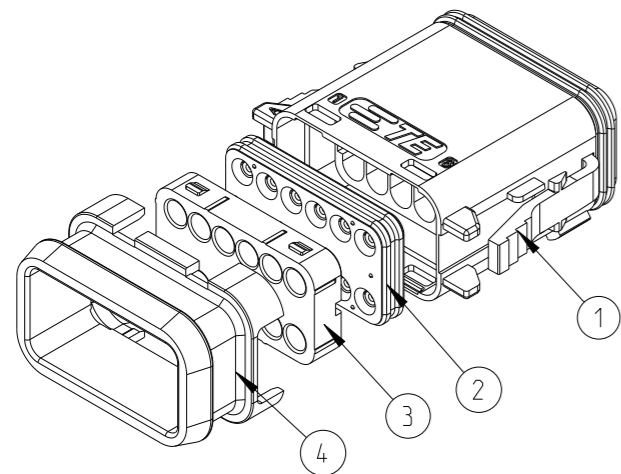

2- -4	934456652	-	17.47	-	-	-	-	-	1	-	1	1	1	
2- -3	934456647	-	17.47	-	-	-	-	1	-	-	1	1	1	
2- -2	934456633	-	17.47	-	-	-	1	-	-	-	1	1	1	
2- -1	934456621	-	17.47	-	-	1	-	-	-	-	1	1	1	
2- -0	934456611	-	17.47	-	1	-	-	-	-	-	1	1	1	
1- -9	934456612	-	17.47	1	-	-	-	-	-	-	1	1	1	
1- -8	934456552	-	17.47	-	-	-	-	-	1	1	-	1	1	
1- -7	934456547	-	17.47	-	-	-	-	1	-	1	-	1	1	
1- -6	934456533	-	17.47	-	-	-	1	-	-	1	-	1	1	
1- -5	934456521	-	17.47	-	-	-	1	-	-	1	-	1	1	
1- -4	934456511	-	17.47	-	1	-	-	-	-	1	-	1	1	
1- -3	934456512	-	17.47	1	-	-	-	-	-	1	-	1	1	
1- -2	934456252	-	14.52	-	-	-	-	-	1	-	1	1	-	
1- -1	934456247	-	14.52	-	-	-	-	1	-	-	1	1	-	
1- -0	934456233	-	14.52	-	-	-	1	-	-	-	1	1	-	
-9	934456221	-	14.52	-	-	1	-	-	-	-	1	1	-	
-8	934456211	-	14.52	-	1	-	-	-	-	-	1	1	-	
-7	934456212	-	14.52	1	-	-	-	-	-	-	1	1	-	
-6	934456152	-	14.52	-	-	-	-	-	1	1	-	1	-	
-5	934456147	-	14.52	-	-	-	-	1	-	1	-	1	-	
-4	934456133	-	14.52	-	-	-	1	-	-	1	-	1	-	
-3	934456121	-	14.52	-	-	1	-	-	-	1	-	1	-	
-2	934456111	-	14.52	-	1	-	-	-	-	1	-	1	-	
-1	934456112	-	14.52	1	-	-	-	-	-	-	1	1	-	
TE PN	ALIAS PN	REVISION OF EACH ASSY NO.	WEIGHT OF EACH ASSY(g)	COLOR	GREY	BLACK	BLACK	GREEN	BROWN	GREY	BURNT ORANGE	LIGHT BLUE	BLACK	BLACK
				KEYING	A	A	B	C	D	E	-	-	-	-
				MATERIAL	NYLON GF30	NYLON GF30	NYLON GF30	NYLON GF30	NYLON GF30	NYLON GF30	SILICONE RUBBER	SILICONE RUBBER	NYLON GF30	NYLON GF30
				DESCRIPTION	PLUG HOUSING						BACK SEAL SMALL	BACK SEAL LARGE	BACK COVER	HEATSHRINK HOUSING
				ITEM NO	1						2		3	4

THIS DRAWING IS A CONTROLLED DOCUMENT.

DWN J.SHANG 20JUN2020

CHK E.JIANG 20JUN2020

APVD L.YIN 20JUN2020

NAME 12CCT DT-XT PLUG CONNECTOR



DIMENSIONS:

mm

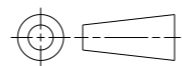

TOLERANCES UNLESS OTHERWISE SPECIFIED:

- 0 PLC ±
- 1 PLC ±
- 2 PLC ±
- 3 PLC ±
- 4 PLC ±
- ANGLES ±
- FINISH -

MATERIAL -

PRODUCT SPEC 108-160026

APPLICATION SPEC 114-160017

WEIGHT -

SIZE CAGE CODE DRAWING NO RESTRICTED TO

A3 00779 C=2600043

CUSTOMER DRAWING

SCALE 1:1 SHEET 3 OF 3 REV A3