

Jun.1.2019 Copyright 2019 HIROSE ELECTRIC CO., LTD. All Rights Reserved.
 In case of consideration for using Automotive equipment / device which demand high reliability, kindly contact our sales window correspondents.

1		2			3			4		
COUNT	DESCRIPTION OF REVISIONS	BY	CHKD	DATE	COUNT	DESCRIPTION OF REVISIONS	BY	CHKD	DATE	
△					△					
△					△					
△					△					

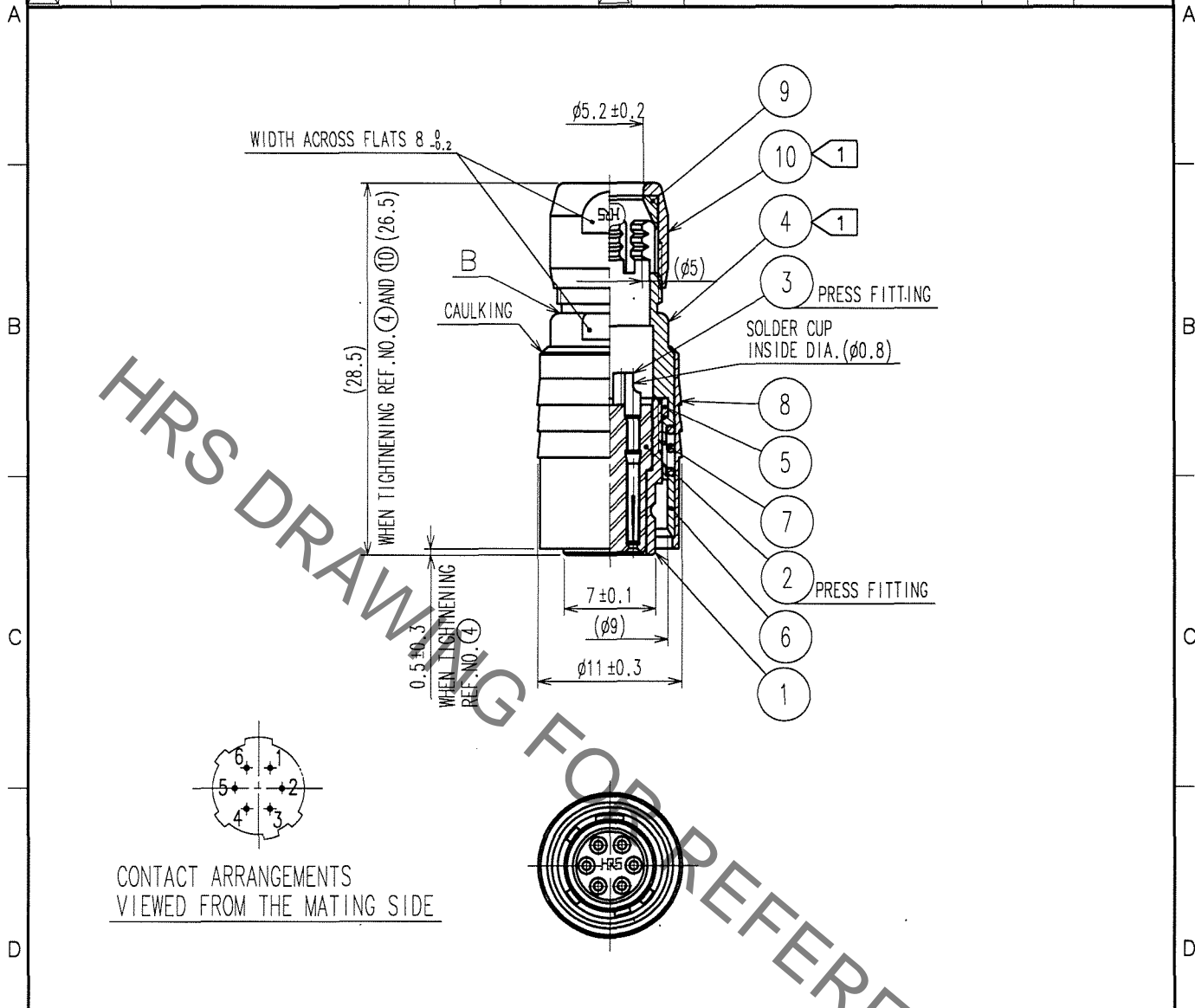

HRS DRAWING FOR REFERENCE

NOTES 1 THE RECOMMENDED CLAMP TORQUE, REF. NO. ④ AND ⑩ : 1.5 N · m.
 REF. NO. ⑩ SHALL BE TIGHTENED BY TORQUE AFTER CLAMPED UNTIL IT TOUCHES THE SURFACE B.
 2 ONE EXAMPLE OF THE ROTATION OF REF. NO. ①, ④ AND ⑩ ARE SHOWN.

5	POLYAMIDE		10	BRASS	MATTE FINISH NICKEL PLATED
4	BRASS	MATTE FINISH NICKEL PLATED	9	POLYAMIDE	
3	BERYLLIUM COPPER	GOLD PLATING 0.2μ m min. NICKEL UNDER PLATING 2μ m min.	8	BRASS	MATTE FINISH NICKEL PLATED
2	POLYAMIDE	(BLUE)	7	STEEL	NICKEL PLATING
1	ZINC ALLOY	MATTE FINISH NICKEL PLATED	6	STAINLESS STEEL	
NO.	MATERIAL	FINISH, REMARKS	NO.	MATERIAL	FINISH, REMARKS

CODE NO. (OLD)	DRAWN	DESIGNED	CHECKED	APPROVED	RELEASED
CL	<i>D. Matsune</i>	<i>D. Matsune</i>	<i>E. Kurii</i>	<i>M. Sato</i>	
	05.11.19	05.11.19	05.11.22	05.11.24	

SACLE 2 : 1 UNITS mm	DRAWING NO. EDC4-007759-73	PART NO. HR10-7P-6S(73)
	HRS HIROSE ELECTRIC CO., LTD.	CODE NO. CL110-0024-4-73

TO
R