

(4X) SNAP-IN POLYCARBONATE HINGE KNUCKLE

FIP POLYURETHANE GASKET

MATERIAL:
 BOX: INJECTION POLYCARBONATE
 STANDARD COVER: INJECTION POLYCARBONATE
 CLEAR COVER: INJECTION POLYCARBONATE

SECTION D-D

(4X) POLYCARBONATE FEET

(4X) #10-32 BRASS INSERTS, 316 STAINLESS STEEL FLANGE AND FEET SCREWS

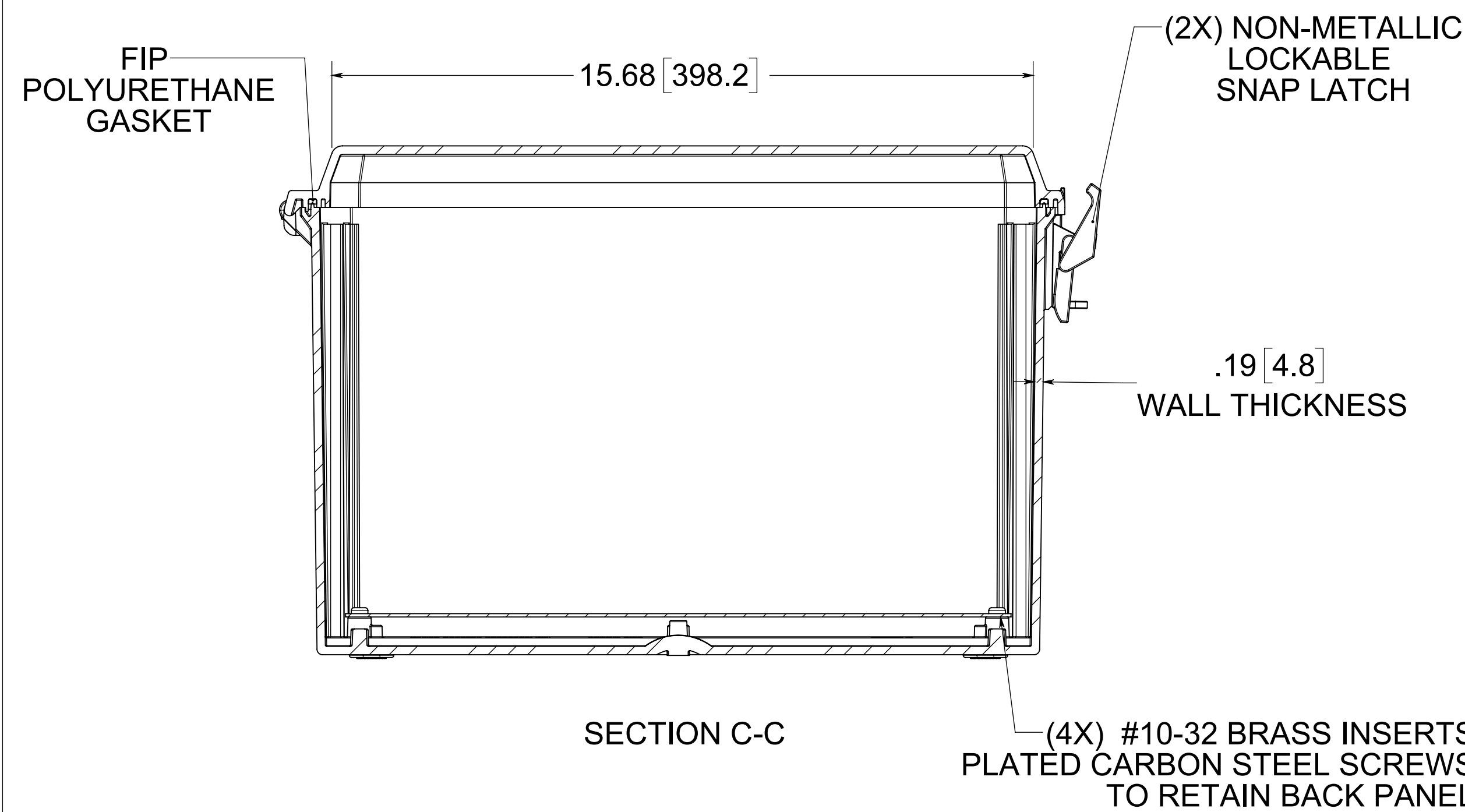

SECTION C-C

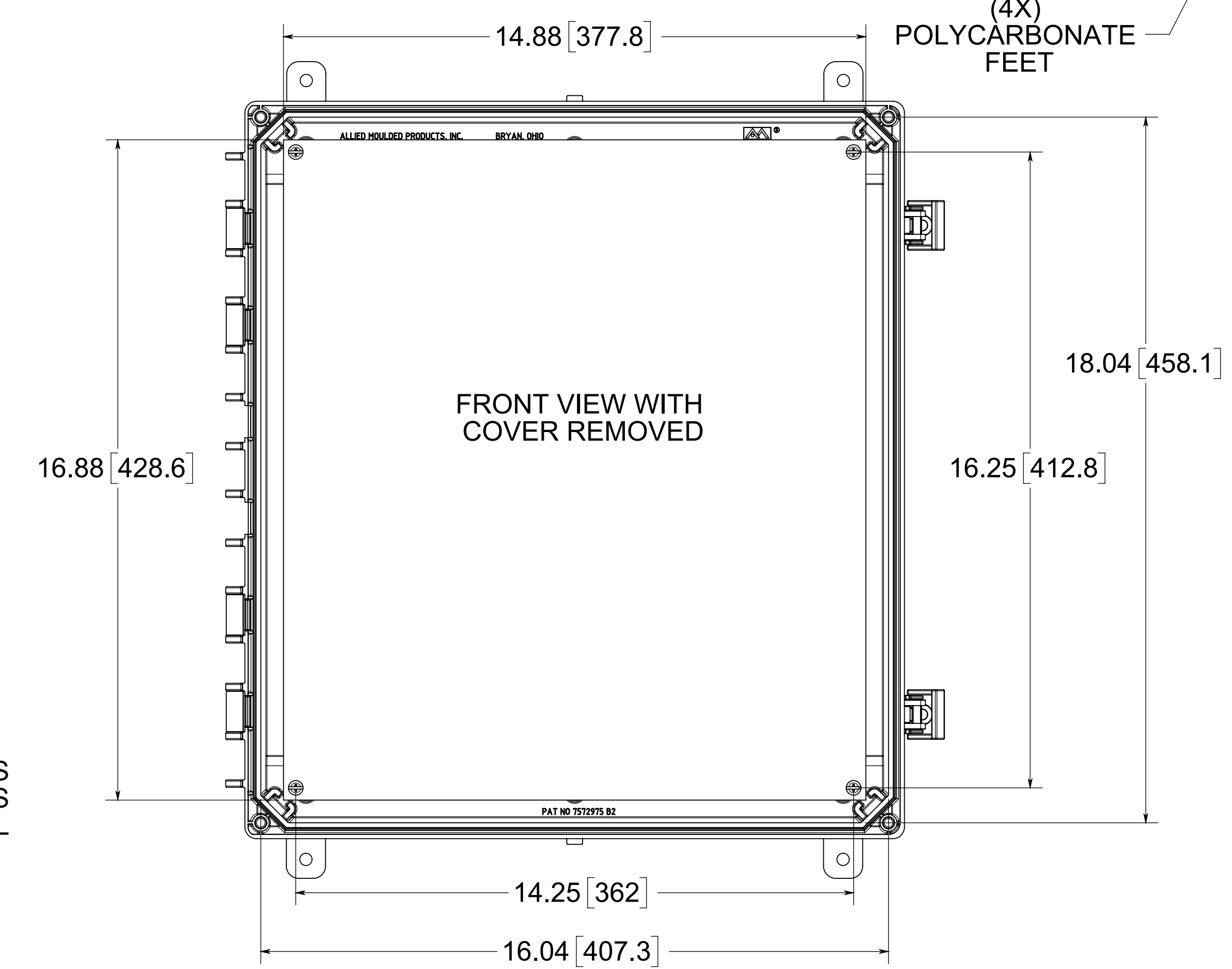

FRONT VIEW WITH COVER REMOVED

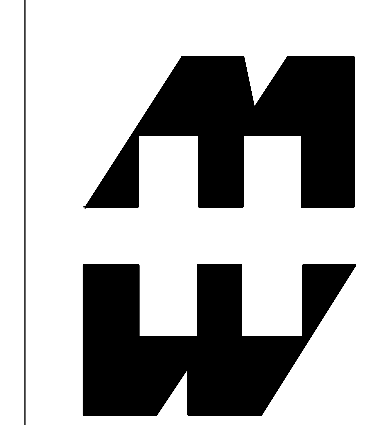

PART No. PCJ181610NL
 for more information visit www.hammfg.com
 Data subject to change without notice
 Drawing Not to Scale