

## 1200 BTU/H Indoor Air Conditioner *DTS Series*

Type 12, Side Mounting



### Description

- Designed for side mounting on any enclosure surface where hot spot cooling or low capacity cooling is required.
- Compact design uses minimal surface area.
- Closed loop cooling ensures clean enclosure air is recirculated without ever mixing with contaminated ambient air.

### Standards

- Maintains enclosure's NEMA 12 rating
- IP 54
- UR, cUR and CE

### Features

- R134a refrigerant.
- Thermostat control.
- Continuous air circulation from high capacity fans.
- EMI/RFI suppression meets CE.
- Line cord with plug (115 V).
- Washable filter mat protected within an easily removable grill.
- Gasket, mounting kit and template for enclosure cutout and drilling are included.
- Condensate drain hose and clamp provided.
- Exterior case easily removable for field service.
- Q Mount allows unit to hang in place for easy installation.

### Accessories

- Gasket Kits
- Condensate Bottle

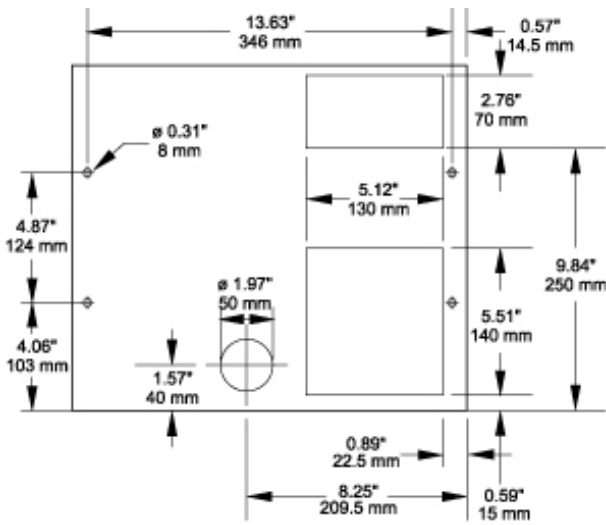

**Drilling Template**

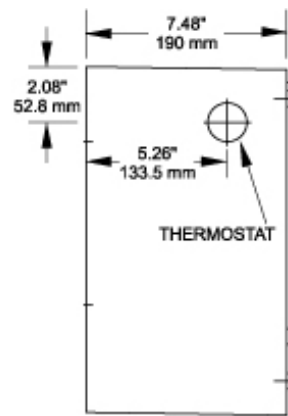

**Left Side View**

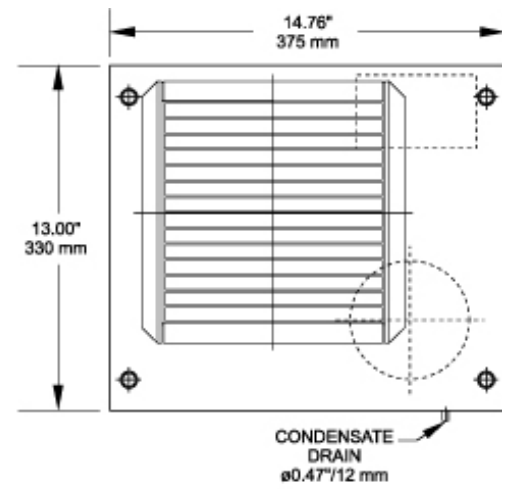

**Front View**

Part No.	Ship Wt. lbs
DTS1200A115LG	42
DTS1200A230LG	42

Electrical Data	DTS1200A115	DTS1200A230LG
Rated Voltage	115 V 60 Hz	230 V 50/60 Hz
	110 v 50 Hz	
Range of Operation	103-127 V	207-253 V
Power Consumption	200 W	200 W
Running Amps	2.2 A	1.3/2.5 A
Starting Current	15.7 A	9.5/13.0 A
Line Cord	With Plug	Without Plug

Refrigeration Data	
Rated Capacity	1,200 BTU/H (350 Watts)
Type of Refrigerant	R134a
Refrigerant Charge	280 g
Adjustable Thermostat	Factory setting +95°F (+35°C)
Max. Ambient Air Temp.	+125°F (+52°C)
Min. Ambient Air Temp.	+46°F (+8°C)
Air Capacity (unrestricted)	Internal Circulation 106 CFM
	External Circulation 230 CFM
Condensation Discharge	Direct via tube
Filter Mat	150 g/m <sup>2</sup>
Db Noise Level	<62 dB (A)
Unit Weight	40 lbs (18 kg)
Exterior Case	Galvanized sheet metal
Finish	RAL7035 light grey finish
NEMA Rating	Enclosures IP 54/NEMA 12

*Data subject to change without notice*