

Part Number	Description
XV46D30K	30A, 420 Vac

Part Number Explanation

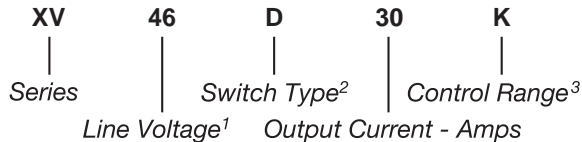

NOTES

- 1) Line Voltage (nominal): 46 = 420 Vac
- 2) Switch Type: D = Zero-cross turn-on
- 3) Control Range: K = 20–30 Vdc, *C = 12 Vdc also available

MECHANICAL SPECIFICATION

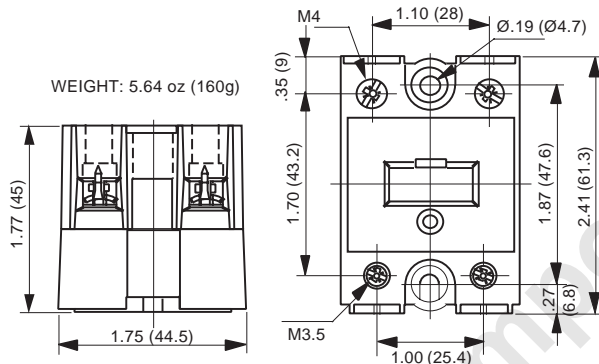

Figure 1 – XV relay; dimensions in inches (mm)

INPUT (CONTROL) SPECIFICATION

	Min	Max	Units
Control Range*	20	30	Vdc
Input Current Range	31	41	mAdc
Must Turn-Off Voltage		10	Vdc
Input Resistance (Typical)		640	Ohms
Reverse Voltage Protection		30	Vdc
Control Frequency		1	Hz

TYPICAL APPLICATION

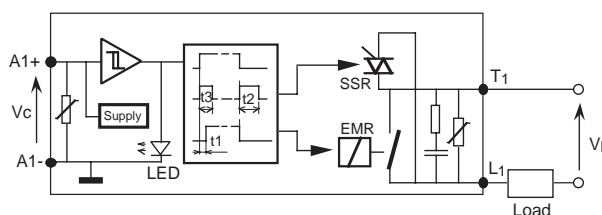

Figure 2 – XV relay



FEATURES/BENEFITS

- Industry standard package
- Combines the best of solid-state and electromechanical relays
- Tight zero-cross window for low EMI
- Control LED
- Internal output protection
- High immunity to surges

DESCRIPTION

The Series XV relay combines the best of solid-state and electromechanical technology. The relay is designed in a touch-proof hockey-puck package. The XV relay switches current up to 30A without a heat sink. Visual control status is provided as a standard. Elimination of the heat sink conserves space and makes the XV ideal for numerous applications.

APPLICATIONS

- Interface applications
- Heating Control
- Light/Lamp control
- Contactor driver
- Fan speed control
- HVAC controls

APPROVALS

Model XV46D30K is UL recognized.
UL File Number: E128555.

CONTROL CHARACTERISTIC

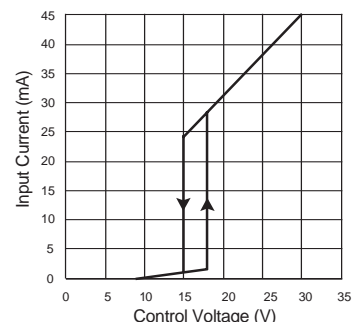

Figure 3 – XV relay

OUTPUT (LOAD) SPECIFICATION

	Min	Max	Unit
Operating Range	12	420	Vrms
Peak Voltage		800	Vpeak
Load Current Range	0.1	30	Arms
Motor Load Current		7.5	Arms
Maximum Surge Current Rating (Non-Repetitive) (See Figure 4)	240	Apeak	
On-State Voltage Drop		0.3	V
Zero-Cross Window (Typical)		±12	V
Off-State Leakage Current (60Hz)		2	mA
Turn-On Time (60Hz)		12	ms
Turn-Off Time (60Hz)		20	ms
Off-State dv/dt		500	V/μs
Maximum di/dt (Non-repetitive)		50	A/μs
Operating Frequency	40	440	Hz
I ² t for fuse matching (<8.3ms)		288	A ² S

ENVIRONMENTAL SPECIFICATION

	Min	Max	Unit
Operating Temperature	-40	90	°C
Storage Temperature	-40	100	°C
Input-Output Isolation		4000	Vrms
Output-Case Isolation		4000	V
Life Expectancy		See Figure 5	

SURGE CURRENT

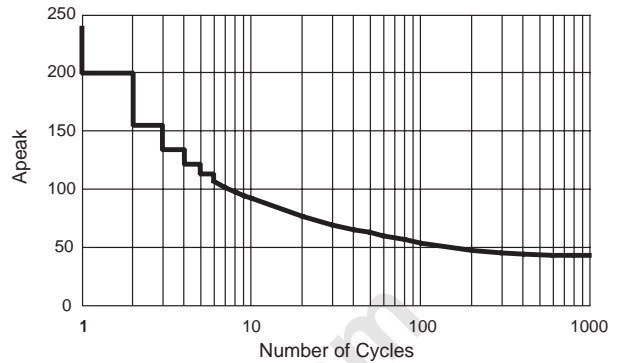

Figure 4 – XV relay

LIFETIME EXPECTANCY

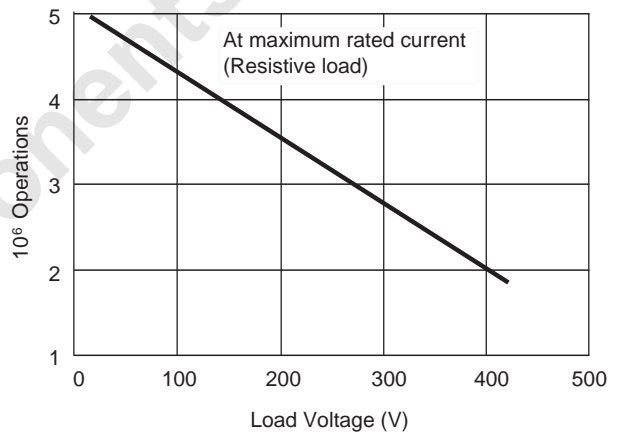

Figure 5 – XV relay

- NOTES:
1. Electrical Specifications at 25°C unless otherwise specified.
 2. For 800Hz applications, contact factory.
 3. For additional/custom options, contact factory.