

AS85049/24 and MS3188C 90° EMI/RFI Non-Environmental Backshell



AS85049

B

CONNECTOR DESIGNATOR:	
A	AS50151 Series AS34001
	MIL-DTL-26482 Series II
	AS81703 Series III
	MIL-DTL-83723 Series I & III
	40M39569, DEF 5326-3, EN 2997
	EN 3646, ESC 10, ESC 11, LN 29504
	NFC93422 Series HE302 PAN 6432-1, PAN 6432-2, PATT 602

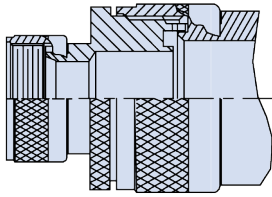

STYLE 2

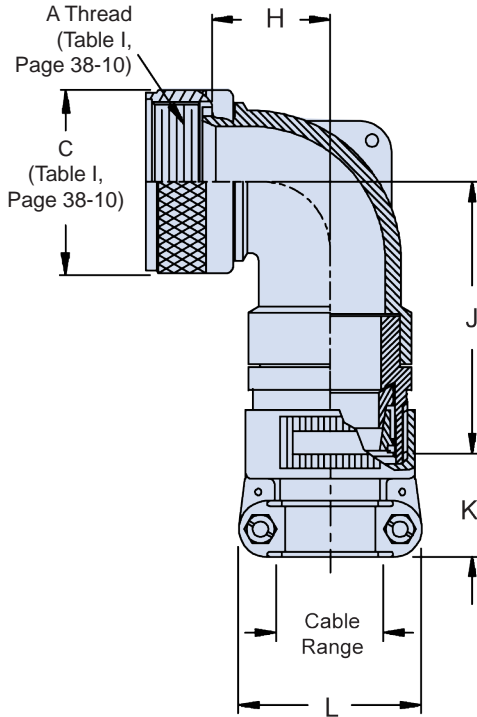

Basic Part Number Dash Number (Table II)

M85049/24 - 21 N

Finish / Material
B = Black Cadmium / Stainless Steel
N = Electroless Nickel / Aluminum
S = Passivated / Stainless Steel
W = 1,000 Hr. Cadmium Olive Drab over Electroless Nickel / Aluminum
X = Aluminum, Nickel Fluorocarbon Polymer
Z = Aluminum, Zinc-Nickel, Black
XS = Stainless Steel, Nickel Fluorocarbon Polymer
ZS = Stainless Steel, Zinc-Nickel, Black

Superseded Part Number

MS3188C 21 N

Basic Part No.	Dash No.
----------------	----------

Finish (Material is Aluminum Only)

A = Cadmium Olive Drab over Nickel
C = Cadmium Olive Drab
N = Electroless Nickel

TABLE II: Dash Number, Cable Range and Dimensions								
Dash No.	Shell Size	H Max	J Max	K Ref.	L Max	Cable Range		M85049/42 Ref.
						Min	Max	
1	03	.698 (17.7)	1.862 (47.3)	1.027 (26.1)	.957 (24.3)	.125 (3.2)	.250 (6.4)	04
2	03	1.448 (36.8)	1.382 (35.1)	1.027 (26.1)	1.145 (29.1)	.250 (6.4)	.437 (11.1)	04
3	08	.603 (15.3)	1.262 (32.1)	1.027 (26.1)	.957 (24.3)	.125 (3.2)	.250 (6.4)	04
4	10	.698 (17.7)	1.982 (50.3)	1.027 (26.1)	.957 (24.3)	.125 (3.2)	.312 (7.9)	04
5	10	.698 (17.7)	1.382 (35.1)	1.027 (26.1)	1.145 (29.1)	.250 (6.4)	.375 (9.5)	06
6	12	.703 (17.9)	2.002 (50.9)	1.027 (26.1)	.957 (24.3)	.125 (3.2)	.312 (7.9)	04
7	12	.703 (17.9)	2.002 (50.9)	1.027 (26.1)	1.145 (29.1)	.250 (6.4)	.437 (11.1)	06
8	12	.703 (17.9)	1.397 (35.5)	1.027 (26.1)	1.332 (33.8)	.350 (8.9)	.500 (12.7)	10
9	14	.803 (20.4)	2.072 (52.6)	1.027 (26.1)	1.145 (29.1)	.250 (6.4)	.437 (11.1)	06
10	14	.803 (20.4)	1.717 (43.6)	1.027 (26.1)	1.332 (33.8)	.350 (8.9)	.575 (14.6)	10
11	16	.988 (25.1)	2.162 (54.9)	1.027 (26.1)	1.145 (29.1)	.250 (6.4)	.437 (11.1)	06
12	16	.988 (25.1)	1.807 (45.9)	1.059 (26.9)	1.551 (39.4)	.500 (12.7)	.700 (17.8)	12
13	18	1.078 (27.4)	2.332 (59.2)	1.027 (26.1)	1.332 (33.8)	.350 (8.9)	.625 (15.9)	10
14	18	1.078 (27.4)	1.982 (50.3)	1.156 (29.4)	1.770 (45.0)	.625 (15.9)	.779 (19.8)	16
15	20	1.078 (27.4)	2.332 (59.2)	1.027 (26.1)	1.332 (33.8)	.350 (8.9)	.625 (15.9)	10
16	20	1.079 (27.4)	1.982 (50.3)	1.156 (29.4)	1.770 (45.0)	.625 (15.9)	.904 (23.0)	16
17	22	1.228 (31.2)	2.442 (62.0)	1.059 (26.9)	1.551 (39.4)	.500 (12.7)	.750 (19.1)	12
18	22	1.228 (31.2)	2.087 (53.0)	1.375 (34.9)	2.113 (53.7)	.875 (22.2)	1.029 (26.1)	20
19	24	1.228 (31.2)	2.442 (62.0)	1.059 (26.9)	1.551 (39.4)	.500 (12.7)	.750 (19.1)	12
20	24	1.228 (31.2)	2.087 (53.0)	1.375 (34.9)	2.113 (53.7)	.875 (22.2)	1.144 (29.1)	20
21	28	1.328 (33.7)	2.612 (66.3)	1.156 (33.7)	1.770 (45.0)	.625 (15.9)	.937 (23.8)	16

Continued on Page B-46 • Refer to the Mil-Spec for Complete Dimensions

Dimensions in inches (millimeters) and are subject to change without notice.