

DASH NO	CONNECTOR SHELL SIZE				A THREAD CLASS 2B	B DIA MAX	C DIA ±.005 3	D MAX	E CABLE ENTRY		F MAX	G MAX	H MAX	APPROX WEIGHT (GRAMS) ALUM	APPROX WEIGHT (GRAMS) SST
	MIL-C-83723 SERIES 1 & 3	MIL-C-5015 MS3400 SERIES	MIL-C-81703 SERIES 3	MIL-C-26482 SERIES 2					4						
	CLOSED	OPEN													
08	8	8S		8	1/2 -20 UNF	.617	.361	.781	.125	.204	.808	.752	.093	10.5	-
10	10	10S,10SL		10	5/8 -24 UNEF	.734	.437	.824	.187	.286	.867	.832	.093	11.8	-
12	12	12,12S	7	12	3/4 -20 UNEF	.858	.584	.979	.291	.416	.929	.988	.125	13.9	-
14	14	14,14S	12	14	7/8 -20 UNEF	.984	.678	1.039	.351	.476	.992	1.046	.125	17.6	35.6
16	16	16,16S	19	16	1 -20 UNEF	1.112	.809	1.188	.501	.625	1.056	1.319	.188	20.0	-
18	18	18	27	18	1 1/16-18 UNEF	1.198	.885	1.300	.518	.706	1.233	1.451	.188	28.2	54.7
20	20	20	37	20	1 3/16-18 UNEF	1.323	1.005	1.425	.581	.831	1.296	1.551	.188	30.9	-
22	22	22		22	1 5/16-18 UNEF	1.448	1.142	1.550	.644	.956	1.358	1.653	.188	35.1	69.9
24	24	24		24	1 7/16-18 UNEF	1.573	1.278	1.675	.706	1.081	1.420	1.775	.188	39.1	85.3
28		28			1 3/4 -18 UNS	1.969	1.532	1.813	.750	1.187	1.634	2.020	.188	-	120.2

SYM.	DESCRIPTION	DATE	APPROVED
A	REVISED PER DCN 04081	11/04/81	J.B.
B	REVISED PER DCN 04811	06/11/84	C.S.
C	REVISED PER DCN 06172	03/19/87	J.S.
D	REVISED PER DCN 06769	11/18/87	J.S.
E	REDRAWN & REVISED PER DCN 08542	02/20/90	T.L.
F	REVISED PER DCN 29019	02/19/08	T.L.
G	REVISED PER DCN 52732	10/27/14	N.D.

SYM	FINISH DESCRIPTION
B	CADMIUM PLATE/OLIVE DRAB
M	ELECTROLESS NICKEL
N	CADMIUM PLATE/OLIVE DRAB OVER NICKEL PLATE
NF	CAD/O. D. OVER ELECTROLESS NICKEL (1000 HOUR SALT SPRAY)
OMIT	BLACK ANODIZE
P	NICKEL PLATE, PER QQ-N-290

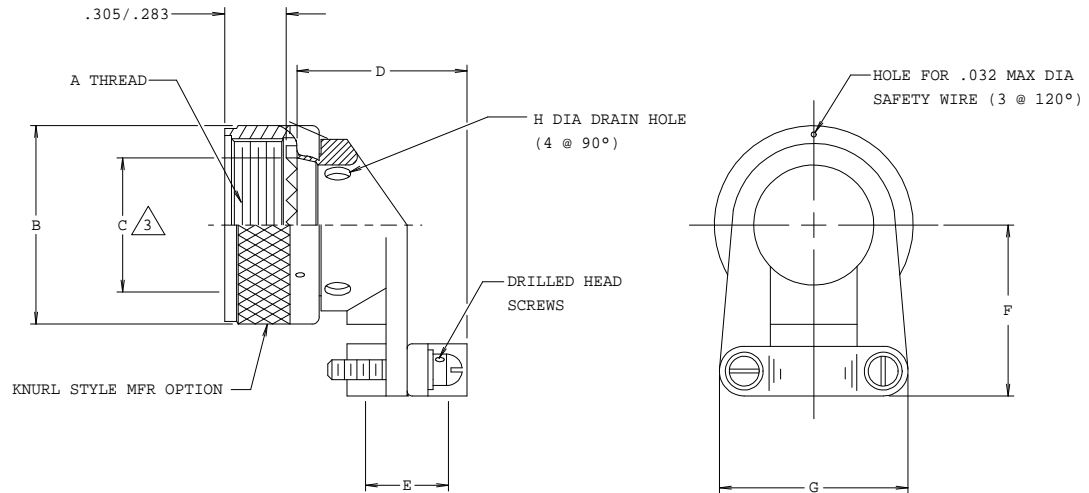

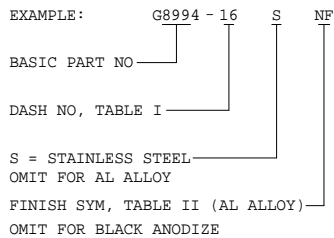

PART NUMBER DEVELOPMENT



NOTES:

- ASSEMBLY IDENTIFIED WITH MANUFACTURER'S NAME AND P/N, SPACE PERMITTING.
- GLENNAIR 600 SERIES BACKSHELL ASSEMBLY TOOLS ARE RECOMMENDED FOR ASSEMBLY AND INSTALLATION.
- INTERFACE PER BOEING SPECS BACC10HE & BACC10HG.
- CABLE ENTRY IS DEFINED AS THE ACCOMMODATION ENTRY FOR THE WIRE BUNDLE OR CABLE. DIMENSIONS ARE NOT INTENDED FOR INSPECTION CRITERIA.
- MATERIAL/FINISH:
CLAMP BODY, SADDLES, COUPLING NUT - AL ALLOY/SEE TABLE II (POROSITY PERMISSIBLE IN INSIDE DIAMETER) - OR 300 SERIES STAINLESS STEEL/PASSIVATE
CLAMP HARDWARE - CRES/PASSIVATE

THIS COPYRIGHTED DOCUMENT IS THE PROPERTY OF GLENNAIR, INC. AND IS FURNISHED ON THE CONDITION THAT IT IS NOT TO BE DISCLOSED, REPRODUCED IN WHOLE OR IN PART, OR USED TO SOLICIT QUOTATIONS FROM COMPETITIVE SOURCES, OR USED FOR MANUFACTURE BY ANYONE OTHER THAN GLENNAIR, INC. WITHOUT WRITTEN PERMISSION FROM GLENNAIR, INC. THE INFORMATION HEREIN HAS BEEN DEVELOPED AT GLENNAIR'S EXPENSE AND MAY BE USED FOR ENGINEERING EVALUATION AND INCORPORATION INTO TECHNICAL SPECIFICATIONS AND OTHER DOCUMENTS WHICH SPECIFY PROCUREMENT OF PRODUCTS FROM GLENNAIR, INC.

UNLESS OTHERWISE SPECIFIED DIMENSIONS ARE IN INCHES TOLERANCES:	DRAWN	T. LE	02/20/90	GLENNAIR, INC. CAD 1990 [®]
	CHECK	G. BURGE	02/20/90	
	ENGR	P. OAKES	02/20/90	1211 AIR WAY - GLENDALE - CALIFORNIA 91201
FRACTIONS ± 1/16	 APPROVED			STRAIN RELIEF, 90°, FOR CONNECTORS PER TABLE I
DECIMALS .XX ±.03 .XXX ±.015				
ANGLES ± 2°	 APPROVED			CODE IDENT. NO.
DO NOT SCALE THIS DRAWING				RELEASE DATE
B/F 90-4235 P/C 62	ORIGINAL RELEASE DATE	10/23/81	6324	G8994
	NON REPARABLE COMMERCIAL ITEM		SCALE	N/A
			WEIGHT	N/A
			SHEET	1 OF 1
			REV.	G