

WE RECOMMEND THESE CONNECTORS FOR OPTIMAL SERVICE LEVEL



- SHORT LEAD-TIMES
- LOW MOQs
- QUICK SAMPLING
- AVAILABLE AT DISTRIBUTION

<b>Preferred Part</b>	
71918-110LF	71918-140LF
71918-114LF	71918-150LF
71918-116LF	71918-164LF
71918-120LF	71918-210LF
71918-126LF	71918-214LF
71918-134LF	71918-240LF

LATCHING  
SEE SHEET 2

TOTAL NB OF POSITION  
SEE SHEET 2

RoHS COMPATIBLE, SEE NOTE 10

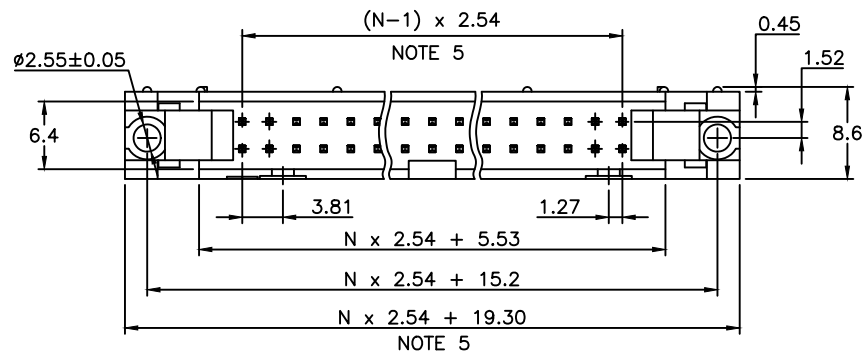

NOTES:

- HOUSING MATERIAL: GLASS FILLED THERMOPLASTIC UL94V-0  
= STANDARD COLOR GREY  
B = OPTION COLOR BLACK
- PIN MATERIAL : PHOSPHOR BRONZE
- PRODUCT PACKAGED IN TUBES
- 40N MIN LATCH RETENTION FORCE AT FIRST EXTRACTION
- TO DETERMINE DIMENSIONS :  
N = NUMBER OF POSITIONS PER ROW  
EXAMPLE : 8 POS N x 2.54 = 20.32mm
- NO CENTRAL SLOT ON POSITIONS 6 & 8
- NO LEFT POLARIZATION ON POSITIONS 06, 08, 10, 14.
- NO GROOVE ON POSITIONS 06, 08, 10, 14, 30, 34
- 4.5mm SOLDER TAIL  
ORDER 71918-4XX (WITH STANDARD LATCH ONLY)
- RoHS COMPATIBLE PRODUCT SPECIFICATIONS
  - PLATING:  
- "LF" MEANS THE PRODUCT IS LEAD-FREE, 2µm MINIMUM MATTE TIN OVER 1.27µm MINIMUM NICKEL UNDERPLATE.
  - MANUFACTURING PROCESS COMPATIBILITY  
- THE HOUSING WILL WITHSTAND EXPOSURE TO 260°C ±5°C SOLDER BATH TEMPERATURE FOR 5 SECONDS IN A WAVE SOLDER APPLICATION WITH A 1.6mm MIN THICK CIRCUIT BOARD.
  - LABELING:  
- MEETS PACKAGING SPECS AS PER GS-14-920
  - LEGAL STATEMENT: SEE GS-47-0004.
- COSMETIC CRACKS ALLOWED IN THIS AREA
- THIS PART SERIES IS NOT INITIALLY INTENDED FOR AUTOMOTIVE APPLICATIONS. ADDITIONAL FEES ARE CHARGEABLE FOR ANY ADDITIONAL QUALIFICATION AND TEST REPORTS PERFORMED OUTSIDE THE SCOPE OF THE STANDARD PRODUCT SPECIFICATIONS.
- UNLESS OTHERWISE APPROVED BY AMPHENOL, ALL PARTS AND COMPONENTS ARE DESIGNED & BUILT ACCORDING TO AMPHENOL'S SPECIFICATIONS WHICH ARE SUBJECT TO CHANGE WITHOUT NOTICE.

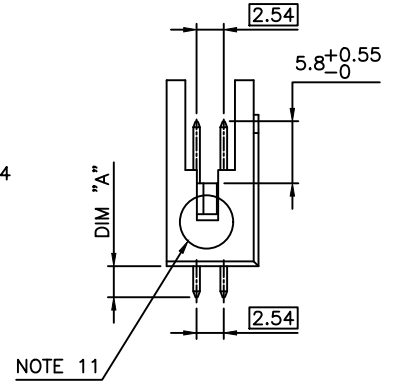
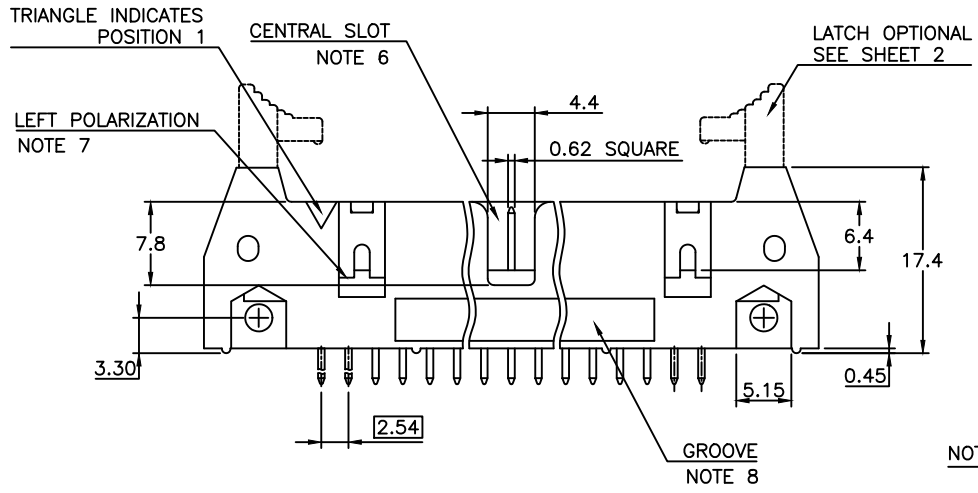

mat'l. code SEE NOTES				surface ISO 1302	tolerance ISO 406 ISO 1101	projection mm	product family QUICKIE	
ltr	ecn no	dr	date	tolerances unless otherwise specified		mm	title	
AG	F-37618	LMU	20.07.09	angles	linear		SHR E L HEADER STR DR TMT	
AH	F-48536	DDE	23.06.19		.X ±0.3	scale 5:1	dwg no	
AJ	F-49169	LMU	23.07.31		.XX ±0.15		sheet 1 of 2	
AK	F-54428	DDE	25.01.24	dr	.XXX ±0.05	size		
AL	F-56516	DDE	25.07.15	engr		A3		
AM	F-57314	DDE	25.09.16	chr		71918		
				appd		type		
						CUSTOMER Drawing		
sheet index	revision sheet	AM	AC					
		1	2					

Amphenol FCI  
FCIconnect.com

Copyright FCI

PRODUCT NUMBER	SIZE	LATCHING AVAILABILITY	MISSING PIN POSITIONS
71918-X06(B)LF	2x3	0/1/2/4/5/6/T	
71918-X08(B)LF	2x4	0/1/2/4/5/6/T	
71918-X10(B)LF	2x5	0/1/2/4/5/6/T	
71918-X14(B)LF	2x7	0/1/2/4/5/6/T	
71918-X16(B)LF	2x8	0/1/2/4/5/6/T	
71918-X18(B)LF	2x9	0/1/2/4/5/6/T	
71918-X20(B)LF	2x10	0/1/2/4/5/6/T	
71918-X26(B)LF	2x13	0/1/2/4/5/6/T	
71918-X27(B)LF	2x13	0/1/2/4/5/6/T	21;22
71918-X28(B)LF	2x13	0/1/2/4/5/6/T	5 to 12
71918-X30(B)LF	2x15	0/1/2/4/5/6/T	
71918-X34(B)LF	2x17	0/1/2/4/5/6/T	
71918-X35(B)LF	2x17	0/1/2/4/5/6/T	2;3
71918-X36(B)LF	2x17	0/1/2/4/5/6/T	11to16 & 19to24
71918-X40(B)LF	2x20	0/1/2/4/5/6/T	
71918-X44(B)LF	2x22	0/1/2/4/5/6/T	
71918-X45(B)LF	2x22	0/1/2/4/5/6/T	9;10;23;24
71918-X50(B)LF	2x25	0/1/2/4/5/6/T	
71918-X51(B)LF	2x25	0/1/2/4/5/6/T	39 to 46
71918-X60(B)LF	2x30	0/1/2/4/5/6/T	
71918-X64(B)LF	2x32	0/1/2/4/5/6/T	

PLATING FOR LATCHING CODE 0/1/2/4/5/6:  
0.76µm GOLD/GXT  
(PdNi WITH GOLD FLASH) ON CONTACT AREA  
2µm MIN MATTE TIN ON TAIL  
UNDERPLATING : 1.27µm Ni MIN

PLATING FOR LATCHING CODE T:  
2µm MIN FULL MATTE TIN ALL OVER  
UNDERPLATING : 1.27µm Ni MIN

LATCHING FEATURES :

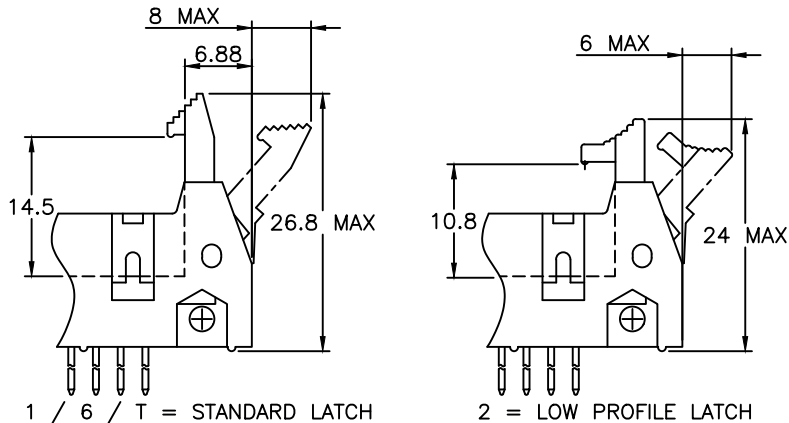

EXTENDED RANGE

PRODUCT NUMBER

71918-YXXZZLF

RoHS COMPATIBLE, SEE NOTE 10  
P = DEDICATED CUSTOMER PART COLOR GREY  
S = SPECIFIC CUSTOMER PLATING OPTION.

COLOR OPTION, SEE NOTE 1  
(AS AVAILABLE)

TOTAL NB OF POSITIONS, SEE ON LEFT

LATCHING

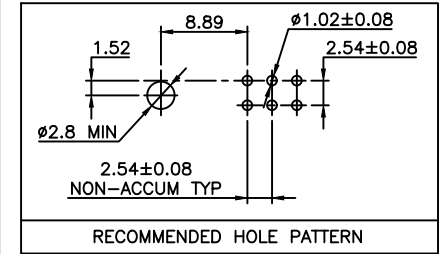

GOLD/GXT PLATING  
SEE ON LEFT

- 0= WITHOUT LATCH WITH DIM "A" 2.9mm
  - 1= STANDARD LATCH WITH DIM "A" 2.9mm
  - 2= LOW PROFILE LATCH WITH DIM "A" 2.9mm
  - 4= STANDARD LATCH WITH DIM "A" 4.5mm (AS AVAILABLE)
  - 5= LOW PROFILE LATCH WITH DIM "A" 3.94mm (AS AVAILABLE)
  - 6= STANDARD LATCH WITH DIM "A" 3.94mm (AS AVAILABLE)
- GXT PLATING

FULL TIN PLATING  
SEE ON LEFT

- T= STANDARD LATCH WITH DIM "A" 2.9mm (AS AVAILABLE)

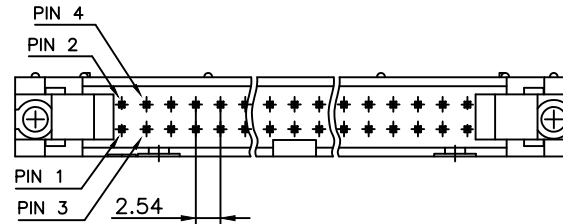

PIN POSITION INDICATION FOR POLARIZED VERSIONS

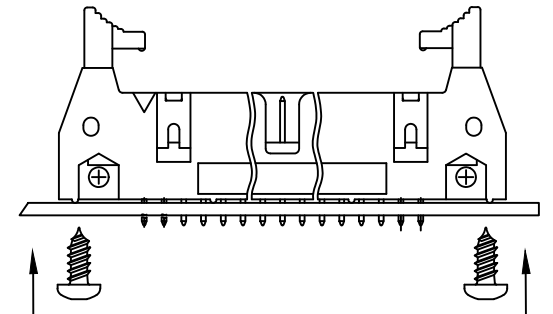

WHEN THE CONNECTORS NEED TO BE FIXED ON THE PCB'S  
THE STAINLESS SCREWS REF TC POZI DIN7981 Ø2.9 X 6.5MM  
TO BE USED

mat'l. code		surface		tolerance		projection		product family	
SEE NOTES		ISO 1302		ISO 406 ISO 1101		mm		QUICKIE	
ltr	ecn no	dr	date	tolerances unless otherwise specified		mm		title	
Y	F-23514	LMU	16.03.14	angles	linear	.X ±0.3		SHR E L HEADER	
AA	F-37618	LMU	20.07.09			.XX ±0.15		STR DR TMT	
AB	F-54428	DDE	25.01.24			.XXX ±0.05		scale 5:1	
AC	F-56516	DDE	25.07.15	dr	D.LEGRAND	01.01.24		dwg no	
				engr	J.COMPAGNON	01.01.24		sheet 2 of 2	
W	B-19091	LMU	14.10.16	chr	JF.NOTTEAU	01.01.24		size	
X	B-20412	BVE	15.03.10	appd	J.COMPAGNON	01.01.24		A3	
sheet		revision						type	
index		sheet						CUSTOMER Drawing	