

PRODUCT NUMBER
SEE PART NO. SCHEME

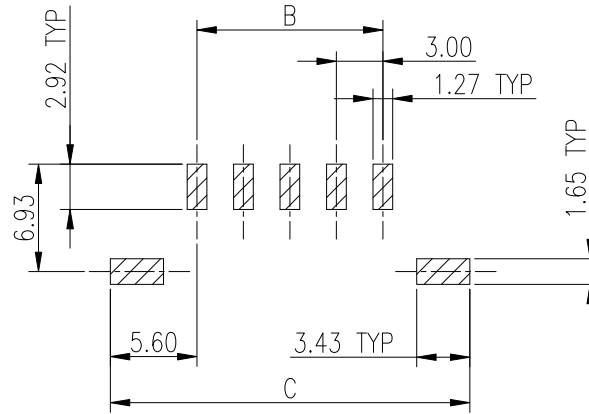
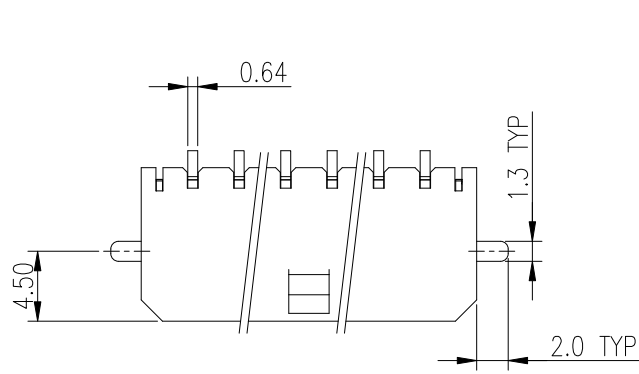

RECOMMENDED P.C.B LAYOUT
(DEFAULT TOLERANCE: ±0.05)

NOTES:

- MATERIALS:
HOUSING: LCP, UL94V-0, COLOR: BLACK
TERMINAL: COPPER ALLOY
HOLD DOWN: COPPER ALLOY
- FINISH:
TERMINAL: SEE PART NO. SCHEME
HOLD DOWN: TIN
UNDER PLATING OF THESE 2 PARTS: NICKEL OVERALL
- PRODUCT SPECIFICATION: GS-12-1177
- PACKAGE SPECIFICATION: GS-14-2359
- THIS PART MATES WITH FCI RECEPTACLE WIRE CONNECTOR 10136653.
- THIS PART IS APPLICABLE FOR REFLOW PROCESS WITH 260°C PEAK TEMPERATURE FOR 5 SECONDS.
- DIMENSION TABLE:

POS.	A	B	C
02	9.65	3.00	14.20
03	12.65	6.00	17.20
04	15.65	9.00	20.20
05	18.65	12.00	23.20
06	21.65	15.00	26.20
07	24.65	18.00	29.20
08	27.65	21.00	32.20
09	30.65	24.00	35.20
10	33.65	27.00	38.20
11	36.65	30.00	41.20
12	39.65	33.00	44.20

PART NUMBER SCHEME:

10136655-XX X X LF

NO OF POS.
02: 2 POS.
5
12: 12 POS.

HSG MATERIAL, GLOW WIRE COMPATIBLE
1. COMPATIBLE
2. NON COMPATIBLE

PLATING
1. TIN
2. GOLD FLASH
3. 15u" Au, TIN ON TAILS
4. 30u" Au, TIN ON TAILS

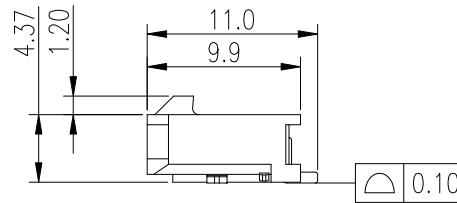
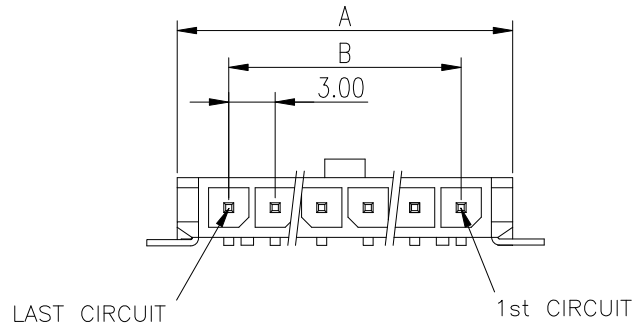

ALL SOLDER TAIL

mat'l. code		surface		tolerance		projection		product family	
		✓				⊕		MINITEK PWR3.0	
ltr		ecn no		dr		date		title	
A		TAI		2015-09-23		angles		MINITEK PWR3.0 R/A HEADER, SINGLE ROW, SMT TAILS AND HOLD DOWN	
						X.X ±0.3			
						X.XX ±0.2			
						X°±2°			
				dr		KENNY TAI		2015-08-21	
				enr		KENNY TAI		2015-08-21	
				chr		KENNY TAI		2015-08-28	
				appd		PM ZHENG		2015-09-23	
sheet index		revision sheet		A		A		type	
				1		2		CUSTOMER Drawing	

PRODUCT NUMBER
SEE PART NO. SCHEME

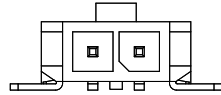

2 POS

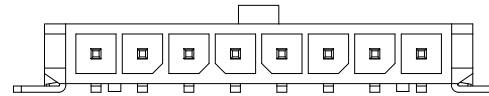

8 POS

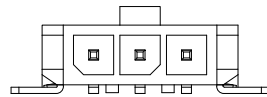
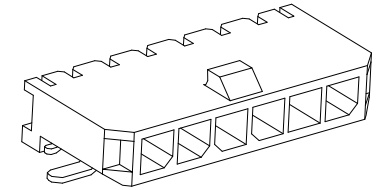

3 POS

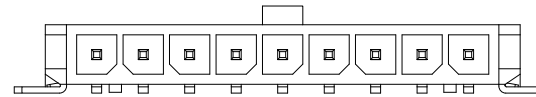

9 POS

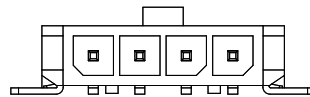

4 POS

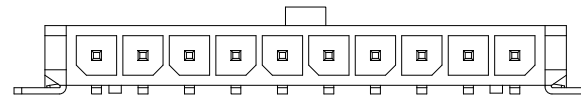

10 POS

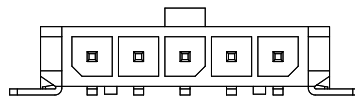

5 POS

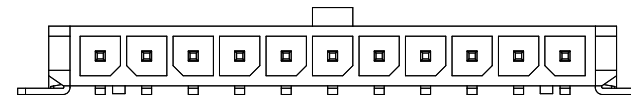

11 POS

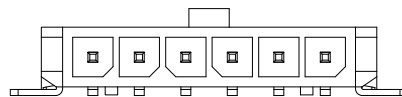

6 POS

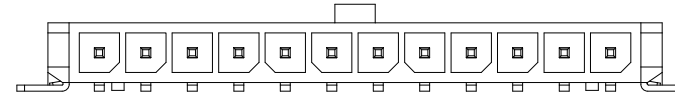

12 POS

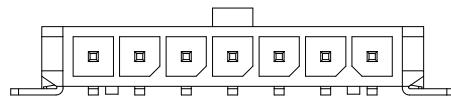

7 POS

mat'l. code		surface		tolerance		projection		product family	
		✓				⊕		MINITEK PWR3.0	
ltr		ecn no		dr		date		title	
								MINITEK PWR3.0 R/A HEADER, SINGLE ROW, SMT TAILS AND HOLD DOWN	
								scale	
								MM	
								sheet 2 of 2	
								size	
								A4	
								type	
								CUSTOMER Drawing	
sheet index		revision sheet		A 1		A 2			

