

**flare TIME FM15-1 24V**

flare TIME FM15-1 24V  
Multi-function Timer  
24 V AC/DC  
81.020.0020.0

- Multi-function timer
- Excellent visibility of color display
- 15 selectable time functions
- Front panel mounting (48 x 48 mm)
- Wide temperature range

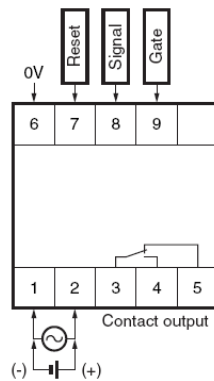

Connection / Block diagram

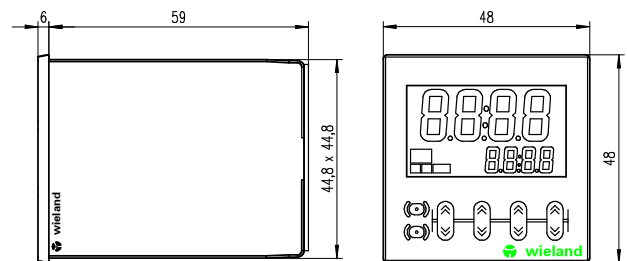

Dimensional diagram

## Technical Data

flare TIME FM15-1 24V		Best.-Nr. 81.020.0020.0
<b>Input / Control</b>		
Rated supply voltage	[U <sub>I,N</sub> ]	24 V AC / 12 - 24 V DC
Supply voltage range		20.4 ... 26.4 V AC / 10.8 ... 26.4 V DC
Line frequency AC		50/60 Hz
Rated power consumption	[P <sub>I,max</sub> ]	5.1 VA @ 24 V AC / 2.4 V @ 24 V DC
<b>Output / Switching Contact</b>		
Contacts		1 changeover contact
Max. load	(Ohmic load)	5 A, 250 V AC / 30 V DC AC15: 250 V / 3 A AC13: 250 V / 5 A DC13: 30 V / 0.5 A
Minimum load		10 mA at 5 V DC
Rated voltage		230 V AC
Contact material		AgNi
Life expectancy mechanical		10 x 10 <sup>6</sup> operations
Life expectancy electrical		100 x 10 <sup>3</sup> operations (5A at 250V, 1800 op./h)
<b>Time Ranges / Operating Modes</b>		
Time ranges (10 time ranges)		0.001 ... 9.999 s / 0.01 ... 99.99 s / 0.1 ... 999.9 s / 1 ... 9999 s / 1 s ... 99 min 59 s / 0.1 ... 999.9 min / 1 ... 9999 min / 1 min ... 99 h 59 min / 0.1 ... 999.9 h / 1 ... 9999 h
Accuracy of operating time and setting error		±0.01 % ±50 ms
Minimum input signal width		1 or 20 ms, selectable

## flare TIME FM15-1 24V

### Technical Data

flare TIME FM15-1 24V	Best.-Nr. 81.020.0020.0
Operating modes (15 functions)	A: Signal ON Delay I A1: Signal ON Delay II A2: Power ON Delay I A3: Power ON Delay II b: Repeat Cycle 1 b1: Repeat Cycle 2 d: Signal OFF Delay E: Interval F: Cumulative Timer Z: ON/OFF-duty-adjustable flicker S: Stopwatch ton: Flicker ON Start 1 ton-1: Flicker ON Start 2 toff: Flicker OFF Start 1 toff-1: Flicker OFF Start 2
Functional Display	(see Fig. 2 Control and display elements)
a - LED display	LED display, 4 digits; color selectable (red, green, orange)
b - Symbol display	Symbol display
c -	LED display, 4 digits (green)
Isolation Property	
Dielectric strength (input/output)	2.000 V AC (50/60 Hz, for 1 min)
Insulation resistance (A1, A2 / contacts)	min. 100 MΩ at 500 V DC
Approvals and Standards	
UL	cURus
CE	EMV 2004/108/EC; Low voltage 2006/95/EC
Safety Standard	EN61812-1
Product Standard	EN61812-1
EMV immunity	EN61000-4-2, /-4-3, /-4-4, /-4-5 /-4-6 / -4-11
EMV emission	EN55011
Operation / Dimensions / Wiring	
Operating temperature range [T <sub>U</sub> ]	-10 ... +55 °C
Storage temperature range [T <sub>UL</sub> ]	-20 ... +70 °C
Humidity in operation	25 ...85 % RH
Dimension (W x H x D)	48 x 48 x 65 mm
Installation dimension/ Mounting opening (B x H)	44.8 x 44.8 mm (depth 59 mm)
Weight	ca. 120 g
Housing material	Plastic
Mounting	front panel mounting, 48 x 48 mm
Cooling	Free convection
IP protection	IP66 with enclosed seal
Clamp type	Screw clamp
Connector cross section (min.) solid/stranded	0.32 mm <sup>2</sup> (AWG22)
Connector cross section (max.) solid/stranded	1.5 mm <sup>2</sup> (AWG18)
Strip length	8 mm max.
Torque	0.74 ... 0.90 Nm
Connections / Wiring	(see Fig. 1 Connections / Wiring)
1, 2	Supply voltage
3, 4, 5 (Relay 15, 16, 18)	Changeover contact (switching output)
6	Common for control inputs
7	Control input 'Reset'
8	Control input 'Signal'
9	Control input 'Gate'
Control elements	(see Fig. 2 Control and display elements)
d - 'MODE'	MODE key
e - 'RST'	Reset key
f, g - Pushbuttons	Parameter setting for digits 4, 3, 2, 1 (f = op / g = down)

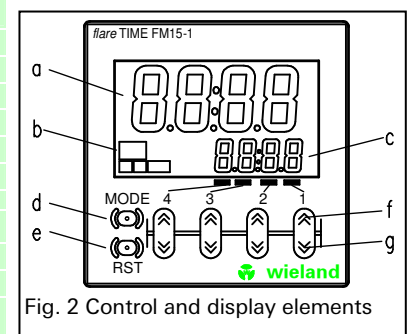
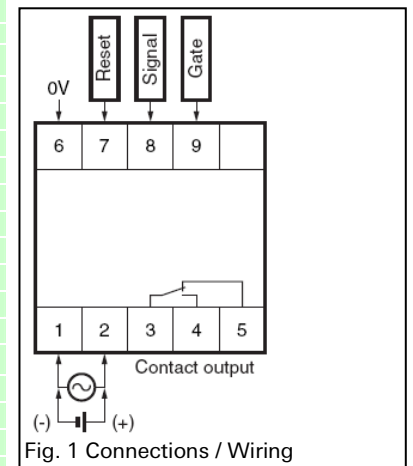

## flare TIME FM15-1 24V

### Time modes

#### Mode A: Signal ON delay 1 (Timer resets when power comes ON.)

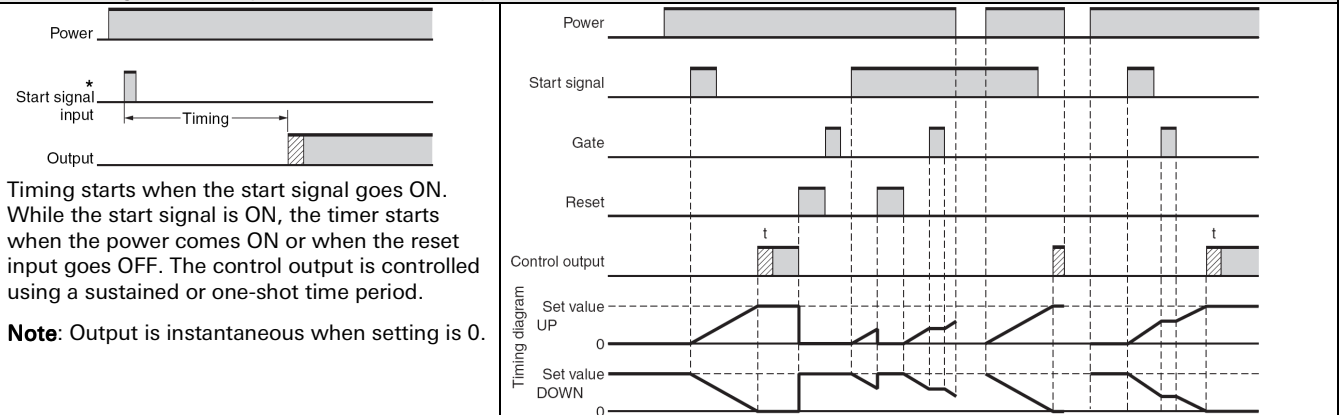

#### Mode A-1: Signal ON delay 2 (Timer resets when power comes ON.)

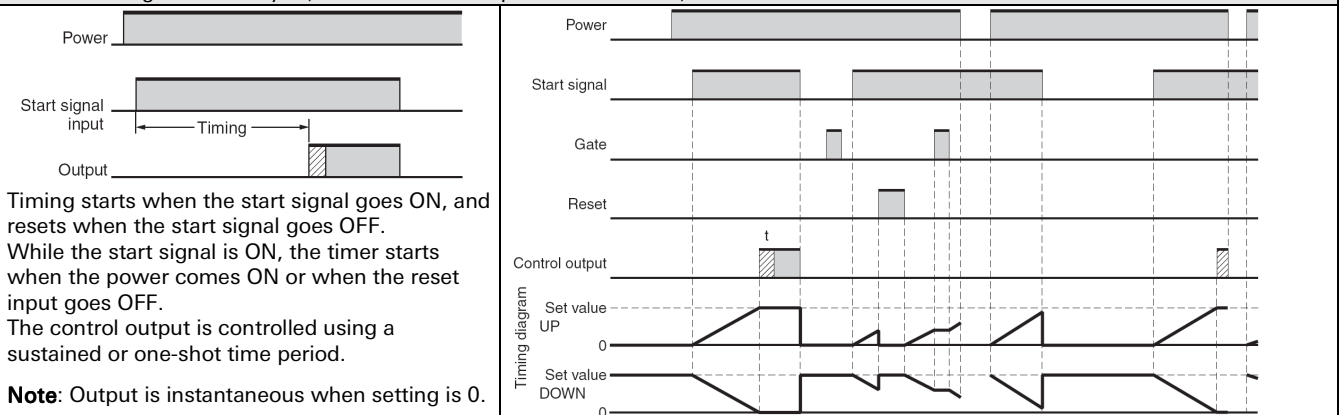

#### Mode A-2: Power ON delay 1 (Timer resets when power comes ON.)

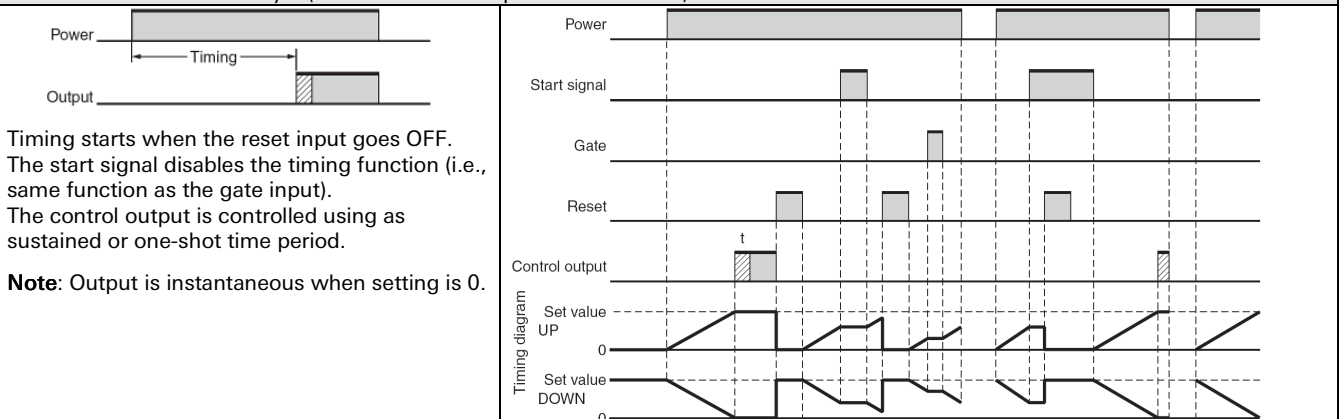

#### Mode A-3: Power ON delay 2 (Timer does not reset when power comes ON.)

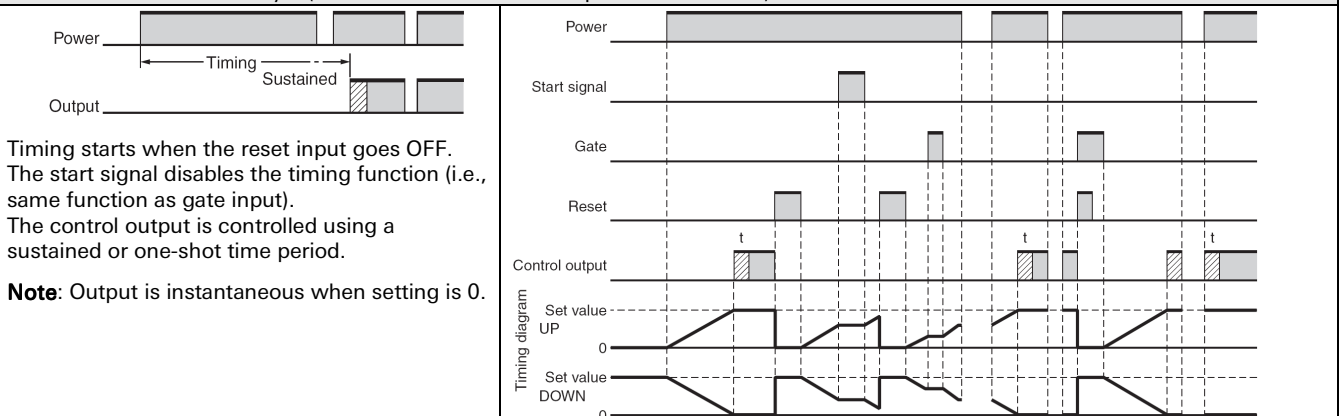

## flare TIME FM15-1 24V

(Time modes)

### Mode b: Repeat cycle 1 (Timer resets when power comes ON.)

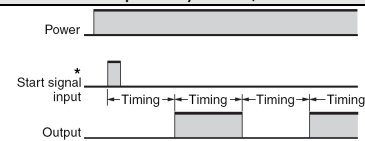

Timing starts when the start signal goes ON.  
The status of the control output is reversed when time is up (OFF at start).  
While the start signal is ON, the timer starts when the power comes ON or when the reset input goes OFF.

**Note:** Normal output operation will not be possible if the set time is too short.  
Set the value to at least 100 ms (contact output type).

#### Sustained Output

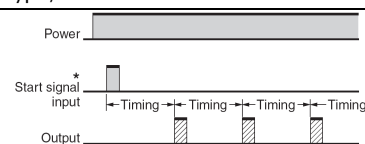
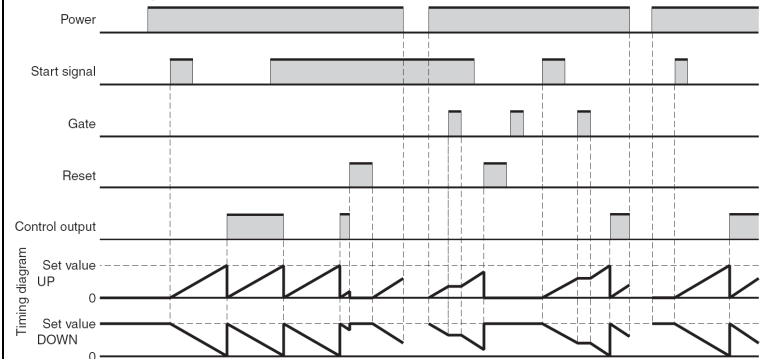

Timing starts when the start signal goes ON.  
The control output is turned ON when time is up.  
While the start signal is ON, the timer starts when the power comes ON or when the reset input goes OFF.

**Note:** Normal output operation will not be possible if the set time is too short.  
Set the value to at least 100 ms.

#### One-shot Output

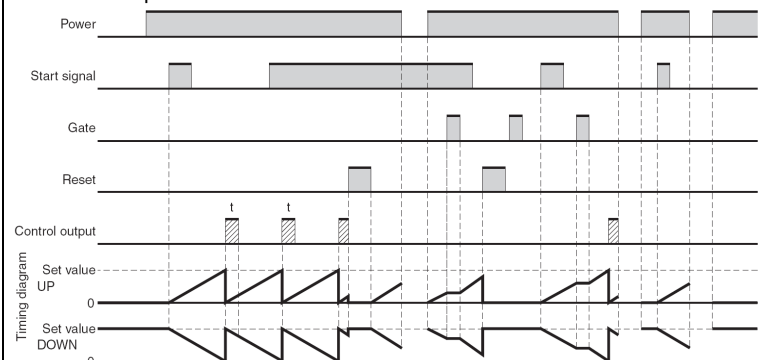

### Mode b-1: Repeat cycle 2 (Timer does not reset when power comes ON.)

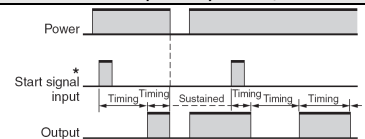

Timing starts when the start signal goes ON.  
The status of the control output is reversed when time is up (OFF at start).  
While the start signal is ON, the timer starts when the power comes ON or when the reset input goes OFF.

**Note:** Normal output operation will not be possible if the set time is too short.  
Set the value to at least 100 ms.

#### Sustained Output

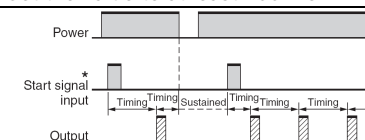
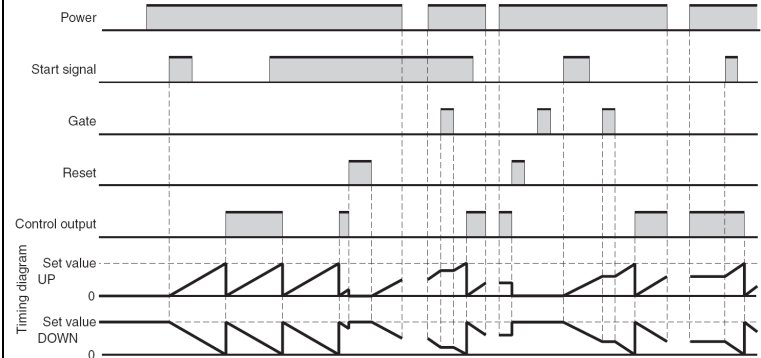

Timing starts when the start signal goes ON.  
The control output is turned ON when time is up.  
While the start signal is ON, the timer starts when the power comes ON or when the reset input goes OFF.

**Note:** Normal output operation will not be possible if the set time is too short.  
Set the value to at least 100 ms.

#### One-shot Output

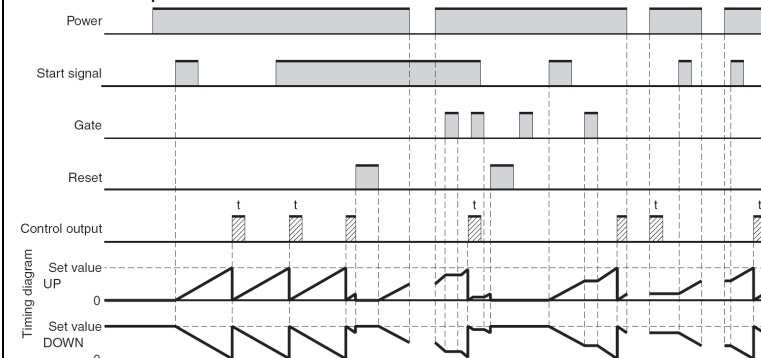

## flare TIME FM15-1 24V

(Time modes)

### Mode d: Signal OFF delay (Timer resets when power comes ON.)

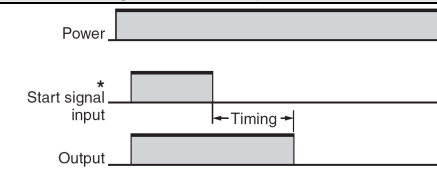

\* Start signal input is enabled during timing.

The control output is ON when the start signal is ON (except when the power is OFF or the reset is ON).

The timer resets when the time is up.

**Note:** Output functions only during start signal input when setting is 0.

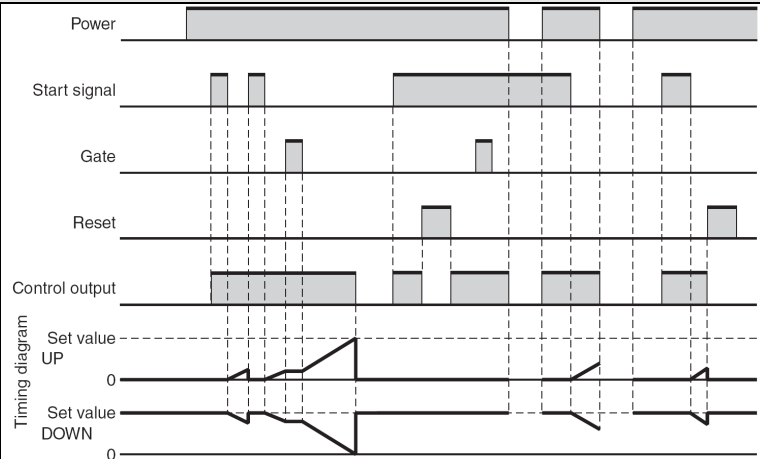

### Mode E: Interval (Timer resets when power comes ON.)

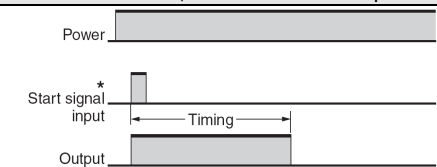

\* Start signal input is enabled during timing.

Timing starts when the start signal comes ON.

The timer resets when the time is up.

While the start signal is ON, the timer starts when the power comes ON or when the reset input goes OFF.

**Note:** Output is disabled when the setting is 0.

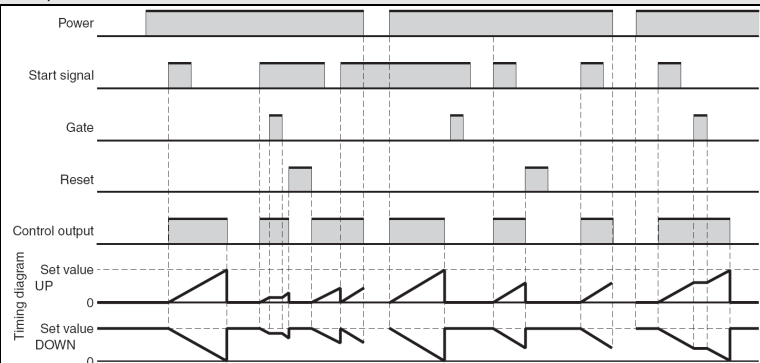

### Mode F: Cumulative (Timer does not reset when power comes ON.)

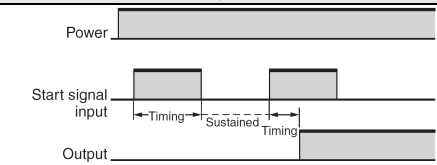

Start signal enables timing (timing is stopped when the start signal is OFF or when the power is OFF).

A sustained control output is used.

**Note:** Output is disabled when the setting is 0.

When the FM15-1 is used with power start in mode F mode or F-1 (i.e., cumulative operation with output on hold), there will be a timer error (approximately 100 ms each time the FM15-1 is turned ON) due to the characteristics of the internal circuitry. Use the FM15-1 with signal start if timer accuracy is required.

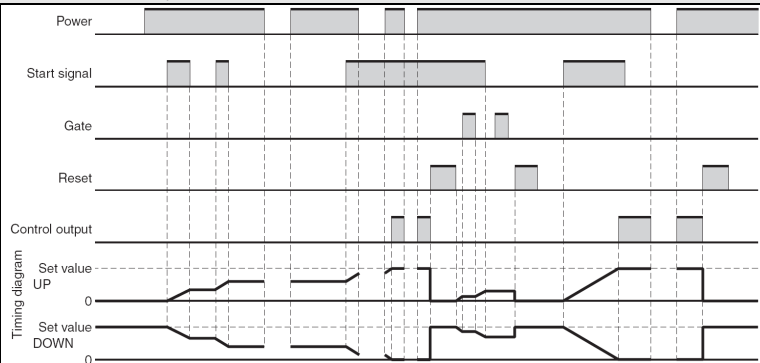

### Mode Z: ON/OFF-duty-adjustable flicker (Timer resets when power comes ON.)

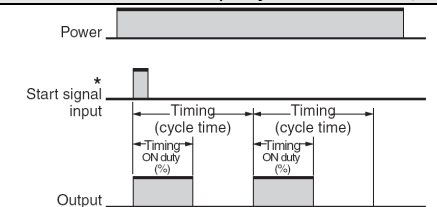

\* Start signal input is disabled during timing.

Timing starts when the start signal goes ON.

The status of the control output is reversed when time is up (ON at start).

While the start signal is ON, the timer starts when the power comes ON or when the reset input goes OFF.

**Note:** Normal output operation will not be possible if the set time is too short.

Set the value to at least 100 ms.

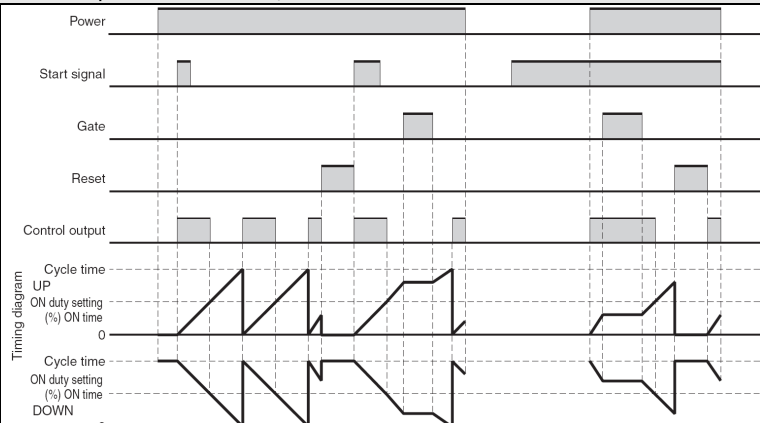

## flare TIME FM15-1 24V

(Time modes)

### Mode S: Stopwatch (Timer resets when power comes ON.)

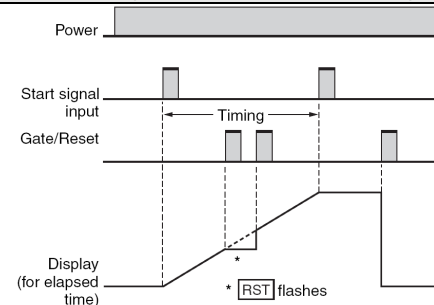

The signal starts and stops timing.  
The display is held and timing is continued if the reset or gate input is received during timing operation.  
The timer resets if the reset or gate input is received when the timing operation is stopped.

**Note:** Output is instantaneous when setting is 0.

Instantaneous Contact Outputs

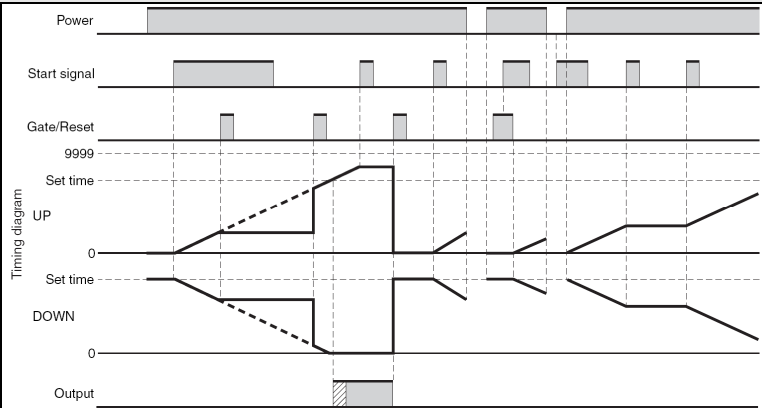

### Mode A-2: Power ON delay (Timer resets when power comes ON.)

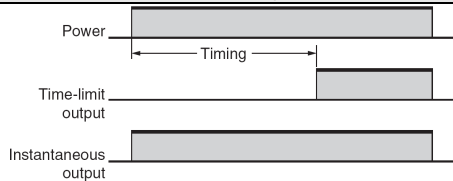

The Timer starts when the power comes ON or when the reset input goes OFF.

**Note:** Output is instantaneous when setting is 0.

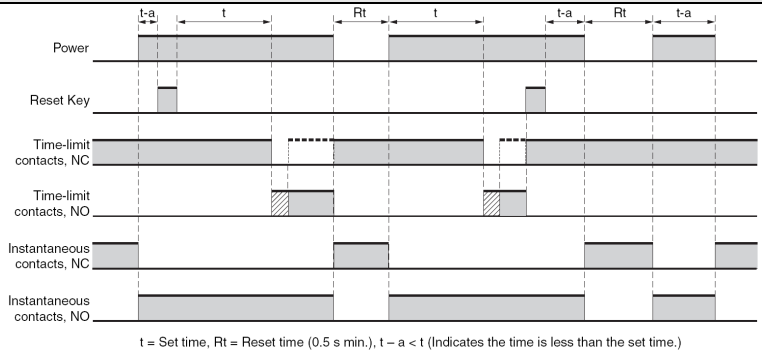

### Mode b: Repeat cycle 1 (Timer resets when power comes ON.)

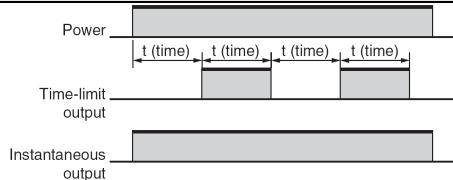

The Timer starts when the power comes ON or when the reset input goes OFF.

**Note:** Normal output operation will not be possible if the set time is too short.  
Set the value to at least 100 ms.

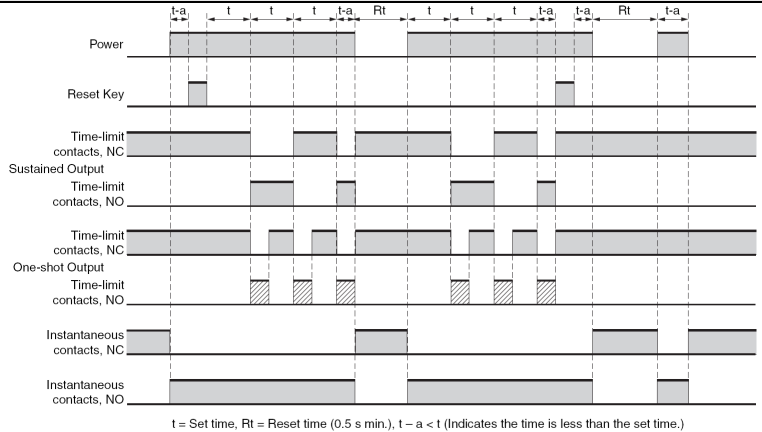

### Mode E: Interval (Timer resets when power comes ON.)

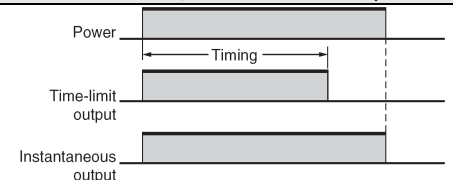

The Timer starts when the power comes ON or when the reset input goes OFF.

**Note:** Output is not instantaneous when setting is 0.

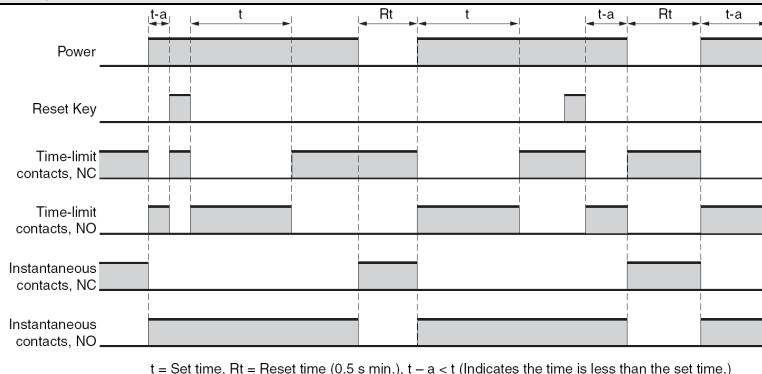

## flare TIME FM15-1 24V

(Time modes)

**Mode Z:** ON/OFF-duty adjustable flicker (Timer resets when power comes ON.)

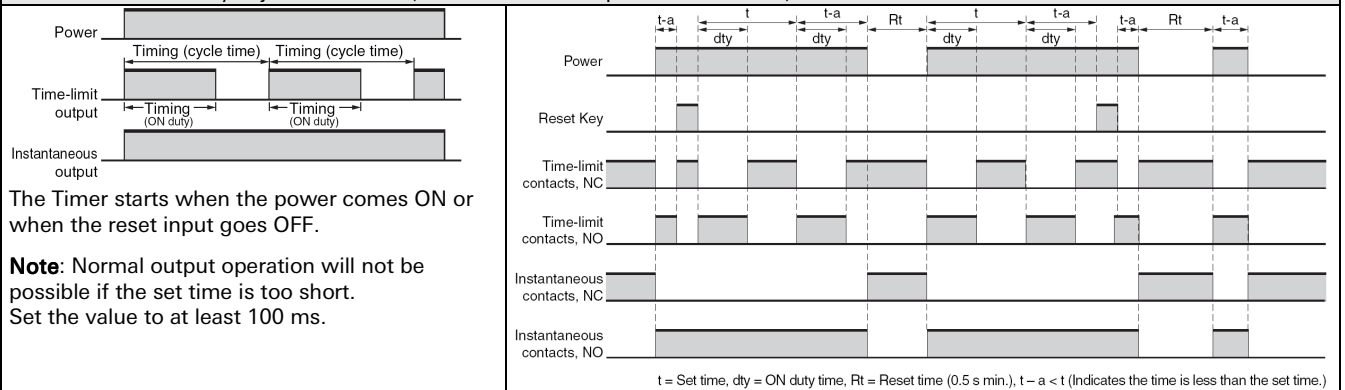

The Timer starts when the power comes ON or when the reset input goes OFF.

**Note:** Normal output operation will not be possible if the set time is too short. Set the value to at least 100 ms.

### DIP Switch Settings

see Fig. 3 DIP switch settings, Tab. 1 DIP switch settings, Tab. 2 Time range settings, Tab. 3 Output mode settings

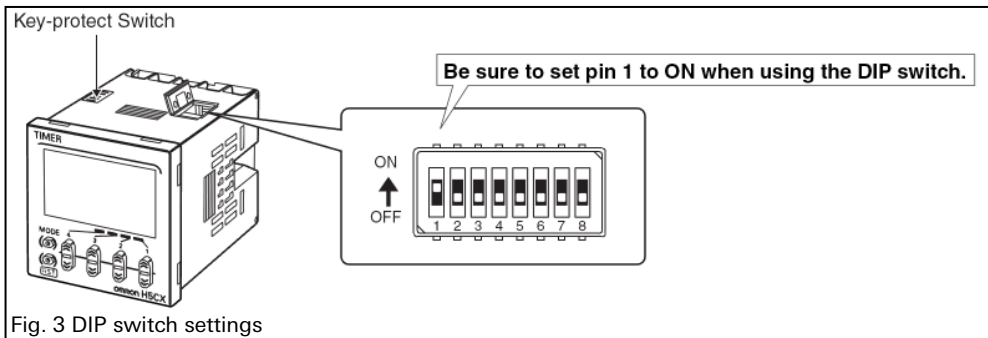

Fig. 3 DIP switch settings

SW	Item	off	ON
1	DIP switch	disabled	enabled
2	Time range	see Tab. 2 Time range settings	
3			
4	Output mode	see Tab. 3 Output mode settings	
5			
6	Timer mode	UP	DOWN
7			
8	Input signal width	20 ms	1 ms

Tab. 1 DIP switch settings

SW2	SW3	SW4	Time range
ON	ON	ON	0,001 ... 9,999 s
off	off	off	0,01 ... 99,99 s
ON	off	off	0,1 ... 999,9 s
off	ON	off	1 ... 9999 s
ON	ON	off	0 min 01 s ... 99 min 59 s
off	off	ON	0,1 ... 999,9 min
ON	off	ON	0 h 01 min ... 99 h 59 min
off	ON	ON	0,1 ... 999,9 h

Tab. 2 Time range settings

SW5	SW6	Output mode
off	off	Mode A: Signal ON Delay 1(Timer resets when power cones ON)
ON	off	Mode A-2: Signal ON Delay 2(Timer resets when power cones ON)
off	ON	Mode E: Interval (Timer resets when power cones ON)
ON	ON	Mode F: Cumulative (Timer does not reset when power cones ON)

Tab. 3 Output mode settings

### Key Protect

see Fig. 4 Key protect, Tab. 4 Key protect settings

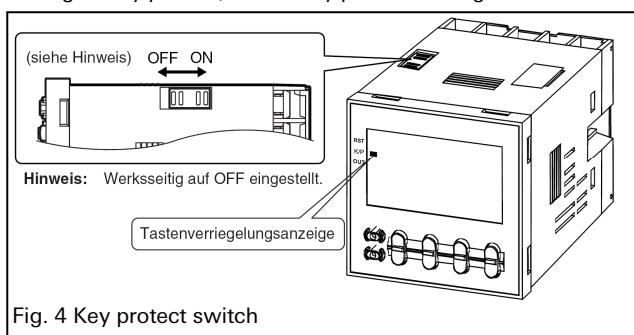

Fig. 4 Key protect switch

KP level (Key Protect)	Changing mode	Switching display during operation	Reset key	Up/down key
KP-1 (default setting)	no	valid	valid	valid
KP-2	no	valid	no	valid
KP-3	no	valid	valid	no
KP-4	no	valid	no	no
KP-5	no	no	no	no
KP-6	no	no	valid	valid
KP-7	no	no	no	valid

Tab. 4 Key protect settings