

flare TIME M4-2

flare TIME M4-2
 Multifunctional Time Relay
 24-240 V AC/DC
 81.020.0001.0

- Multifunctional Time Relay
- 4 selectable operating modes
- Multi range time settings
- 8 time ranges
- Synchronous / Time controlled mode selectable (for output 2)
- Multiple voltage supply 20.4 ... 264 V AC/DC
- Mounting width 22.5 mm

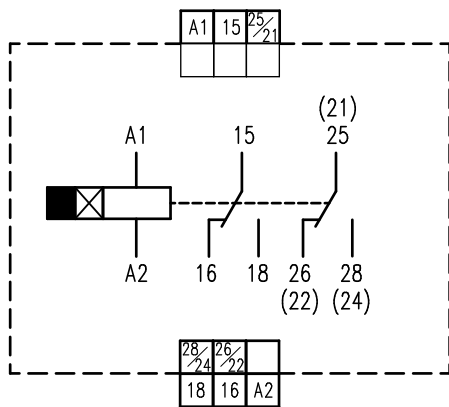

Block diagram

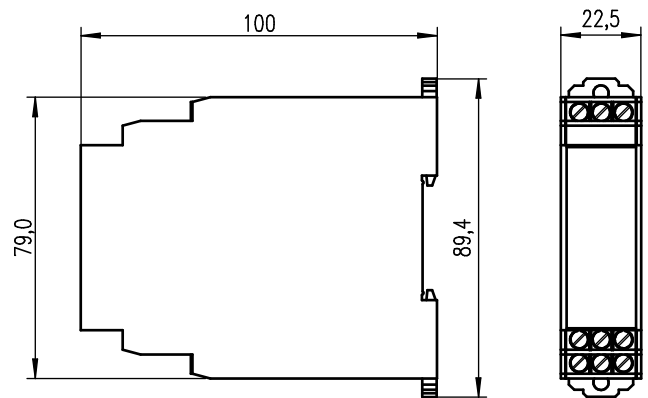

Dimensional diagram

Technical Data

flare TIME M4-2		Order no. 81.020.0001.0
Input / Control		
Raged supply voltage A1-A2	[U _{I N}]	24 ... 240 V AC/DC
Voltage range		20.4 ... 265 V AC/DC
Line frequency AC		50/60 Hz
Rated power consumption	[P _{I max}]	6.6 VA @ 240 V AC, 1.2 W @ 24 V DC
Output / Switching Contact		
Contacts		2 changeover contacts
Contact load max.		5 A at 250 V AC / 5 A at 24 V DC, ohmic load
Contact output minimum load		10 mA at 5 V DC
Switching voltage max.		250 V AC / 30 V DC
Rated breaking capacity		see Fig. 1 Load limiting curve (d = distance to adjacent modules)
Contact material		AgNi
Life cycle		100 x 10 ³ operations (5 A at 250 V AC, ohmic load, 360 operations/h)
Time Ranges / Operating Modes		
Time ranges		0.1 s / 1 s / 10 s / 1 m / 10 m / 1 h / 10 h / 100 h
Accuracy of operating time		max. ±1 % of full scale
Setting error		max. ±10 % of full scale ±0.05 s
Minimum input signal width		50 ms (start input)
Influence of voltage		max. ±0.5 % of full scale
Influence of temperature		max. ±2 % of full scale

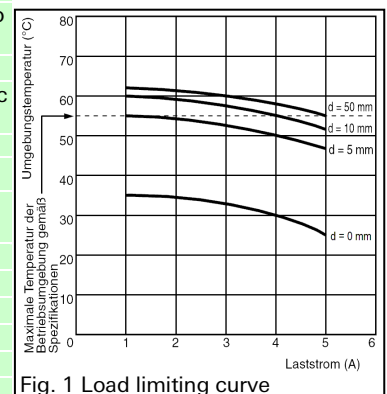

Fig. 1 Load limiting curve

flare TIME M4-2

Technical Data

flare TIME M4-2		Order no. 81.020.0001.0
Operating modes (Fig. 2 - e) (4 time functions)	A: ON Delay B2: Flicker ON start E: Single shot J: ON delayed single shot, fixed time	
Operating modes for output 2 (Fig. 2 - f) (2 modes)	INST: synchronous to supply voltage TIME: time controlled output	
Change of operating mode (Fig. 2 - e)	Without power supply, else error	
Functional Display		
(see Fig. 2 Control and display elements)		
LED relay control (Fig. 2 - d) Operating voltage off Operating voltage on time running time expired	LED off / n. o. contact open LED slow flashing / n. o. contact open LED fast flashing / n. o. contact open LED on / n. o. contact closed	
LED relay contact (Fig. 2 - c) Contact open Contact closed	LED off LED on	
Isolation Property		
Dielectric strength (input/output)	2.000 V AC (50/60 Hz, for 1 min)	
Insulation resistance (A1, A2 / contacts)	min 100 MΩ at 500 V DC	
Approvals and Standards		
UL	cURus	
CE	EMV 2004/108/EC; Low voltage 2006/95/EC	
Safety Standard	EN61812-1	
Product Standard	EN61812-1	
EMV immunity	EN61000-4-2, /-4-3, /-4-4, /-4-5	
EMV emission	EN61000-3-2, /-3-3, EN55011 Class B	
Operation / Dimensions / Wiring		
Operating temperature range	[T _U]	-20 ... +55 °C
Storage temperature range	[T _U]	-40 ... +70 °C
Humidity in operation		25 ... 85 % RH
Dimensions (W x H x D)		22.5 x 100 x 79.0 mm
Weight		ca. 120 g
Housing material		Plastic
Mounting on		35 mm rail acc. EN 60715
Cooling		Free convection
IP protection		IP20
Clamp type		Screw clamp
Connector cross section (min.)	solid/stranded	0.2 mm ² (AWG24)
Connector cross section (max.)	solid/stranded	2.5 mm ² (AWG14)
Strip length		8 mm max.
Recommended torque		0.49 Nm
Terminal Connections		
A1, A2		Supply voltage
15, 16, 18		Changeover contact (relay 1)
25 (21), 26 (22), 28 (24)		Changeover contact (relay 2)
Control Elements		
(see Fig. 2 Control and display elements)		
a - turn switch		Time range (0.1 s ... 100 h)
b - turn potentiometer		Time duration (0 ... 12 x time range)
e - turn switch		Operating mode / time function
f - turn switch		Operating mode for output 2

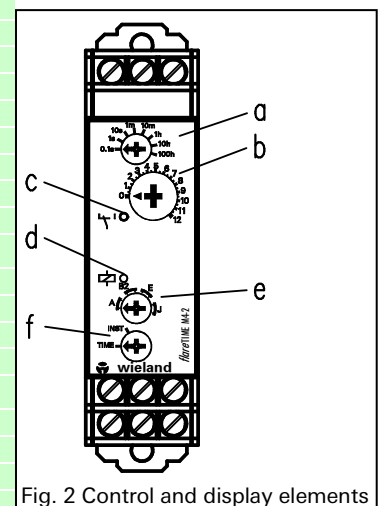

Fig. 2 Control and display elements