



ETA-USA

The Power Professionals

AOJS25

25W AC/DC



AOJS-25



Features

- Inrush Current Limit
- Wide Input voltage range
[Universal input voltage or user selectable voltage]
- Over voltage protection
- Overcurrent protection
- 3 Yr warranty**

MODEL/CHANNEL		Unit	AOJS25-3.3	AOJS25-5	AOJS25-9	AOJS25-12	AOJS25-15	AOJS25-24	AOJS25-48	
OUTPUT	Nominal Voltage	[V]	3.3	5.0	9.0	12.0	15.0	24	48	
	Setting Voltage Range	[V]	3.26 ~ 3.33	4.95 ~ 5.05	8.91 ~ 9.09	11.88 ~ 12.12	14.85 ~ 15.15	23.76 ~ 24.24	-	
	Current	[A]	48	48	26.7	20	16	1.1	0.57	
	Line Regulations	[mV]	17	25	45	60	75	120	240	
	Load Regulations	[mV]	66	75	50	60	75	120	240	
	Temperature Drift	[mV]	50	75	135	180	225	360	720	
	Ripple & Noise(pk-pk) (*1)	[mV]	80	80	120	120	120	120	220	
	Ripple	[mV]	50	50	100	100	100	100	180	
	Turn-on Time typ.	[ms]	1500 max (AC IN 100V, Io=100%)					1500 110VAC in		
Hold-up Time typ.	[ms]	14 (AC IN 100V, Io 100%)					20 110VAC in			
INPUT	Voltage, Frequency	[V]	AC100 ~240V (AC88 ~264VAC) , 50/60Hz(47 – 440) or DC240-370V (User selectable)							
	Current Typ. 110V 220V	[A]	0.45 0.3						0.7 0.4	
	Efficiency Typ. 110V 220V	[%]	74	79	81	82	82	84	85	
	Inrush Current Typ. 110V 220V	[A]	15A (AC IN 110V, LO=100%, 30°C TYP (AC IN 220V, LO-100%, Cold Start)							
	Leakage Current 110V 1mA Max 220V	[mA]	- 1.0							
Function	Over Voltage Protection	[V]								
	Over Current Protection(*2)	[A]	Short Protection							
	Remote Sensing	-	Available							
	Remote ON.OFF	-	Available							
	Cooling/O.T.P	-	Convection cooling							
Electrical Isolation	(1) Input - Output	-	AC 3.0 KV 1min., cut-off: 20mA / DC 500V 100 MO							
	(2) Input - F.G	-	AC 1.5 KV 1min., cut-off: 20mA / DC 500V 100 MO							
	(3) Output - F.G	-	AC 0.5 KV 1min., cut-off: 100mA / DC 500V 100 MO							
Environment	Operating temp. & Humidity	-	-25 ~+70 C with derating. 20~90% RH (NON condensing)							
	Storage temp. & Humidity	-	-20 ~75 C. 20~90% RH (NON condensing)							
	Vibration	-	10~55Hz @ 1 G 3minutes PERIOD, 30minutes along X,Y & Z axis							
Dimension	Size(WxDxH) / Weight	mm/g	79X 51X 28.5/ 200							
Safety	CB, CE, UL, C-UL	-	Approved							
Emission	Conducted Emission	-	Complies with EN55022-B, FCC-B, EN55011							



1. BLOCK DIAGRAM

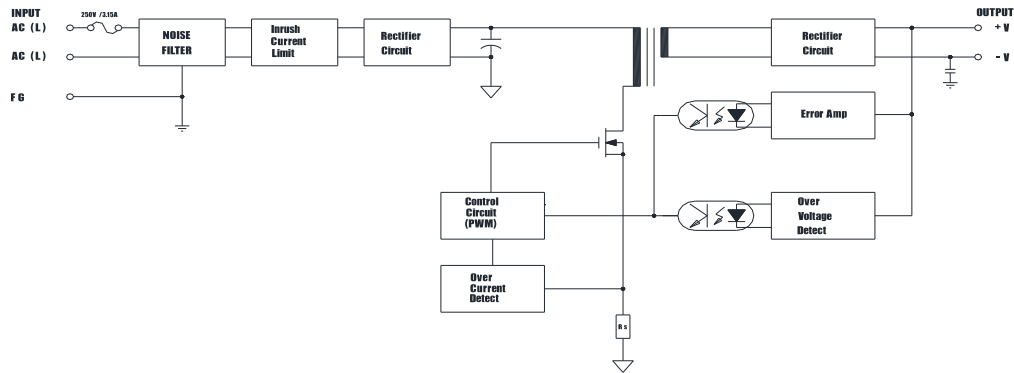

2. Terminal Connection

Mark	Pin Connection	Function
L	AC Live line	SMPS AC input Terminal (Fuse in Line)
N	AC Neutral line	SMPS AC input Terminal
F.G	Frame ground	SMPS AC Grounding, CASE Grounding
+V	DC Output (+)	DC (+) output Terminal
-V	DC Output (-)	DC (-) output Terminal

3. Function

3-1. Adjustable output voltage range

o Output voltage can be adjustable within $\pm 5\%$ but it could cause malfunction if it is out of Adjustable range

3-2. O.C.P : Over Current Protection

o Over current protection circuit is to be in operation to cut off the output in order to protect SMPS if output current exceeds over 110% of rated output current due to malfunction of application system or short-circuit of external connection.

3-3. O.V.P : Over Voltage Protection)

o Over voltage protection circuit is to be in operation to cut off the output in order to protect SMPS if output voltage exceeds over 115% of rated output voltage or reversal voltage occurs.

o Over voltage protection feature is to be off, once the system is restored after the problem for malfunction is resolved, followed by cutting off AC input power for 3 minutes. If output voltage is NOT restored to normal, however, it is highly recommended to consult with personnel at customer support to monitor possible internal damage to the product.





4. Series operation / Parallel operation

4-1. Both connection systems as shown at A (Fig 1.) or B (Fig 2.) can be used during series operation. User's guide

4. Series operation / Parallel operation

4-2. In parallel operation A at Figure 4, current capacity cannot be increased, while it should be used for backup only. Moreover, diode that is to be added during parallel operation should be selected after considering its voltage drop (V_f), output voltage (V_o) and current capacity (I_o).

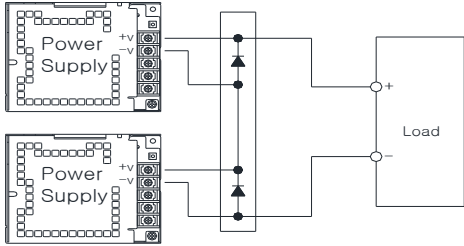

Fig 1.

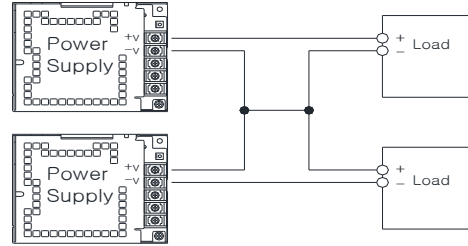

Fig 2.

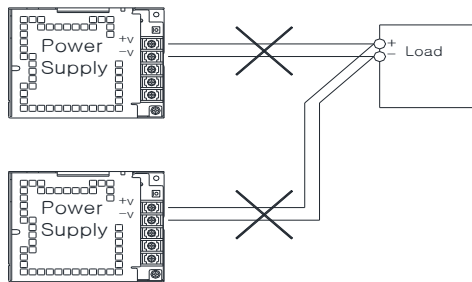

Fig 3.

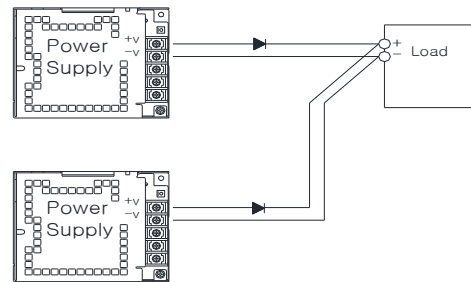

Fig 4.

5. Mounting method

5-1. It should be mounted as follow in the consideration of air cooling

- o Mounting method should be considered with airflow..
- o Leave enough spaces between units when several units mounted together
- o Forced air cooling makes protection against heat better



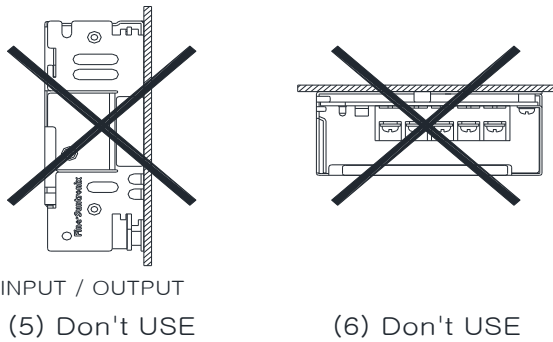
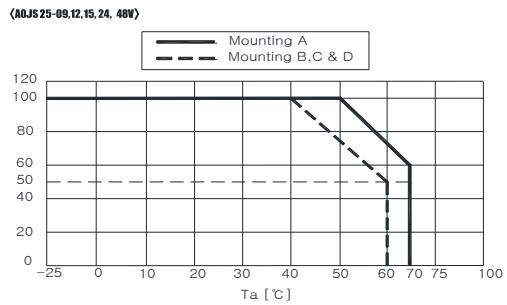
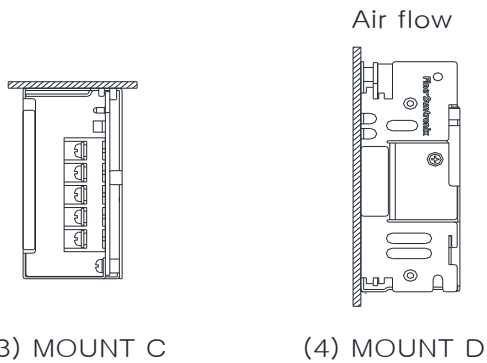
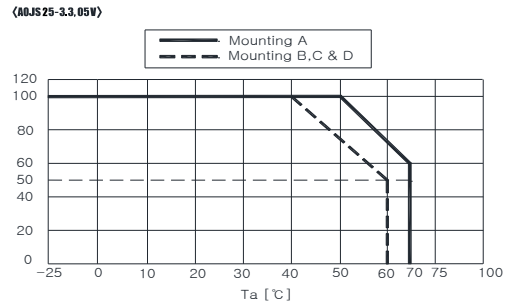
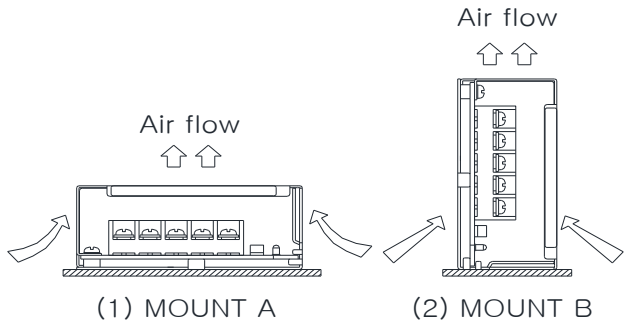

Fig 1.





5-1. It should be mounted as follow in the consideration of air cooling
User's guide

- o Mounting method should be considered with airflow.
- o Leave enough spaces between units when several units mounted together
- o Forced air cooling makes protection against heat better

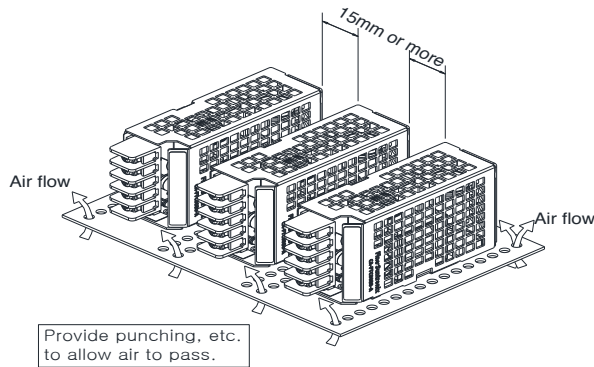
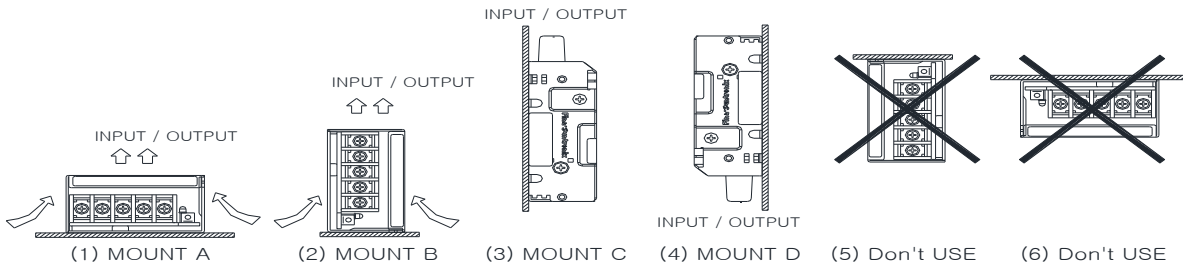

6. Output derating curve

6-1. Output derating curve should be considered based on existence of top case and installation method.

6-2. Output derating curve

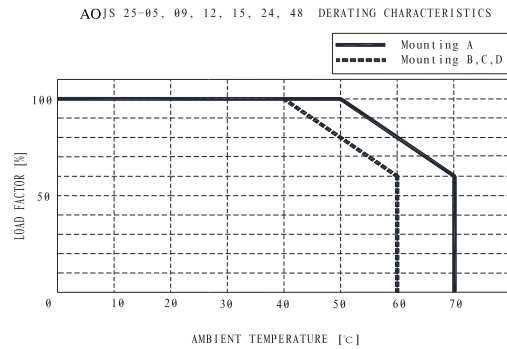
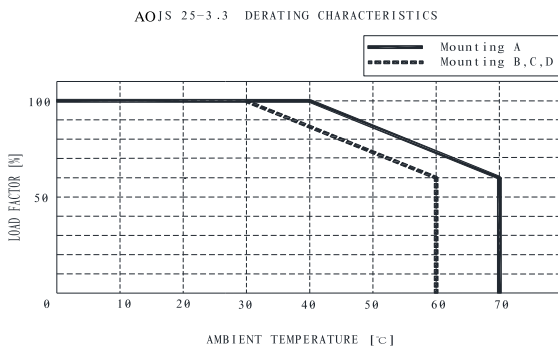



ETA-USA

The Power Professionals

7. Caution

- o Please confirm if the capacity of the product is suitable for your intended use before putting it in use.
- o Only the rated input voltage specified on the product should be used.
- o Only the wires with rated capacity should be connected to this product, as allowable voltage and current is varied according to each type of wire.
- o Ground terminal of this product must be grounded before use to prevent electric shock or electromagnetic interference.
- o Be cautious to keep the product clean as foreign subject near input & output terminal or inside of the product could cause serious damages.
- o For the purpose of safety as well as reliability of the product, please avoid using the product at the following sites:
 - A place near water or fire
 - A place with high room temperature and poor ventilation
 - A place with a presence of foreign subject or dust
 - A place near volatile or flammable compounds
 - A place with high humidity
 - A place vulnerable for vibration or shock



ETA-USA

16170 Vineyard Blvd. Suite 180 Morgan Hill, CA 95037 <http://www.eta-usa.com>
Toll-free (US only): 800-ETA-POWR (800-382-7697) Telephone: 408 778-2793 FAX: 408-779-2753