

Description

Electronic circuit protector type ESX10-T is designed to ensure **selective** disconnection of DC 24 V load systems.

DC 24 V power supplies, which are widely used in industry today, will shut down the output in the event of an overload with the result that one faulty load in the system can lead to complete disconnection of all loads. As well as an unidentified failure this also means stoppage of the whole system.

Through **selective** disconnection the ESX10-T responds much faster to overload or short circuit conditions than the switch-mode power supply. This is achieved by active current limitation. The ESX10-T limits the highest possible current to 1.3 to 1.8 times the selected rated current of the circuit protector. Thus it is possible to switch on **capacitive loads of up to 75,000 μ F**, but they are disconnected only in the event of an overload or short circuit.

For optimal alignment with the characteristics of the application the current rating of the ESX10-T can be selected in fixed values from 0.5 A...12 A or in adjustable ratings e.g. [2 A/4 A/6 A]. Failure and status indication are provided by a multicolour LED and an integral short-circuit-proof status output or a potential-free signal contact. Remote operation is possible by means of a remote reset signal or a remote ON/OFF control signal. The manual ON/OFF button allows separate actuation of individual load circuits.

The ESX10-T, with a width of only 12.5 mm, can be snapped onto symmetrical rails ensuring ease of installation and saving space in control cabinets.

Upon detection of overload or short circuit in the load circuit, the MOSFET of the load output will be blocked to interrupt the current flow. The load circuit can be re-activated via the remote electronic reset input, control input or manually by means of the ON/OFF button.

Features

- Selective load protection, electronic trip characteristics.
- Suitable for all kinds of loads (DC 24 V motors upon request)
- Active current limitation for safe connection of capacitive loads up to 75,000 μ F and on overload/short circuit.
- **ESX10-TA/-TB:**
Current ratings 0.5 A...12 A
- **ESX10-TD:**
adjustable ratings [0.5 A/1 A/2 A], [2 A/3 A/4 A], [2 A/4 A/6 A] and [6 A/8 A/10 A]
- Reliable overload disconnection with $1.1 \times I_N$ plus, even with long load lines or small cable cross sections (see table 3).
- Manual ON/OFF button (S1).
- Control input IN+ for remote ON/OFF signal (option).
- Electronic reset input RE (option).
- Clear status and failure indication through LED, status output SF or Si contact F.
- Integral fail-safe element adjusted to current rating.
- Width per unit only 12.5 mm.
- Rail mounting
- Ease of wiring through busbar LINE+ and 0 V as well as signal bars and bridges.
- Additional versions with ATEX approval available.
Marking: $\text{II 3G Ex nA IIB T4 Gc X}$
ESX10-TA-...-E and ESX10-TB-...E

Please observe separate operating instructions:



ESX10-TD

Technical data ($T_{\text{ambient}} = 25^\circ\text{C}$, operating voltage $U_S = \text{DC } 24 \text{ V}$)

Operating data

Operating voltage U_S	DC 24 V (18...32 V)
Current rating I_N	fixed current ratings: Type ESX10-TA-... and -TB-...: 0.5, 1 A, 2 A, 3 A, 4 A, 6 A, 8 A, 10 A, 12 A adjustable ratings: Type ESX10-TD-...: [0.5 A/1 A/2 A], [2 A/4 A/6 A], [6 A/8 A/10 A] Type ESX10-TD-101-...: [2 A/3 A/4 A]
Closed current I_0	ON condition: typically 20...30 mA depending on signal output
Status indication by means of	<ul style="list-style-type: none"> • Multicolour LED: <ul style="list-style-type: none"> Green: <ul style="list-style-type: none"> - unit is ON, power-MOSFET is switched on - status output SF ON, supplies + DC 24 V Orange: <ul style="list-style-type: none"> - in the event of overload or short circuit until electronic disconnection Red: <ul style="list-style-type: none"> - unit electronically disconnected - load circuit/Power-MOSFET OFF OFF: <ul style="list-style-type: none"> - manually switched off (S1 = OFF) or device is dead - undervoltage ($U_S < 8 \text{ V}$) - after switch-on till the end of the delay period • status output SF (option) • potential-free signal contact F (option) • ON/OFF/ condition of switch S1

Load circuit

Load output	Power-MOSFET switching output (high side switch)
Overload disconnection	typically $1.1 \times I_N$ ($1.05...1.35 \times I_N$)
Short-circuit current I_K	Active current limitation with $I_{\text{Limit}} =$ typically $1.8/1.5/1.4/4.3 \times I_N$, I_{Limit} depending on I_N (typical I_{Limit} - values see table 1)
Trip characteristic	active current limitation (see table 1)
Trip thresholds/trip times (t_1, t_2) at overcurrent (I_{Limit} see table 1)	<ol style="list-style-type: none"> 1. threshold: at $I_{\text{load}} >$ typically $1.1 \times I_N...I_{\text{Limit}}$: $t_1 =$ typically 3s. 2. threshold: at $I_{\text{load}} = I_{\text{Limit}}$: $t_2 =$ typically 100 ms...3 s.
Temperature disconnection	internal temperature monitoring with electronic disconnection
Low voltage monitoring load output	with hysteresis, no reset required load "OFF" at $U_S < 8 \text{ V}$

Technical data ($T_{\text{ambient}} = 25^{\circ}\text{C}$, operating voltage $U_S = \text{DC } 24 \text{ V}$)

Starting delay t_{start}	typically 0.5 sec after every switch-on and after applying U_S
Disconnection of load circuit	electronic disconnection
Free-wheeling circuit	external free-wheeling diode recommended with inductive load
Several load outputs must not be connected in parallel	
Status output SF	ESX10-T.-114/-124/
Electrical data	plus-switching signal output, connects U_S to terminal 12 of module 17plus nominal data: DC 24 V / max. 0.2 A (short circuit proof) status output is internally connected to GND with a 10 kOhm resistor
Status OUT	ESX10-TB-114/-124 (signal status OUT), at $U_S = +24 \text{ V}$ $+24 \text{ V} = \text{S1 is ON}$, load output connected through $0 \text{ V} = \text{S1 is ON}$, load output blocked and/or switch S1 is OFF red LED lighted
OFF condition	0 V level at status output when: <ul style="list-style-type: none"> switch S1 is in ON position, but device is still in switch-on delay switch S1 is OFF, or control signal OFF, device is switched off no operating voltage U_S
Signal output F	ESX10-T.-101/-102
Electrical data	potential-free signal contact max. DC 30 V/0.5 A, min. 10 V/10 mA
ON condition LED green	voltage U_S applied, switch S1 is in ON position no overload, no short circuit
OFF condition LED off	<ul style="list-style-type: none"> device switched off (switch S1 is in OFF position) no voltage U_S applied
Fault condition LED orange	overload condition $> 1.1 \times I_N$ up to electronic disconnection
Fault condition LED red	electronic disconnection upon overload or short circuit
ESX10-TB-101	single signal, make contact contact SC/SO-SI open
ESX10-TB-102	single signal, break contact contact SC/SO-SI closed
Fault	signal output fault conditions: <ul style="list-style-type: none"> no operating voltage U_S ON/OFF switch S1 is in OFF position red LED lighted (electronic disconnection)
Reset input RE	ESX10-T.-124/-127
Electrical data	voltage: max. + DC 32 V high $> \text{DC } 8 \text{ V} \leq \text{DC } 32 \text{ V}$ low $\leq \text{DC } 3 \text{ V} > 0 \text{ V}$ power consumption typically 2.6 mA (+DC 24 V) min. pulse duration typically 10 ms
Reset signal RE (terminal 22)	The electronically blocked ESX10-TB-124/-127 may remotely be reset via an external momentary switch due to the falling edge of a +24 V pulse. A common reset signal can be applied to several devices simultaneously. Switched on devices remain unaffected.
Control input IN+	ESX10-T.-114
Electrical data	see reset input RE
Control signal IN+ (terminal 21)	+24V level (HIGH): device will be switched on by a remote ON/OFF signal 0 V level (LOW): device will be switched off by a remote ON/OFF signal
Switch S1 ON/OFF	unit can only be switched on with S1 if a HIGH level is applied to IN+

Technical data ($T_{\text{ambient}} = 25^{\circ}\text{C}$, operating voltage $U_S = \text{DC } 24 \text{ V}$)

LED display	ON: LED green OFF: LED red
General data	
Fail-safe element:	backup fuse for ESX10-T <u>not required</u> because of the integral redundant fail-safe element
Terminals	
LINE+ / LOAD+ / 0V	
screw terminals	M4
max. cable cross section	
flexible with wire end ferrule w/wo plastic sleeve	0.5 - 10 mm ²
wire stripping length	10 mm
tightening torque (EN 60934)	1.5 - 1.8 Nm
<u>multi-lead connection</u>	
(2 identical cables)	
rigid/flexible	0.5 - 4 mm ²
flexible with wire end ferrule without plastic sleeve	0.5 - 2,5 mm ²
flexible with TWIN wire end ferrule with plastic sleeve	0.5 - 6 mm ²
Terminals	
aux. contacts	
screw terminals	M3
max. cable cross section	
flexible with wire end ferrule w/wo plastic sleeve	0.25 - 2.5 mm ²
wire stripping length	8 mm
tightening torque (EN 60934)	0.5 - 0.6 Nm
Housing material	moulded
Mounting	symmetrical rail to EN 50022-35x7.5
Ambient temperature	0...+50 °C (without condensation, see EN 60204-1)
Storage temperature	-40...+70 °C
Humidity	96 hrs/95 % RH/40 °C to IEC 60068-2-78, test Cab. climate class 3K3 to EN 60721
Vibration	3 g, test to IEC 60068-2-6 test Fc
Degree of protection	housing: IP20 EN 60529 terminals: IP20 EN 60529
EMC (EMC directive, CE logo)	emission: EN 61000-6-3 susceptibility: EN 61000-6-2
Insulation co-ordination (IEC 60934)	0.5 kV/2 pollution degree 2 re-inforced insulation in operating area
dielectric strength	max. DC 32 V (load circuit)
Insulation resistance (OFF condition)	n/a, only electronic disconnection
Approvals (ESX10-TA/-TB/-TD)	CE-logo UL 2367, File # E306740, Solid State Overcurrent Protectors UL 508, File # E322549
Approvals (ESX10-TA/-TB)	UL 1604, File # E320024 (class I, division 2, groups A, B, C, D) CSA C22.2 No: 14, File # 16186 CSA C22.2 No: 142, File # 16186 CSA C22.2 No: 213 (class I, division 2)
Dimensions (W x H x D)	12.5 x 80 x 83 mm
Mass	approx. 65 g

Ordering configuration for ATEX versions: ...-E

Type No.	ESX10	Electronic Circuit Protector, with current limitation
Mounting and design		
TA	rail mounting, without signal contact	
TB	rail mounting, with signal contact and slot for busbars and jumpers	
Version		
1	standard, without physical isolation	
Signal input		
0	without signal input	
1	with control input IN+	
2	with reset input RE,	
Signal outputs		
0	without signal output	
1	signal contact N/O	
2	signal contact N/C	
4	status output SF	
7	inverse status output SF	
Operating voltage		
DC 24 V	rated voltage DC 24 V	
Current rating		
0.5...12 A		
Approvals		
E	ATEX	

ESX10 - TB-1 0 1- DC 24 V- 6 A -E Ordering information

Table 1: voltage drop, current limitation, max. load current

current rating I_N	typically voltage drop U_{ON} at I_N	active current limitation I_{Limit} (typically)	max. load current at 100% ON duty	
			$T_a = 40^\circ C$	$T_a = 50^\circ C$
0.5 A	70 mV	$1.8 \times I_N$	0.5 A	0.5 A
1 A	80 mV	$1.8 \times I_N$	1 A	1 A
2 A	130 mV	$1.8 \times I_N$	2 A	2 A
3 A	80 mV	$1.8 \times I_N$	3 A	3 A
4 A	100 mV	$1.8 \times I_N$	4 A	4 A
6 A	130 mV	$1.8 \times I_N$	6 A	5 A
8 A	120 mV	$1.5 \times I_N$	8 A	7 A
10 A	150 mV	$1.5 \times I_N$	10 A	9 A
12 A	180 mV	$1.3 \times I_N$	12 A	10,8 A
[0.5/1/2 A]	70/80/130 mV	$1.4 \times I_N$	0.5/1/2 A	0.5/1/2 A
[2/3/4 A]	130/80/100 mV	$1.4 \times I_N$	2/3/4 A	2/3/4 A
[2/4/6 A]	130/100/130 mV	$1.4 \times I_N$	2/4/6 A	2/4/5 A
[6/8/10 A]	130/120/150 mV	$1.4 \times I_N$	6/8/10 A	5/7/9 A

Attention:

when mounted side-by-side without convection the ESX10-T should not carry more than 80 % of its rated load with 100 % ON duty due to thermal effects.

Preferred types

NEW

Preferred types	Standard current ratings (A)											
	0.5	1	2	3	4	6	8	10	12	0.5 / 1 / 2	2 / 4 / 6	6 / 8 / 10
ESX10-TA/TB												
ESX10-TA-100-DC24V-	x	x	x	x	x	x	x	x	x			
ESX10-TB-101-DC24V-	x	x	x	x	x	x	x	x	x			
ESX10-TD												
ESX10-TD-101-DC24V-										x	x	x

Ordering information

Type No.	ESX10	Electronic Circuit Protector, with current limitation
Mounting and design		
TA	rail mounting, without signal contact	
TB	rail mounting, with signal contact and slot for busbars and jumpers	
TD	rail mounting, with signal contact and switch for 3-step current rating adjustment	
Version		
1	standard, without physical isolation in the event of a failure	
Signal input		
0	without signal input	
1	with control input IN+, only ESX10-T-114	
2	with reset input RE, only ESX10-T-124, ESX10-T-127	
Signal outputs		
0	without signal output (only ESX10-TA)	
1	signal contact N/O	
2	signal contact N/C	
4	status output SF (only ESX10-T-114, ESX10-T-124)	
7	inverse status output SF (only ESX10-T-127)	
Operating voltage		
DC 24 V	rated voltage DC 24 V	
Current rating		
0.5 A		
1 A		
2 A		
3 A		
4 A		
6 A		
8 A		
10 A		
12 A		
0.5/1/2 A	adjustable (only ESX10-TD-...-X278)	
2/4/6 A	adjustable (only ESX10-TD-...-X279)	
6/8/10 A	adjustable (only ESX10-TD-...-X280)	
2/3/4 A	adjustable (only ESX10-TD-101-...-X282)	

ESX10 - TA 1 0 0 - DC 24 V -6 A ordering example

Description of ESX10-T signal inputs and outputs see wiring diagrams.

Notes

- The user should ensure that the cable cross sections of the relevant load circuit are suitable for the current rating of the ESX10-T used.
- Automatic start-up of machinery after shut down must be prevented (Machinery Directive 98/37/EG and EN 60204-1). In the event of a short circuit or overload the load circuit will be disconnected electronically by the ESX10-T.

Table 2: ESX10-T - product version

Version	Signal input			Signal output						
				Signal output F (Signal contact)			Status output SF			
ESX10-..		without	Control input ON/OFF +24 V Control IN+	Reset input +24 V ↓RE	without	single signal N/O (normally open NO)	single signal N/C (normally closed NC)	without	Status OUT +24 V = OK	Status OUT 0 V = OK
-TA	-100	x			x			x		
-TB/-TD	-101	x				x		x		
-TB/-TD	-102	x					x	x		
-TB/-TD	-114		x						x	
-TB/-TD	-124			x	x				x	
-TB/-TD	-127			x	x					x

Terminal wiring diagram ESX10-TB-124 (Example)

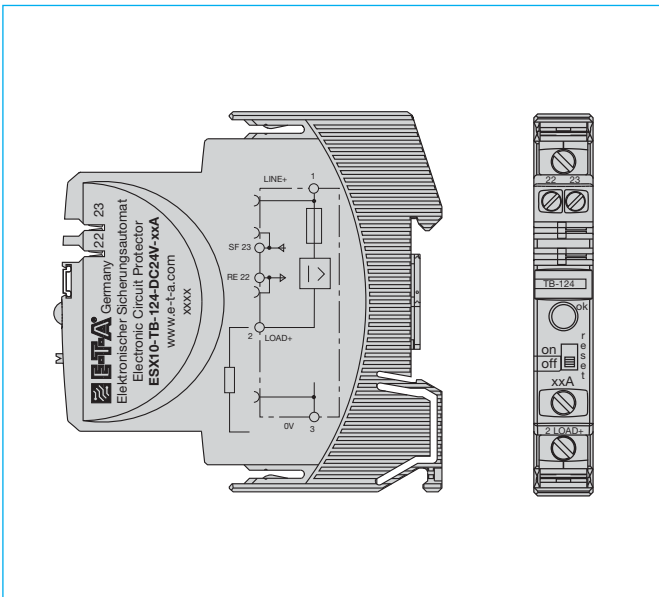

Schematic diagram ESX10-TB-124 (Example)

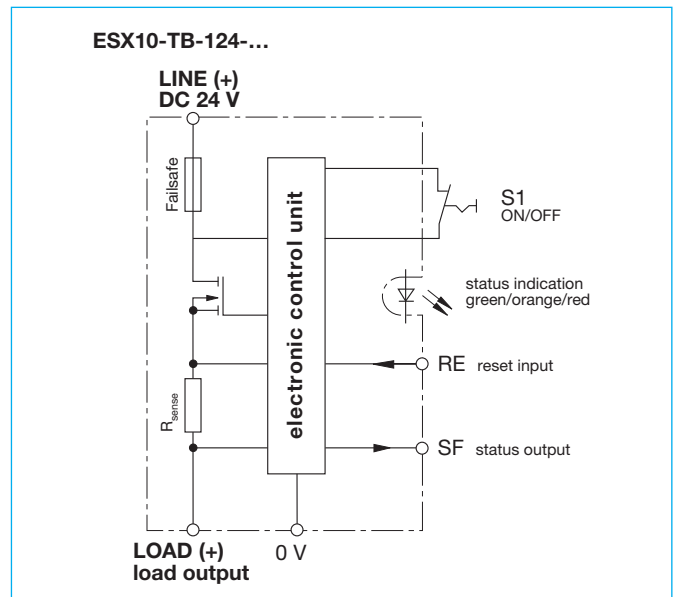

6

Approvals

ESX10-TA/-TB and -TD		
Authority	Voltage rating	Current ratings
UL 2367	DC 24 V	0.5...12 A
UL 508	DC 24 V	0.5...12 A
UL 1604 (class I, div. 2, groups A,B,C,D)	DC 24 V	0.5...12 A
CSA C22.2 No: 14	DC 24 V	0.5...12 A
CSA C22.2 No: 142	DC 24 V	0.5...12 A
CSA C22.2 No: 213 (class I, division 2)	DC 24 V	0.5...12 A
ESX10-TA and -TB		
Authority	Voltage rating	Current ratings
TÜV Süd/ATEX approval	DC 24 V	0.5...12 A
IEC/EN 60079-0/-14/-15	⊕ II 3G Ex nA IIB T4 Gc X	

EG-declaration of Conformity for ATEX-version ESX10-TA/-TB-...-E



EG-Konformitätserklärung Nr. 100.218.1016-01
Declaration of Conformity

Wir **E-T-A Elektrotechnische Apparate GmbH**
Wir (Name des Anbieters / supplier's name)

Industriestraße 2-8
D-90518 Altdorf
Germany

erklären in alleiniger Verantwortung, dass das Produkt
declare under our sole responsibility that the single pole product

elektronischer Sicherungsautomat
electronic circuit protector

- ESX10 (Steckmontage plug-in mounting, DC24V)
- ESX10-TA (Hutschienenmontage rail mounting, DC24V)
- ESX10-TB (Hutschienenmontage rail mounting, DC24V)

auf das sich diese Erklärung bezieht, mit der/den folgenden
Norm(en) oder normativen Dokument(en) übereinstimmt
to which this declaration relates is in conformity with the following standard(s) or
other normative document(s).

- EN 60079-0: 2009, Explosive Atmosphäre- Allgemeine Anforderungen
Explosive atmospheres - General requirements
- EN 60079-15: 2011, Explosive Atmosphäre - Geräteschutz durch
Zündschutzart „n“
Explosive atmospheres - Equipment protection by type of protection "n"

gemäß den Bestimmungen der Richtlinie(n)
Following the provisions of Directive(s) (falls zutreffend / if applicable)

- 94/9/EG ATEX-Richtlinie
- 94/9/EG ATEX directive

und der bestimmungsgemäßen Verwendung in explosionsgefährdeten
Bereichen entspricht.
and meets the requirements of intended use in explosive areas

II 3G Ex nA IIB T4 Gc X 0°C<STAS<+50°C
für Zone 2 (Gas-Atmosphäre)
for zone 2 (gas atmosphere)

Diese Konformitätserklärung entspricht der Europäischen Norm DIN EN ISO/IEC 17050-1:2010 "Konformitätsbewertung - Konformitätserklärung vom Anbieters - Teil 1: Allgemeine Anforderungen" und der internationalen Norm, ISO/IEC 17050-1:2004, Conformity assessment - Supplier's declaration of conformity - Part 1: General requirements.

This Declaration of Conformity is suitable to the European Standard DIN EN ISO/IEC 17050-1:2010 "Conformity assessment - Supplier's declaration of conformity - Part 1: General requirements" and the international Standard ISO/IEC 17050-1:2004, Conformity assessment - Supplier's declaration of conformity - Part 1: General requirements.



Die zugehörige Betriebsanleitung enthält wichtige sicherheitstechnische Hinweise und Vorschriften für die Inbetriebnahme der genannten Geräte gemäß der Richtlinie 94/9/EG (ATEX)
The pertinent user manual holds vital safety-related information and regulations for start-up of the described devices in accordance with directive 94/9/EG (ATEX).

Werden die Produkte in eine übergeordnete Maschine/Anlage eingebaut, so müssen die durch den Einbau entstehenden neuen Risiken durch den Hersteller der neuen Maschine /Anlage beurteilt werden.
Should the products be fitted into a superordinate machine or system, the newly developing risks have to be assessed by the manufacturer of the new machine/system.

Altdorf, 27. Oktober 2011

(Ort und Datum der Ausstellung /
Place and date of issue)

(Name und Unterschrift oder gleichwertige Kon-
sicherung des Befugten / name and signature
or equivalent of authorized person)

Dimensions ESX10-TA

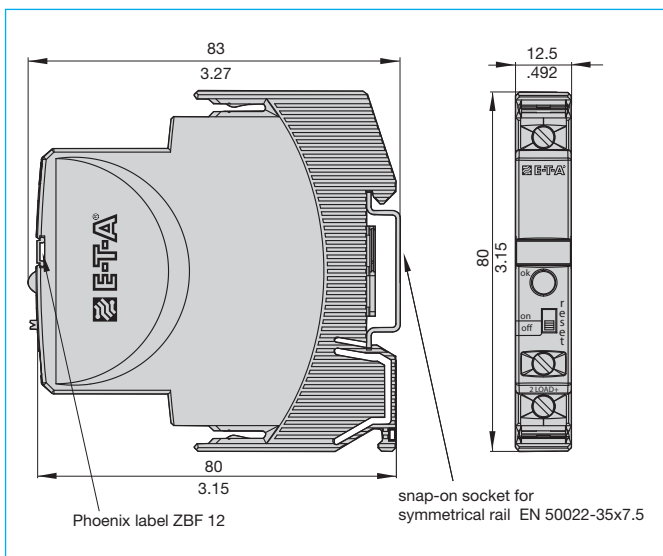

Dimensions ESX10-TB

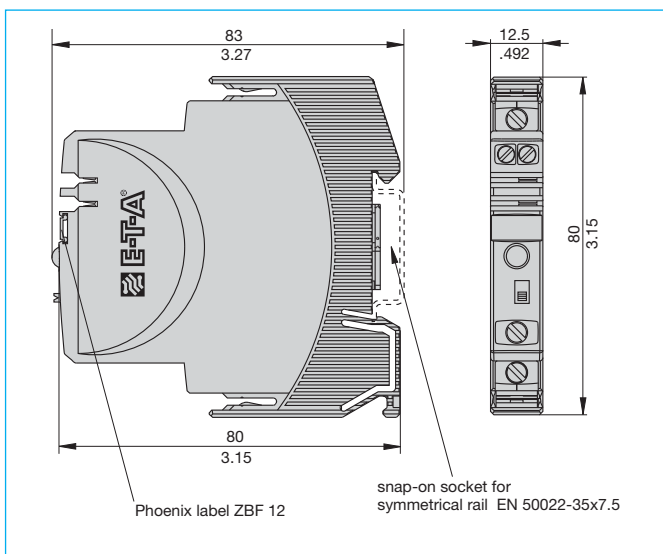

Dimensions ESX10-TD

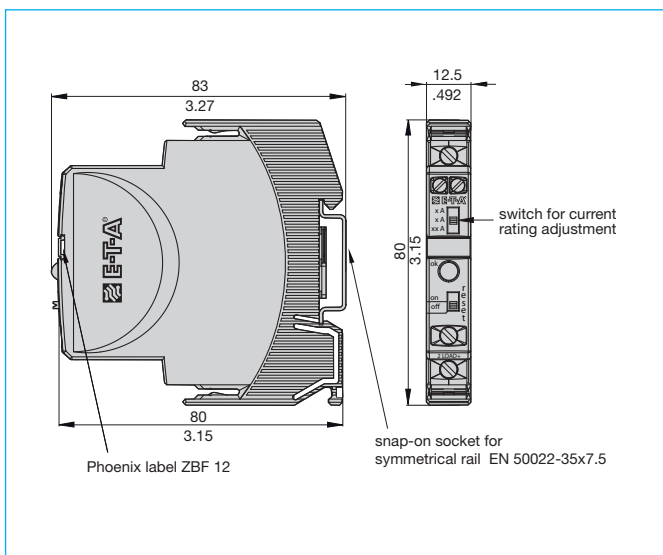

Information on UL approvals/CSA approvals

UL® ESX10-TA/-TB
UL1604
UL File # E320024

Operating Temperature Code T5

- This equipment is suitable for use in Class I, Division 2, Groups A, B, C and D or non-hazardous locations only

WARNING:

- Exposure to some chemicals may degrade the sealing properties of materials used in the following device: relay

Sealant Material:

Generic Name: Modified diglycidyl ether of bisphenol A
Supplier: Fine Polymers Corporation
Type: Epi Fine 4616L-160PK

Casing Material:

Generic Name: Liquid Crystal Polymer
Supplier: Sumitomo Chemical
Type: E4008, E4009, or E6008

RECOMMENDATION:

- Periodically inspect the device named above for any degradation of properties and replace if degradation is found

WARNING – EXPLOSION HAZARD:

- Do not disconnect equipment unless power has been removed or the area is known to be non-hazardous
- Substitution of any components may impair suitability for Class I, Division 2

UL® ESX10-TA/-TB/-TD
UL2367
Non-hazardous use - UL File # E306740

UL® ESX10-TA/-TB/-TD
UL 508
Non-hazardous use - UL File # E322549

CSA® ESX10-TA/-TB
CSA C22.2 No: 14 - File # 16186
CSA C22.2 No: 142 - File # 16186
CSA C22.2 No: 213 (Class I, Division 2) File # 16186

Class 2

Meets requirement for Class 2 current limitation
(ESX10-T...-0,5 A/1 A/2 A/3 A)

Instruction leaflet



Electronic Circuit Protector ESX10-T

UL® UL1604
UL File # E320024

CSA® C22.2 No.213
CSA File # 16186

This device is suitable for use in Class I, Div 2, Groups A, B, C, D; TC T5; Hazardous locations or nonhazardous locations only

Warnings:

1. Remove power before disconnecting device or the area is known to be nonhazardous.
2. Components substitutions may impair suitability of Class I, Div 2.
3. Chemical exposure may degrade internal relay's sealing property.

UL® UL2367
Non-hazardous use
UL File # E306740

UL® UL508
Non-hazardous use
UL File # E322549

CSA® C22.2 No.14
Non-hazardous use
CSA File # 16186

Refer to data sheet / installation guidelines for installation and safety instructions.

E-T-A Elektrotechnische Apparate GmbH
D-90518 Altdorf · Industriestraße 2-8
Tel. +49 9187 10-0 · Fax +49 9187 10-397
E-Mail: info@e-t-a.de · www.e-t-a.com/e

ESX10-T Signal inputs / outputs (wiring diagram)

ESX10-T signal inputs / outputs (schematic diagrams)

Auxiliary contacts are shown in OFF or error condition

ESX10-TA-100
without signal input/output

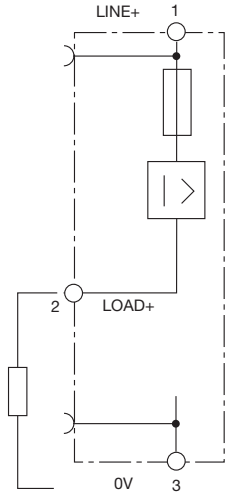

ESX10-TB-101
without signal input
with signal output F
(single signal, N/O)

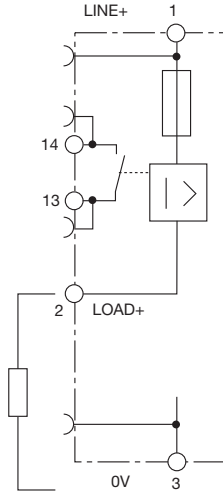

operating condition: 13-14 closed
fault condition: 13-14 open

ESX10-TB-102
without signal input
with signal output F
(single signal, N/C)

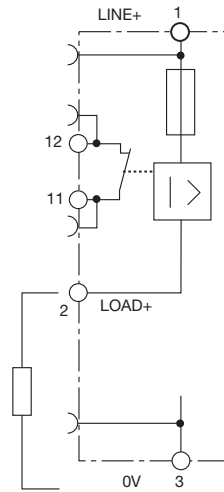

operating condition: 11-12 open
fault condition: 11-12 closed

ESX10-TB-114
with control input IN+
(+DC 24 V)
with status output SF
(+24 V = load output ON)

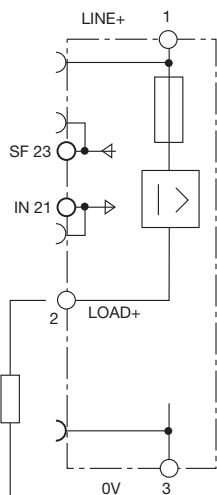

operating condition: SF +24 V = OK
fault condition: SF 0 V

ESX10-TB-124
with reset input RE
(+DC 24 V ↓)
with status output SF
(+24 V = load output ON)

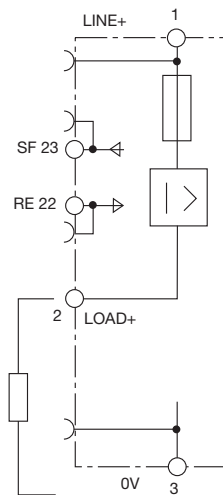

operating condition: SF +24 V = OK
fault condition: SF 0 V

ESX10-TB-127
with reset input RE
(+DC 24 V ↓)
with inverse status output SF
(0 V = load output ON)

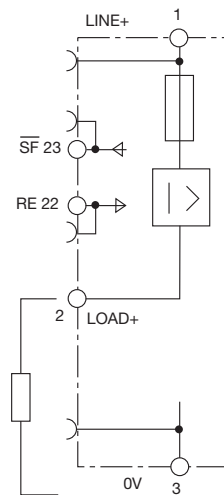

operating condition: SF 0 V = OK
fault condition: SF +24 V

ESX10-TD

Schematic diagram similar to ESX10-TB, without signal busbars (on top)

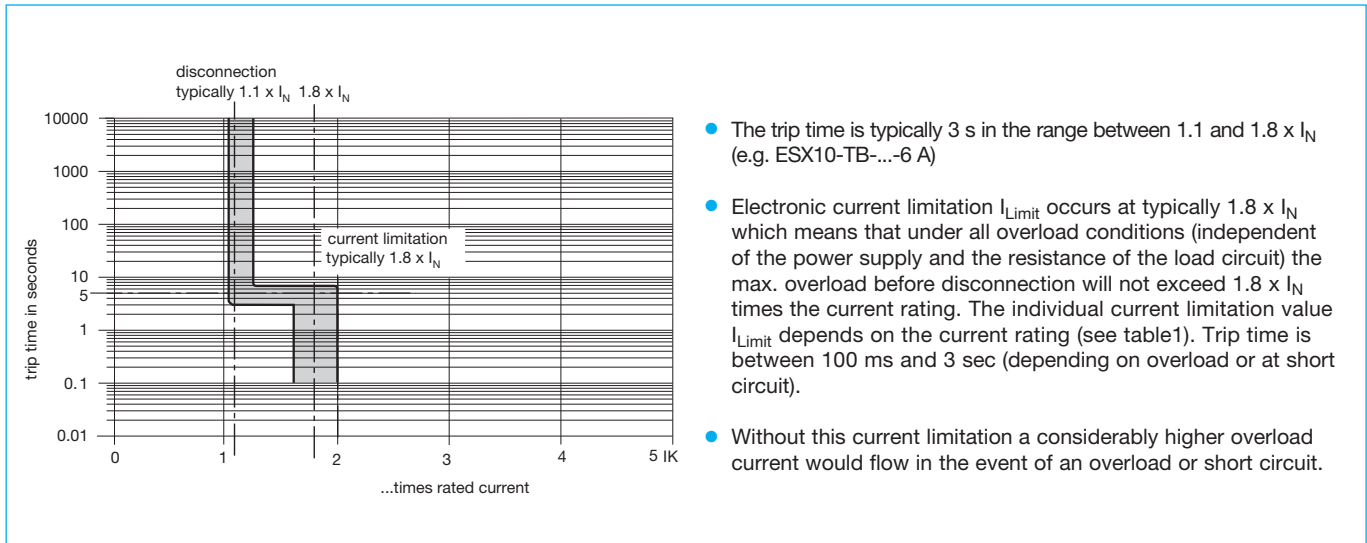
Time/Current characteristic curve ($T_A = 25\text{ }^\circ\text{C}$)

Table 3: Reliable trip of ESX10-T

Reliable trip of ESX10 with different cable lengths and cross sections							
Resistivity of copper $\rho_0 = 0.0178$ (Ohm x mm ²) / m							
$U_S = \text{DC } 19.2 \text{ V}$ (= 80 % of 24 V)	voltage drop of ESX10-T and tolerance of trip point (typically 1.1 x $I_N = 1.05 \dots 1.35 \times I_N$) have been taken into account.						
ESX10-T-selected rating I_N (in A) →	3	6					
e. g. trip current $I_{ab} = 1.25 \times I_N$ (in A) →	3.75	7.5	→ ESX10-T trips after 3 s				
R_{max} in Ohm = $(U_S / I_{ab}) - 0.050$ →	5.07	2.51					
The ESX10-T reliably trips from 0 Ohm to max. circuitry resistance R_{max}							
Cable cross section A in mm ² →	0.14	0.25	0.34	0.5	0.75	1	1.5
cable length L in meter (= single length)	cable resistance in Ohm = $(R_0 \times 2 \times L) / A$						
5	1.27	0.71	0.52	0.36	0.24	0.18	0.12
10	2.54	1.42	1.05	0.71	0.47	0.36	0.24
15	3.81	2.14	1.57	1.07	0.71	0.53	0.36
20	5.09	2.85	2.09	1.42	0.95	0.71	0.47
25	6.36	3.56	2.62	1.78	1.19	0.89	0.59
30	7.63	4.27	3.14	2.14	1.42	1.07	0.71
35	8.90	4.98	3.66	2.49	1.66	1.25	0.83
40	10.17	5.70	4.19	2.85	1.90	1.42	0.95
45	11.44	6.41	4.71	3.20	2.14	1.60	1.07
50	12.71	7.12	5.24	3.56	2.37	1.78	1.19
75	19.07	10.68	7.85	5.34	3.56	2.67	1.78
100	25.34	14.24	10.47	7.12	4.75	3.56	2.37
125	31.79	17.80	13.09	8.90	5.93	4.45	2.97
150	38.14	21.36	15.71	10.68	7.12	5.34	3.56
175	44.50	24.92	18.32	12.46	8.31	6.23	4.15
200	50.86	28.48	20.94	14.24	9.49	7.12	4.75
225	57.21	32.04	23.56	16.02	10.68	8.01	5.34
250	63.57	35.60	26.18	17.80	11.87	8.90	5.93
Example 1:	max. length at 1.5 mm ² and 3 A → 214 m						
Example 2:	max. length at 1.5 mm ² and 6 A → 106 m						
Example 3:	mixed wiring: R1 = 40 m in 1.5 mm ² and R2 = 5 m in 0.25 mm ² : (Control cabinet – sensor/actuator level) R1 = 0.95 Ohm, R2 = 0.71 Ohm Total (R1 + R2) = 1.66 Ohm						

Mounting examples for ESX10-T

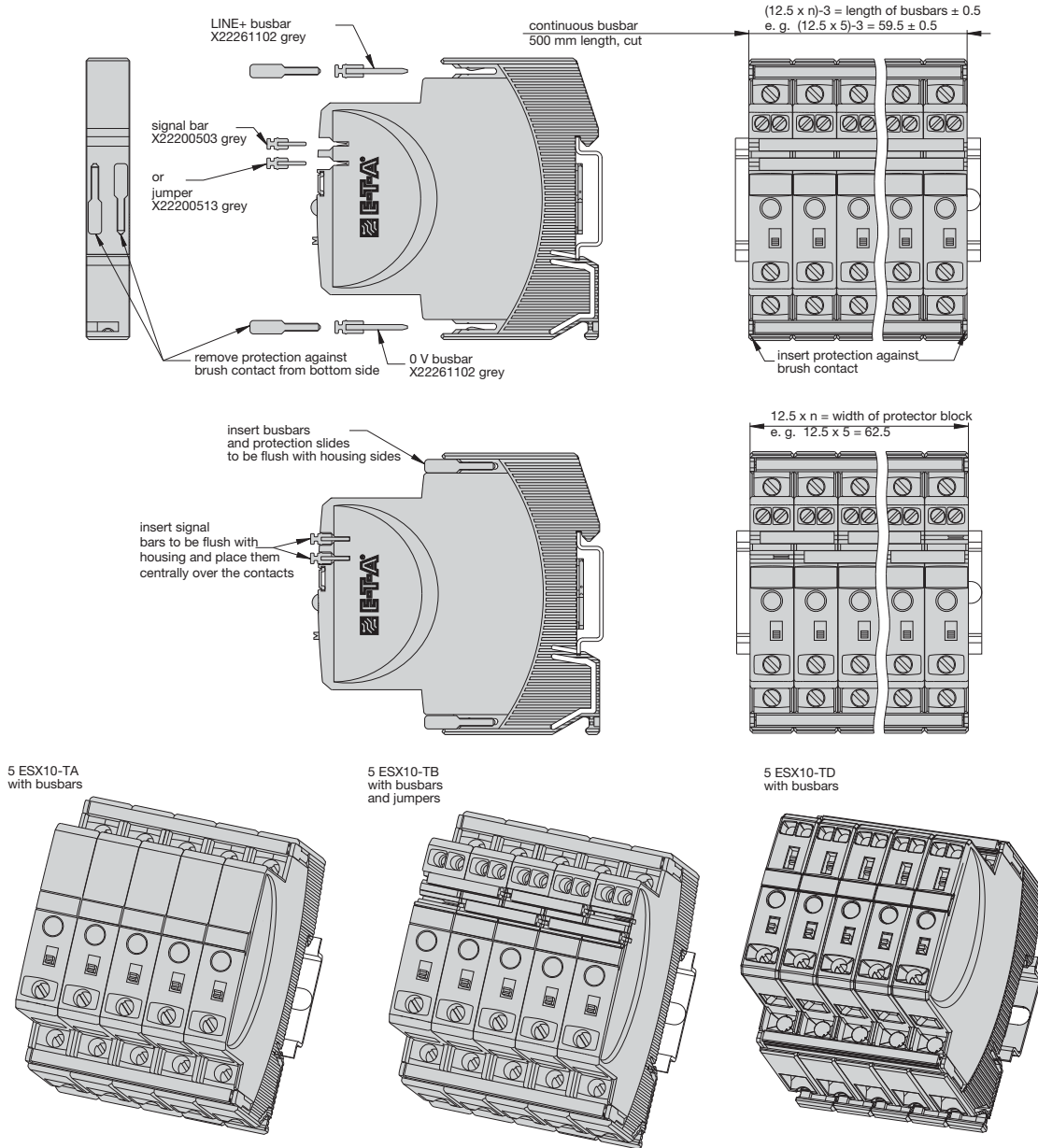
The ESX10-T features an integral power distribution system.



Mounting procedure:

Before wiring insert busbars into protector block.
Max. 10 insertion/removal cycles for busbars.

Recommendation:

After 10 units the busbars and signal busbars should be interrupted and receive a new entry live

Table of lengths for busbars

(X 222 611 02 / X 222 005 03 or cut off, see accessories)

No. of units	2	3	4	5	6	7	8	9	10
Length of busbar [mm] ± 0.5 mm	22	34.5	47	59.5	72	84.5	97	109.5	122

Connection diagrams and application examples ESX10-T

Connection diagrams and application examples ESX10-T...

Signal contacts are shown in OFF or fault condition.

ESX10-TA-100

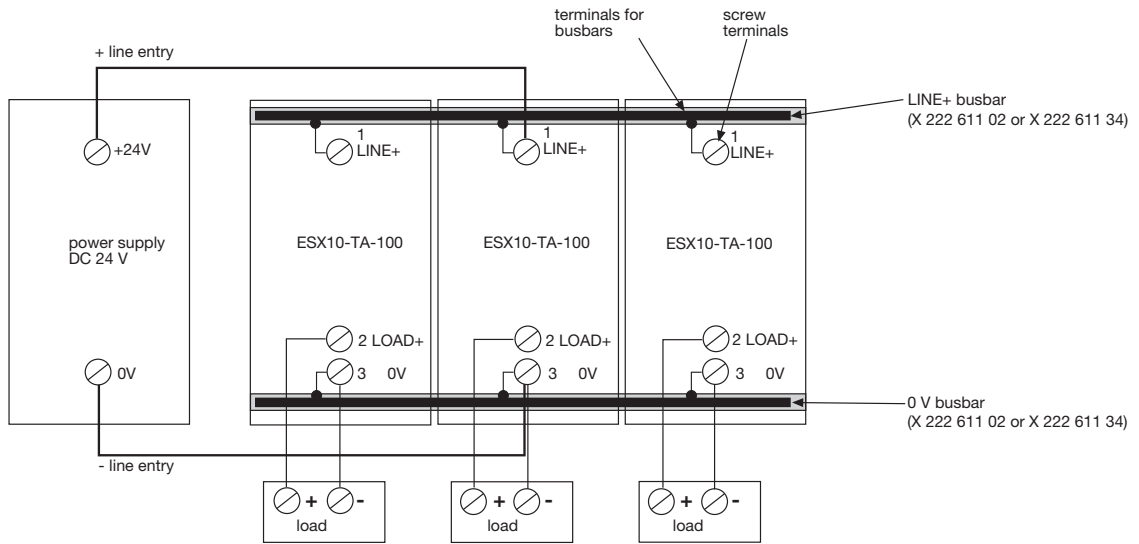

ESX10-TB-101

group signalling (series connection)

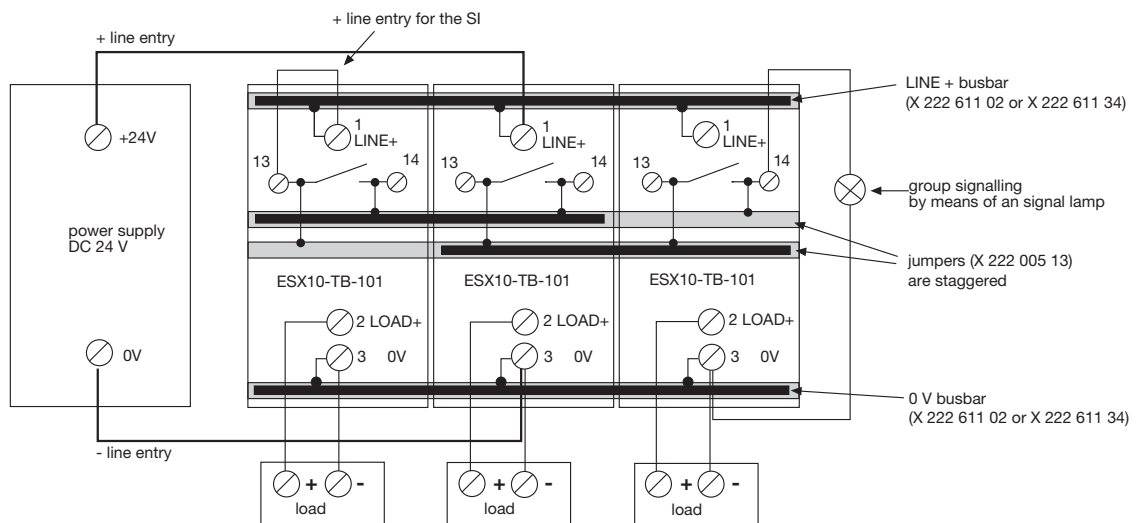

6

Connection diagrams and application examples ESX10-T

ESX10-TB-102

Single signalling with common line entry

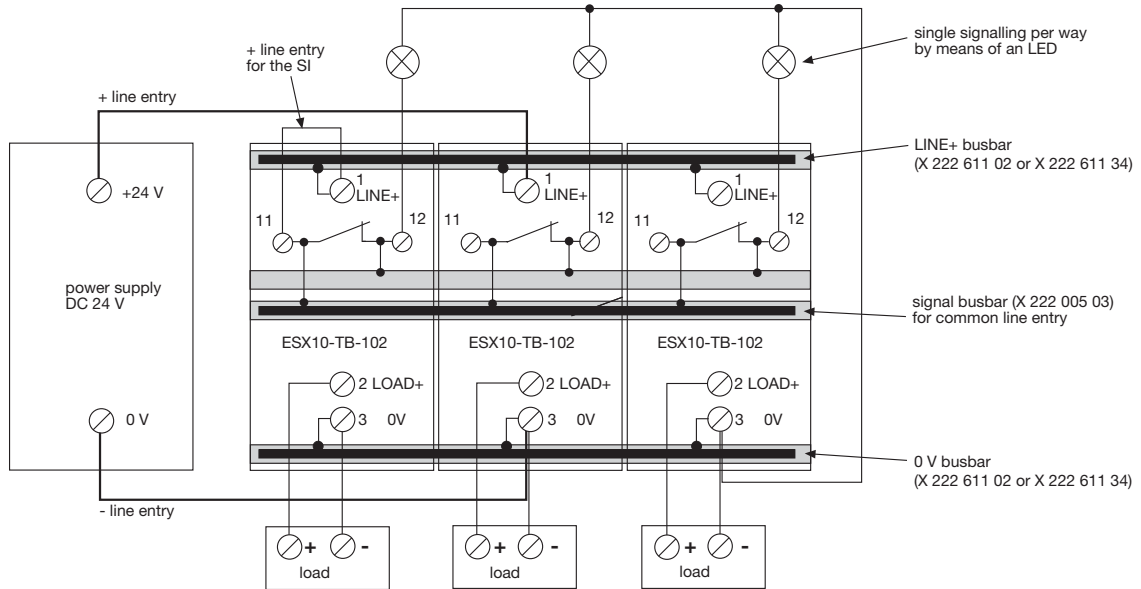

ESX10-TB-124

Single signalling with common reset

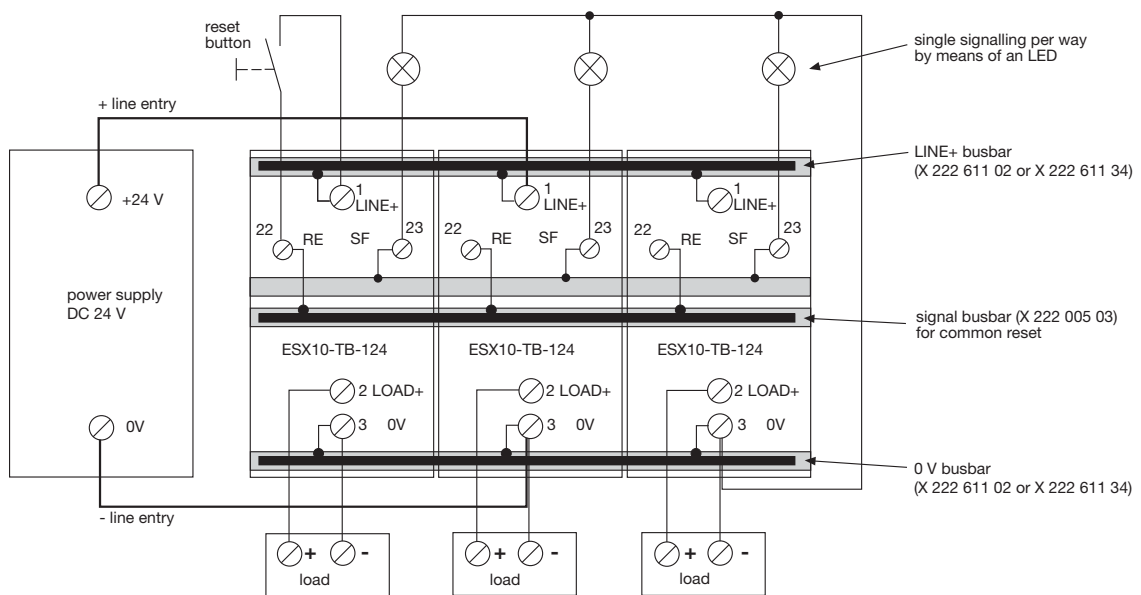

Connection diagrams and application examples ESX10-T

Applications examples: line entry DC 24 V with protection of signal circuit and direct connection of loads

Auxiliary contacts are shown on the OFF of fault condition

ESX10-TB-101

Group signalisation (series connection)

Type ESX10-TA-100-DC24V-0.5A can be used as a supply module including protection of auxiliary circuit

Optional: passive supply module AD-TX-EM01 (without protection)

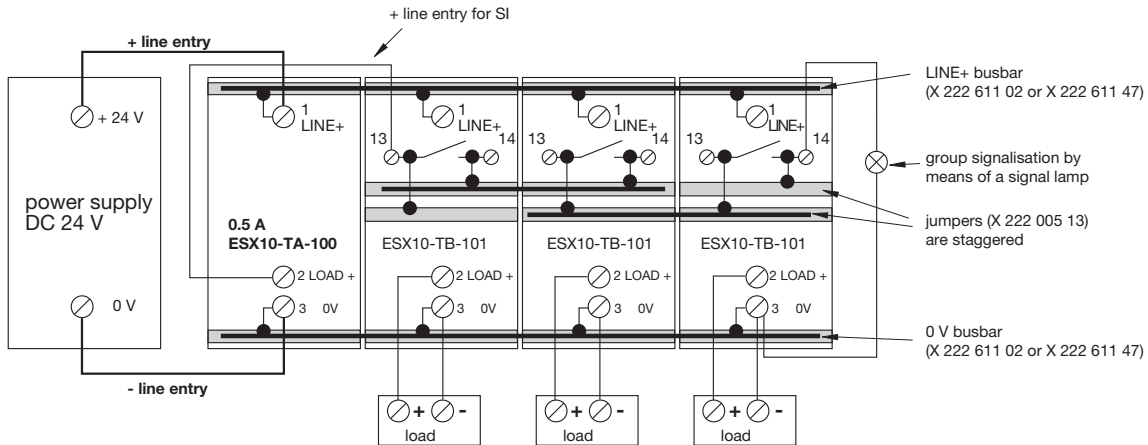

ESX10-TB-102

Single signalisation with common line entry

Type ESX10-TA-100-DC24V-0.5A can be used as a supply module including protection of auxiliary circuit

Optional: passive supply module AD-TX-EM01 (without protection)

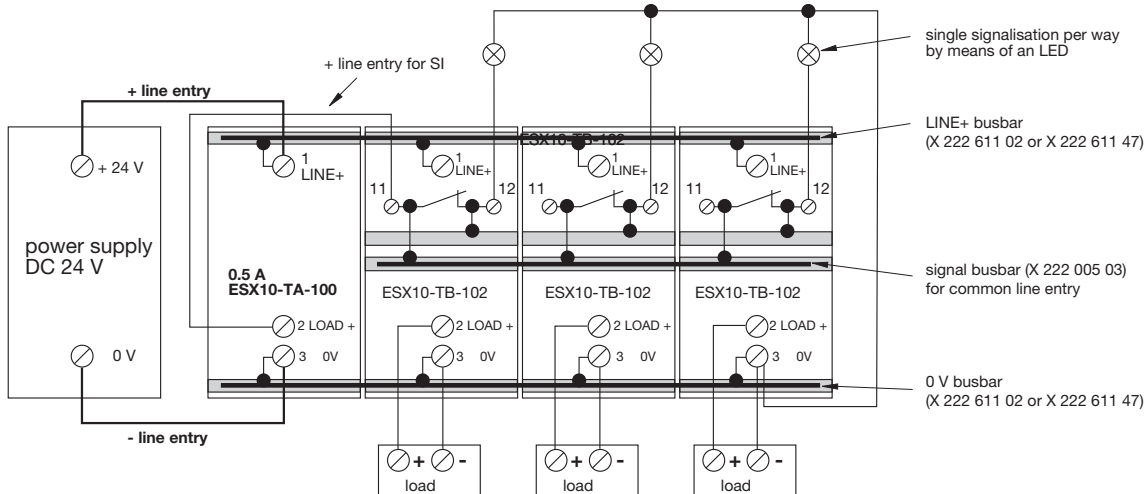

6

Description

The ESX10-T features an integral power distribution system. The following wiring modes are possible with various pluggable current and signal busbars:

- LINE +(DC 24 V)
- 0 V
- **Caution:** The electronic devices ESX10-T require a 0 V connection
- signal contacts
- reset inputs

Accessories

Busbars for LINE+ and 0 V

max. load with one line entry (recommended: centre line entry) I_{max} 50 A
 max. load with two line entries I_{max} 63 A
 grey insulation, length: 500 mm
X 222 611 02

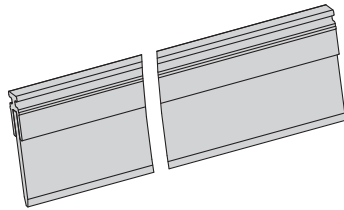

Jumpers for signal contacts

suitable for jumper ESX10-TB-...
 grey insulation, length: 21 mm
X 222 005 13
 packing unit: 10 pcs

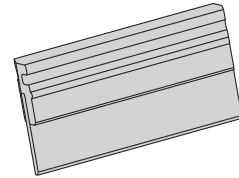

Busbars for LINE+ and 0 V

grey insulation
 max. number of plug-on operations 10:

X 222 611 22 (2-unit-block ESX10-T), length: 22 mm
X 222 611 34, (3-unit-block ESX10-T), length: 34.5 mm
X 222 611 47, (4-unit-block ESX10-T), length: 47 mm
X 222 611 59, (5-unit-block ESX10-T), length: 59.5 mm
 packing unit: 10 pcs

X 222 611 97, (8-unit-block ESX10-T), length: 97 mm
X 222 611 12, (10-unit-block ESX10-T), length: 122 mm
 packing unit: 4 pcs

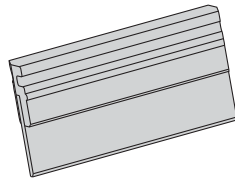

Insulated wire bridge

optional as jumper for ESX10-TB-101.../ESX10-TD-101...
 for group signalisation (series connection)
X 223 108 01
 packing unit: 10 pcs

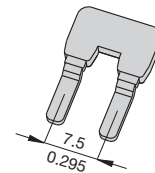

Signal busbars for signal contacts and reset inputs

suitable for signal busbar ESX10-TB-...
 max. load with one line entry
 with one series connection of signal contacts I_{max}
 grey insulation, length: 500 mm
X 222 005 03

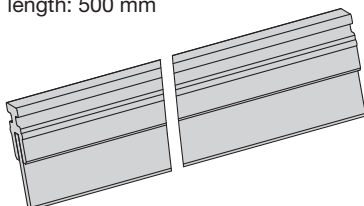

Connector bus link -K10

suitable for auxiliary contacts (series connection)
X 210 589 02 (1.5 mm², brown),

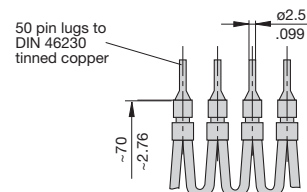

Accessories

Passive supply module for LINE+ and 0 V (without protection)

optional for all ESX10-T... versions in the event of loads to be connected directly to all ESX10-Ts.

capacity I_{max} 50 A
max. cross section 0,5 - 10 mm²

Technical data
see terminals ESX10-T

AD-TX-EM01

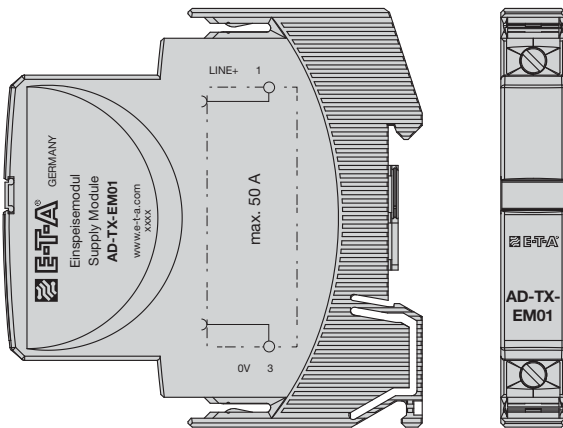

Labels, pack of 10

- suitable for ESX10-TD, cover of current rating adjustment
- Y 309 705 11** (0.5 A, 1 A, 2 A)
- Y 309 705 12** (2 A, 4 A, 6 A)
- Y 309 705 13** (6 A, 8 A, 10 A)
- Y 309 705 14** (2 A, 3 A, 4 A)

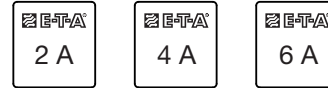

Labels, pack of 30

- suitable for ESX10-TD, cover of current rating adjustment
- Y 309 705 21** (0.5 A)
- Y 309 705 22** (1 A)
- Y 309 705 23** (2 A)
- Y 309 705 24** (3 A)
- Y 309 705 25** (4 A)
- Y 309 705 26** (6 A)
- Y 309 705 27** (8 A)
- Y 309 705 28** (10 A)

ESX10-TD-... application example for label

ESX10-TD-...

cover for current rating adjustment

