

ohne / without

Mutter / nut  
max. Einschraubtiefe 7.5 mm  
thread depth max. 7.5 mm

Bolzen / bolt  
max. Einschraubtiefe 5.5 mm  
thread depth max. 5.5 mm

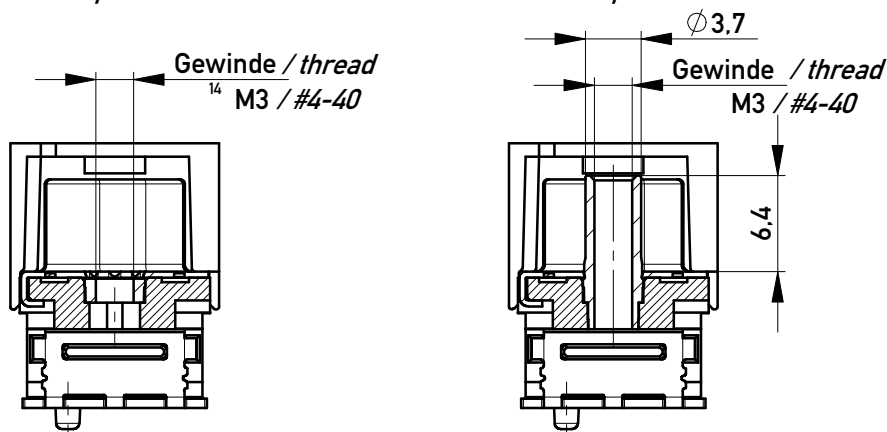
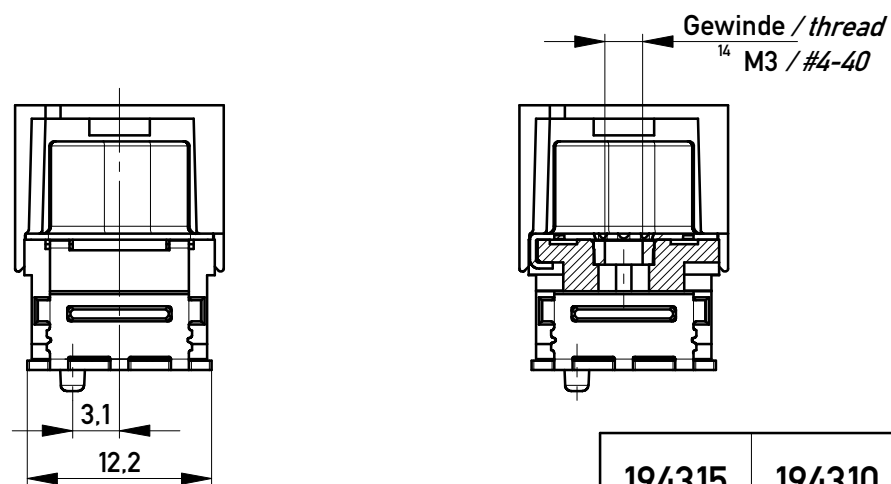

M 1:1

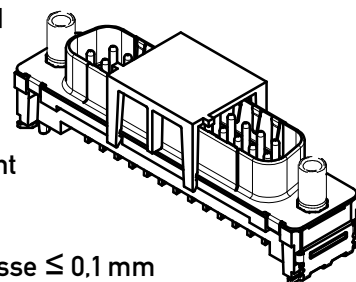

Anschlussbereich verzinkt  
terminal area tin plating

Koplanarität der Anschlüsse ≤ 0.1 mm  
coplanarity area of termination ≤ 0.1 mm

Anforderungsstufe: 2  
class: 2

194315	194310	X			
194316	194311			#4-40	
194317	194312			M3	
194318	194313		#4-40		
194319	194314		M3		
Ident.-Nr. part-no. tape & reel	Ident.-Nr. part-no. tray	ohne without	Mutter thread	Bolzen bolt	Bemerkung remark

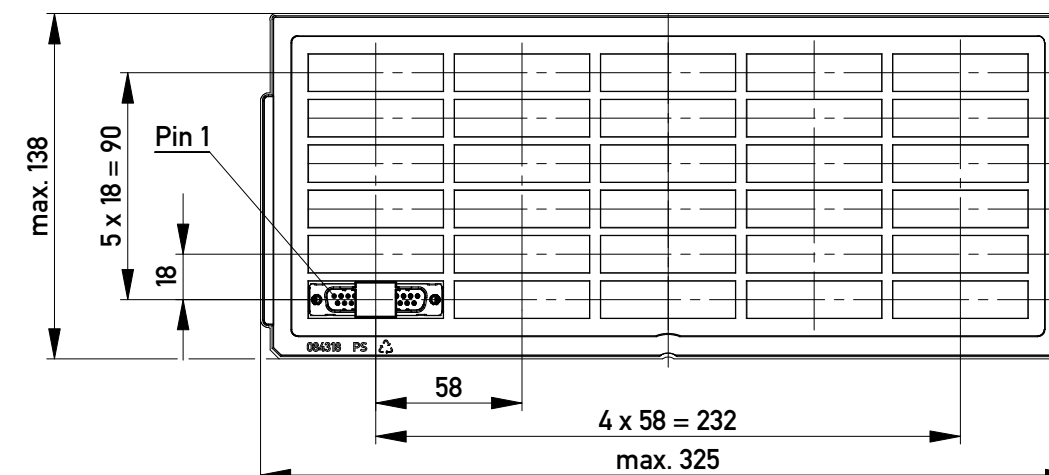

Verpackt in Tray  
Verpackungseinheit 30 St.  
tray packaging  
packaging unit 30 pcs

Sonstige Angaben siehe Zeichnung 204628 / Additional indications according to drawing 204628

Verpackt in Gurtverpackung - Tape on Reel Packaging  
Verpackungseinheit: 75 Stück - Packaging unit: 75 pcs

Abspulrichtung - Reel off Direction

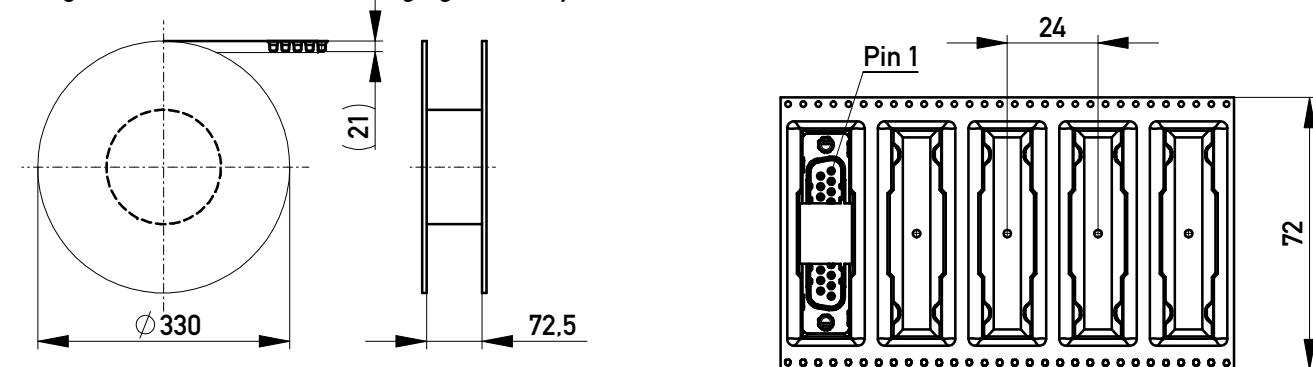

Sonstige Angaben siehe Zeichnung 204654 / Additional indications according to drawing 204654

Layoutvorschlag:  
recommended layout:

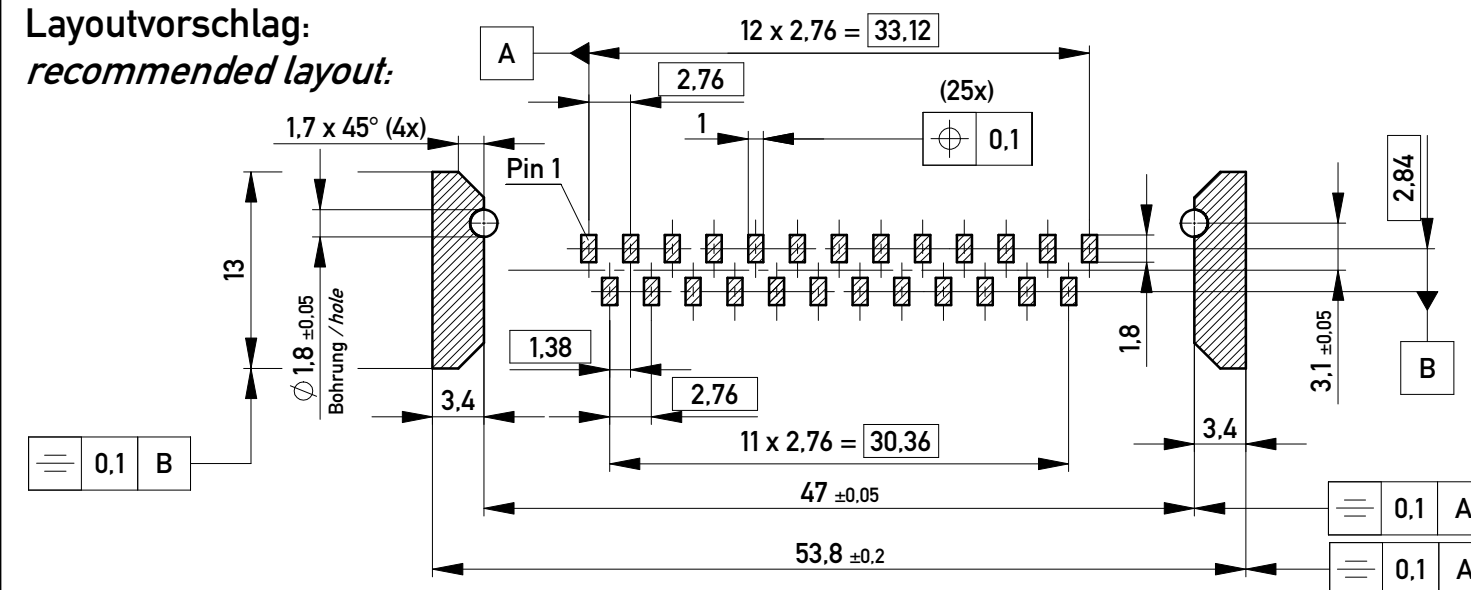

Fehlende Masse und Angaben siehe DIN 41652 / Missing information and dimensions according to DIN 41652  
Sonstige Angaben siehe Fertigungsunterlagen / Additional indications according to the production documentation

Information:	Tolerances	Scale 2:1
All rights reserved. Only for Information. To ensure that this is the latest version of this drawing, please contact one of the ERNI companies before using.	Subject to modification without prior notice. Drawing will not be updated.	Designation <b>TMC-P 25-SMD-9,0-BA8</b> <b>TMC-P 25-SMD-9,0-type 8</b>
g	04.02.2016	144909
Index	Date	Class TMCP
www.ERNI.com		A3