

Shielded Cable Termination Flexible Cable - Straight Crimp Type

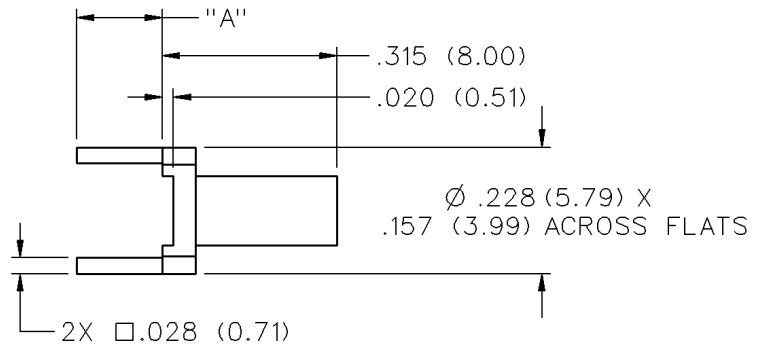

| CABLE TYPE | GOLD PLATED | NICKEL PLATED | "A" |
|------------------|--------------|---------------|-------------|
| RG-178/U, 196 | 142-0002-211 | 142-0002-216 | .155 (3.94) |

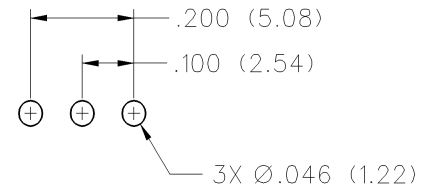
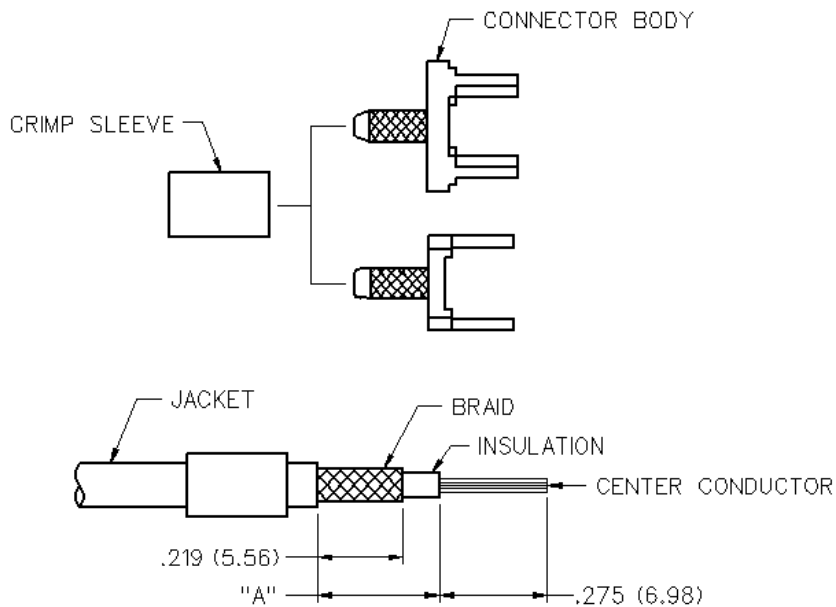

1. Identify connector parts. (2 piece parts)
2. Strip cable to dimensions shown. Do not nick braid or center conductor. A wire stripper of correct size is recommended for this step. Twist stranded center conductor into tight bundle and tin. Slide crimp sleeve onto cable as shown.
3. Flare braid and slide cable into body making certain that the cable insulation is flush with bottom of connector.
4. Arrange braid uniformly around crimp stem. Slide crimp sleeve over braid and crimp securely using recommended crimp tool.

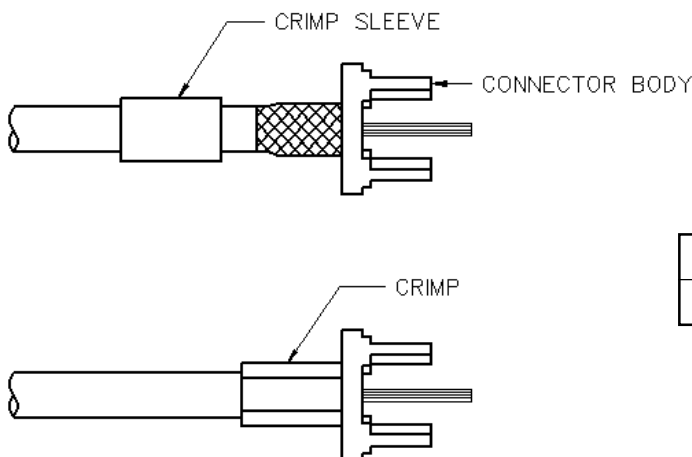

| CABLE GROUP | PART NUMBER | "A" | CRIMP HEX |
|---------------|------------------|-------------|-------------|
| RG-178/u, 196 | 142-0002-201/206 | .312 (7.92) | .105 (2.67) |