

REGULATORY COMPLIANCE

 COMPLIANT	 2011/65 + 2015/863 COMPLIANT	 COMPLIANT	 COMPLIANT	
---	---	--	--	---

ITEM DESCRIPTION

Quartz Crystal Clock Oscillators XO (SPXO) LVCMOS (CMOS) 3.3Vdc 4 Pad 5.0mm x 7.0mm Ceramic Surface Mount (SMD)

ELECTRICAL SPECIFICATIONS

Nominal Frequency	1.544MHz to 200MHz
Frequency Tolerance/Stability	Inclusive of all conditions: Calibration Tolerance at 25°C, Frequency Stability over the Operating Temperature Range, Supply Voltage Change, Output Load Change, First Year Aging at 25°C, Shock, and Vibration ±100ppm Maximum ±50ppm Maximum ±20ppm Maximum ±25ppm Maximum
Aging at 25°C	±5ppm/year Maximum
Operating Temperature Range	-10°C to +70°C -40°C to +85°C
Supply Voltage	3.3Vdc ±10%
Input Current	10mA Maximum over Nominal Frequency of 1.544MHz to 32MHz 18mA Maximum over Nominal Frequency of 32MHz to 50MHz 20mA Maximum over Nominal Frequency of 50.000001MHz to 70MHz 40mA Maximum over Nominal Frequency of 70.000001MHz to 125MHz 60mA Maximum over Nominal Frequency of 125.000001MHz to 200MHz
Output Voltage Logic High (VOH)	IOH = -8mA 90% of Vdd Minimum
Output Voltage Logic Low (VOL)	IOL = +8mA 10% of Vdd Maximum
Rise/Fall Time	Measured at 20% to 80% of waveform 5nSec Maximum (w/15pF Load) over Nominal Frequency of 1.544MHz to 35MHz 3nSec Maximum over Nominal Frequency of 35.000001MHz to 165MHz 2nSec Maximum over Nominal Frequency of 165.000001MHz to 200MHz
Duty Cycle	Measured at 50% of waveform 50 ±10(%) 50 ±5(%)
Load Drive Capability	15pF Maximum over Nominal Frequency of 1.544MHz to 200MHz
Output Logic Type	CMOS
Pin 1 Connection	Tri-State (High Impedance)
Output Control Input Voltage Logic High (Vih)	70% of Vdd Minimum or No Connect to Enable Output.
Output Control Input Voltage Logic Low (Vil)	30% of Vdd Maximum to Disable Output (High Impedance)
Standby Current	Disabled Output, High Impedance 10µA Maximum
RMS Phase Jitter 10-39 MHz >39 MHz	12kHz to 5MHz 12kHz to 20MHz 1pSec Maximum
Start Up Time	10mSec Maximum
Storage Temperature Range	-55°C to +125°C

PART NUMBERING GUIDE

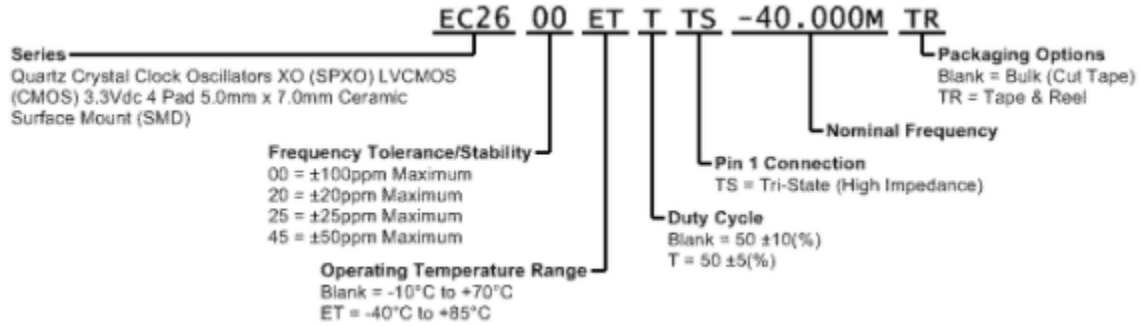

MECHANICAL DIMENSIONS

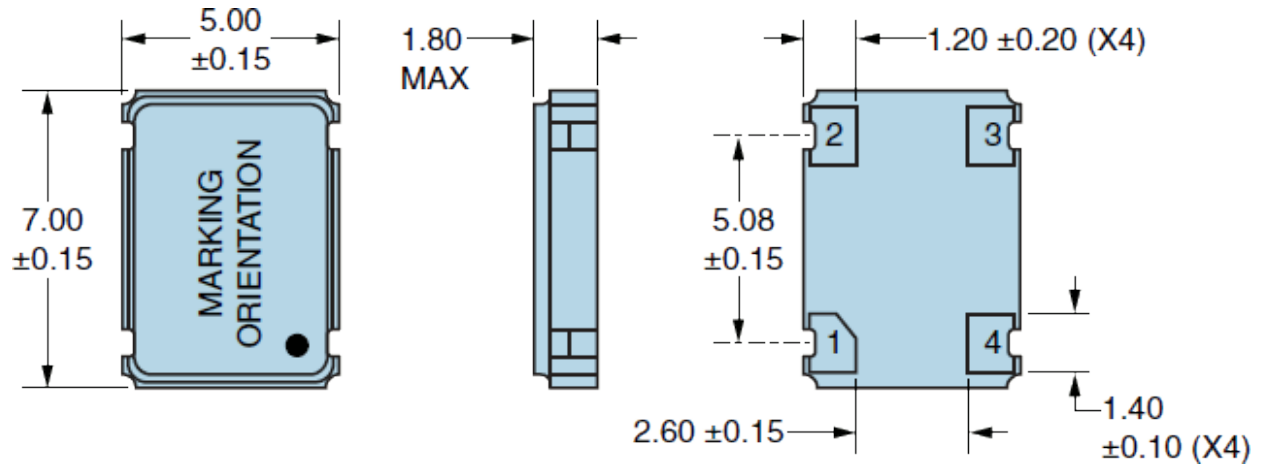

SUGGESTED SOLDER PAD LAYOUT

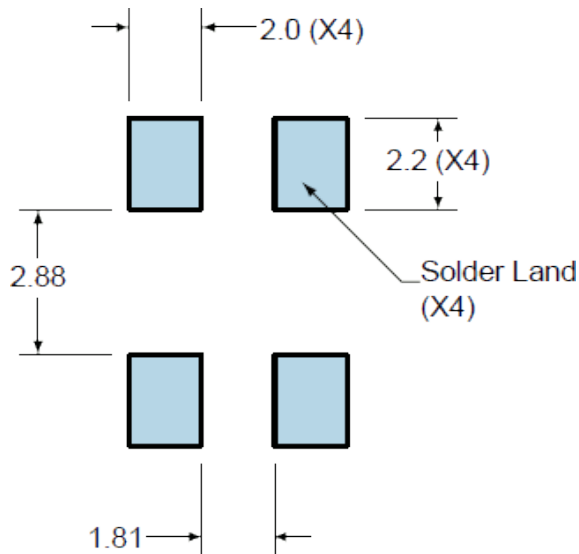

PIN	CONNECTION
1	Tri-State
2	Case/Ground
3	Output
4	Supply Voltage

All Tolerances are ±0.1

All Dimensions in Millimeters

OUTPUT WAVEFORM & TIMING DIAGRAM

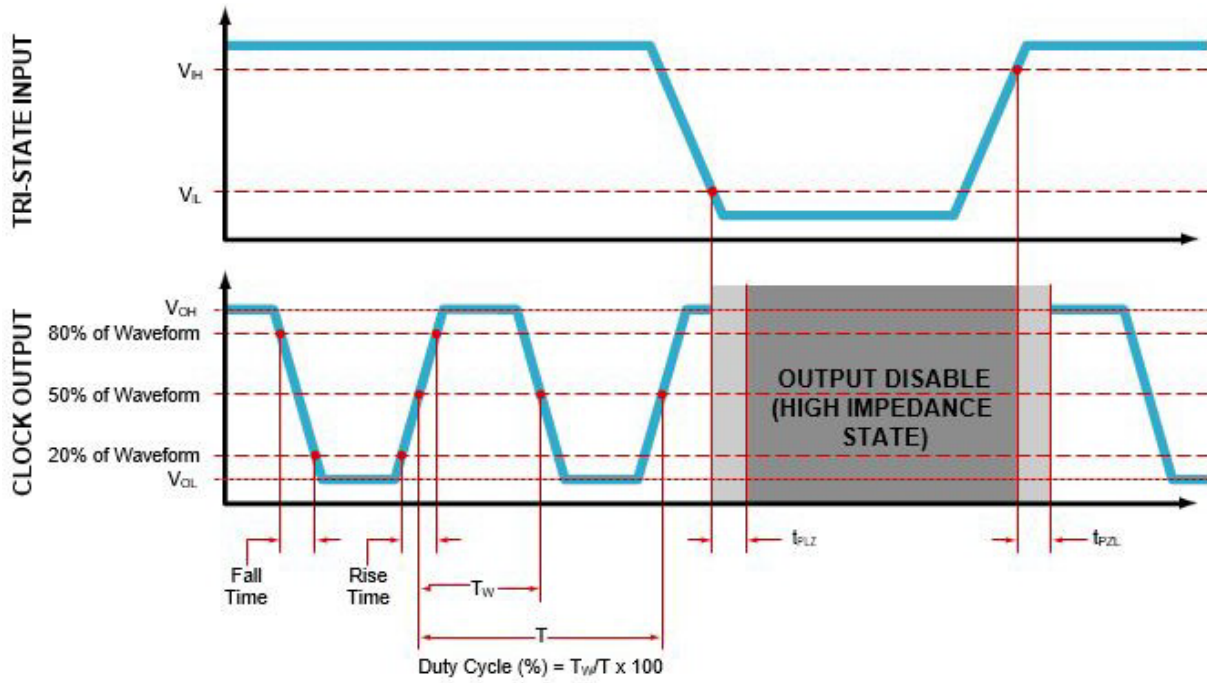

TEST CIRCUIT FOR CMOS OUTPUT

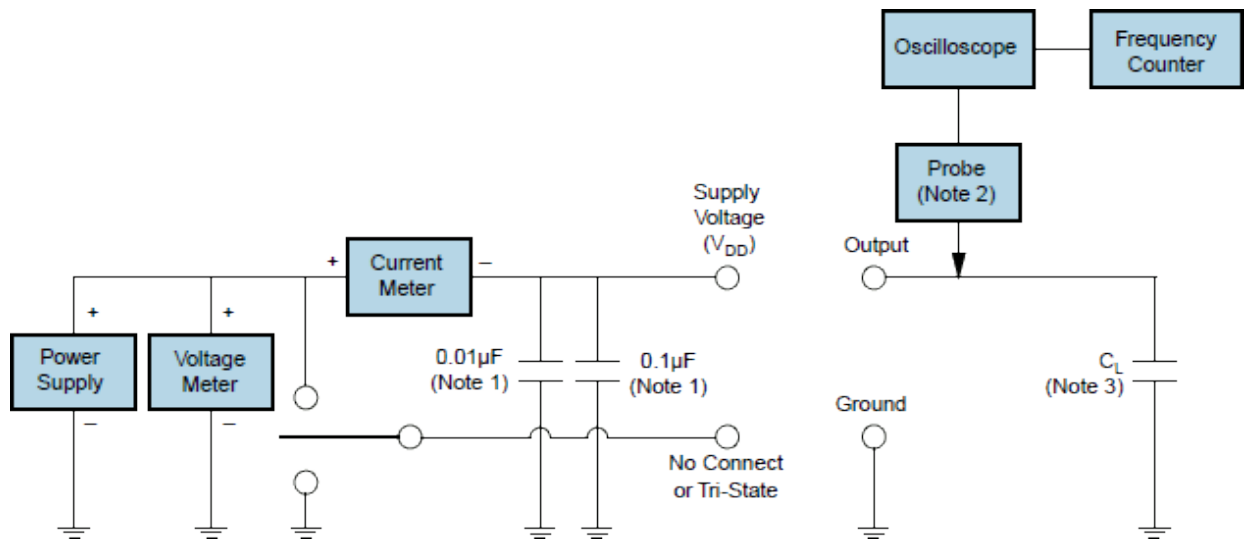

Note 1: An external $0.1\mu\text{F}$ low frequency tantalum bypass capacitor in parallel with a $0.01\mu\text{F}$ high frequency ceramic bypass Capacitor close to the package ground pin is required.

Note 2: A low input capacitance ($<12\text{pF}$), 10X Attenuation Factor, High Impedance ($>10\text{Mohms}$), and High bandwidth ($>300\text{MHz}$) Passive probe is recommended.

Note 3: Capacitance value (C_L) includes sum of all probe and fixture capacitance. See applicable specification sheet for 'Load Drive Capability'.

TAPE & REEL DIMENSIONS

Quantity per Reel: 1,000 Units

All Dimensions in Millimeters

Compliant to EIA-481

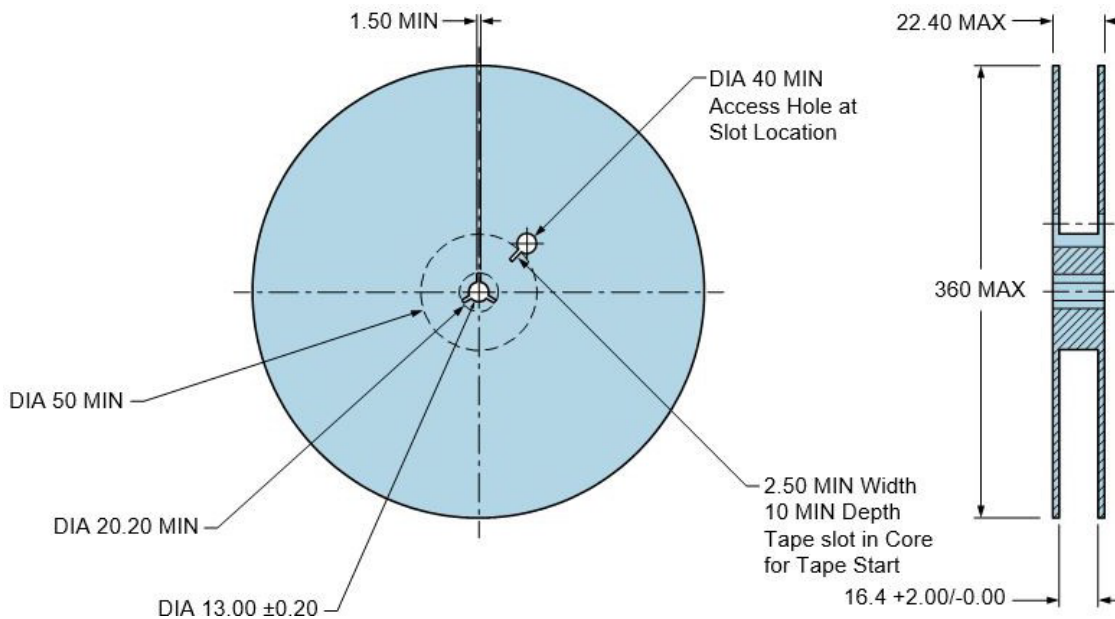
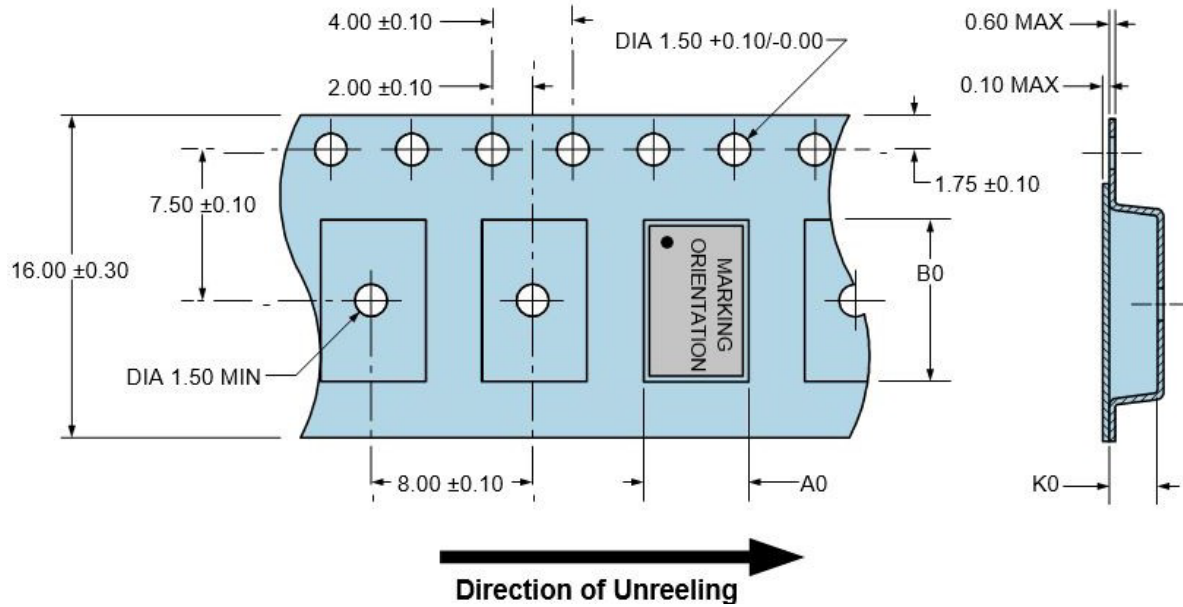

RECOMMENDED SOLDER REFLOW METHOD

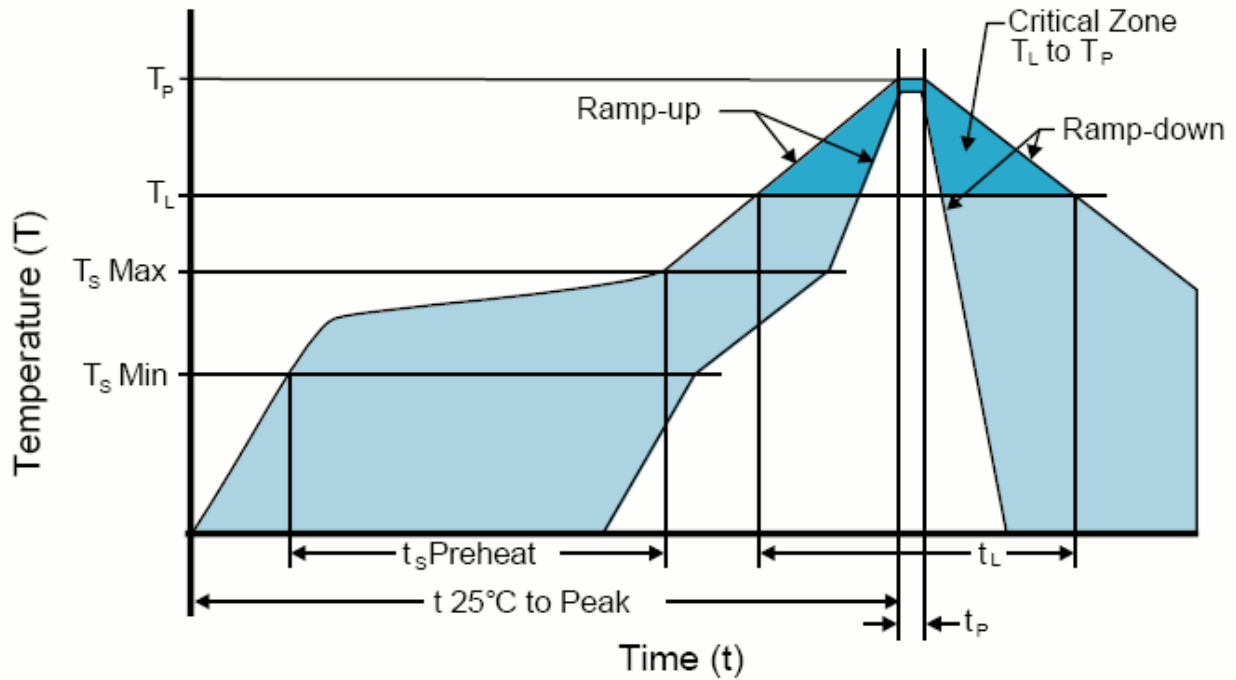

HIGH TEMPERATURE INFRARED/CONVECTION

T _S MAX to T _L (Ramp-up Rate)	3°C/Second Maximum
Preheat	
- Temperature Minimum (T _S MIN)	150°C
- Temperature Typical (T _S TYP)	175°C
- Temperature Maximum(T _S MAX)	200°C
- Time (t _s)	60 - 180 Seconds
Ramp-up Rate (T_L to T_P)	3°C/Second Maximum
Time Maintained Above:	
- Temperature (T _L)	217°C
- Time (t _L)	60 - 150 Seconds
Peak Temperature (T_P)	260°C Maximum for 10 Seconds Maximum
Target Peak Temperature(T_P Target)	250°C +0/-5°C
Time within 5°C of actual peak (t_p)	20 - 40 Seconds
Ramp-down Rate	6°C/Second Maximum
Time 25°C to Peak Temperature (t)	8 Minutes Maximum
Moisture Sensitivity Level	Level 1
Additional Notes	Temperatures shown are applied to body of device.

High Temperature Manual Soldering

260°C Maximum for 5 Seconds Maximum, 2 times Maximum. (Temperatures shown are applied to body of device.)

RECOMMENDED SOLDER REFLOW METHOD

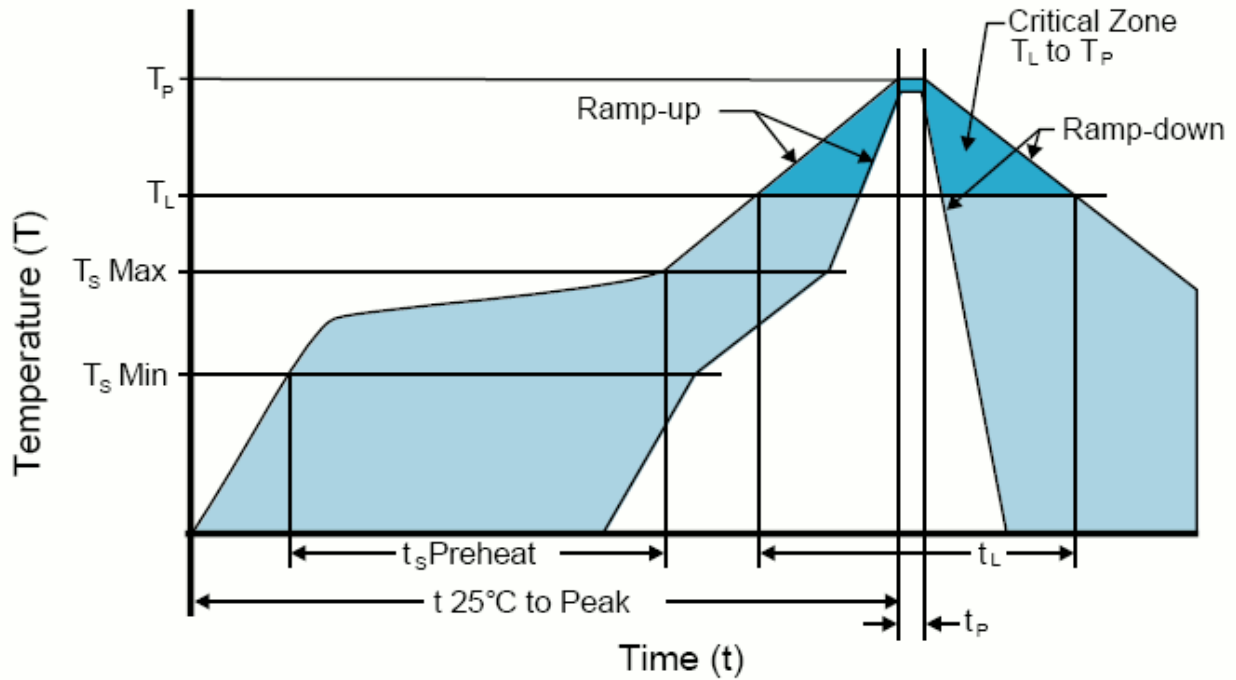

LOW TEMPERATURE INFRARED/CONVECTION	
T _s MAX to T _L (Ramp-up Rate)	5°C/Second Maximum
Preheat	
- Temperature Minimum (T _s MIN)	N/A
- Temperature Typical (T _s TYP)	150°C
- Temperature Maximum(T _s MAX)	N/A
- Time (t _s)	60 - 120 Seconds
Ramp-up Rate (T _L to T _P)	5°C/Second Maximum
Time Maintained Above:	
- Temperature (T _L)	150°C
- Time (t _L)	200 Seconds Maximum
Peak Temperature (T _P)	240°C Maximum
Target Peak Temperature (T _P Target)	240°C Maximum 2 Times / 230°C Maximum 1 Time
Time within 5°C of actual peak (t _p)	10 Seconds Maximum 2 Times / 80 Seconds Maximum 1 Time
Ramp-down Rate	5°C/Second Maximum
Time 25°C to Peak Temperature (t)	N/A
Moisture Sensitivity Level	Level 1
Additional Notes	Temperatures shown are applied to body of device.

Low Temperature Manual Soldering

185°C Maximum for 10 Seconds Maximum, 2 times Maximum. (Temperatures shown are applied to body of device.)