

**REGULATORY COMPLIANCE**

 <p><b>Lead Free</b> COMPLIANT</p>	 <p><b>EU RoHS</b> 2011/65 + 2015/863 COMPLIANT</p>	 <p><b>China RoHS</b> COMPLIANT</p>	 <p><b>REACH</b> SVHC COMPLIANT</p>	 <p><b>DRC</b> CONFLICT FREE</p>
--	--	--	--	---

**ITEM DESCRIPTION**

Automotive Grade Quartz Crystal Resonator 2.5mm x 3.2mm x 0.8mm 4 Pad Ceramic Surface Mount (SMD)

**ELECTRICAL SPECIFICATIONS**

<b>Nominal Frequency</b>	8MHz to 66MHz
<b>Frequency Tolerance/Stability</b>	±50ppm at 25°C, ±100ppm over -40°C to +85°C ±30ppm at 25°C, ±50ppm over -40°C to +85°C ±15ppm at 25°C, ±30ppm over -40°C to +85°C ±15ppm at 25°C, ±20ppm over -40°C to +85°C ±10ppm at 25°C, ±20ppm over -40°C to +85°C ±50ppm at 25°C, ±100ppm over -40°C to +105°C ±30ppm at 25°C, ±50ppm over -40°C to +105°C ±50ppm at 25°C, ±100ppm over -40°C to +125°C ±30ppm at 25°C, ±50ppm over -40°C to +125°C
<b>Aging at 25°C</b>	±3ppm/year Maximum
<b>Load Capacitance</b>	Series Resonant, 7pF Parallel Resonant to 32pF Parallel Resonant
<b>Shunt Capacitance</b>	3pF Maximum
<b>Equivalent Series Resistance</b>	800 Ohms Maximum over Nominal Frequency of 8MHz to 9.999999MHz 250 Ohms Maximum over Nominal Frequency of 10MHz to 10.999999MHz 150 Ohms Maximum over Nominal Frequency of 11MHz to 11.999999MHz 100 Ohms Maximum over Nominal Frequency of 12MHz to 12.999999MHz 80 Ohms Maximum over Nominal Frequency of 13MHz to 15.999999MHz 70 Ohms Maximum over Nominal Frequency of 16MHz to 20.999999MHz 60 Ohms Maximum over Nominal Frequency of 21MHz to 29.999999MHz 50 Ohms Maximum over Nominal Frequency of 30MHz to 66MHz
<b>Mode of Operation</b>	AT-Cut Fundamental
<b>Drive Level</b>	200µWatts Maximum
<b>Crystal Cut</b>	AT-Cut
<b>Spurious Response</b>	Measured from Fo to Fo +5000ppm -3dB Minimum
<b>Storage Temperature Range</b>	-50°C to +150°C
<b>Insulation Resistance</b>	Measured at 100Vdc 500 Megaohms Minimum

**PART NUMBERING GUIDE**

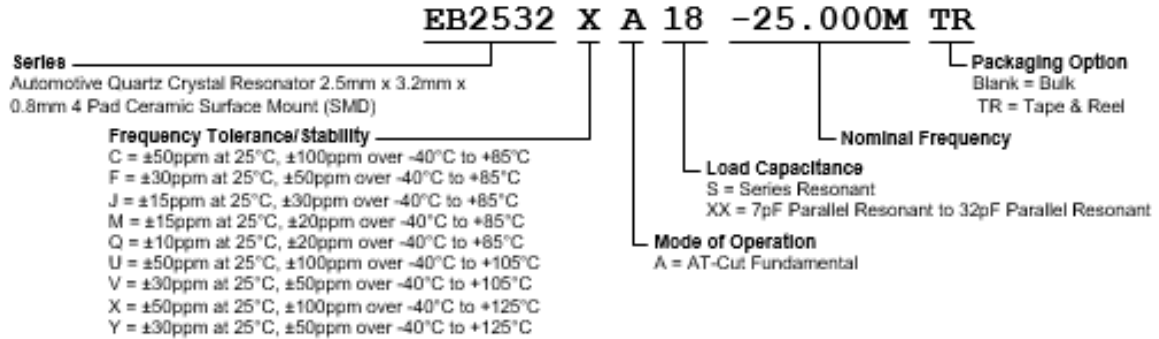

**ENVIRONMENTAL & MECHANICAL SPECIFICATIONS**

<b>ESD Susceptibility</b>	MIL-STD-883, Method 3015, Class 1, HBM: 1500V
<b>Fine Leak Test</b>	MIL-STD-883, Method 1014, Condition A
<b>Flammability</b>	UL94-V0
<b>Gross Leak Test</b>	MIL-STD-883, Method 1014, Condition C
<b>Mechanical Shock</b>	MIL-STD-883, Method 2002, Condition B
<b>Moisture Resistance</b>	MIL-STD-883, Method 1004
<b>Moisture Sensitivity</b>	J-STD-020, MSL 1
<b>Resistance to Soldering Heat</b>	MIL-STD-202, Method 210, Condition K
<b>Resistance to Solvents</b>	MIL-STD-202, Method 215
<b>Solderability</b>	MIL-STD-883, Method 2003
<b>Temperature Cycling</b>	MIL-STD-883, Method 1010, Condition B
<b>Vibration</b>	MIL-STD-883, Method 2007, Condition A

**MECHANICAL DIMENSIONS**

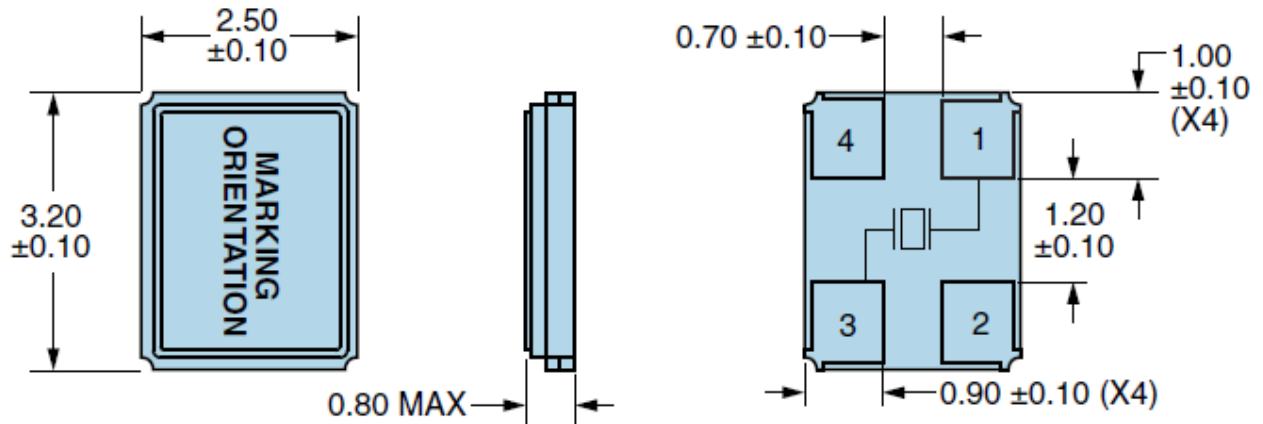

**Note:** Chamfer not shown.

**Seam Sealed**

**Terminal Plating Thickness:** Gold (0.3 to 1.0µm) over Nickel (1.27 to 8.89µm).

**SUGGESTED SOLDER PAD LAYOUT**

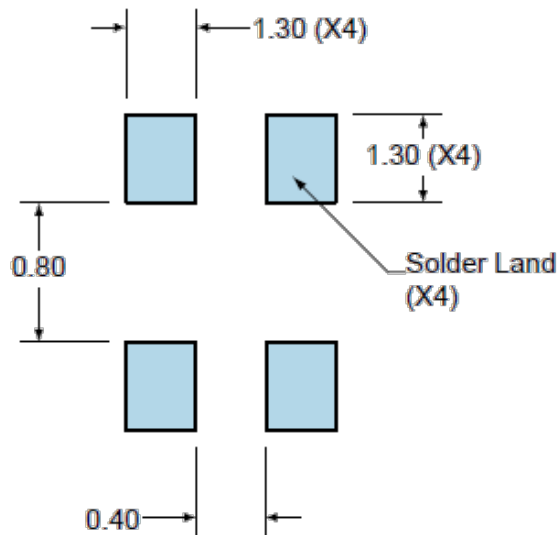

PIN	CONNECTION
1	Crystal
2	Cover/Ground
3	Crystal
4	Cover/Ground

All Tolerances are ±0.1

**All Dimensions in Millimeters**

**TAPE & REEL DIMENSIONS**

Quantity per Reel: 3,000 Units

All Dimensions in Millimeters

Compliant to EIA-481

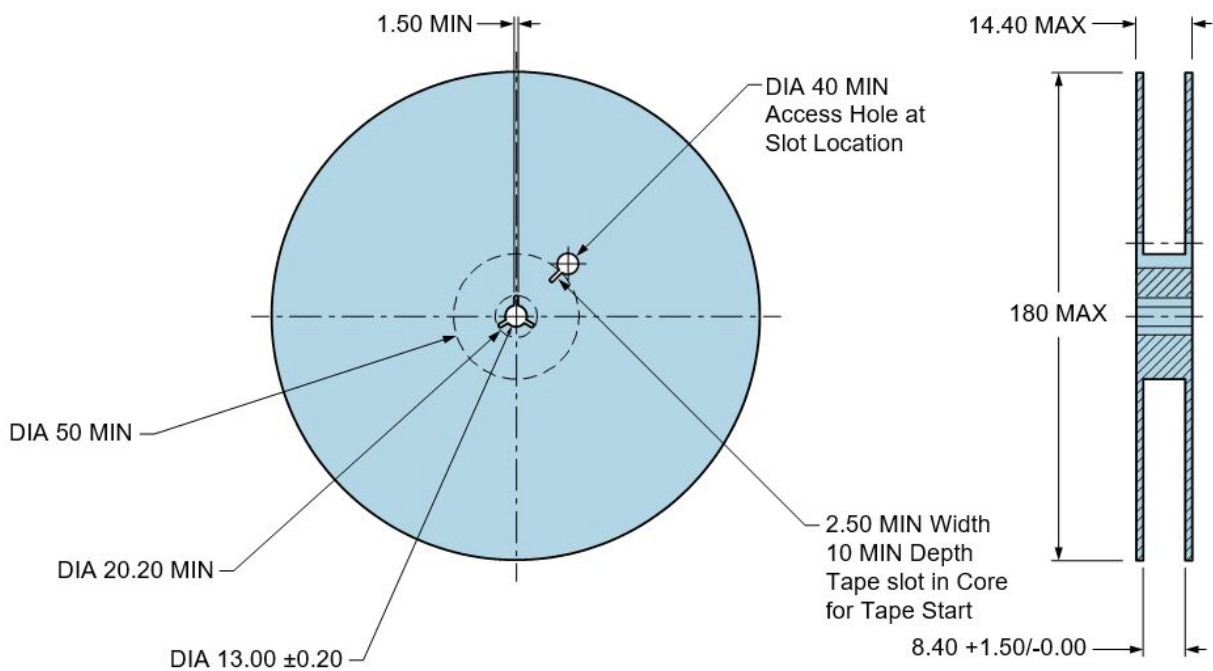
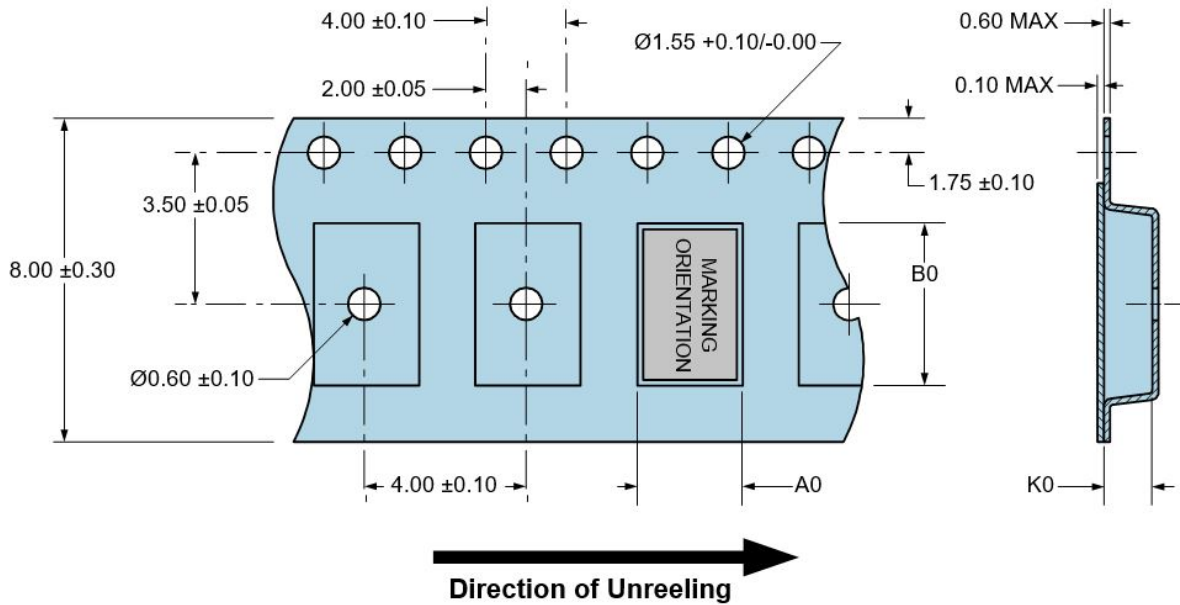

**RECOMMENDED SOLDER REFLOW METHOD**

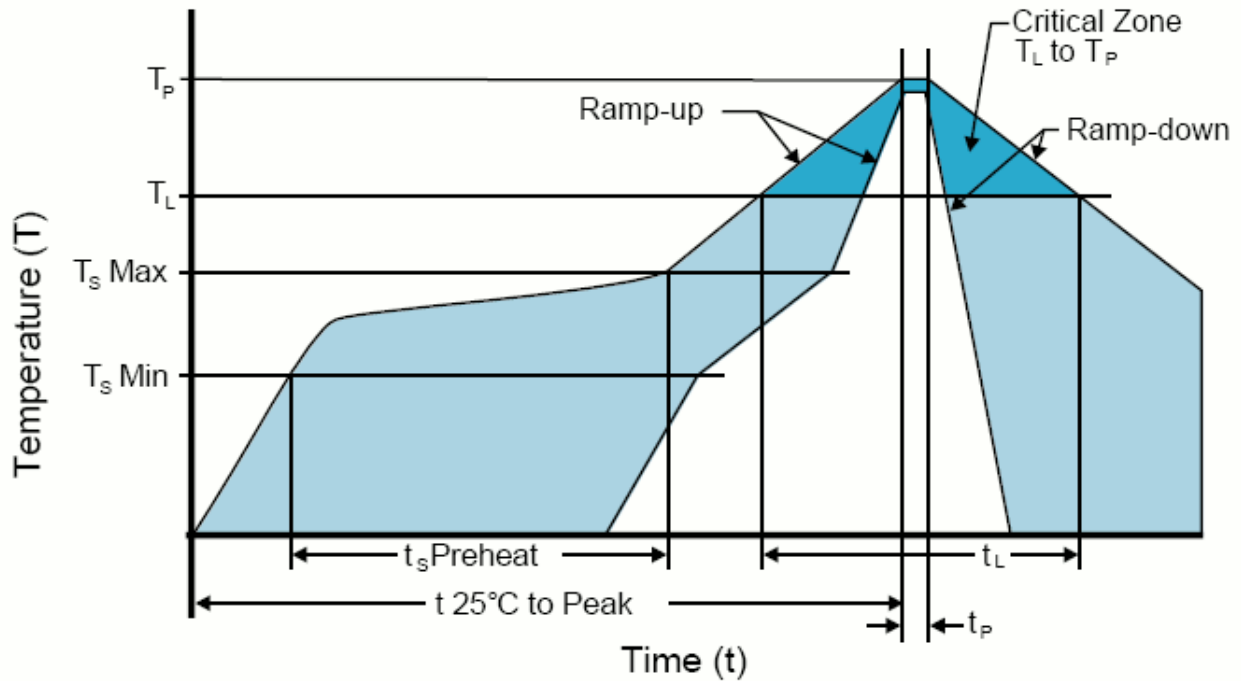

HIGH TEMPERATURE INFRARED/CONVECTION	
T <sub>S</sub> MAX to T <sub>L</sub> (Ramp-up Rate)	3°C/Second Maximum
<b>Preheat</b>	
- Temperature Minimum (T <sub>S</sub> MIN)	150°C
- Temperature Typical (T <sub>S</sub> TYP)	175°C
- Temperature Maximum(T <sub>S</sub> MAX)	200°C
- Time (t <sub>s</sub> MIN)	60 - 180 Seconds
Ramp-up Rate (T <sub>L</sub> to T <sub>P</sub> )	3°C/Second Maximum
<b>Time Maintained Above:</b>	
- Temperature (T <sub>L</sub> )	217°C
- Time (t <sub>L</sub> )	60 - 150 Seconds
Peak Temperature (T <sub>P</sub> )	260°C Maximum for 10 Seconds Maximum
Target Peak Temperature(T <sub>P</sub> Target)	250°C +0/-5°C
Time within 5°C of actual peak (t <sub>p</sub> )	20 - 40 Seconds
Ramp-down Rate	6°C/Second Maximum
Time 25°C to Peak Temperature (t)	8 Minutes Maximum
Moisture Sensitivity Level	Level 1
Additional Notes	Temperatures shown are applied to body of device.

**High Temperature Manual Soldering**

260°C Maximum for 5 Seconds Maximum, 2 times Maximum. (Temperatures shown are applied to body of device.)

RECOMMENDED SOLDER REFLOW METHOD

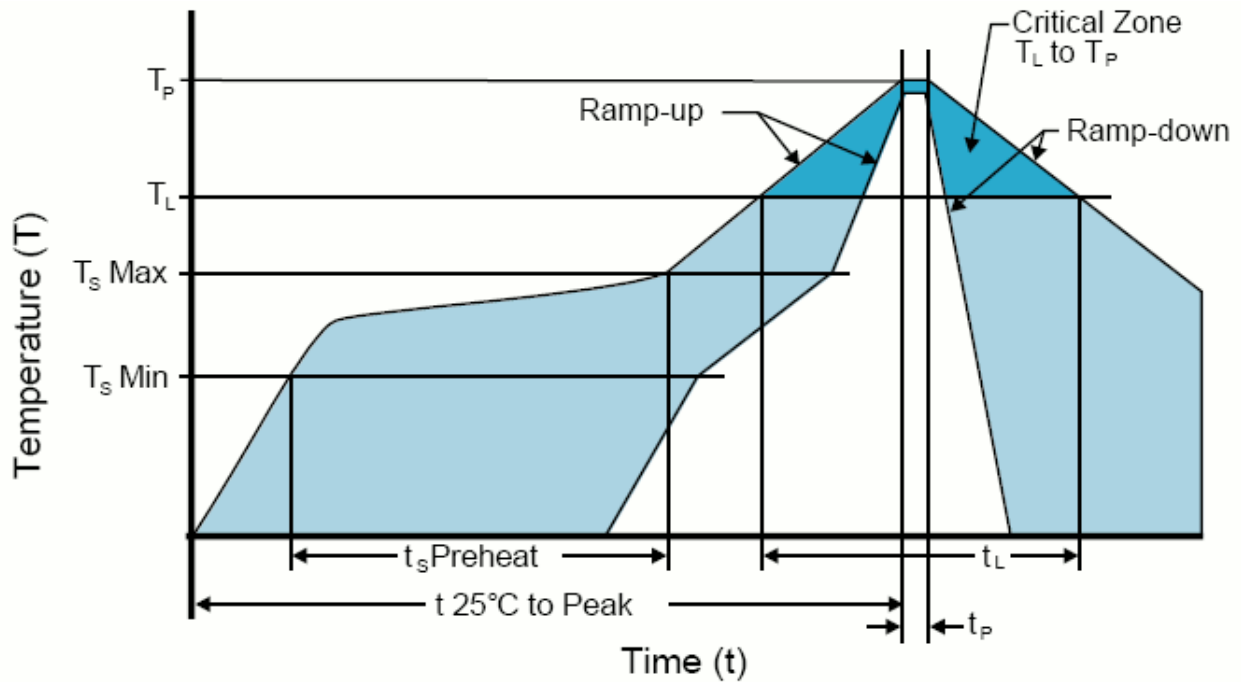

**LOW TEMPERATURE INFRARED/CONVECTION**

T <sub>S</sub> MAX to T <sub>L</sub> (Ramp-up Rate)	5°C/Second Maximum
<b>Preheat</b>	
- Temperature Minimum (T <sub>S</sub> MIN)	N/A
- Temperature Typical (T <sub>S</sub> TYP)	150°C
- Temperature Maximum(T <sub>S</sub> MAX)	N/A
- Time (t <sub>S</sub> MIN)	30 - 60 Seconds
Ramp-up Rate (T <sub>L</sub> to T <sub>P</sub> )	5°C/Second Maximum
<b>Time Maintained Above:</b>	
- Temperature (T <sub>L</sub> )	150°C
- Time (t <sub>L</sub> )	200 Seconds Maximum
Peak Temperature (T <sub>P</sub> )	245°C Maximum
Target Peak Temperature(T <sub>P</sub> Target)	245°C Maximum 2 Times/230°C Maximum 1Time
Time within 5°C of actual peak (t <sub>P</sub> )	10 Seconds Maximum 2 Times / 80 Seconds Maximum 1 Time
Ramp-down Rate	5°C/Second Maximum
Time 25°C to Peak Temperature (t)	N/A
Moisture Sensitivity Level	Level 1
Additional Notes	Temperatures shown are applied to body of device.

**Low Temperature Manual Soldering**

185°C Maximum for 10 Seconds Maximum, 2 times Maximum. (Temperatures shown are applied to body of device.)