

REGULATORY COMPLIANCE

 <p>Lead Free COMPLIANT</p>	 <p>EU RoHS 2011/65 + 2015/863 COMPLIANT</p>	 <p>China RoHS COMPLIANT</p>	 <p>REACH SVHC COMPLIANT</p>	 <p>DRC CONFLICT FREE</p>
--	--	--	--	---

ITEM DESCRIPTION

Automotive Grade Quartz Crystal Resonator 1.6mm x 2.0mm x 0.55mm 4 Pad Ceramic Surface Mount (SMD)

ELECTRICAL SPECIFICATIONS

Nominal Frequency	16MHz to 54MHz
Frequency Tolerance/Stability	±50ppm at 25°C, ±100ppm over -40°C to +85°C ±30ppm at 25°C, ±50ppm over -40°C to +85°C ±15ppm at 25°C, ±30ppm over -40°C to +85°C ±15ppm at 25°C, ±20ppm over -40°C to +85°C ±10ppm at 25°C, ±20ppm over -40°C to +85°C ±50ppm at 25°C, ±100ppm over -40°C to +105°C ±30ppm at 25°C, ±50ppm over -40°C to +105°C ±50ppm at 25°C, ±100ppm over -40°C to +125°C ±30ppm at 25°C, ±50ppm over -40°C to +125°C
Aging at 25°C	±3ppm/year Maximum
Load Capacitance	Series Resonant, 8pF Parallel Resonant to 32pF Parallel Resonant
Shunt Capacitance	3pF Maximum
Equivalent Series Resistance	200 Ohms Maximum over Nominal Frequency of 16MHz to 19.999999MHz 120 Ohms Maximum over Nominal Frequency of 20MHz to 24.999999MHz 100 Ohms Maximum over Nominal Frequency of 25MHz to 39.999999MHz 60 Ohms Maximum over Nominal Frequency of 40MHz to 54MHz
Mode of Operation	AT-Cut Fundamental
Drive Level	100µWatts Maximum
Spurious Response	Measured from Fo to Fo +5000ppm -3dB Minimum
Storage Temperature Range	-50°C to +150°C
Insulation Resistance	Measured at 100Vdc 500 Megaohms Minimum

PART NUMBERING GUIDE

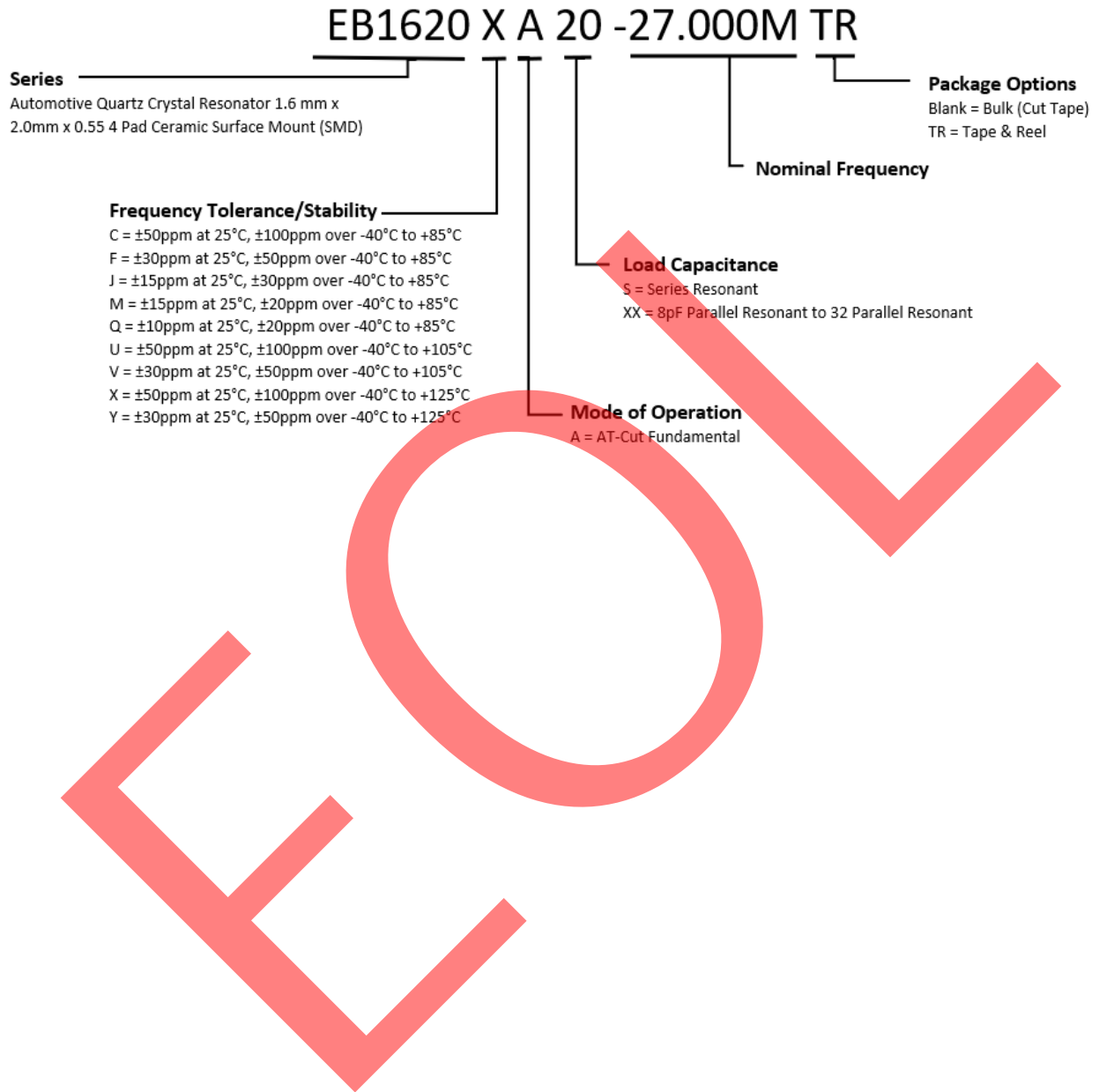

EB1620 Series

MECHANICAL DIMENSIONS

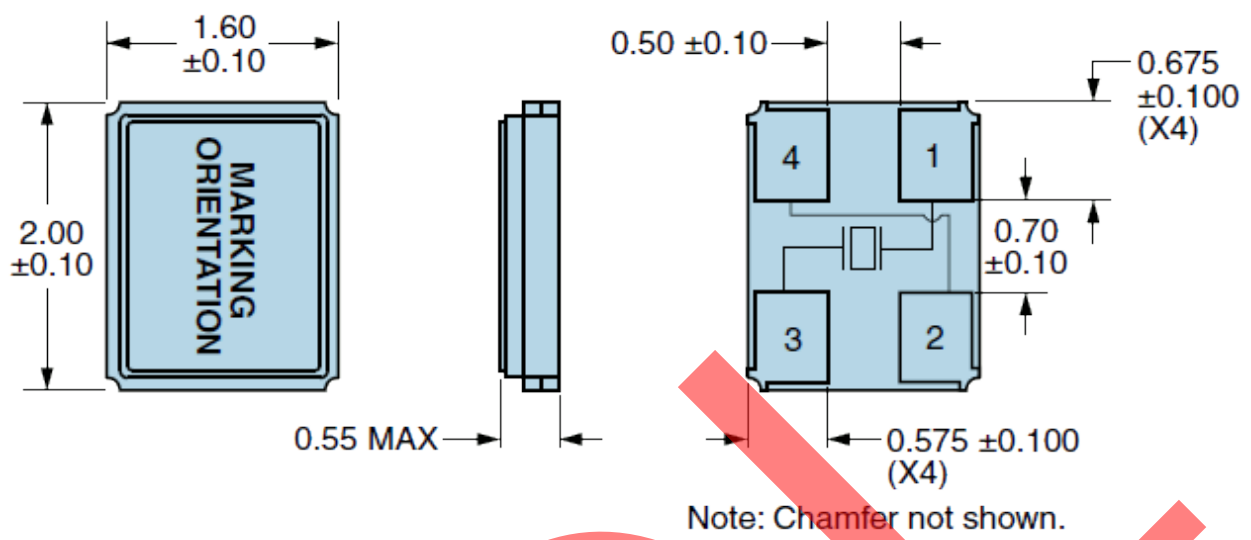

Seam Sealed

Terminal Plating Thickness: Gold (0.3 to 1.0µm) over Nickel (1.27 to 8.89µm).

SUGGESTED SOLDER PAD LAYOUT

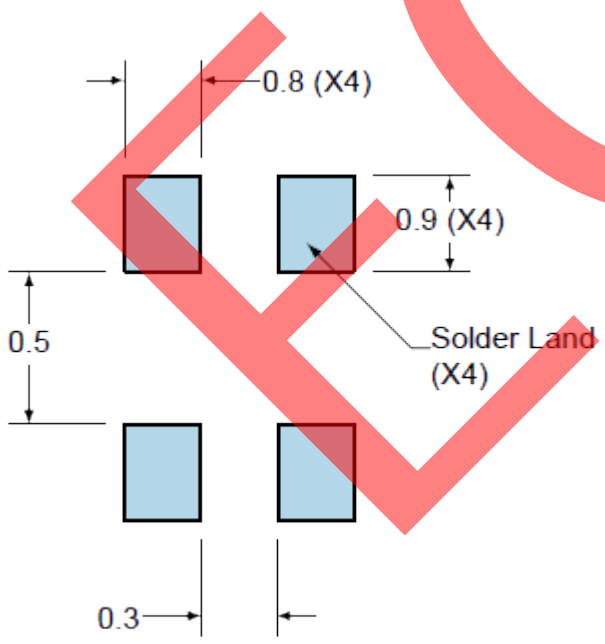

PIN	CONNECTION
1	Crystal
2	Cover/Ground
3	Crystal
4	Cover/Ground

All Tolerances are ±0.1

All Dimensions in Millimeters

TAPE & REEL DIMENSIONS

Quantity per Reel: 3,000 Units

All Dimensions in Millimeters

Compliant to EIA-481

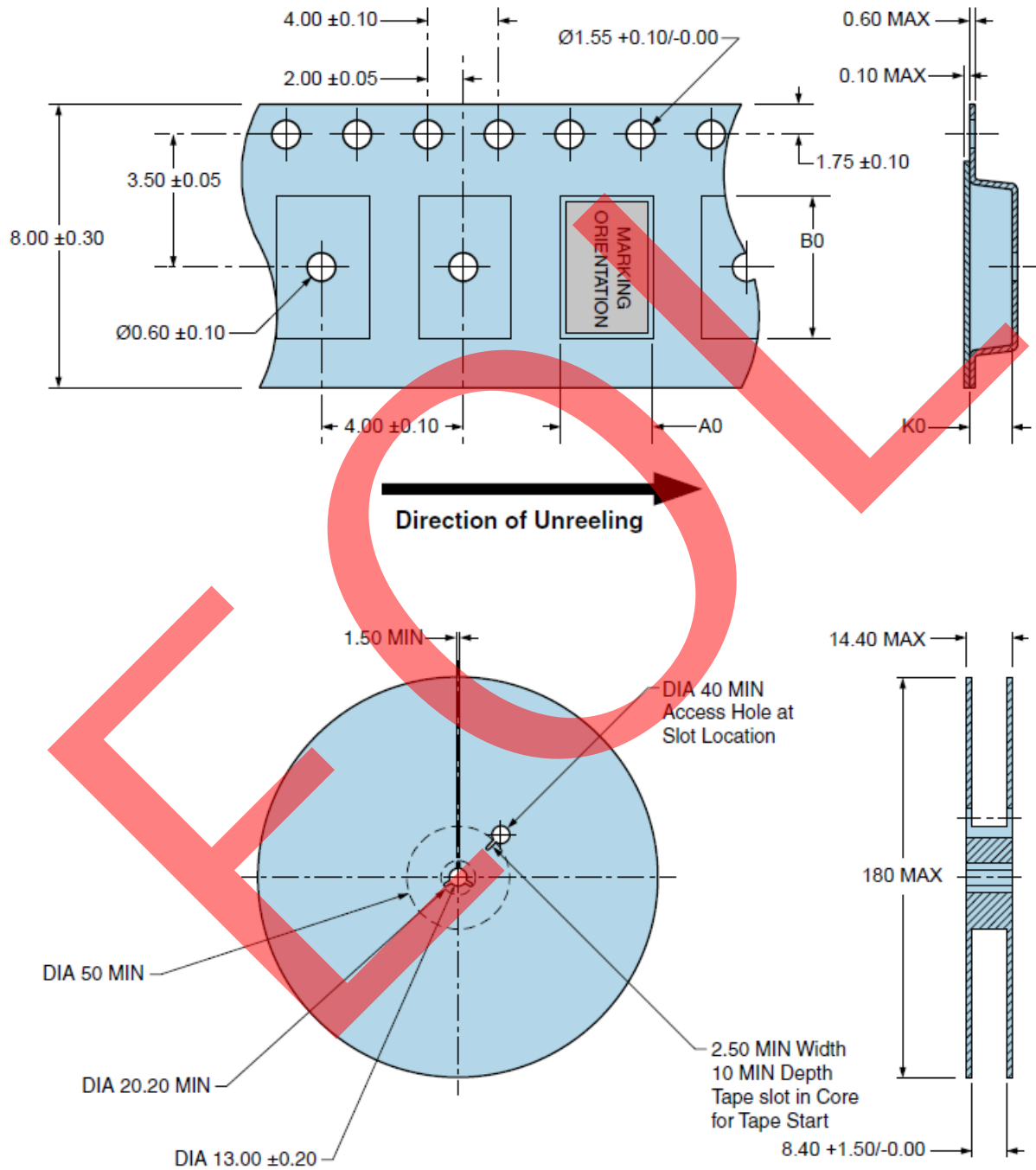

RECOMMENDED SOLDER REFLOW METHOD

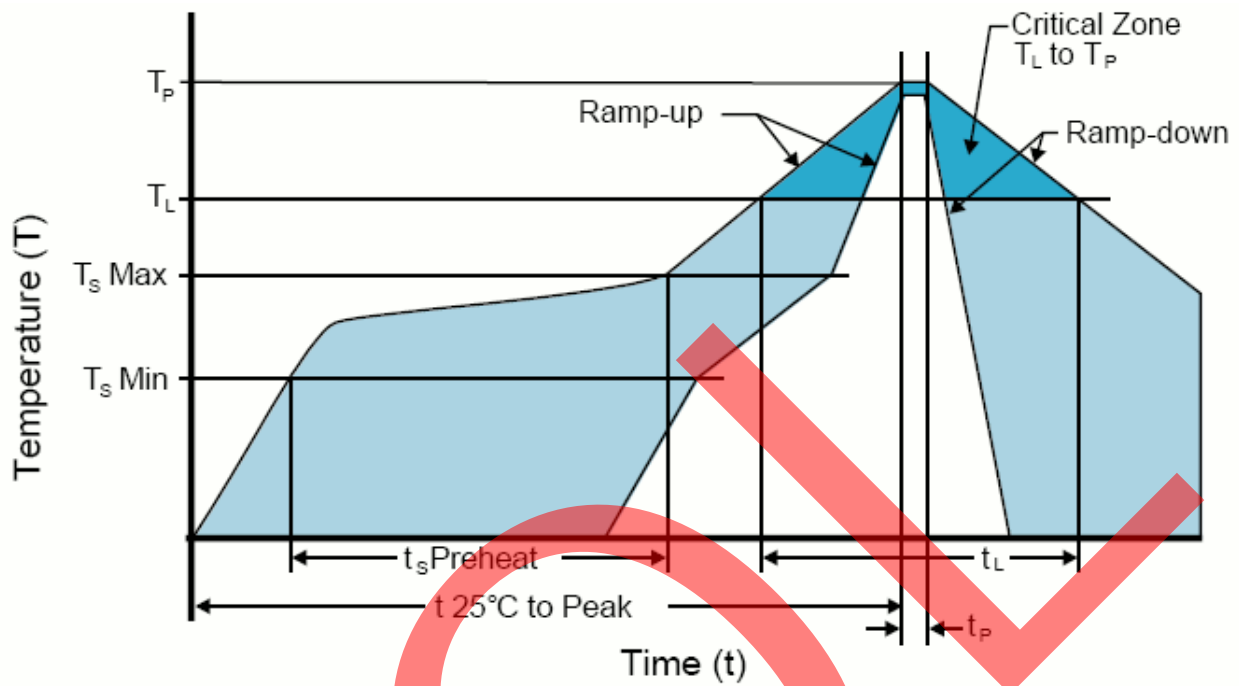

HIGH TEMPERATURE INFRARED/CONVECTION

T_s MAX to T_L (Ramp-up Rate)	3°C/Second Maximum
Preheat	
- Temperature Minimum (T_s MIN)	150°C
- Temperature Typical (T_s TYP)	175°C
- Temperature Maximum (T_s MAX)	200°C
- Time (t_s)	60 - 180 Seconds
Ramp-up Rate (T_L to T_P)	3°C/Second Maximum
Time Maintained Above:	
- Temperature (T_L)	217°C
- Time (t_L)	60 - 150 Seconds
Peak Temperature (T_P)	260°C Maximum for 10 Seconds Maximum
Target Peak Temperature (T_P Target)	250°C +0/-5°C
Time within 5°C of actual peak (t_P)	20 - 40 Seconds
Ramp-down Rate	6°C/Second Maximum
Time 25°C to Peak Temperature (t)	8 Minutes Maximum
Moisture Sensitivity Level	Level 1
Additional Notes	Temperatures shown are applied to body of device.

High Temperature Manual Soldering

260°C Maximum for 5 Seconds Maximum, 2 times Maximum. (Temperatures shown are applied to body of device.)

RECOMMENDED SOLDER REFLOW METHOD

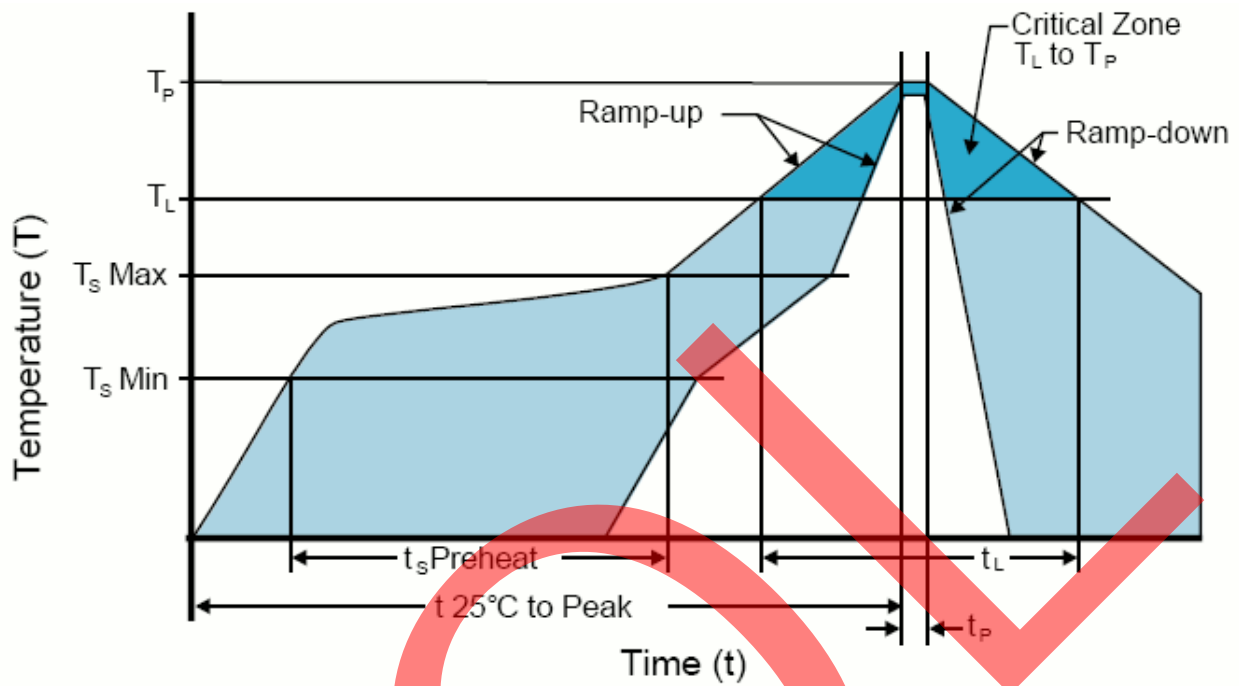

LOW TEMPERATURE INFRARED/CONVECTION

$T_s \text{ MAX to } T_L$ (Ramp-up Rate)	5°C/Second Maximum
Preheat	
- Temperature Minimum ($T_s \text{ MIN}$)	N/A
- Temperature Typical ($T_s \text{ TYP}$)	150°C
- Temperature Maximum ($T_s \text{ MAX}$)	N/A
- Time (t_s)	30 - 60 Seconds
Ramp-up Rate (T_L to T_P)	5°C/Second Maximum
Time Maintained Above:	
- Temperature (T_L)	150°C
- Time (t_L)	200 Seconds Maximum
Peak Temperature (T_P)	245°C Maximum
Target Peak Temperature ($T_P \text{ Target}$)	245°C Maximum 2 Times / 230°C Maximum 1 Time
Time within 5°C of actual peak (t_P)	10 Seconds Maximum 2 Times / 80 Seconds Maximum 1 Time
Ramp-down Rate	5°C/Second Maximum
Time 25°C to Peak Temperature (t)	N/A
Moisture Sensitivity Level	Level 1
Additional Notes	Temperatures shown are applied to body of device.

Low Temperature Manual Soldering

185°C Maximum for 10 Seconds Maximum, 2 times Maximum. (Temperatures shown are applied to body of device.)