

0.3 mm Pitch Back-lock FPC Connectors

FF12 Series

DDK Ltd.

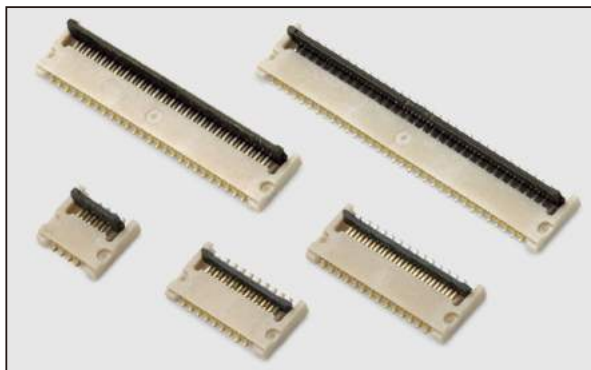

OUTLINE

The FF12 series back-lock LIF connector allows for design flexibility by incorporating both an upper contact and a lower contact to interface with a 0.15mm thick FPC at a 0.3mm pitch. The low profile connector has a 0.9mm height, making it one of the smallest board mounted FPC ZIF connectors on the market.

APPLICATIONS

Mobile Phone, Digital Camera, MP3 Player, Portable PC, PDA and other Portable Device

FEATURE

- This connector utilize both an upper and lower contact to allow for all FPC insertion directions.
- DDK's original cam-type back-lock system provides reliable operation and ensures retention from inadvertent upward pulling of the FPC.
- The FF12 connector has a low height of 0.9mm.
- Back-lock mechanism ensures retention from inadvertent from upward pulling of the FPC.
- These ZIF connectors are delivered with the lock lever opened for maximum production efficiency.
- This connector is available in contact counts ranging from 6 pins to 65 pins.
- Contacts utilize a nickel barrier to prevent solder wicking.
- The housing and lock lever are made of heat-resistant resin making possible lead-free reflow soldering.
- FF12 ZIF connectors are delivered in a tape and reel package for automated machine processes.

SPECIFICATIONS

Rated Voltage	50V AC(r.m.s.)
Rated Current	0.2A / Contact
Dielectric Withstand Voltage	200V AC (r.m.s.) / 1 minute
Insulation Resistance	50 M.Ω(min.) at 250V DC
Contact Resistance	50m Ω (max.)

MATERIAL//FINISH



Contact	Copper Alloy / Au(Flash) over Ni Plating
Housing	LCP Resin (UL94V-0) / Ivory
Lock Lever	PPS Resin (UL94V-0) / Black

Caution: Regarding the handling this connector, please refer to the attached instruction manual.

▶ Short Lock Type

FF12- A-R11AL-

Number of Contact

Lock Lever Type
A : Short Lock

Material
No Digit : Non-Halogen Free
3H : Halogen Free

Part Number	Number of Contact	A	B	C	D
FF12-8A-R11AL-□	8	4.60	2.80	2.10	2.70
FF12-10A-R11AL-□	10	5.20	3.40	2.70	3.30
FF12-12A-R11AL-□	12	5.80	4.00	3.30	3.90
FF12-13A-R11AL-□	13	6.10	4.30	3.60	4.20
FF12-17A-R11AL-□	17	7.30	5.50	4.80	5.40
FF12-18A-R11AL-□	18	7.60	5.80	5.10	5.70
FF12-21A-R11AL-□	21	8.50	6.70	6.00	6.60
FF12-22A-R11AL-□	22	8.80	7.00	6.30	6.90
FF12-27A-R11AL-□	27	10.30	8.50	7.80	8.40
FF12-29A-R11AL-□	29	10.90	9.10	8.40	9.00
FF12-32A-R11AL-□	32	11.80	10.00	9.30	9.90
FF12-34A-R11AL-□	34	12.40	10.60	9.90	10.50
FF12-39A-R11AL-□	39	13.90	12.10	11.40	12.00

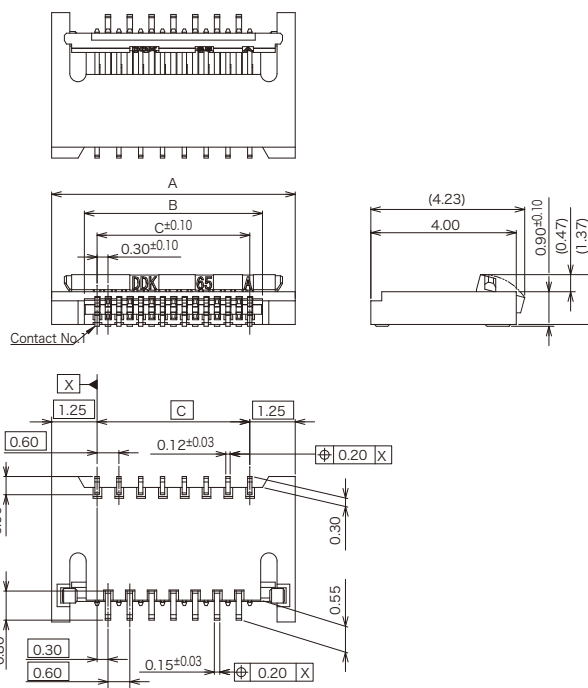

▶ Long Lock Type

FF12- A-R11BL-

Number of Contact

Lock Lever Type
B : Long Lock

Material
No Digit : Non-Halogen Free
3H : Halogen Free

Part Number	Number of Contact	A	B	C	D
FF12-6A-R11BL-□	6	4.00	2.20	1.50	2.10
FF12-8A-R11BL-□	8	4.60	2.80	2.10	2.70
FF12-10A-R11BL-□	10	5.20	3.40	2.70	3.30
FF12-12A-R11BL-□	12	5.80	4.00	3.30	3.90
FF12-13A-R11BL-□	13	6.10	4.30	3.60	4.20
FF12-17A-R11BL-□	17	7.30	5.50	4.80	5.40
FF12-18A-R11BL-□	18	7.60	5.80	5.10	5.70
FF12-21A-R11BL-□	21	8.50	6.70	6.00	6.60
FF12-22A-R11BL-□	22	8.80	7.00	6.30	6.90
FF12-23A-R11BL-□	23	9.10	7.30	6.60	7.20
FF12-25A-R11BL-□	25	9.70	7.90	7.20	7.80
FF12-26A-R11BL-□	26	10.00	8.20	7.50	8.10
FF12-27A-R11BL-□	27	10.30	8.50	7.80	8.40
FF12-29A-R11BL-□	29	10.90	9.10	8.40	9.00
FF12-31A-R11BL-□	31	11.50	9.70	9.00	9.60
FF12-32A-R11BL-□	32	11.80	10.00	9.30	9.90
FF12-37A-R11BL-□	37	13.30	11.50	10.80	11.40
FF12-39A-R11BL-□	39	13.90	12.10	11.40	12.00
FF12-40A-R11BL-□	40	14.20	12.40	11.70	12.30
FF12-45A-R11BL-□	45	15.70	13.90	13.20	13.80
FF12-51A-R11BL-□	51	17.50	15.70	15.00	15.60
FF12-55A-R11BL-□	55	18.70	16.90	16.20	16.80
FF12-60A-R11BL-□	60	20.20	18.40	17.70	18.30
FF12-65A-R11BL-□	65	21.70	19.90	19.20	19.80

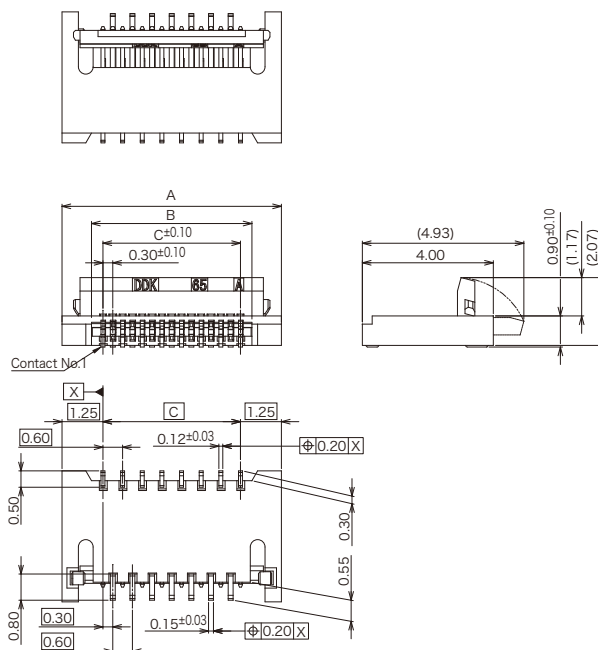

© Specifications and/or dimensions in this catalog are subject to change without notice.
Please verify the latest specifications with our drawings.

▶ FF12 Series Mounting Dimensions

■ PCB Mounting Dimensions

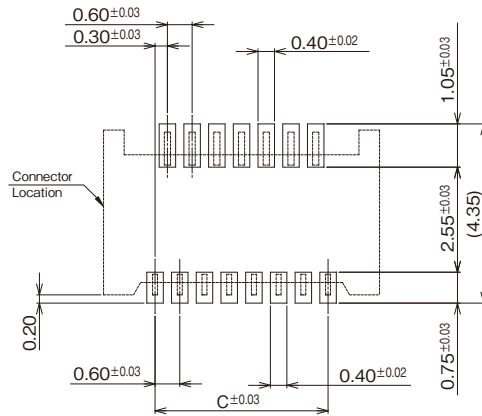

※ Regarding dimension C, please refer to the table on page 2.

■ Recommended FPC Dimensions

For Odd Number of Contact

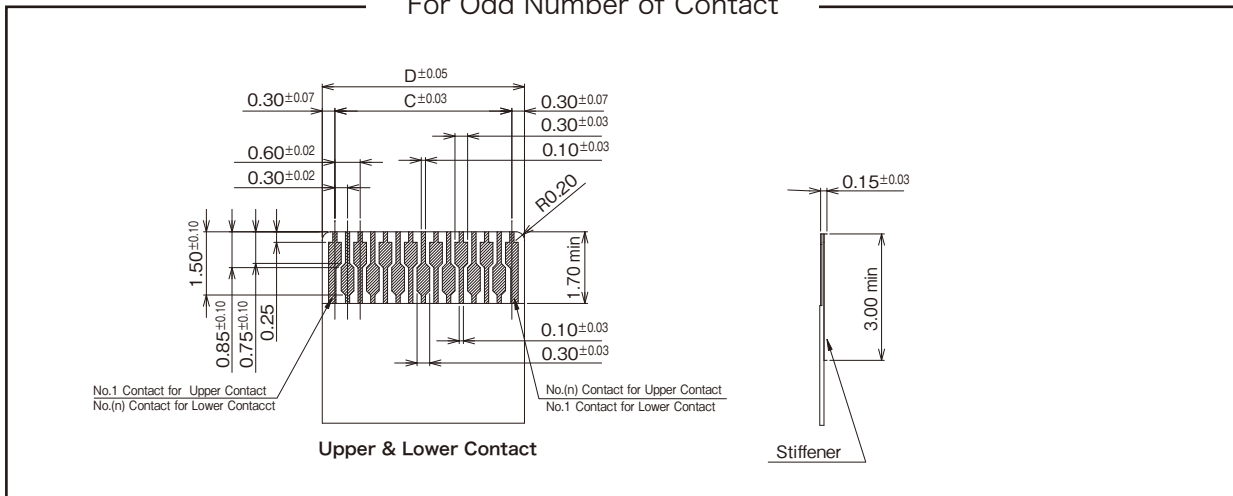

For Even Number of Contact

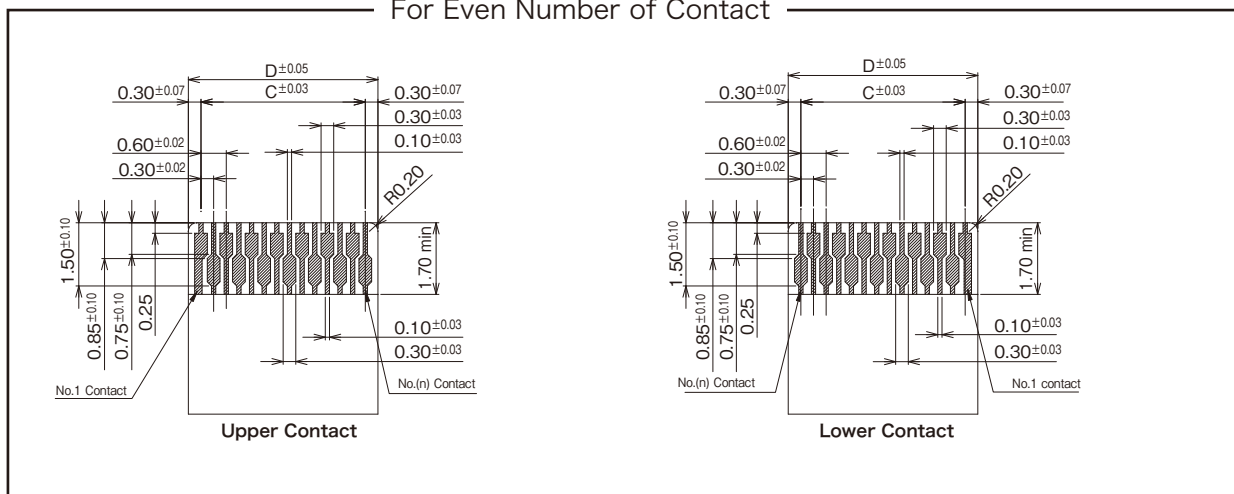

※ Regarding dimensions C and D, please refer to the table on page 2.

© Specifications and/or dimensions in this catalog are subject to change without notice.
Please verify the latest specifications with our drawings.

Package Specifications

Reel Dimensions

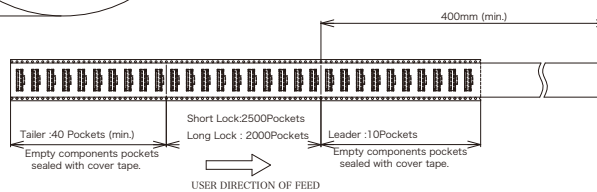
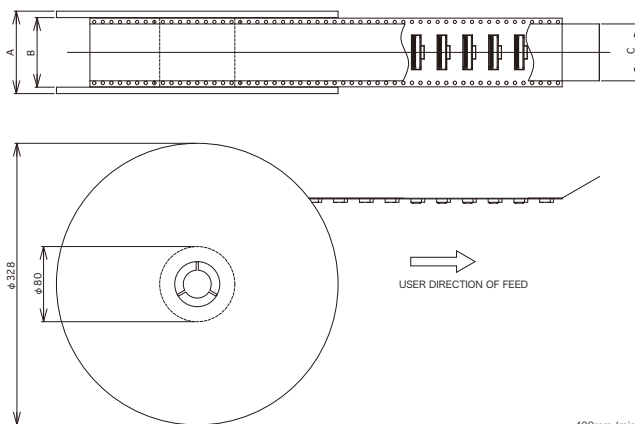
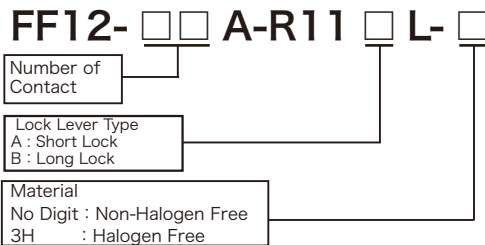

Emboss Tape Dimensions

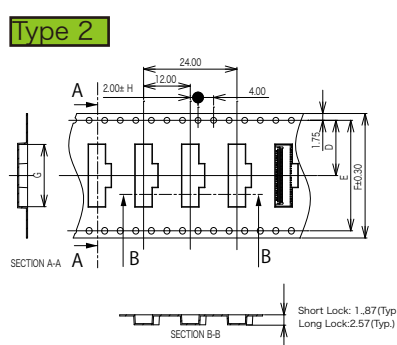
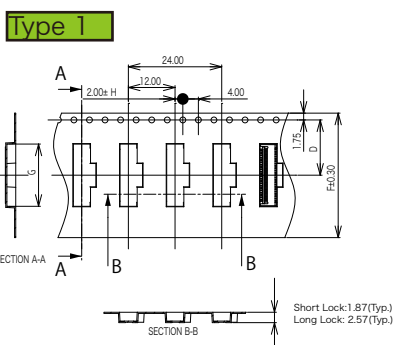

Part Number	Number of Contact	A	B	C	D	E	F	G	H	Emboss Type	Package Quantity
FF12-8A-R11AL-□	8							4.9		Type 1	2500pcs. / Reel
FF12-10A-R11AL-□	10							5.5			
FF12-12A-R11AL-□	12							6.1			
FF12-13A-R11AL-□	13							6.4			
FF12-17A-R11AL-□	17							7.6			
FF12-18A-R11AL-□	18	30.4	24.4	21.5	11.5	-	24.0	7.9			
FF12-21A-R11AL-□	21							8.8	0.1		
FF12-22A-R11AL-□	22							9.1			
FF12-27A-R11AL-□	27							10.6			
FF12-29A-R11AL-□	29							11.2			
FF12-32A-R11AL-□	32							12.1			
FF12-34A-R11AL-□	34	38.4	32.4	26.5	14.2	28.4	32.0	12.7	Type 2		
FF12-39A-R11AL-□	39							14.2			

Part Number	Number of Contact	A	B	C	D	E	F	G	H	Emboss Type	Package Quantity
FF12-6A-R11BL-□	6							4.3		Type 1	2000pcs. / Reel
FF12-8A-R11BL-□	8							4.9			
FF12-10A-R11BL-□	10							5.5			
FF12-12A-R11BL-□	12							6.1			
FF12-13A-R11BL-□	13							6.4			
FF12-17A-R11BL-□	17							7.6			
FF12-18A-R11BL-□	18	30.4	24.4	21.5	11.5	-	24.0	7.9			
FF12-21A-R11BL-□	21							8.8			
FF12-22A-R11BL-□	22							9.1			
FF12-23A-R11BL-□	23							9.4			
FF12-25A-R11BL-□	25							10.0	0.1		
FF12-26A-R11BL-□	26							10.3			
FF12-27A-R11BL-□	27							10.6			
FF12-29A-R11BL-□	29							11.2			
FF12-31A-R11BL-□	31							11.8			
FF12-32A-R11BL-□	32							12.1			
FF12-37A-R11BL-□	37							13.6			
FF12-39A-R11BL-□	39	38.4	32.4	26.5	14.2	28.4	32.0	14.2			
FF12-40A-R11BL-□	40							14.5			
FF12-45A-R11BL-□	45							16.0			
FF12-51A-R11BL-□	51							17.8			
FF12-55A-R11BL-□	55							19.0			
FF12-60A-R11BL-□	60	50.4	44.4	38.5	20.2	40.4	44.0	20.5	0.15		
FF12-65A-R11BL-□	65							22.0			
										Type 2	

© Specifications and/or dimensions in this catalog are subject to change without notice.
Please verify the latest specifications with our drawings.

▶ Recommended Reflow Temperature Profiles

■ for Lead Solder Paste

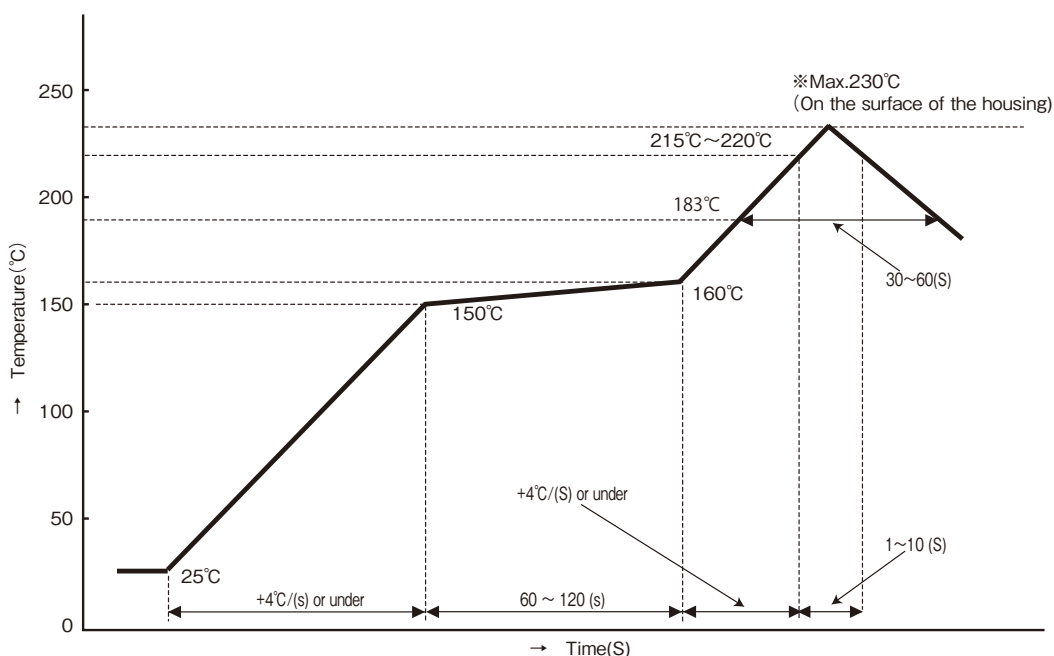

Temperature measurement part : Terminal lead part. But the temperature on the surface of housing is 230°C(max.)
 Metal Mask : 0.1~0.12mm
 Recommended Solder Paste: Senju Metal Industry Co.,Ltd. Sparkle Paste P/N: OZ63-221CM5-42-10
 Reflow Cycle : 2 times

■ for Lead Free Solder Paste

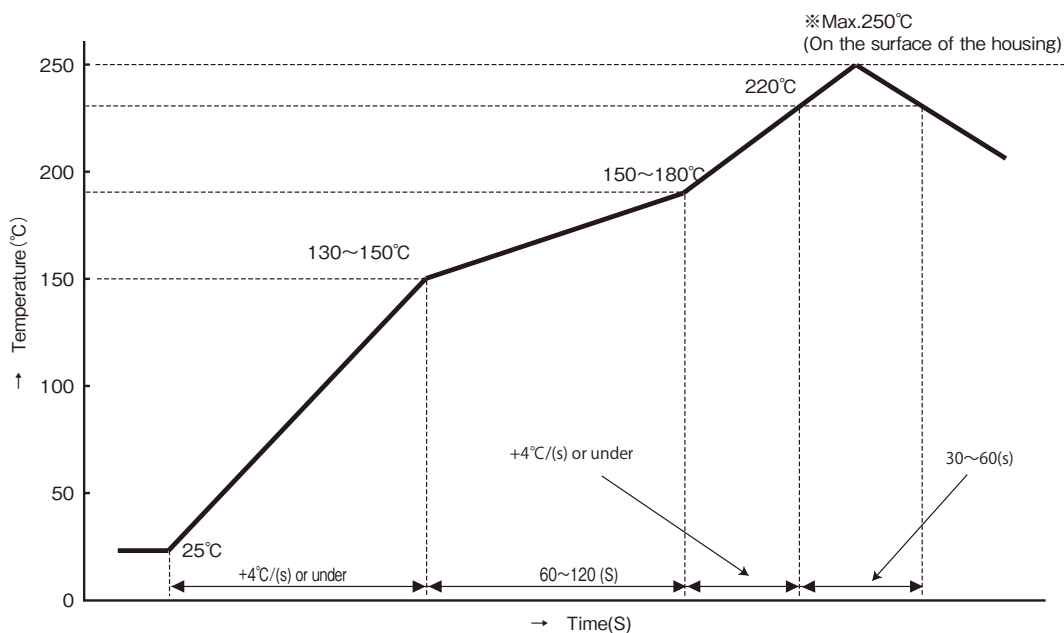

Temperature measurement part : Terminal lead part. But the temperature on the surface of husing is 250°C(max.)
 Metal Mask : 0.1~0.12mm
 Recommended Solder Paste : Senju Metal Industry Co.,Ltd. Eco Solder Paste P/N:M705-GRN360-K2-V
 Reflow Cycle : 2 times

Caution

This reflow temperature profile is for your reference. It might be changed the temperature condition depend on the solder paste, volume and flax.

© Specifications and/or dimensions in this catalog are subject to change without notice.
 Please verify the latest specifications with our drawings.