



element14

---

**EN** - For pricing and availability in your local country please visit one of the below links:

**DE** - Informationen zu Preisen und Verfügbarkeit in Ihrem Land erhalten Sie über die unten aufgeführten Links:

**FR** - Pour connaître les tarifs et la disponibilité dans votre pays, cliquez sur l'un des liens suivants:

[880175](#)

**EN**

This Datasheet is presented by  
the manufacturer

**DE**

Dieses Datenblatt wird vom  
Hersteller bereitgestellt

**FR**

Cette fiche technique est  
présentée par le fabricant

## TR SERIES DUAL POLE MASTER DISCONNECT SWITCH

500A • DPST • IP67/IP69k • Integrated Lock-Out Tag-Out



880175

880175-0002

880175-0001

### Description

Cuts all battery power from vehicle electrical systems with applications needing switching of two circuits, or both positive and negative. 500A continuous current rating for each of the two circuits (using 2 x 4/0 input and 2 x 4/0 output cables). Can be used to switch two vehicle voltage circuits simultaneously (24V and 12V). Disconnect a battery or multiple batteries, in either the positive or the negative line.

### Features and Benefits

- Ingress protection to IP67 and IP69K means that the switch can be mounted in exposed locations on the vehicle.
- Drop-in replacement for competitive Master Disconnect Switches, with higher vibration and shock capabilities.
- Direct lockout/tagout capability in On or Off position, with padlock or hasp.



### Specifications Overview

<b>Max Operating Voltage:</b>	48V DC
<b>Max Continuous Current:</b>	500A per circuit, with 2 x 4/0 input and 2 x 4/0 output cables 350A per circuit, with 1 x 4/0 input and 1 x 4/0 output cables
<b>Operating Temp:</b>	-50° to 85°C, DC-Rated to 105°C
<b>Ingress Rating:</b>	IP67/IP69K

### Web Resources

Download technical resources at:  
[littelfuse.com/TR](http://littelfuse.com/TR)

### Ordering Information

PART NUMBER	DESCRIPTION
880175	Master Disconnect Switch
880175-0001	Master Disconnect Switch TR Dual Red Knob
880175-0002	Master Disconnect SwitchTR Dual Yellow Knob
880302	Master Disconnect Switch TR 2 Pole (CB)

Datasheet Replaces Hotfeed Number D-647

## TR SERIES DUAL POLE MASTER DISCONNECT SWITCH

### Specifications

<b>Max Operating Voltage</b>	48V DC
<b>Max Continuous Current</b>	500A per circuit, with 2 x 4/0 input and 2 x 4/0 output cables 350A per circuit, with 1 x 4/0 input and 1 x 4/0 output cables
<b>Cranking Rating (30sec)</b>	2250A per circuit, with 2 x 4/0 input and 2 x 4/0 output cables 1750A per circuit, with 1 x 4/0 input and 1 x 4/0 output cables
<b>Inrush Rating (1 sec)</b>	3000A per circuit with 2 x 4/0 + 1 x 2 AWG
<b>Terminal Stud Size</b>	M12 x 25mm
<b>Recommended Terminal Torque</b>	20 N-m (30 Nm Max)
<b>Temperature Range</b>	-50° to 85°C, DC-Rated to 105°C
<b>Humidity</b>	0 – 95% RH
<b>Shock</b>	30 G
<b>Vibration</b>	8 G
<b>Ingress Protection</b>	IP67 & IP69K
<b>Recommended Mounting Torque</b>	15 N-m (20Nm Max)

Note: ambient temperature can reach 105°C with appropriate current de-rating. Stud terminals must never exceed 125°C under any condition.

### Dimensions

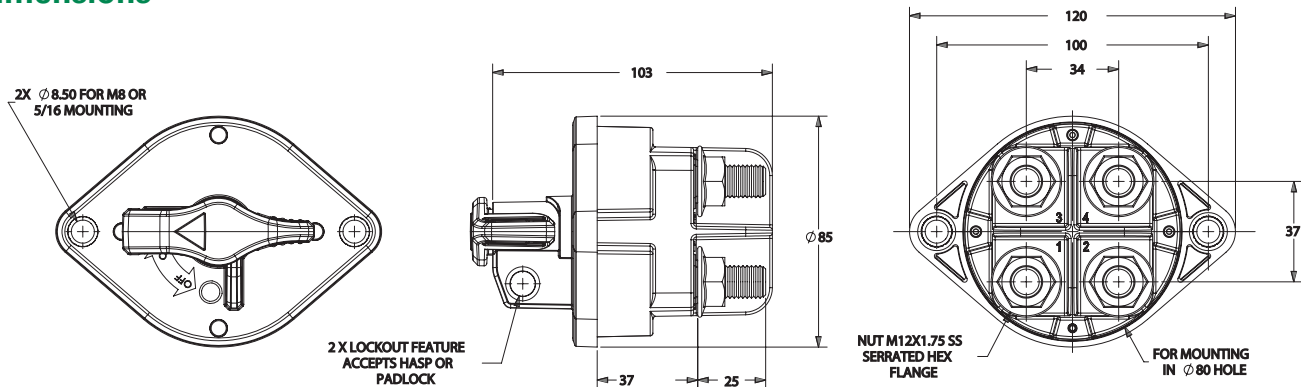

### Configurations

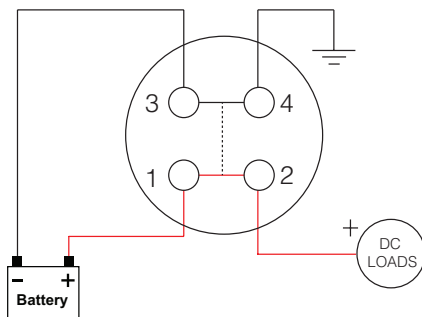

**Master Battery Disconnect Dual Pole**  
Switching One Battery, Positive and Negative  
(shown in ON state)

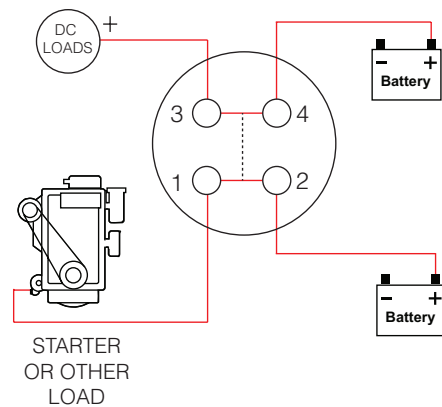

**Master Battery Disconnect Dual Pole**  
Switching Two Batteries  
(shown in ON state)



Visit [Littelfuse.com](http://Littelfuse.com) for the most up-to-date product information. Littelfuse products are designed for specific applications and should not be used for any purpose (including, without limitation, automotive applications) not expressly set forth in applicable Littelfuse product documentation. Warranties granted by Littelfuse shall be deemed void for products used for any purpose not expressly set forth in applicable Littelfuse product documentation. Littelfuse shall not be liable for any claims or damages arising out of products used in applications not expressly intended by Littelfuse as set forth in applicable Littelfuse product documentation.



element14

---

**EN** - For pricing and availability in your local country please visit one of the below links:

**DE** - Informationen zu Preisen und Verfügbarkeit in Ihrem Land erhalten Sie über die unten aufgeführten Links:

**FR** - Pour connaître les tarifs et la disponibilité dans votre pays, cliquez sur l'un des liens suivants:

[880175](#)

**EN**

This Datasheet is presented by  
the manufacturer

**DE**

Dieses Datenblatt wird vom  
Hersteller bereitgestellt

**FR**

Cette fiche technique est  
présentée par le fabricant