

PART NUMBER CREATOR

6 S T D 0 9 S A M 9 9 B 3 0 X

Product Line

- 6 = Shell brass tin plated with die-cast frame
- 4* = Shell brass tin plated with plastic frame or without frame
- 8* = Shell stainless steel with or without die-cast frame
- 9* = Shell stainless steel with plastic frame
- * on request

Variations

- STD = D-SUBMINIATURE, Standard
- HDD = D-SUBMINIATURE, High Density

Position for STD

- 09 = 9 pos.
- 15 = 15 pos.
- 25 = 25 pos.
- 37 = 37 pos.
- 50 = 50 pos.

Position for HDD

- 15 = 15 pos.
- 26 = 26 pos.
- 44 = 44 pos.
- 62 = 62 pos.
- 78 = 78 pos.

Contact type

- P = Plug connector
- S = Socket connector
- A = Adapter

Quality class for contacts

- A = Quality class 3 = 50 mating cycles
- B = Quality class 2 = 200 mating cycles
- C = Quality class 1 = 500 mating cycles

Termination

- M = Solder cup
- R = Solder pin, straight
- T = Solder pin, angled, .189"/4.80 mm
- U = Solder pin, angled, .276"/7.00 mm
- Z = Solder pin, angled, .465"/11.8 mm
- Y = Solder pin, angled, .220"/5.60 mm (high density design only)
- A = Adapter

Capacitance

- 99 = Without filter for STD and HDD

Mounting style

- | | |
|--|---|
| A1 = Riveted for wire assembly shell without sealing frame | E2 = Threaded rear spacer with PCB clip, PCB 1,60 mm |
| B2 = M3 threaded insert | S1 = Metal bracket, M3 threaded insert |
| B3 = 4-40 UNC threaded insert | S2 = Metal bracket, 4-40 UNC threaded insert |
| B4 = M3 front spacer | S3 = Metal bracket, M3 threaded insert and PCB clip |
| B5 = 4-40 UNC front spacer | S4 = Metal bracket, 4-40 UNC threaded insert and PCB clip |
| B7 = 4-40 UNC front spacer and rear mounting stud | R1 = Metal bracket, M3 threaded insert |
| B8 = M3 threaded lock | R2 = Metal bracket, 4-40 UNC threaded insert |
| B9 = 4-40 UNC front spacer | R3 = Metal bracket, M3 threaded insert and PCB clip |
| E1 = M3 threaded rear spacer with PCB clip .063"/1.60 mm | R4 = Metal bracket, 4-40 UNC threaded insert and PCB clip |

- OX = Standard

TECHNICAL DATA

Materials	D-Subminiature, Standard 9, 15, 25, 37 and 50 position	D-Subminiature, High Density 15, 26, 44, 62 and 78 position
Insulator	Polyester GF UL94 V-0	
Contacts	CU alloy	
Contact plating	Gold plated over nickel	
Shell	Brass tin plated (Standard) Stainless steel on request	
Mechanical and electrical characteristics		
Test voltage U eff/NN	1000 V	
Working voltage	125 V ≈ 60 V ≈ depending on isolation coordination (refer to DIN VDE 0110/IEC 664-1)	
Current rating	7.5 A (UL) / 5 A (CSA,VDE)	3 A (UL,VDE) / 2.5 A (CSA)
Contact resistance	max. 10 mΩ prior to stressing, Δ R max. 10 mΩ after stressing per DIN 41652, Part 2	
Insulation resistance	≥ 5 GΩ	
Clearance and creepage distance	contact – contact ≥ .004" / 1.0 mm contact – earth ≥ .047" / 1.2 mm	≥ .024" / 0.6 mm
Operating temperature	– 25 °C to + 105 °C	
Mating and unmating forces	9 pos. ≤ 30 N 15 pos. ≤ 50 N 25 pos. ≤ 83 N 37 pos. ≤ 123 N 50 pos. ≤ 167 N	15 pos. ≤ 50 N 26 pos. ≤ 84 N 44 pos. ≤ 120 N 62 pos. ≤ 70 N 78 pos. ≤ 200 N
Quality class	A = Quality class 3 = 50 mating cycles B = Quality class 2 = 200 mating cycles C = Quality class 1 = 500 mating cycles	

Technical alterations are subject to change without notice.

IP-CODE FIGURE DEFINITIONS

1. Code figure	Definition	Remark
0	Not protected	
1	Protected against access to hazardous parts by the back of the hand. Protected against fixed foreign objects $\varnothing \geq 1.969'' / 50$ mm.	
2	Protected against access to hazardous parts with a finger. Protected against fixed foreign objects $\varnothing \geq .492'' / 12.5$ mm.	
3	Protected against access to hazardous parts with a tool. Protected against fixed foreign objects $\varnothing \geq .098'' / 2.5$ mm.	
4	Protected against access to hazardous parts with a wire. Protected against fixed foreign objects $\varnothing \geq .039'' / 1$ mm.	
5	Protected against access to hazardous parts with a wire. Dust protected.	Ingress of dust is not completely blocked. But dust may not penetrate to the extent that satisfactory operation of the device or safety is impaired.
6	Protected against access to hazardous parts with a wire. Dustproof. No ingress of dust.	

2. Code figure	Definition	Remark
0	Not protected	
1	Protected against dropper.	
2	Protected against dropper when the shell is tipped as much as 15°.	
3	Protected against spray water	Up to 60° of either side of the vertical, such spray water shall have no harmful effects.
4	Protected against splash water	On the shell from all directions, no harmful effects shall be incurred.
5	Protected against jets of water.	
6	Protected against strong jets of water.	
7	Protected against the effects of temporary submersion in water.	Water may not ingress in a volume that would cause harmful effects when the shell is submerged in water for 30 min at a depth of 1 m.
8	Protected against the effects of continuous submersion in water.	Water may not ingress in a volume that would cause harmful effects when the shell is continuously submerged in water under conditions agreed between manufacturer and user. However, these conditions must be more stringent than those described under code figure 7.
9k	Protected against water from high-pressure or steam cleaning.	

Explanation to spray water protected (IP) systems and their environment.

This system, described in IEC 60529, was developed to represent standard values for respective protection:

- a) Contact with, and ingress of, fixed foreign objects
- b) The ingress of liquids to which the inside is to be exposed.

The first digit describes the level of protection for life, contacting objects and the intrusion of foreign bodies. The second digit describes the level of protection against the ingress of liquids. The larger the first and second digits are, the greater afforded protection is, e.g. IP55 must also meet the requirements of all lower protection levels, such as IP22, IP23, IP34 and IP54.

MATING CONDITIONS

Float mount tolerance guide

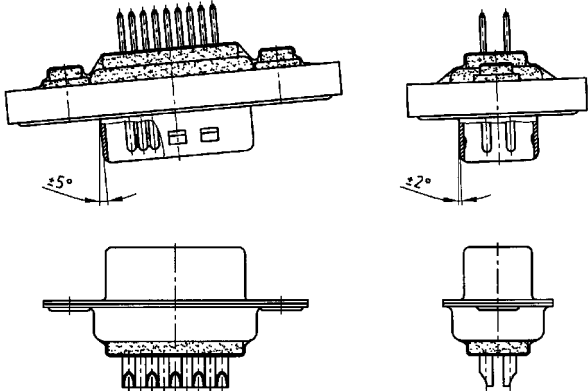

Rigid mount tolerance guide

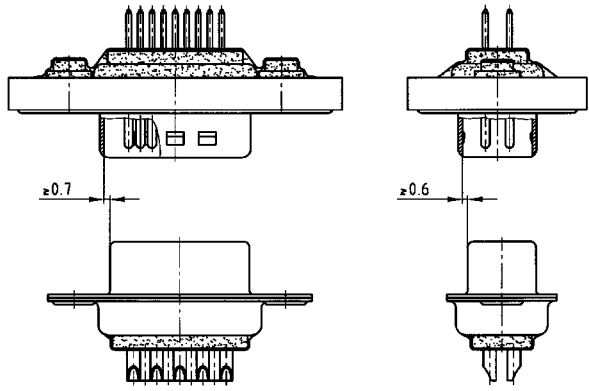

Rigid mount vertical to tolerance guide

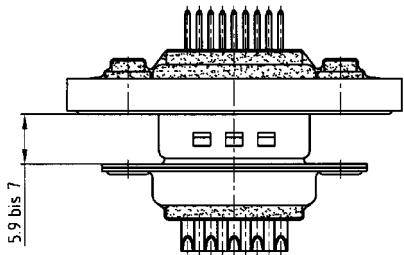

PANEL CUT-OUT

Rear panel mounting IP67 D-SUB Connectors

Front panel mounting IP67 D-SUB Connectors

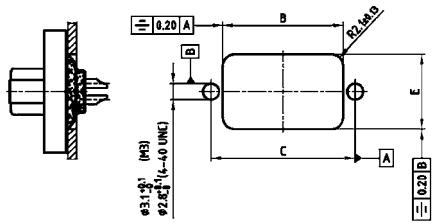
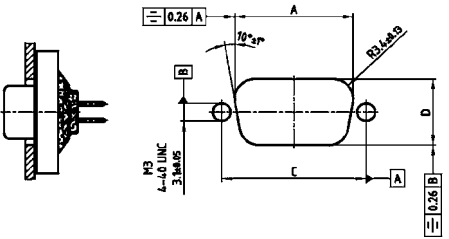

Shell size	A ± 0.1	B ± 0.1	C ± 0.1	D ± 0.1	E ± 0.1
1	20.50	20.90	25.00	11.40	13.00
2	28.80	29.20	33.30	11.40	13.00
3	42.50	42.90	47.04	11.40	13.00
4	59.10	59.40	63.50	11.40	13.00
5	56.30	57.00	61.10	14.10	15.80

PANEL MOUNTING

FRONT PANEL MOUNTING

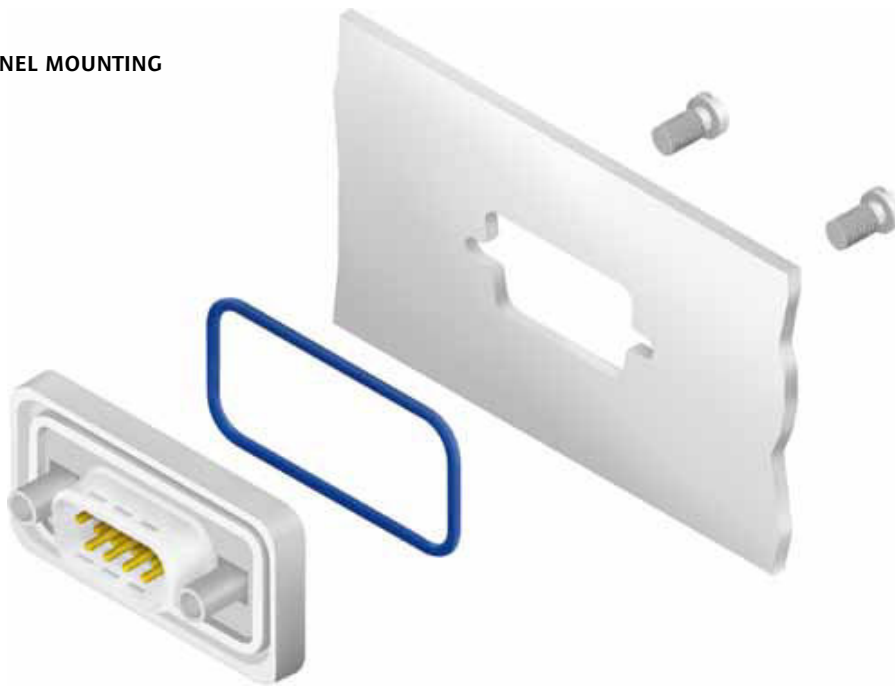

REAR PANEL MOUNTING



The hex bolts illustrated here (4-40 UNC or M3 threads) are included in the delivery complement of every connector with a sealing frame. The length of this spacer has been selected to accommodate a panel thickness of .063"/1.6 mm such that it does not extend beyond the plug-in height. Furthermore, the hex bolts outside threads are shorter than standard hex bolts. Material: stainless steel.

SOLDER PROFILE

Connector Type	Preheating		Solder terminal dipping parameters	
	max. Temperature	Duration	max. Solder bath Temperature	max. Terminal Immersion Time
Filter D-SUB	100°C	30s	260°C	5s
Combo D-SUB Filter	120°C	120s	260°C	5s
Filter D-SUB Water Resistant	100°C	30s	240°C	5s
Combo D-SUB Water Resistant	120°C	120s	240°C	5s
D-SUB Water Resistant	120°C	120s	240°C	5s
D-SUB Solid Body Type Water Resistant	150°C	180s	265°C	8s
RJ45 Modular Jack Filtered	150°C	180s	265°C	8s
Filter Plates	150°C	180s	265°C	8s

Recommended wave-solder parameters for CONEC connectors.

PCB LAYOUT, D-SUB HIGH DENSITY

Solder pin, angled, .220" / 5.6 mm – Socket connector

15 POS.

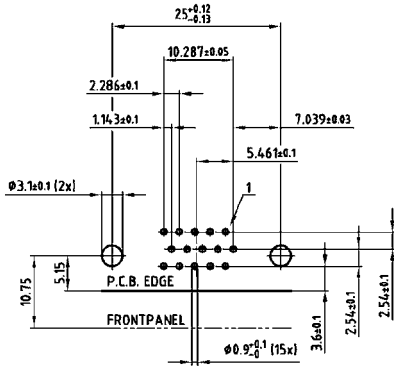

62 POS.

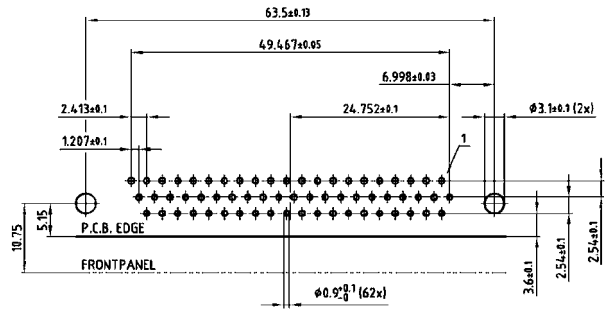

26 POS.

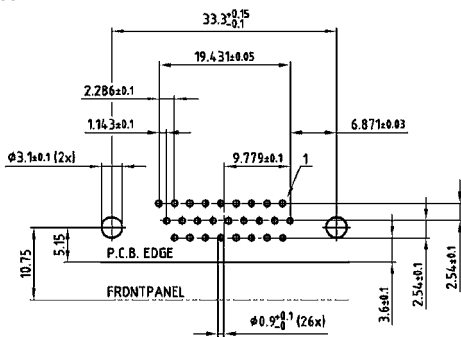

78 POS.

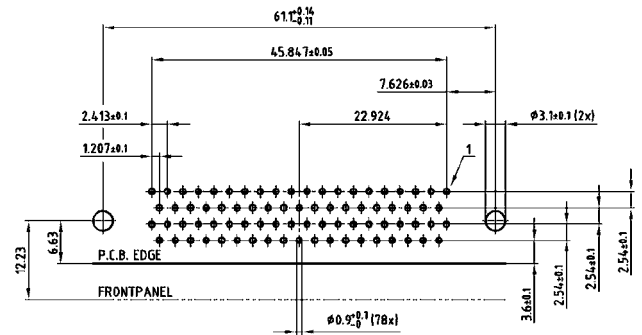

44 POS.

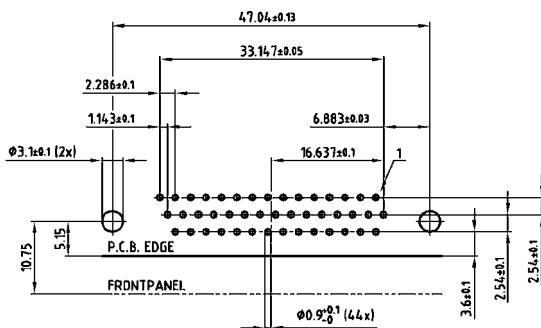

PCB layout Kat1kGVA (View: component side)

PCB LAYOUT, D-SUB HIGH DENSITY

Solder pin, angled, .220" / 5.6 mm – Plug connector

15 POS.

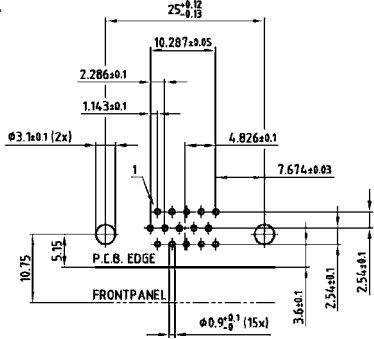

62 POS.

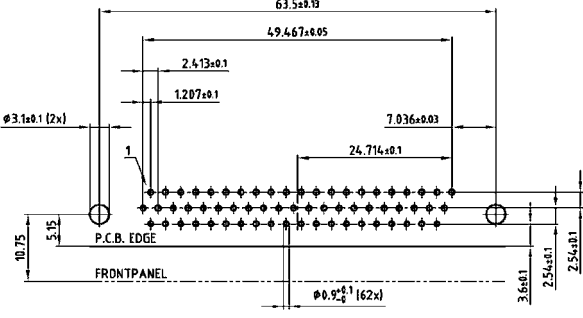

26 POS.

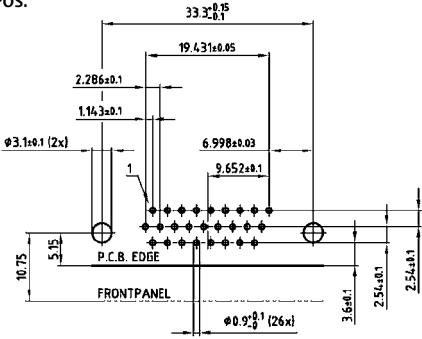

78 POS.

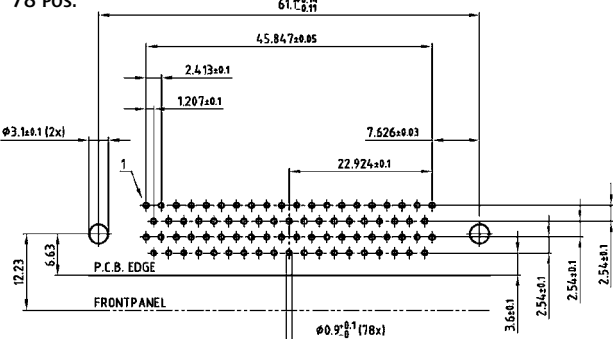

44 POS.

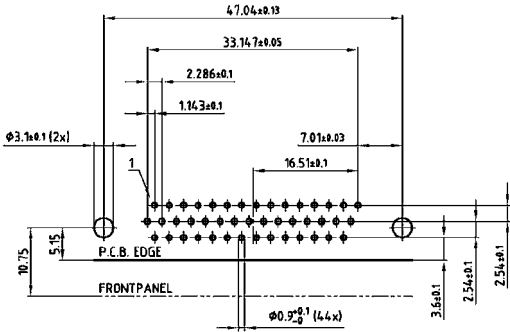

PCB layout Kat1kGWA (View: component side)