

| | |
|------------------------|---|
| DRAWING NUMBER: | 25-2550-1-XXXX |
| PRODUCT GROUP: | BANANA PLUGS, JACKS AND PHONE TIPS |
| SUB-GROUP: | INSULATED BANANA PLUGS |
| DESCRIPTION: | INSULATED STANDARD DUAL BANANA PLUGS/JACKS W/SET SCREWS |

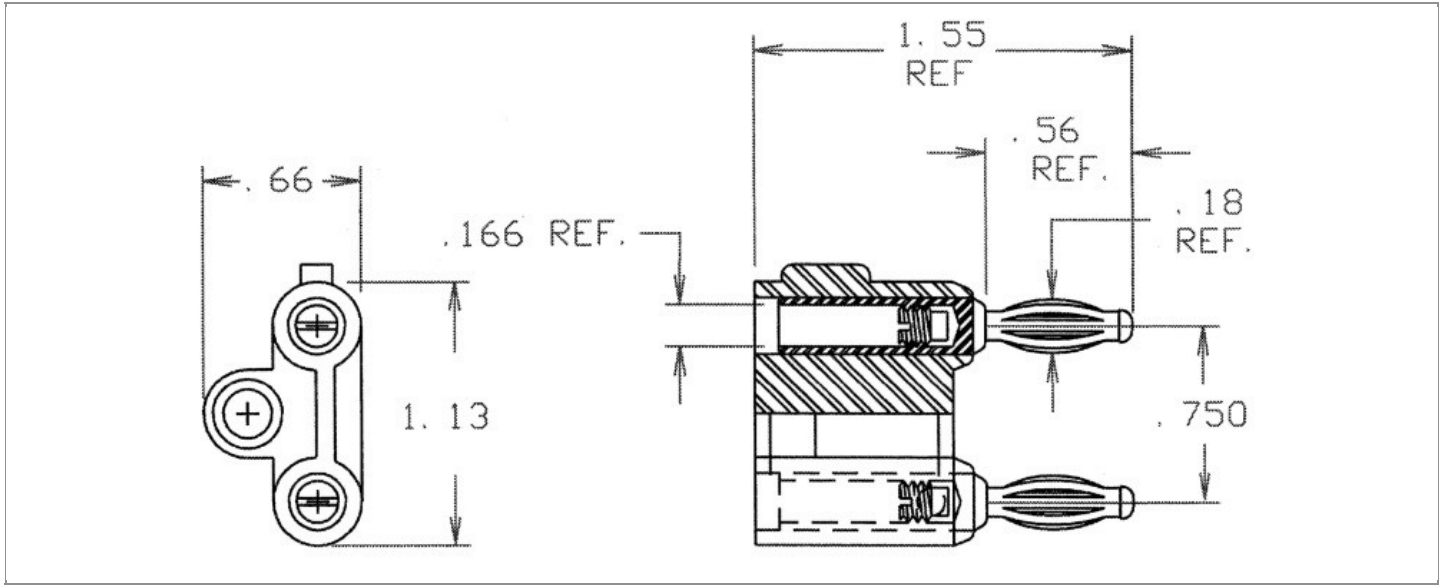

| ACCEPTS PIN / PLUG / JACK SIZE | OVERALL LENGTH | CABLE / WIRE SIZE |
|-----------------------------------|----------------|---------------------------|
| STANDARD BANANA JACK | 1.550" | ACCEPTS UP TO 10 AWG WIRE |

PART NO. STRUCTURE:

| | | | | | | |
|-------------|---|-----------|---|--------|--|------------------|
| 25-2550 | - | 1 | - | XX | | XX |
| PART SERIES | | DIMENSION | | FINISH | | INSULATION COLOR |

MATERIAL OPTIONS:

25-2550-1-XXXX

| COMPONENT | MATERIAL | MATERIAL AND SPECIFICATION |
|---------------|------------------|--|
| BODY | BRASS | BRASS PER ASTM B16, ALLOY C36000, 1/2 HARD |
| SPRING (CAGE) | BERYLLIUM COPPER | BERYLLIUM COPPER PER ASTM B194, ALLOY C17200 |
| INSULATION* | ABS | ABS PER ASTM D4673 |
| TERMINAL | N/A | N/A |
| SET SCREW | STEEL | STEEL |
| STUD | N/A | N/A |
| JACK SPRING | N/A | N/A |

*For Insulation color, please see INSULATION COLOR OPTIONS on Page 3

FINISH - PLATING OPTIONS:

25-2550-1-XXXX

| FINISH CODE | COMPONENT | FINISH | FINISH AND SPECIFICATION |
|-------------|---------------|--------------------|--|
| 01 | BODY | SILVER | 0.000100"MIN. SILVER PER ASTM B700, TYPE 2, GRADE D WITH A NON-CHROMATE PRESERVATIVE TREATMENT |
| | SPRING (CAGE) | SILVER | 0.000300"MIN. SILVER PER ASTM B700, TYPE 2, GRADE D WITH A NON-CHROMATE PRESERVATIVE TREATMENT |
| | TERMINAL | N/A | N/A |
| | SET SCREW | ZINC | ZINC |
| | STUD | N/A | N/A |
| | JACK SPRING | N/A | N/A |
| 02 | BODY | NICKEL | 0.000100"MIN. NICKEL PER SAE-AMS-QQ-N-290 |
| | SPRING (CAGE) | NICKEL | 0.000200"MIN. NICKEL PER SAE-AMS-QQ-N-290 |
| | TERMINAL | N/A | N/A |
| | SET SCREW | ZINC | ZINC |
| | STUD | N/A | N/A |
| | JACK SPRING | N/A | N/A |
| 03 | BODY | GOLD | GOLD FLASH PER ASTM B488, TYPE II, CODE C |
| | SPRING (CAGE) | GOLD | 0.000010"MIN. GOLD PER ASTM B488, TYPE II, CODE C |
| | TERMINAL | N/A | N/A |
| | SET SCREW | ZINC | ZINC |
| | STUD | N/A | N/A |
| | JACK SPRING | N/A | N/A |
| 044 | BODY | BRIGHT ELECTRO-TIN | 0.000200"MIN. BRIGHT ELECTRO-TIN PER ASTM B545 |
| | SPRING (CAGE) | BRIGHT ELECTRO-TIN | 0.000200"MIN. BRIGHT ELECTRO-TIN PER ASTM B545 |
| | TERMINAL | N/A | N/A |
| | SET SCREW | ZINC | ZINC |
| | STUD | N/A | N/A |
| | JACK SPRING | N/A | N/A |

INSULATION COLOR OPTIONS:

25-2550-1-XX **XX**

| INSULATION COLOR | BLACK | BROWN | RED | ORANGE | YELLOW | GREEN | BLUE | VIOLET | GRAY | WHITE |
|------------------|-------|-------|-----|--------|--------|-------|------|--------|------|-------|
| COLOR CODE NO. | 10 | 11 | 12 | 13 | 14 | 15 | 16 | 17 | 18 | 19 |

TOLERANCES:*

| DECIMAL | FRACTIONAL | ANGULAR | DRAWING ORIGATION DATE | LAST MODIFICATION DATE |
|---------|------------|---------|------------------------|------------------------|
| ± 0.010 | ± 1/64 | ± 5° | 6/18/2001 | 4/1/2017 |

*All dimensions are in inches.

RoHS COMPLIANCE:

01-2550-1-01XX

| PART NUMBER | RoHS COMPLIANT |
|----------------|----------------|
| 25-2550-1-0110 | YES |
| 25-2550-1-0111 | YES |
| 25-2550-1-0112 | YES |
| 25-2550-1-0113 | YES |
| 25-2550-1-0114 | YES |
| 25-2550-1-0115 | YES |
| 25-2550-1-0116 | YES |
| 25-2550-1-0117 | YES |
| 25-2550-1-0118 | YES |
| 25-2550-1-0119 | YES |

01-2550-1-02XX

| PART NUMBER | RoHS COMPLIANT |
|----------------|----------------|
| 25-2550-1-0210 | YES |
| 25-2550-1-0211 | YES |
| 25-2550-1-0212 | YES |
| 25-2550-1-0213 | YES |
| 25-2550-1-0214 | YES |
| 25-2550-1-0215 | YES |
| 25-2550-1-0216 | YES |
| 25-2550-1-0217 | YES |
| 25-2550-1-0218 | YES |
| 25-2550-1-0219 | YES |

01-2550-1-03XX

| PART NUMBER | RoHS COMPLIANT |
|----------------|----------------|
| 25-2550-1-0310 | YES |
| 25-2550-1-0311 | YES |
| 25-2550-1-0312 | YES |
| 25-2550-1-0313 | YES |
| 25-2550-1-0314 | YES |
| 25-2550-1-0315 | YES |
| 25-2550-1-0316 | YES |
| 25-2550-1-0317 | YES |
| 25-2550-1-0318 | YES |
| 25-2550-1-0319 | YES |

01-2550-1-044XX

| PART NUMBER | RoHS COMPLIANT |
|-----------------|----------------|
| 25-2550-1-04410 | YES |
| 25-2550-1-04411 | YES |
| 25-2550-1-04412 | YES |
| 25-2550-1-04413 | YES |
| 25-2550-1-04414 | YES |
| 25-2550-1-04415 | YES |
| 25-2550-1-04416 | YES |
| 25-2550-1-04417 | YES |
| 25-2550-1-04418 | YES |
| 25-2550-1-04419 | YES |

NOTES:

DATASHEET NOTES

RATED: 15 AMPERES CAPACITY, 5000 WVDC MAXIMUM. STANDARD SIZE STACKING BANANA PLUGS/JACKS. SET SCREWS PART NUMBER: 701-7192.

INSTRUCTION NOTES

WIRE LEADS AND/OR COMPONENTS IS INSERTED THRU SIDE HOLE AND IS FIRMLY SECURED IN PLACE WITH SET SCREW (ZINC PLATED STEEL, 8-32 x 3/16").
