

PART NAME

NEMA 4X DIE-CAST ALUMINUM BOX w/MTG. BRKTS.

PART No.

AN-2855 &amp; AN-2855-B

REVISION DATE

11-15-11

MATERIAL: ALUMINUM ALLOY #ADC-12

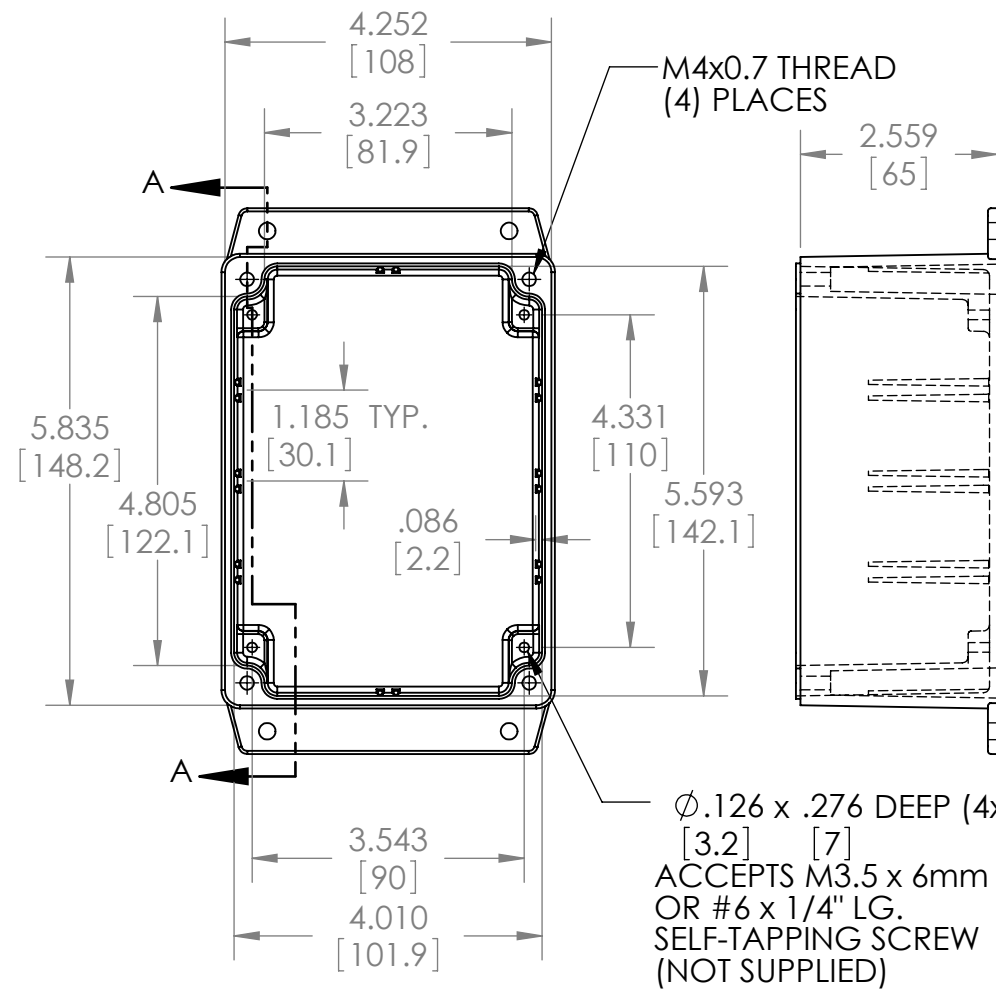
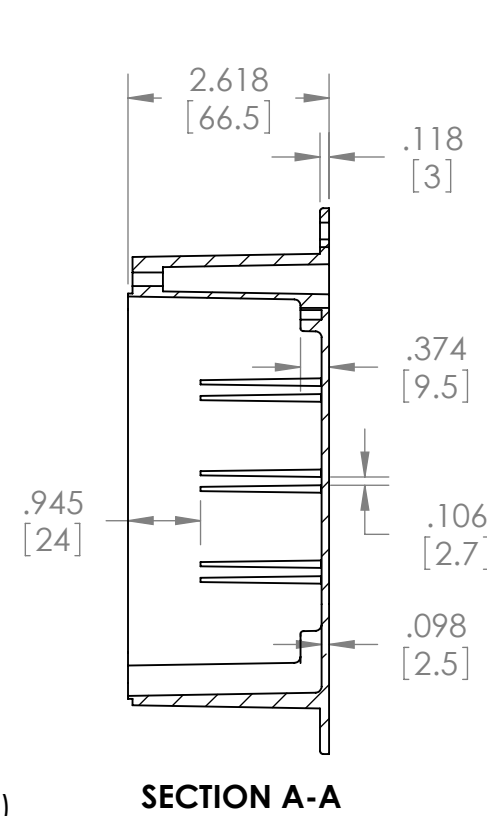
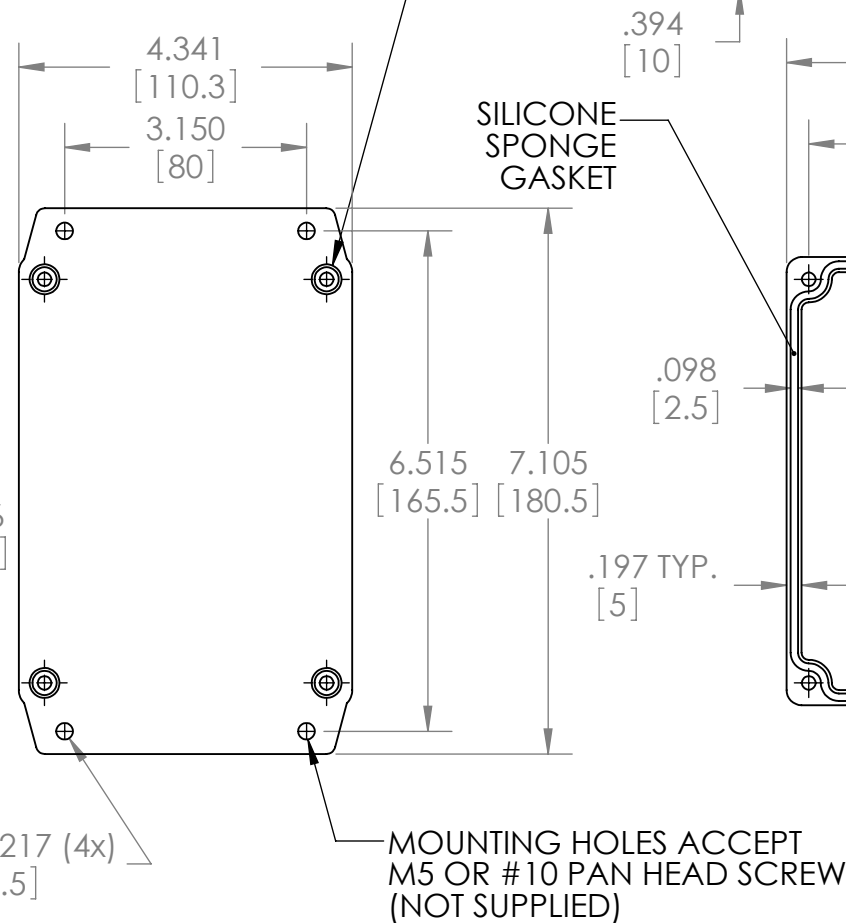
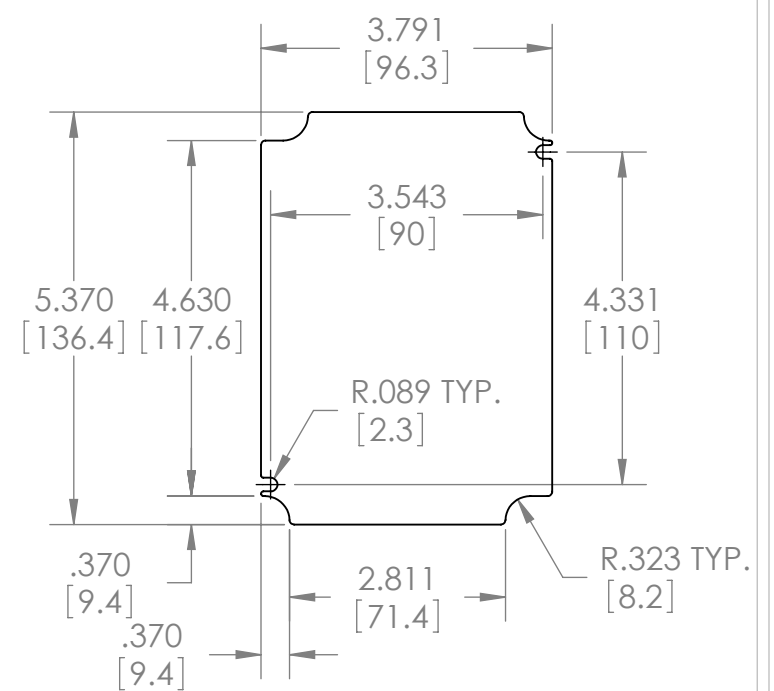
FINISH: NATURAL (NO SUFFIX)  
SMOOTH BLACK (SUFFIX -B)**BODY****SECTION A-A****COVER****SUGGESTED PC BOARD LAYOUT****NOTES:**

- 1.) FOUR (4) M4x0.7 x 20mm (.79") LG. CSK. HEAD STAINLESS STEEL SCREWS SUPPLIED FOR ASSEMBLY OF COVER TO BODY.
- 2.) ALL HOLE DIAMETERS HAVE  $\pm .005$  [ $\pm .13$ ] TOLERANCE  
ALL OTHER DIMENSIONS HAVE  $\pm .015$  [ $\pm .38$ ] TOLERANCE
- 3.) ALL OUTSIDE AND INSIDE DRAFT ANGLE: 1°

