

PTS0805

6-24 Volt DC surface mount resettable PTC devices

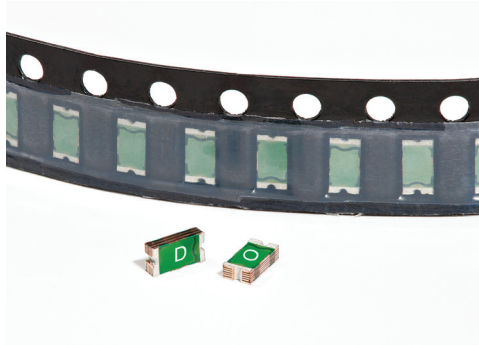

Product features

- Positive temperature coefficient (PTC)
- SMT resettable device
- Low resistance
- 6 to 24 volts
- Current ratings from 0.1 A to 0.75 A
- Fast time-to-trip
- Small EIA size 0805 (2012 metric) footprint

Applications

- USB Peripherals
- Disk drives
- Power tools
- Rechargeable battery pack protection
- Plug and play protection for motherboards and peripherals
- Mobile phones - battery and port protection
- Game console port protection
- Digital cameras
- Set-top boxes
- Tablets/notebooks/netbooks

Agency information

- cURus Recognized card, File No: E343021
- TÜV, File: R 50283843

Part number system/ordering:

PT S 0805 6V 035

- PT = PolyTron™ PTC device series
- S = Surface mount
- 0805 = Dimension code
- 6V = Maximum voltage
- 035 = Current hold (I_{hold})

Product specifications- (+23 °C)

Catalog number	Part marking	V _{max} (Vdc)	I _{max} (A)	I _{hold} (A)	I _{trip} (A)	P _d max. (W)	Time to trip (max.)		Resistance (Ω)		Agency information	
									Initial (R _i)	Post trip (R _t)		
							(A)	(sec)	min.	max.	cURus	TUV
PTS080524V010	D	24	100	0.1	0.30	0.6	0.5	1.5	1.0	6.0	X	X
PTS08059V020	L	9	100	0.2	0.50	0.5	8.0	0.05	0.65	3.5	X	X
PTS08056V035	T	6	100	0.35	0.75	0.5	8.0	0.1	0.25	1.2	X	X
PTS08056V050	O	6	100	0.5	1.00	0.5	8.0	0.2	0.15	0.85	X	X
PTS08056V075	X	6	100	0.75	1.50	0.5	8.0	0.3	0.09	0.40	X	X

Notes:
 I_{hold} – Hold current: Maximum current device will pass without interruption in +23 °C still air.
 I_{trip} – Trip current: Minimum current that will switch the device from low resistance to high resistance in +23 °C still air.
 V_{max}: Maximum continuous voltage device can withstand without damage at rated current.
 I_{max}: Maximum fault current device can withstand without damage at rated voltage.
 P_d: Power dissipated from device when in the tripped state in +23 °C still air.
 R_i (min.): Minimum resistance of device as supplied at +23 °C unless otherwise specified.
 R_t (max.): Maximum resistance of device when measured one hour post reflow (SMD) or one hour post trip (radial-leaded device) at +23°C unless otherwise specified.

Dimensions - mm

Part number	C max.
PTS080524V010	1.00
PTS08059V020	1.00
PTS08056V035	0.75
PTS08056V050	1.25
PTS08056V075	1.25

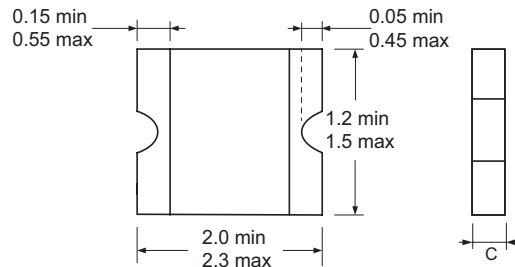

Recommended land pattern - mm (in)

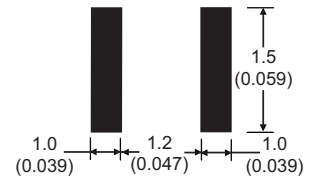

Environmental specifications

Characteristic	Value
Operating temperature range	-40 °C to +85 °C
Surface temperature in tripped state	+125 °C max.
Thermal shock	+85 °C to -40 °C, 20 cycles, -33% typical resistance change
Solvent resistance	MIL-STD-202 Method 215, no change
Humidity age test	Specified temperature (+23 °C ± 3 °C)+85 °C, 85% RH, 100 hours ±5% typical resistance change.
Storage temperature range	-10 °C to +40 °C
Storage duration	One year
Storage relative humidity	≤75%
Storage conditions	Keep away from corrosive atmosphere and sunlight

Terminal material:

- Nickel/tin-plated copper

Time to trip curves at +23°C

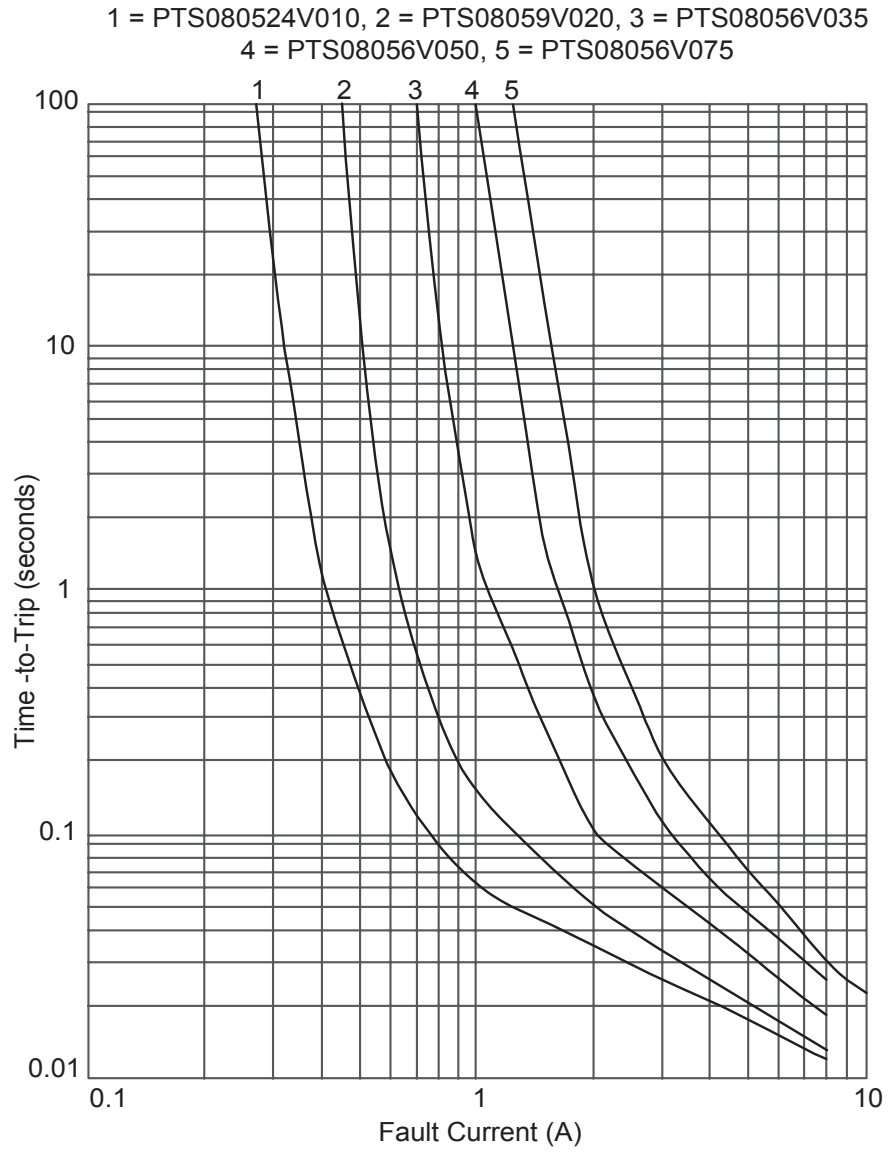

Temperature derating curve

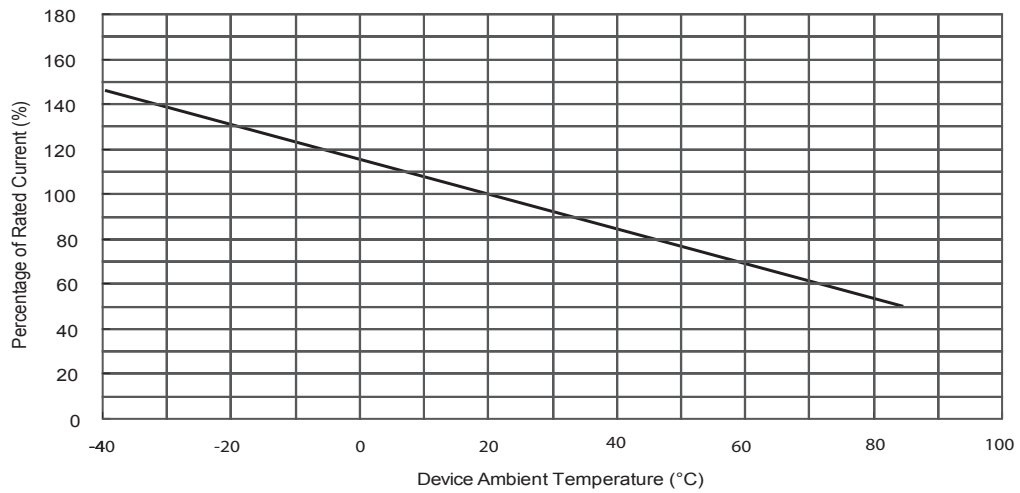

Packaging information - mm

4000 devices per 178 mm diameter reel

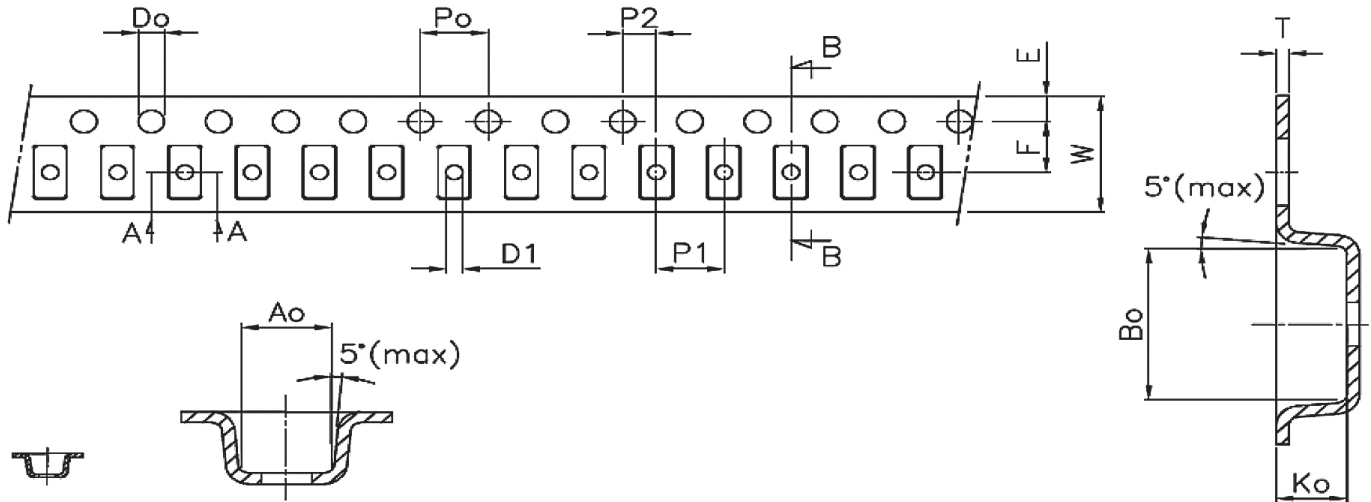

A0	B0	K0	P0	P1	P2	T	E	F	D0	D1	W	10P0
±0.10	±0.10	±0.10	±0.10	±0.10	±0.05	±0.05	±0.10	±0.05	±0.10	Min.	±0.10	±0.20
1.6	2.3	0.9	4.0	4.0	2.0	0.25	1.75	3.5	1.5	1.0	8.1	40.0

Reel specifications

4000 devices per 178 mm diameter reel

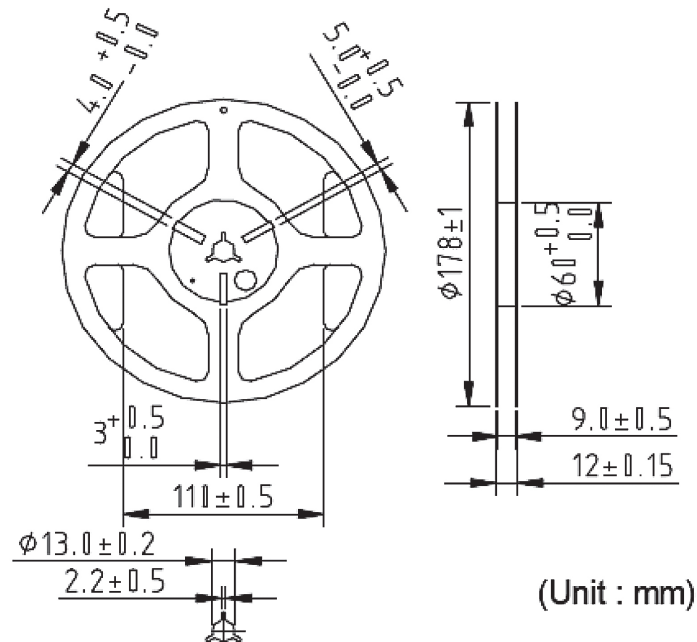

Solder reflow profile

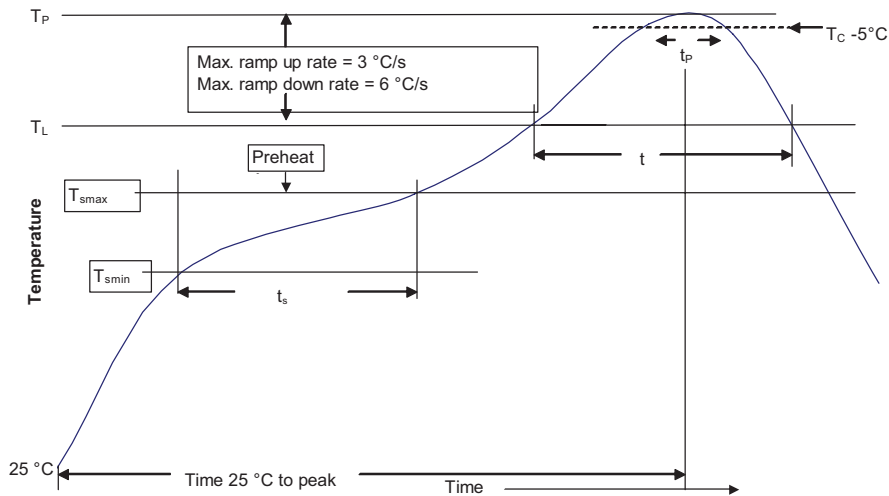

Table 1 - Standard SnPb solder (T_C)

Package thickness	Volume mm ³ <350	Volume mm ³ ≥350
<2.5 mm	235 °C	220 °C
≥2.5 mm	220 °C	220 °C

Table 2 - Lead (Pb) free solder (T_C)

Package thickness	Volume mm ³ <350	Volume mm ³ 350 - 2000	Volume mm ³ >2000
<1.6 mm	260 °C	260 °C	260 °C
1.6 - 2.5 mm	260 °C	250 °C	245 °C
>2.5 mm	250 °C	245 °C	245 °C

Reference J-STD-020

Profile feature	Standard SnPb solder	Lead (Pb) free solder
Preheat and soak		
• Temperature min. (T_{smin})	100 °C	150 °C
• Temperature max. (T_{smax})	150 °C	200 °C
• Time (T_{smin} to T_{smax}) (t_s)	60-120 seconds	60-120 seconds
Ramp up rate T_L to T_P	3 °C/ second max.	3 °C/ second max.
Liquidous temperature (T_L)	183 °C	217 °C
Time (t_L) maintained above T_L	60-150 seconds	60-150 seconds
Peak package body temperature (T_P)*	Table 1	Table 2
Time (t_p)* within 5 °C of the specified classification temperature (T_C)	20 seconds*	30 seconds*
Ramp-down rate (T_P to T_L)	6 °C/ second max.	6 °C/ second max.
Time 25 °C to peak temperature	6 minutes max.	8 minutes max.

* Tolerance for peak profile temperature (T_P) is defined as a supplier minimum and a user maximum.

Wave solder

Reservoir temperature: 260 °C

Time in reservoir: 10 seconds maximum

Life Support Policy: Eaton does not authorize the use of any of its products for use in life support devices or systems without the express written approval of an officer of the Company. Life support systems are devices which support or sustain life, and whose failure to perform, when properly used in accordance with instructions for use provided in the labeling, can be reasonably expected to result in significant injury to the user.

Eaton reserves the right, without notice, to change design or construction of any products and to discontinue or limit distribution of any products. Eaton also reserves the right to change or update, without notice, any technical information contained in this bulletin.

Eaton
Electronics Division
1000 Eaton Boulevard
Cleveland, OH 44122
United States
Eaton.com/electronics

© 2019 Eaton
All Rights Reserved
Printed in USA
Publication No. 10130 PCN19016
November 2019

Eaton is a registered trademark.

All other trademarks are property of their respective owners.

Follow us on social media to get the latest product and support information.

