

FP1012V

High frequency, high current power inductors



Product features

- Vertical design utilizes less board space
- High current carrying capacity
- Operating frequency up to 3 MHz
- Inductance range from 70 nH to 470 nH
- Current range 22 A to 130 A
- 10.0 mm x 6.2 mm footprint surface mount package in 12 mm height
- Moisture sensitivity level (MSL): 1
- Ferrite core material
- Weight: 3.1 grams typical

Applications

- Multi-phase and Vcore regulators
- Voltage regulator modules (VRMs) and high power density VRMs
 - Server and desktop
 - Central processing unit (CPU)
 - Graphics processing unit (GPU)
 - Application specific integrated circuit (ASIC)
- Data networking and storage systems
- Graphics cards and battery power systems
- Point-of-Load modules

Environmental compliance and general specifications

- Storage temperature range (component): -40 °C to +125 °C
- Operating temperature range: -40 °C to +125 °C (ambient plus self-temperature rise)
- Solder reflow temperature: J-STD-020 (latest revision) compliant



Product specifications

Part number ⁵	OCL ¹ (nH) ±10%	FLL ² (nH) minimum	I _{RM1} ³ (A)	I _{RM1} ¹⁴ (A)	I _{RM2} ⁵ (A)	I _{RM3} ⁶ (A)	DCR (mΩ) @ +20 °C ±10%	K-factor ⁷	Dimension B (mm) maximum
FP1012V2-R070-R	70	50	84	130+	130+	130+	0.125	305	6.2
FP1012V2-R080-R	80	57	84	130+	130+	125	0.125	305	6.1
FP1012V2-R090-R	90	64	84	130+	117	110	0.125	305	6.1
FP1012V2-R100-R	100	72	84	125	105	100	0.125	305	6.0
FP1012V2-R120-R	120	86	84	105	88	81	0.125	305	6.0
FP1012V2-R150-R	150	108	84	83	70	66	0.125	305	6.0
FP1012V2-R330-R	330	231	84	36	28	26	0.125	305	6.0
FP1012V2-R470-R	470 (±15%)	329	84	22	19	18	0.125	305	6.0

1. Open circuit inductance (OCL) test parameters: 100 kHz, 0.1 Vrms, 0.0 Adc, +25 °C

2. Full load inductance (FLL) test parameters: 100 kHz, 0.1 Vrms, I_{RM1}, +25 °C

3. I_{RM1}: DC current for an approximate temperature rise of 40 °C without core loss. Derating is necessary for AC currents.

PCB layout, trace thickness and width, air-flow, and proximity of other heat generating components will affect the temperature rise. It is recommended that the temperature of the part not exceed +125 °C under worst case operating conditions verified in the end application.

4. I_{RM1}: Peak current for approximately 20% rolloff @ +25 °C

5. I_{RM2}: Peak current for approximately 20% rolloff @ +100 °C

6. I_{RM3}: Peak current for approximately 20% rolloff @ +125 °C

7. K-factor: Used to determine Bp-p for core loss (see graph). Bp-p = K * L * ΔI * 10⁻³. Bp-p:(Gauss), K: (K-factor from table), L: (Inductance in nH), ΔI (Peak to peak ripple current in Amps).

8. Part number definition: FP1012Vx-Rxxx-R

FP1012 = Product code and size

Vx= Version indicator

Rxxx=Inductance value in μH, R=decimal point

-R suffix = RoHS compliant

Dimensions-mm

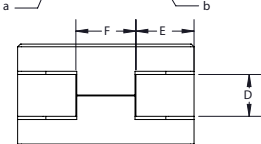
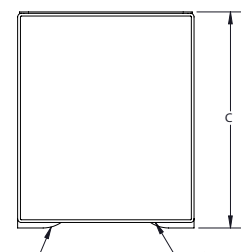
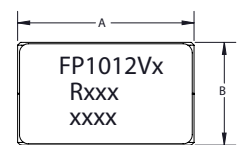

Recommended pad layout

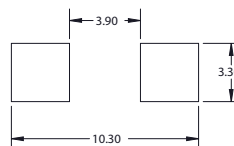

Schematic

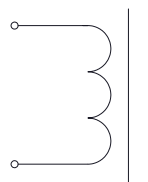

Dimension

Dimension	Value
A	10 maximum
B	See product specifications table
C	12 maximum
D	2.3 nominal
E	3.2 nominal
F	3.3 nominal

Part marking: FP1012=Product code and size, Vx=Version indicator, Rxxx= inductance value in μH,

R=decimal point, xxxx= lot code

Tolerances are ±0.15 millimeters unless stated otherwise

All soldering surfaces to be coplanar within 0.1 millimeters

Pad layout tolerances are ±0.1 millimeters unless stated otherwise

DCR is measured from point "a" to point "b"

Traces or vias underneath the inductor is not recommended

Packaging information- mm

Supplied in tape and reel packaging, 250 parts per 13" diameter reel

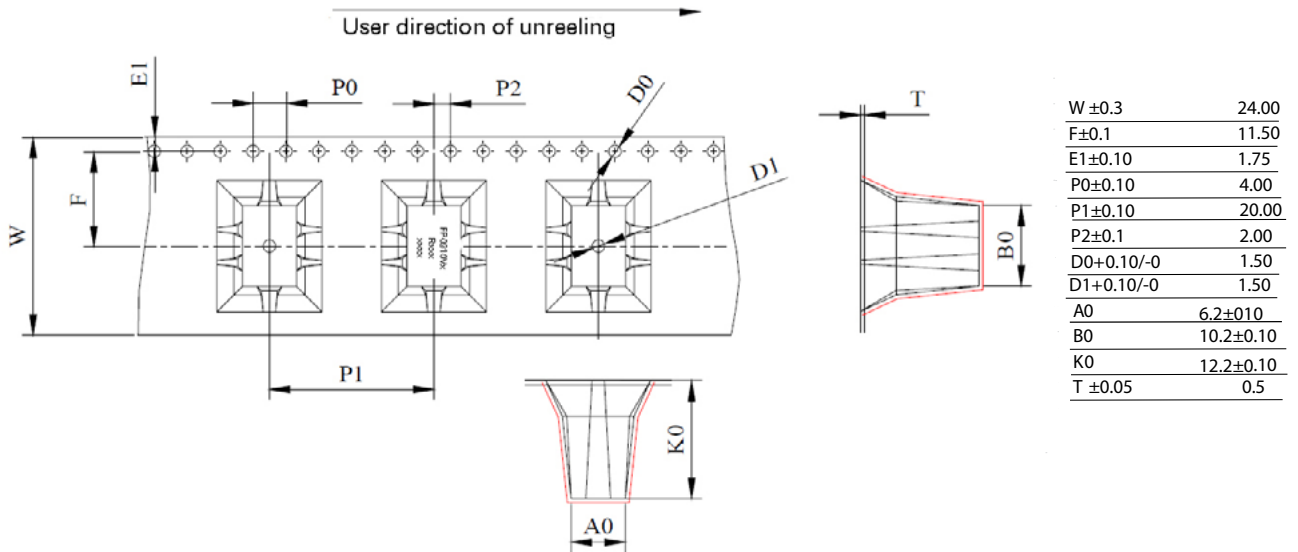

Temperature rise vs. total loss

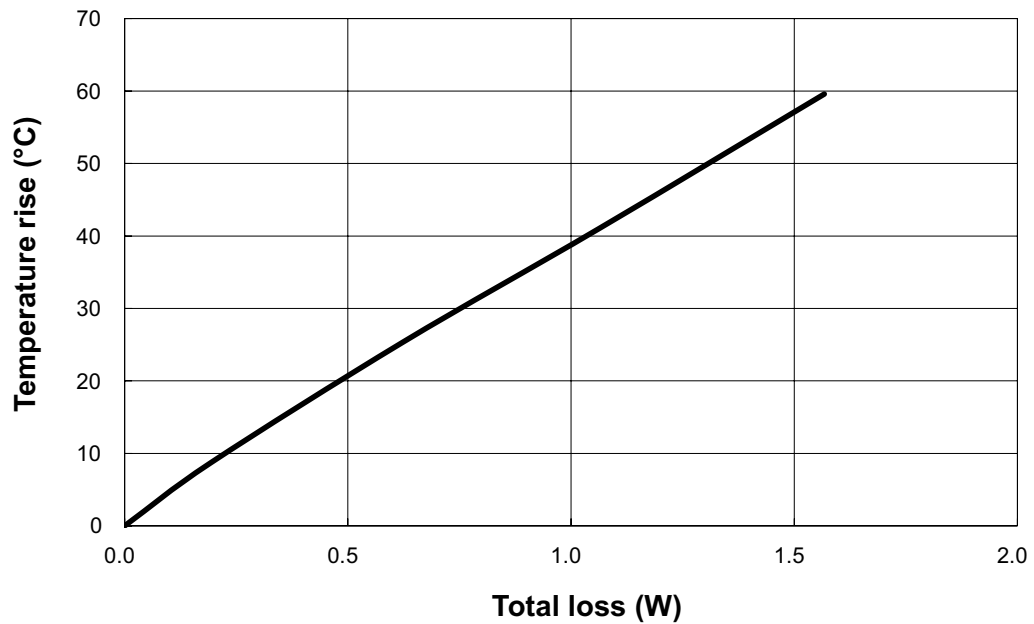

Core loss vs Bp-p

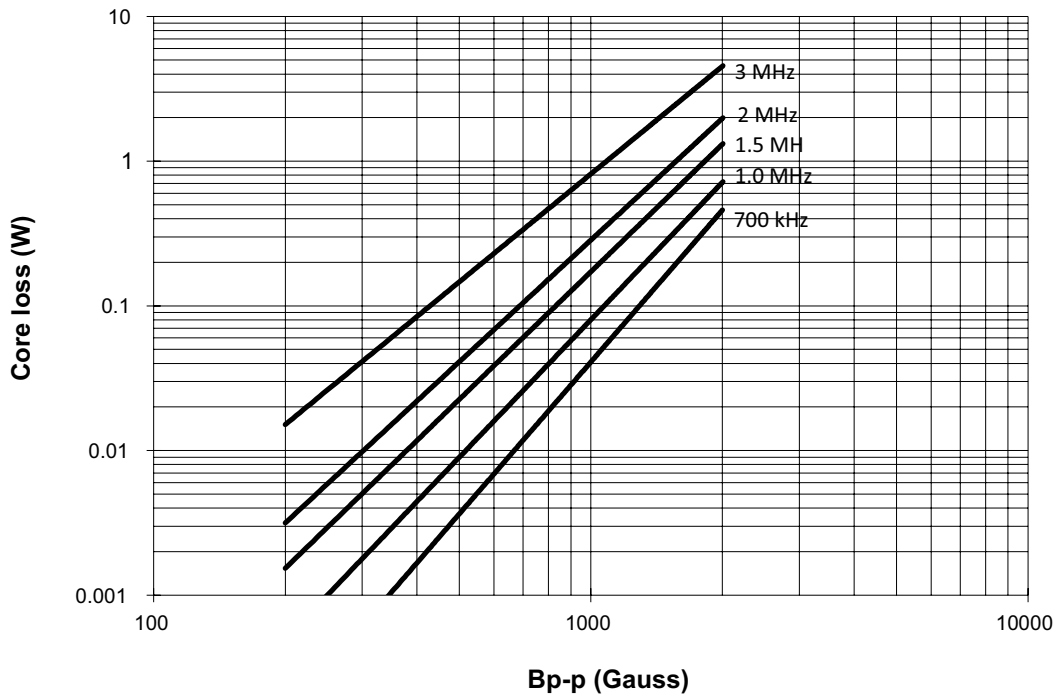

Inductance characteristics

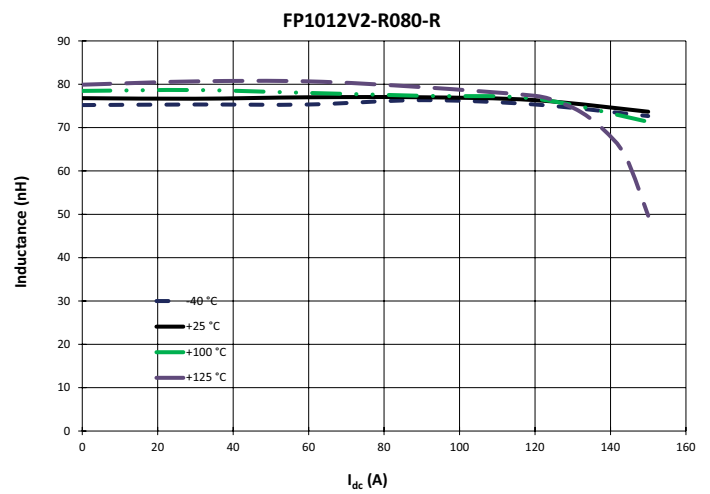
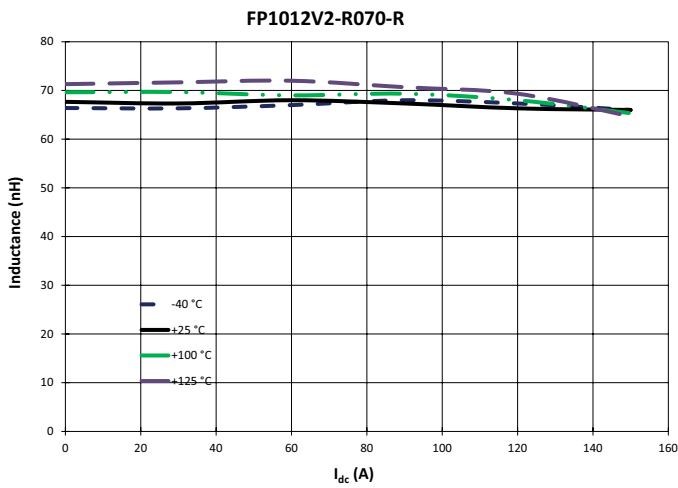

Inductance characteristics

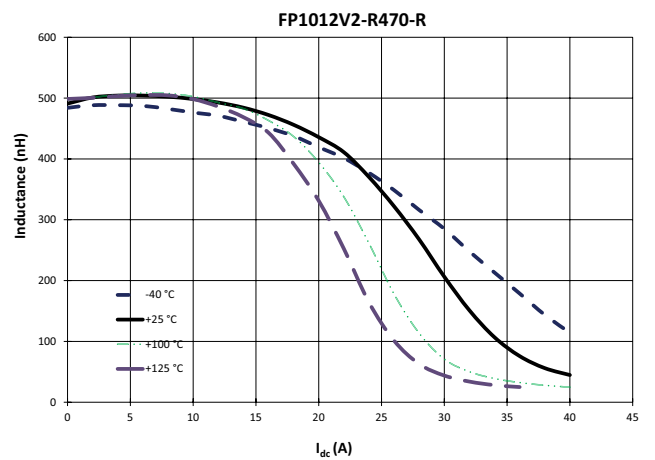
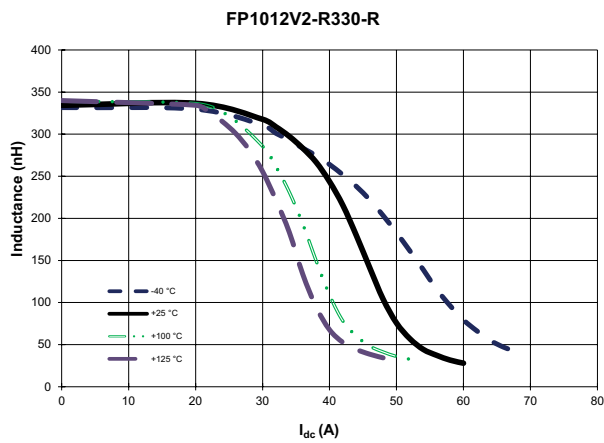
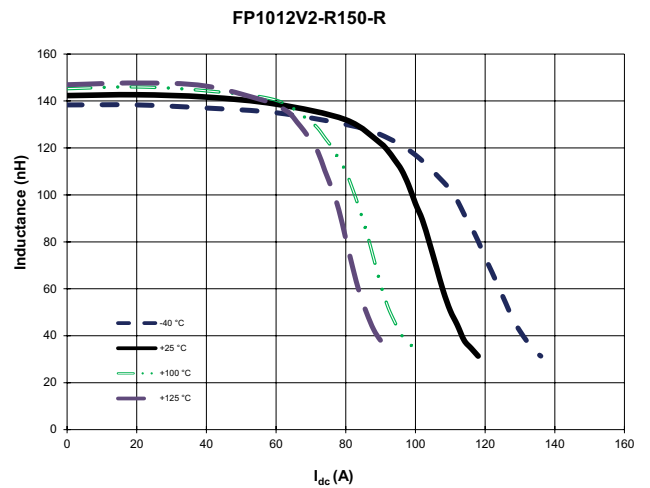
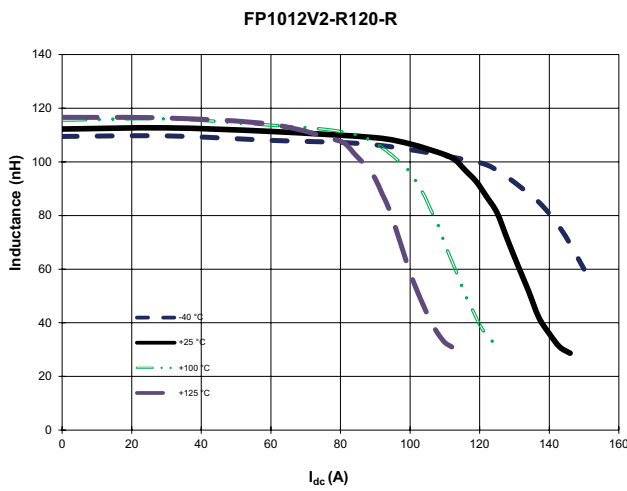
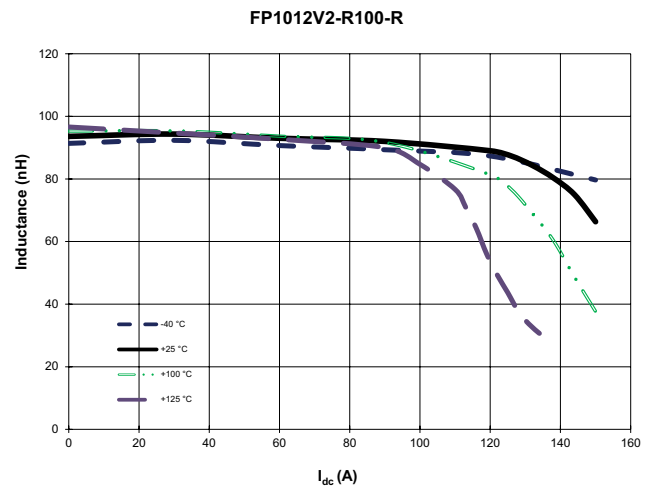
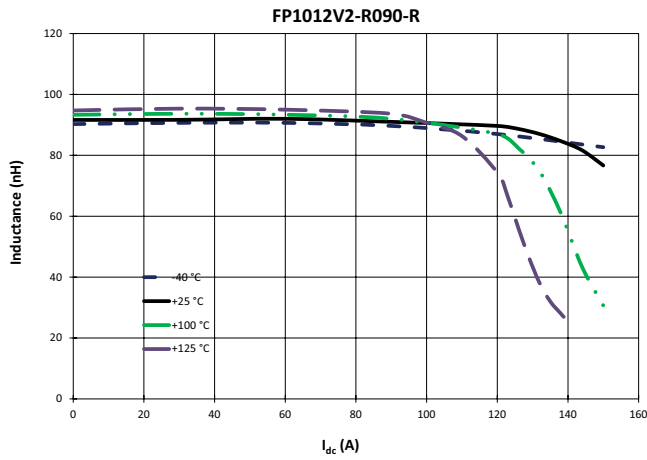

Solder reflow profile

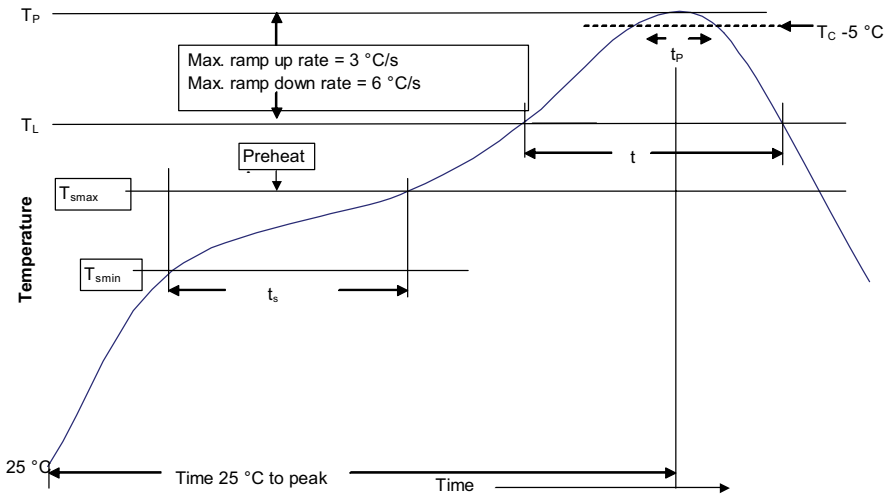

Table 1 - Standard SnPb solder (T_C)

Package thickness	Volume mm ³ <350	Volume mm ³ ≥350
<2.5 mm)	235 °C	220 °C
≥2.5 mm	220 °C	220 °C

Table 2 - Lead (Pb) free solder (T_C)

Package thickness	Volume mm ³ <350	Volume mm ³ 350 - 2000	Volume mm ³ >2000
<1.6 mm	260 °C	260 °C	260 °C
1.6 – 2.5 mm	260 °C	250 °C	245 °C
>2.5 mm	250 °C	245 °C	245 °C

Reference J-STD-020

Profile feature	Standard SnPb solder	Lead (Pb) free solder
Preheat and soak		
• Temperature min. (T _{Smin})	100 °C	150 °C
• Temperature max. (T _{Smax})	150 °C	200 °C
• Time (T _{Smin} to T _{Smax}) (t _s)	60-120 seconds	60-120 seconds
Ramp up rate T _L to T _P	3 °C/ second max.	3 °C/ second max.
Liquidous temperature (T _L)	183 °C	217 °C
Time (t _L) maintained above T _L	60-150 seconds	60-150 seconds
Peak package body temperature (T _P)*	Table 1	Table 2
Time (t _p)* within 5 °C of the specified classification temperature (T _C)	20 seconds*	30 seconds*
Ramp-down rate (T _P to T _L)	6 °C/ second max.	6 °C/ second max.
Time 25 °C to peak temperature	6 minutes max.	8 minutes max.

* Tolerance for peak profile temperature (T_P) is defined as a supplier minimum and a user maximum.

Life Support Policy: Eaton does not authorize the use of any of its products for use in life support devices or systems without the express written approval of an officer of the Company. Life support systems are devices which support or sustain life, and whose failure to perform, when properly used in accordance with instructions for use provided in the labeling, can be reasonably expected to result in significant injury to the user.

Eaton reserves the right, without notice, to change design or construction of any products and to discontinue or limit distribution of any products. Eaton also reserves the right to change or update, without notice, any technical information contained in this bulletin.

Eaton
Electronics Division
1000 Eaton Boulevard
Cleveland, OH 44122
United States
Eaton.com/electronics

© 2020 Eaton
All Rights Reserved
Printed in USA
Publication No. 10953 BU-MC19083
February 2020

Eaton is a registered trademark.
All other trademarks are property of their respective owners.

Follow us on social media to get the latest product and support information.

