

Ultra Compact Servo Motor & Driver

# MINAS E Series



## 1 Best Fit to Small Drives

- Further evolution in down-sizing, by 47% in size (Note)
- Exclusively designed for Positioning Control

## 2 Easy to Handle, Easy to Use

- DIN-rail mounting unit (option) improves handling/installation.
- User-friendly Console makes the setup easy.
- High functionality Real-Time Auto-Gain Tuning enables adjustment-free operation.

## 3 High-Speed Positioning with Resonance Suppression Filters

- Built-In notch filter suppresses resonance of the machine.
- Built-in adaptive filter detect resonance frequency and suppress vibration.

## 4 Smoother operation for Low Stiffness Machine

- Damping control function suppresses vibration during acceleration/deceleration

# MINAS E Series

## Contents

●Features .....	E1
●Details of Features .....	E3
●List of Specifications .....	E5
●Model Designation .....	E6
●Wiring Example .....	E7
●Table of Part Numbers and Options .....	E7
●Conformity to CE and UL .....	E9
●Motor	
<Ratings/Specifications/Torque Characteristics> .....	E11
MUMA .....	E11
<Dimensions> .....	E15
MUMA .....	E15
●Motor with Gear Reducer/MUMA	
<General Specifications> .....	E16
<Ratings/Specifications> .....	E17
<Torque Characteristics> .....	E18
<Dimensions> .....	E19
●Driver	
<Common Specifications> .....	E20
<Standard Wiring Example of Main Circuit> .....	E21
<Encoder Wiring Diagram> .....	E21
<Standard Wiring Example of Control Circuit> .....	E22
<Dimensions> .....	E23
●Options .....	E24
●Recommended components .....	E30

Remarks : Instruction manual is available as an option as  
 Japanese version : DV0P3680 and  
 English version : DV0P3700

# Details of Features

## 1. Easy to Handle, East to Use

### High-functionality Real-Time Auto-Gain Tuning (Note 1)

- Offers real automatic gain tuning to low and high stiffness machines with a combination of an adaptive filter.
- Supports the vertical axis application where the load torque is different in rotational direction.

### DIN-rail mounting unit (option)

- Easy to mount and easy to dismount.

## 2. Further Reduction of Vibration

### Adaptive filter (Note1)

- Makes the notch filter frequency automatically follow the machine resonance frequency in real-time auto-gain tuning.
- Suppression of "Judder" noise of the machine can be expected which is caused by variation of the machines or resonance frequency due to aging.

### Notch filter (Note1)

- 1-channel notch filters are equipped in the driver independent from adaptive filter.
- Each of 2 filters can set up frequency and notch width, and frequency in 1Hz unit.  
Suppression of "Judder" noise of the machine which has multiple resonance points can be expected.

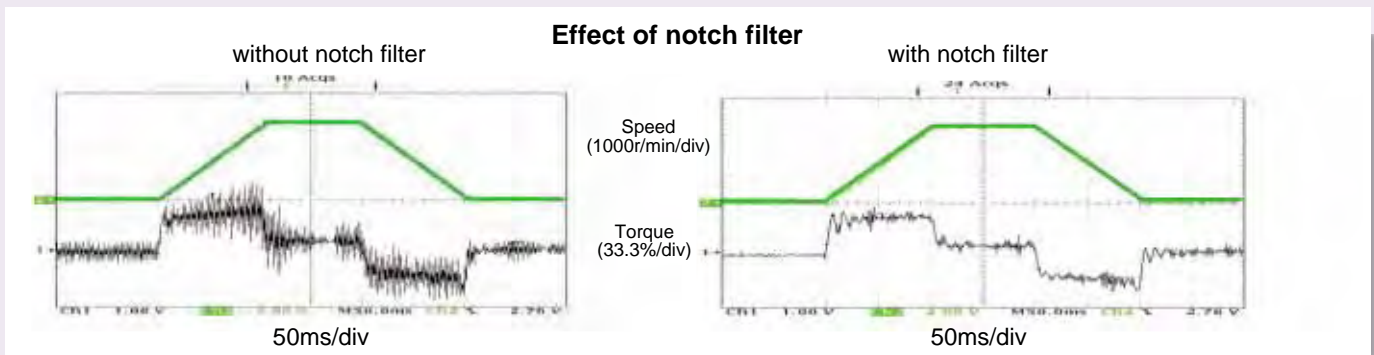

### Damping control (Note1)

- You can suppress vibration occurring at both starting and stopping in low stiffness machine, by manually setting up vibration frequency in 0.1Hz unit.  
Note) Only applies to manual adjustment

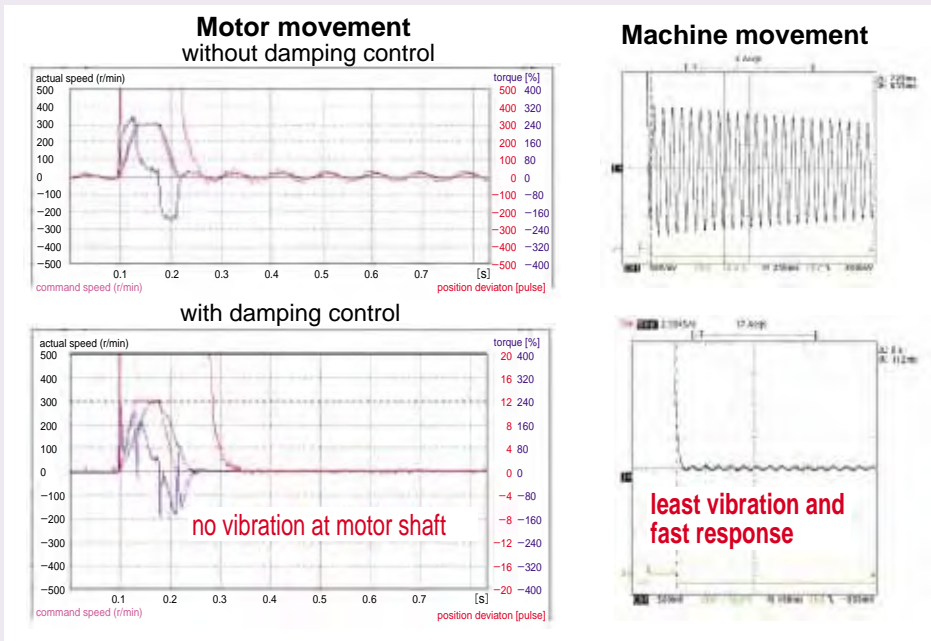

(Note1)  
Select at positioning action mode.  
· At high speed positioning mode (Pr02=0)  
Select either one of notch filter, damping control or high-functionality real-time auto-gain tuning. Not possible to use them all at the same time. Adaptive filter cannot be used.  
· At high-functionality positioning mode (Pr02=1)  
All of notch filter, damping control, high-functionality real-time auto-gain tuning and adaptive filter can be used at the same time.

## 3. Further Flexibility and Multiplicity

### ■ Console (Option)

- You can set up parameters, copy and make a JOG run.
- Convenient for maintenance at site.
- Refer to Page E25, Options.

### ■ Command control modes

- Offers 2 command modes, "Position control" and "Internal velocity control".
- You can make a 4-speed running at preset values with parameter at internal velocity control.

### ■ Inrush current suppressing function

- Inrush suppressing resistor is equipped in this driver, which prevent the circuit breaker shutdown of the power supply caused by inrush current at power-on.
- Prevents unintentional shutdown of the power supply circuit breaker in multi axis application and does not give load to the power line.

### ■ Regeneration discharging function

- Discharges the regenerative energy with resistor, which energy is generated while stopping the load with large moment of inertia, or use in up-down operation, and is returned to the driver from the motor.
- No regenerative resistor is installed in the driver.
- It is highly recommended to install an external regenerative resistor (option).

### ■ Built-in dynamic brake

- You can select the dynamic brake action which short the servo motor windings of U, V and W, at Servo-OFF, CW/CCW over-travel inhibition, power shutdown and trip.
- You can select the action sequence set up depending on the machine requirement.

### ■ Setup support software

- With the setup support software, "PANATERM<sup>®</sup>" via RS232 / RS485 communication port, you can monitor the running status of the driver and set up parameters.  
Note) Refer to page, F4 for setup support software.

### ■ Key-way shaft and tapped shaft end

- East pulley attachment and easy maintenance
- Attache screw to the tapped shaft to prevent key or pulley from being pulled out.

### ■ Wave-form graphic function

- With the setup support software, "PANATERM<sup>®</sup>", you can monitor the "Command speed", "Actual speed", "Torque", "Position deviation" and "Positioning complete signal".
- Helps you to analyze the machine and shorten the setup time  
\*Note) Refer to page "F4" for setup support software.

### ■ Frequency analyzing function

- You can confirm the response frequency characteristics of total machine mechanism including the servo motor with the setup support software, "PANATERM<sup>®</sup>".
- Helps you to analyze the machine and shorten the setup time.  
\*Note) Refer to page "F4" for setup support software.

### ■ Torque limit switching function

- You can select 2 preset torque limit value from external input.
- Use this function for tension control or press-hold control.

### ■ Conformity to CE and UL Standards



Subject	Standard conformed	
Motor	IEC60034-1 IEC60034-5 UL1004 CSA22.2 NO.100	Conforms to Low-Voltage Directives
	EN50178 UL508C	
Motor and driver	EN55011 Radio Disturbance Characteristics of Industrial, Scientific and Medical (ISM) Radio-Frequency Equipment	Conforms to references by EMC Directives
	EN61000-6-2 Immunity for Industrial Environments	
	IEC61000-4-2 Electrostatic Discharge Immunity Test	
	IEC61000-4-3 Radio Frequency Electromagnetic Field Immunity Test	
	IEC61000-4-4 Electric High-Speed Transition Phenomenon/Burst Immunity Test	
	IEC61000-4-5 Lightning Surge Immunity Test	
	IEC61000-4-6 High Frequency Conduction Immunity Test	
IEC61000-4-11 Instantaneous Outage Immunity Test		

IEC : International Electrotechnical Commission  
 EN : Europaischen Normen  
 EMC : Electromagnetic Compatibility  
 UL : Underwriters Laboratories  
 CSA : Canadian Standards Association

# List of Specifications

Motor series	Rated output (kW)	Rated rotational speed (Max. speed) (r/min)	Rotary encoder		Brake	Gear	UL/CSA	Enclosure	Features	Applications
			2500P/r incremental	17bit absolute/incremental	Holding	High precision				
Ultra low inertia	<b>MUMA</b>									
		<b>0.05 - 0.4</b> 0.05 0.1 0.2 0.4	3000 (5000)	○	—	○	○	○	IP65 (Except shaft throughhole and connector)	Small capacity Ultra low inertia

## Model Designation

### ■ Servo Motor

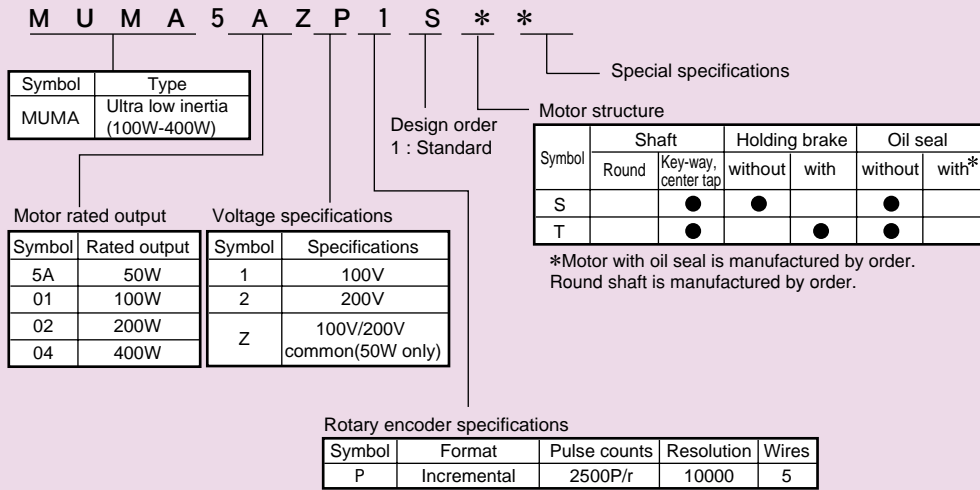

See page, E11 for motor specifications

### ■ Motor with gear reducer

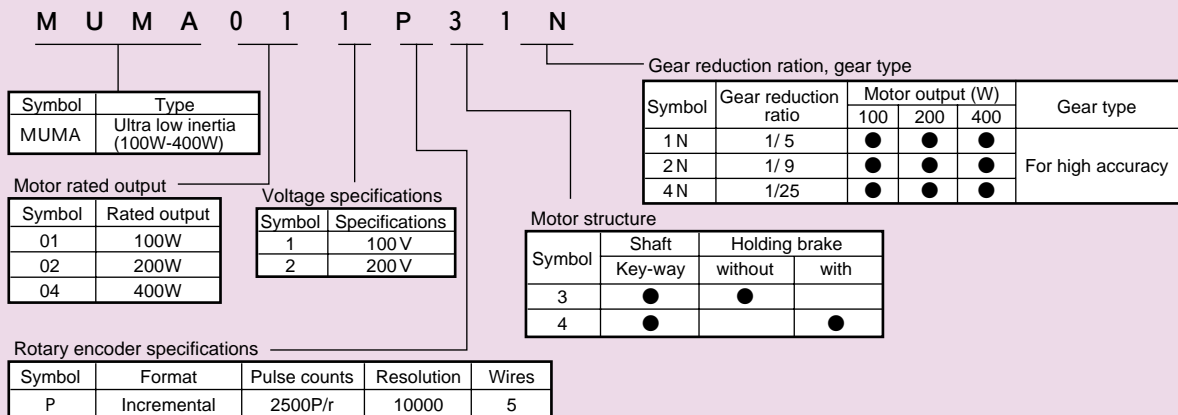

See page, E16 for motor with gear reducer specifications

### ■ Servo Driver

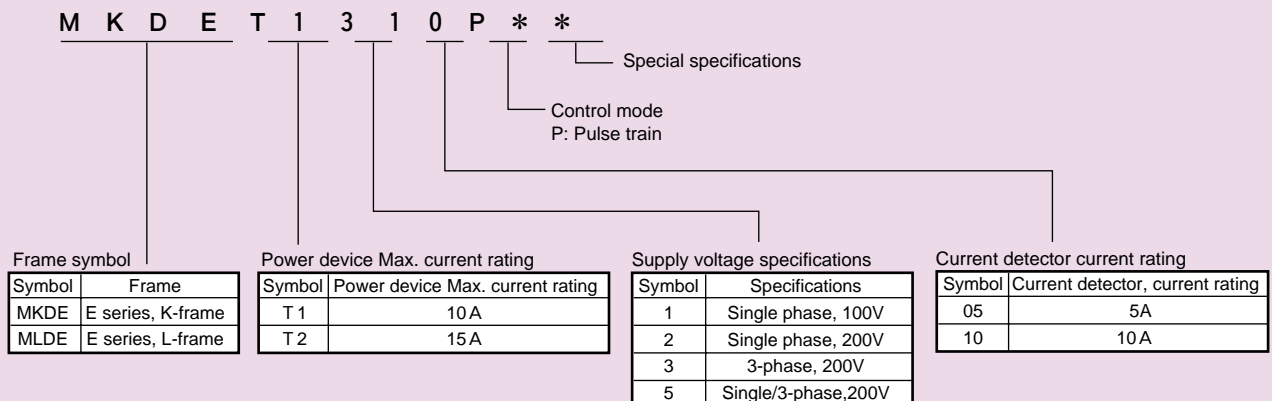

See page, E20 for driver specifications

# Wiring example For details, refer to the Instruction Manual.

## ●Wiring of main circuit

**Circuit Breaker (NFB)**  
Protects the power lines.  
Shuts off the circuit when overcurrent passes.

**Noise Filter (NF)**  
Prevents external noise from the power lines.  
And reduces an effect of the noise generated by the servo driver.

**Magnetic Contactor (MC)**  
Turns on/off the main power of the servo driver.  
Surge absorber to be used together with this.

**Reactor (L)**  
Reduces harmonic current of the main power.

**Pin-5 and Pin-3 of CN POWER**  
· Connect an external regenerative resistor (option) between Pin-5 and B (Pin-3) of connector, CN X5, when regenerative energy is large. (Refer to page, E31 for regenerative resistor.)

- Motor to page E11
- Driver to page E20
- Option to page E24
- Recommended equipments
- Parts customer to prepare

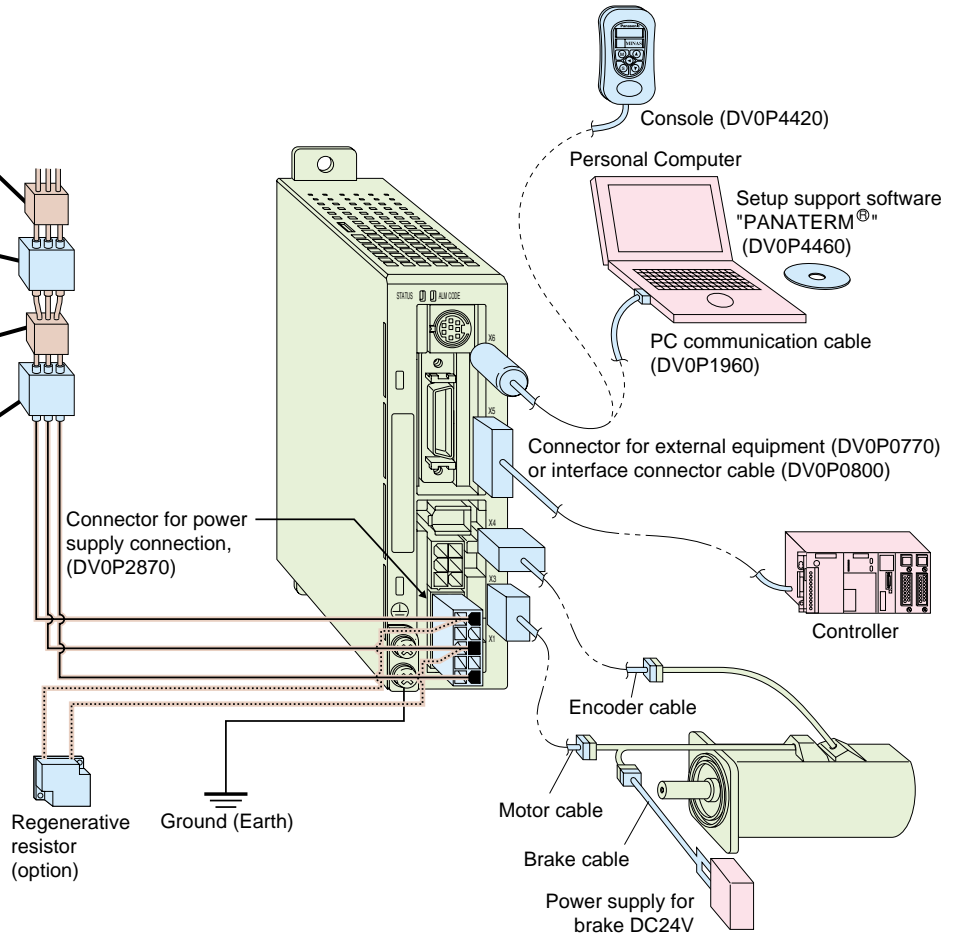

## Table of Part Numbers and Options

Power supply	Output (W)	2500P/r, Incremental				Encoder cable Note) 2	Motor cable Note) 2
		Motor Note) 1	Rating/Spec. (page)	Driver	Dimensions (Frame symbol)		
Single phase 100V	50	MUMA5AZP1□	E11	MKDET1105P	E23 (K)	MFECA0 * * 0EAM	MFMCA0 * * 0AEB
	100	MUMA011P1□	E11	MKDET1110P	E23 (K)		
	200	MUMA021P1□	E11	MLDET2110P	E23 (L)		
Single phase 200V	50	MUMA5AZP1□	E13	MKDET1505P	E23 (K)		
	100	MUMA012P1□	E13	MKDET1505P	E23 (K)		
	200	MUMA022P1□	E13	MLDET2210P	E23 (L)		
3-phase 200V	400	MUMA042P1□	E13	MLDET2510P	E23 (L)		
	50	MUMA5AZP1□	E13	MKDET1505P	E23 (K)		
		100	MUMA012P1□	E13	MKDET1505P	E23 (K)	
		200	MUMA022P1□	E13	MKDET1310P	E23 (K)	
400	MUMA042P1□	E13	MLDET2510P	E23 (L)			
			MLDET2310P				

Note 1. Motor model number suffix  
 S : Key way with center tap, without brake  
 T : Key way with center tap, with brake  
 2. \*\* represents cable length. For details, refer to page, E24

### List of recommended peripheral equipments

Power supply	Motor		Power capacity (at rated output)	Circuit breaker (Rated current)	Noise filter	Magnetic Contactor (Contact Composition)	Wire diameter (L1, L2, L3, U, V and W)
	Series	Output					
Single phase, 100V	MUMA	50W	0.3kVA	BBC25 (5A)	DV0P4160	BMFT61041N (3P+1a)	0.75mm <sup>2</sup> - 0.85mm <sup>2</sup> AWG18
		100W	0.4kVA				
		200W	0.5kVA	BBC2101N (10A)			
Single phase, 200V		50W	0.3kVA	BBC25N (5A)		BMFT61542N (3P+1a)	
		100W					
		200W	0.5kVA	BBC2101N (10A)			
3-phase 200V		400W	0.9kVA	BBC2101N (10A)		BMFT61042N (3P+1a)	
		50W	0.3kVA	BBC35N (5A)			
		100W					
	200W	0.5kVA	BBC3101N (10A)				

- Select the single and 3-phase common specifications corresponding to the power supplies.
- Circuit breaker and magnetic contactor listed are manufactured by Matsushita Electric Works.
- To conform to EC Directives, install a circuit breaker which conforms to IEC and UL Standards (UL listed and ® marked) between noise filter and power supply.
- For details of the noise filters, refer to page E10.

#### <Remarks>

- Use a copper conductor cables with temperature rating of 60°C or higher for main power connector and ground terminal wiring.
- Use a cable for ground with diameter of 2.0mm<sup>2</sup> (AWG14) or larger.

### Carrying page

Options		Part No.	Carrying page
Instruction manual	Japanese	DV0P3680	—
	English	DV0P3700	—
Console		DV0P4420	E25
Setup support software, PANATERM <sup>®</sup>	Japanese	DV0P4460	E28
	English		
RS232 communication cable (for connection with PC)		DV0P1960	E28
Interface cable		DV0P0800	E28
Connector kit for motor and encoder		DV0P0770	E27
Connector kit for external equipment		DV0P3670	E26
Connector kit for driver power supply		DV0P2870	E26
Encoder cable		MFECA0 * * 0EAM	E25
Motor cable		MFMCA0 * * 0AEB	E25
Brake cable		MFMCB0 * * 0GET	E25
Cable set (3m) (Note 3)		DV0P37300	E25
Cable set (5m) (Note 3)		DV0P39200	E25
DIN-rail unit		DV0P3811	E30
Regenerative resistor	100V	50 Ω 10W	DV0P2890
	200V	100 Ω 10W	DV0P2891
Reactor	100V		DV0P227
			DV0P228
	200V		DV0P220
Noise filter		DV0P4160	E10
Surge absorber	Single phase 100V, 200V	DV0P4190	E10
	3-phase 200V	DV0P1450	
Noise filter for signal wire		DV0P1460	E10

- Note) 3. Cable set (3m) contains,
- 1) Interface cable: DV0P0800
  - 2) Encoder cable (3m) : MFECA0030EAM
  - 3) Motor cable (3m) : MFMCA0030AEB
  - 4) Connector kit for driver power supply connection : DV0P2870
- Cable set (5m) contains,
- 1) Interface cable: DV0P0800
  - 2) Encoder cable (5m) : MFECA0050EAM
  - 3) Motor cable (5m) : MFMCA0050AEB
  - 4) Connector kit for driver power supply connection : DV0P2870

Option				
	Brake cable (Note) 2	Regenerative resistor	Reactor	Noise filter
MFMCB0 * * 0GET	DV0P2890	DV0P2891	DV0P227	DV0P4160
			DV0P228	
	DV0P2891	DV0P220		

# Conformity to CE and UL

## Compliance to EC and EMC Directives

### EC Directives

The EC Directives apply to all such electronic products as those having specific functions and have been exported to EU and directly sold to general consumers. Those products are required to conform to the EU unified standards and to furnish the CE marking on the products.

MINAS AC Servos conforms to the EC Directives for Low Voltage Equipment so that the machine incorporating our servos has an easy access to the conformity to relevant EC Directives for the machine.

### EMC Directives

MINAS Servo System conform to relevant standard under EMC Directives setting up certain model (condition) with certain locating distance and wiring of the servo motor and the driver. And actual working condition often differs from this model condition especially in wiring and grounding. Therefore, in order for the machine to conform to the EMC Directives, especially for noise emission and noise terminal voltage, it is necessary to examine the machine incorporating our servos.

### Conformed Standards

Subject	Conformed Standard		
Motor	IEC60034-1		Conforms to Low-Voltage Directives
	EN50178	UL508C	
Motor and driver	EN55011	Radio Disturbance Characteristics of Industrial, Scientific and Medical (ISM) Radio-Frequency Equipment	Conforms to references by EMC Directives
	EN61000-6-2	Immunity for Industrial Environments	
	IEC61000-4-2	Electrostatic Discharge Immunity Test	
	IEC61000-4-3	Radio Frequency Electromagnetic Field Immunity Test	
	IEC61000-4-4	Electric High-Speed Transition Phenomenon/Burst Immunity Test	
	IEC61000-4-5	Lightening Surge Immunity Test	
	IEC61000-4-6	High Frequency Conduction Immunity Test	
	IEC61000-4-11	Instantaneous Outage Immunity Test	

- IEC : International Electrotechnical Commission
- EN : Europaischen Normen
- EMC : Electromagnetic Compatibility
- UL : Underwriters Laboratories
- CSA : Canadian Standards Association

## Composition of peripheral components

<Precautions in using options>  
 Use options correctly after reading operation manuals of the options to better understand the precautions.  
 Take care not to apply excessive stress to each optional part.

### Installation environment

Use Minas driver in environment of Pollution Degree 1 or 2 prescribed in IEC-60664-1(e.g. Install the driver in control panel with IP54 protection structure.)

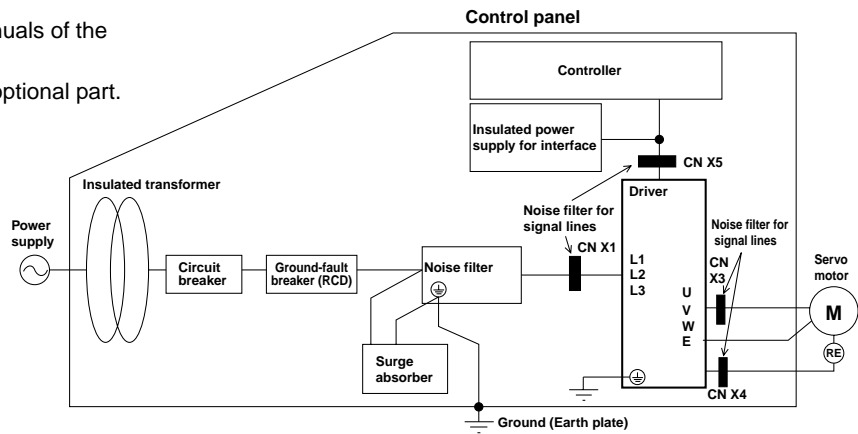

### Power supply

100V system : Single phase 100V	+ 10%	- 15%	- 115V	+ 10%	- 15%	50/60Hz
200V system : Single phase 200V	+ 10%	- 15%	- 240V	+ 10%	- 15%	50/60Hz
200V system : 3- phase 200V	+ 10%	- 15%	- 240V	+ 10%	- 15%	50/60Hz

- (1) Use the power supply under an environment of Overvoltage Category III specified in IEC60664-1.
- (2) For a interface power supply, use the insulated one with 12 to 24 VDC which conforms to CE Marking or EN Standards (EN60950).

### Circuit breaker

Connect a circuit breaker which conforms to IEC standards and is UL recognized (listed and marked), between the power supply and the noise filter.

## Noise filter

When you install one noise filter in the power supply for multi axis application, consult with the manufacture of the filter.

Option part No.	Part No.	Manufacturer
DV0P4160	3SUP-HU10-ER-6	Okaya Electric Industries Co.

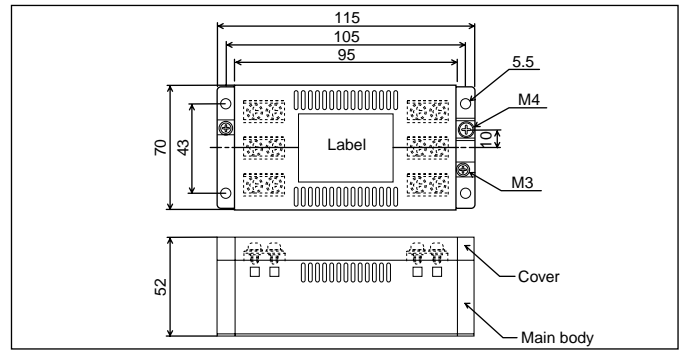

## Surge absorber

Install a surge absorber at primary side of the noise filter.

Option part No.	Driver voltage spec	Part No.	Manufacturer
DV0P1450	3-phase, 200V	R · A · V-781BXZ-4	Okaya Electric

Option part No.	Driver voltage spec	Part No.	Manufacturer
DV0P4190	Single phase, 100V, 200V	R · A · V-781BWZ-4	Okaya Electric

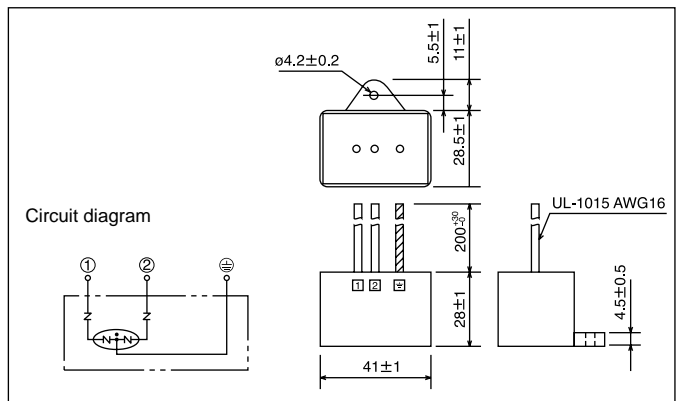
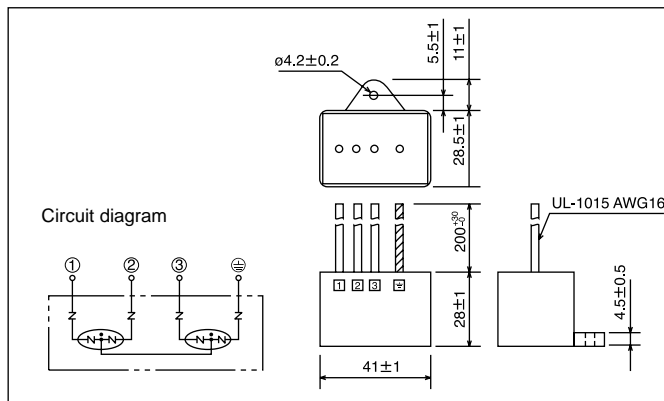

<Remarks>

Remove this surge absorber when you perform dielectric test on the machine, or surge absorber might be damaged.

## Noise filter for signal lines

Install noise filters for signal lines to all cables (Power line, motor cable, encoder cable, interface cable)

Option part No.	Part No.	Manufacturer
DV0P1460	ZCAT3035-1330	TDK Corp.

<Caution>

Fix the signal line noise filter in place to eliminate excessive stress to the cables.

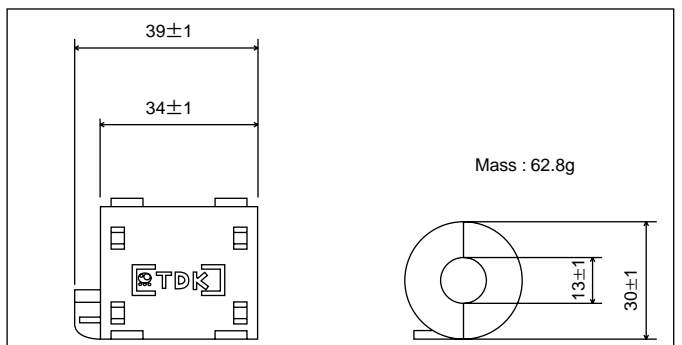

## Grounding



- Connect the protective earth terminal of the driver (⊕) and protective earth terminal of the control panel (PE) without fail to prevent electrical shocks.
- Do not co-clamp to the ground terminals (⊕). Two ground terminals are provided.

## Ground-fault breaker

Install a B-type ground-fault breaker (RCD) at primary side of the power supply of the driver.

## Conformity to UL Standards

Observe the following conditions ( (1) and (2) ) to make the system to conform to UL508C (File No. E164620).

- Use Minas driver in environment of Pollution Degree 1 or 2 prescribed in IEC-60664-1. (e.g. Install in the control panel with IP54 protective structure)
- Connect the UL recognized (UL Listed, ) marked) circuit breaker or UL recognized (UL Listed, ) marked) fuse between the power supply and noise filter.

# Motor Specifications and Ratings 100V MUMA

## 50W to 200W Low inertia Small drives

		AC100V			
Motor model		MUMA	5AZP1□	011P1□	021P1□
Applicable driver	Model No.	MKDET1105P	MKDET1110P	MLDET2110P	
	Frame symbol	Frame K		Frame L	
Power supply capacity (kVA)		0.3	0.4	0.5	
Rated output (W)		50	100	200	
Rated torque (N·m)		0.16	0.32	0.64	
Momentary Max. peak torque (N·m)		0.48	0.95	1.91	
Rated current (Arms)		1.0	1.6	2.5	
Max. current (Ao-p)		4.3	6.9	11.7	
Regenerative brake frequency (times/min) Note)1	Without option	No limit Note)2			
	DV0P2890	No limit Note)2			
Rated rotational speed (r/min)		3000			
Max. rotational speed (r/min)		5000			
Moment of inertia of rotor (× 10 <sup>-4</sup> kg·m <sup>2</sup> )	Without brake	0.021	0.032	0.10	
	With brake	0.026	0.036	0.13	
Recommended moment of inertia ratio of the load and the rotor Note)3		Smaller than 30 times			
Rotary encoder specifications		2500P/r Incremental			
	Resolution per single turn	10000			
Protective enclosure rating		IP65 (except shaft through hole and cable end connector)			
Environment	Ambient temperature	0 to 40°C (free from freezing, Storage : -20 to + 80°C)			
	Ambient humidity	85%RH or lower (free from condensing)			
	Installation location	Indoors (no direct sunlight), free from corrosive gas, inflammable gas, oil mist and dust			
	Altitude	1000m or lower			
	Vibration resistance	49m/s <sup>2</sup> or less			
Mass (kg), ( ) represents holding brake type		0.4 (0.6)	0.5 (0.7)	0.96 (1.36)	

Brake specifications (This brake will be released when it is energized. Do not use this for braking the motor in motion.)		
Static friction torque (N · m)	0.29	1.27
Engaging time (ms)	25	50
Releasing time (ms) Note)4	20 (30)	15 (100)
Exciting current (DC) (A)	0.26	0.36
Releasing voltage	DC 1V or more	
Exciting voltage	DC 24V±10%	

Permissible load			
During assembly	Radial load P-direction (N)	147	392
	Thrust load A-direction (N)	88	147
	Thrust load B-direction (N)	117	196
During operation	Radial load P-direction (N)	68	245
	Thrust load A-direction (N)	58	98
	Thrust load B-direction (N)	58	98

For motor dimensions, refer to page E15, and for the diver, refer to page E23.

## Model designation MUMA series, 50W to 200W

e.g.)

**M U M A 5 A Z P 1 S**

Symbol	Type
MUMA	Ultra low inertia (50W~200W)

Symbol	Rated output
5A	50W
01	100W
02	200W

Symbol	Specifications
1	100V
Z	100/200V (50W only)

Design order  
1 : Standard

Motor structure

Symbol	Shaft		Holding brake		Oil seal	
	Round	Key-way, center tap	without	with	without	with*
S		●	●		●	
T		●		●	●	

\*Motor with oil seal is manufactured by order.  
Round shaft is manufactured by order.

Rotary encoder specifications

Symbol	Format	Pulse counts	Resolution	Wires
P	Incremental	2500P/r	10000	5

## Torque characteristics at AC100V of power voltage

(Dotted line represents the torque at 10% less supply voltage.)

MUMA5AZP1□

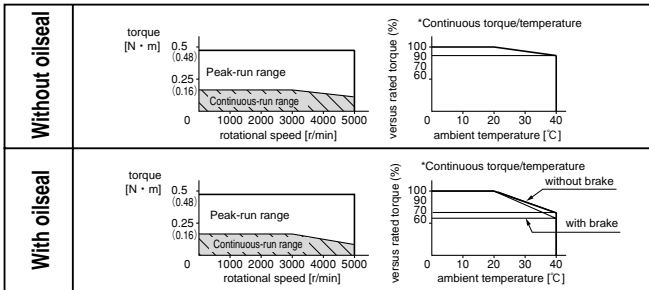

MUMA011P1□

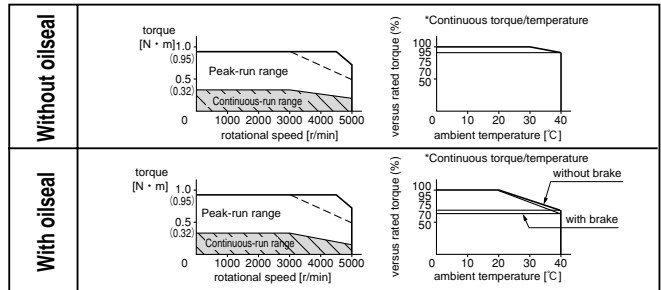

MUMA021P1□

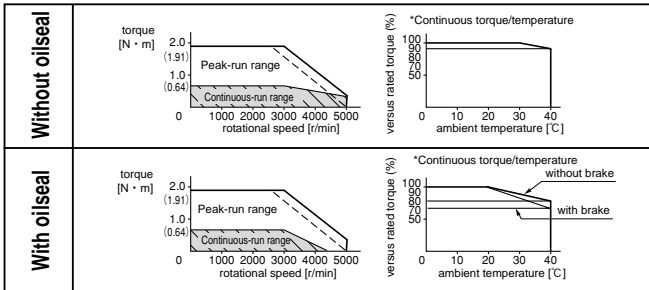

\*When you lower the torque limit setup (Pr5E and 5F), running range at high speed might be lowered as well.

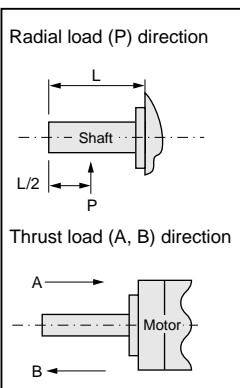
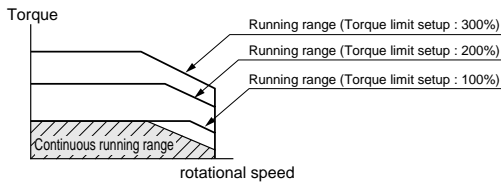

Note) 1. Regenerative brake frequency represents the frequency of the motor's stops from the rated speed with deceleration without load.

- If the load is connected, frequency will be defined as  $1/(m+1)$ , where  $m$ =load moment of inertia/rotor moment of inertia.
  - When the motor speed exceeds the rated speed, regenerative brake frequency is in inverse proportion to the square of (running speed/rated speed).
  - Power supply voltage is AC115V (at 100V of the main voltage).  
If the supply voltage fluctuates, frequency is in inverse proportion to the square of (Running supply voltage/115) relative to the value in the table.
  - When regeneration occurs continuously such cases as running speed frequently changes or vertical feeding, consult us or a dealer.
2. If the effective torque is within the rated torque, there is no limit in generative brake.
  3. Consult us or a dealer if the load moment of inertia exceeds the specified value.
  4. Specified releasing time is obtained with the use of surge absorber for brake (Z15D151 by Ishizuka Electronic or equivalent).  
( ) represents the actually measured value using a diode (200V, 1A or equivalent)



## Model designation MUMA series, 50W to 400W

e.g.)

M U M A 5 A Z P 1 S

Symbol	Type
MUMA	Ultra low inertia (50W to 400W)

Motor rated output

Symbol	Rated output
5A	50W
01	100W
02	200W
04	400W

Voltage specifications

Symbol	Specifications
2	200V
Z	100/200V (50W only)

Design order  
1 : Standard

### Motor structure

Symbol	Shaft		Holding brake		Oil seal	
	Round	Key-way, center tap	without	with	without	with*
S		●	●		●	
T		●		●	●	

\*Motor with oil seal is manufactured by order.  
Round shaft is manufactured by order.

### Rotary encoder specifications

Symbol	Format	Pulse counts	Resolution	Wires
P	Incremental	2500P/r	10000	5

## Torque characteristics at AC200V of power voltage

(Dotted line represents the torque at 10% less supply voltage.)

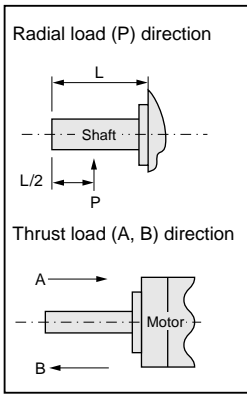
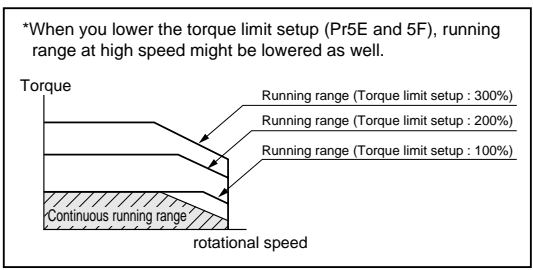
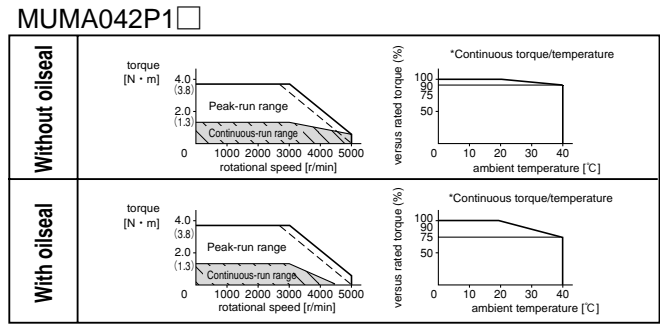
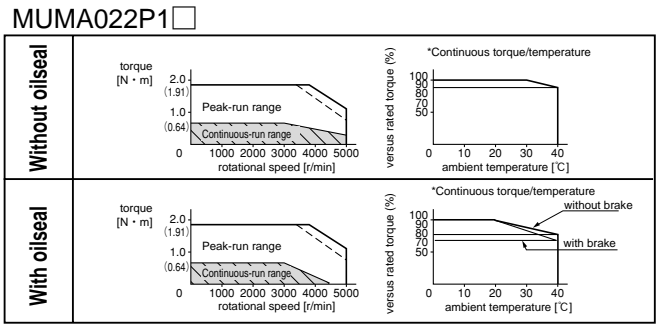
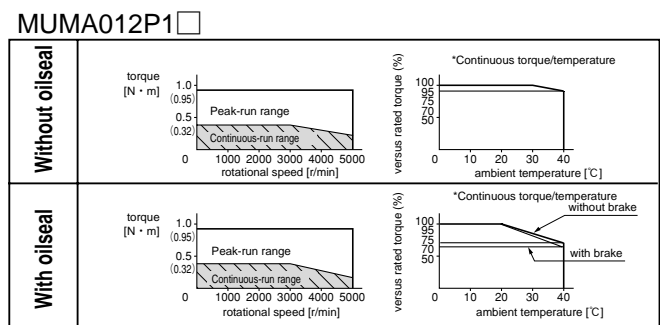
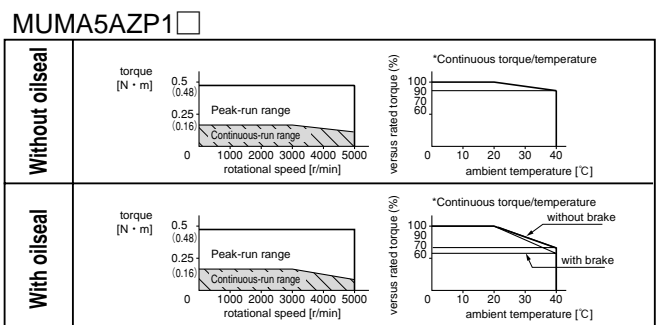

- Note) 1. Regenerative brake frequency represents the frequency of the motor's stops from the rated speed with deceleration without load.
- If the load is connected, frequency will be defined as  $1/(m+1)$ , where  $m$ =load moment of inertia/rotor moment of inertia.
  - When the motor speed exceeds the rated speed, regenerative brake frequency is in inverse proportion to the square of (running speed/rated speed).
  - Power supply voltage is AC240V (at 200V of the main voltage).  
If the supply voltage fluctuates, frequency is in inverse proportion to the square of (Running supply voltage/240) relative to the value in the table.
  - When regeneration occurs continuously such cases as running speed frequently changes or vertical feeding, consult us or a dealer.
2. If the effective torque is within the rated torque, there is no limit in generative brake.
  3. Consult us or a dealer if the load moment of inertia exceeds the specified value.
  4. Specified releasing time is obtained with the use of surge absorber for brake (Z15D151 by Ishizuka Electronic or equivalent).  
( ) represents the actually measured value using a diode (200V, 1A or equivalent)

# Motor Dimensions

## MUMA 50W to 400W

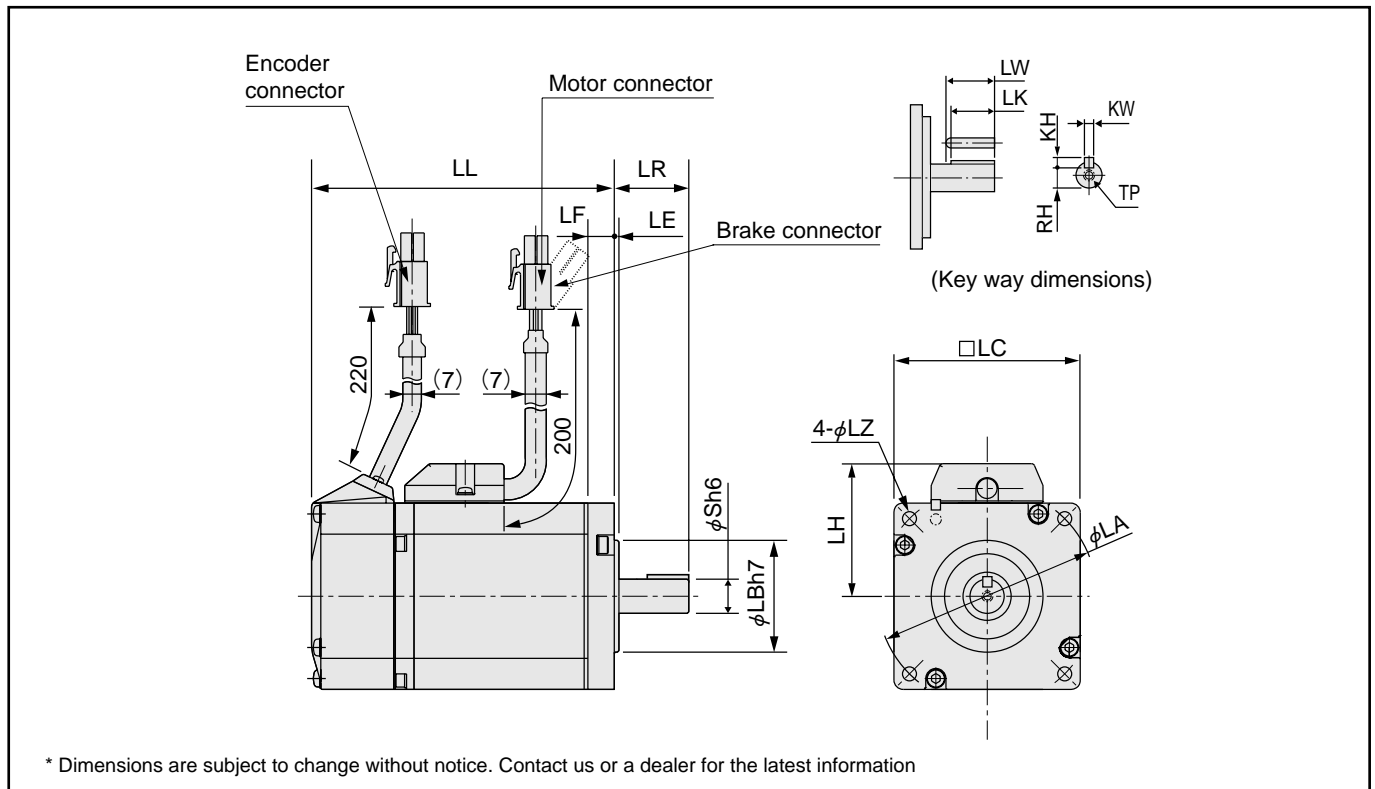

		<b>MUMA series</b> (Ultra low inertia)			
Motor output		50W	100W	200W	400W
Motor model	MUMA	5A□P1□	01□P1□	02□P1□	04□P1□
Rotary encoder specifications		2500P/r Incremental	2500P/r Incremental	2500P/r Incremental	2500P/r Incremental
LL	Without brake	75.5	92.5	96	123.5
	With brake	107	124	129	156.5
LR		24	24	30	30
S		8	8	11	14
LA		48	48	70	70
LB		22	22	50	50
LC		42	42	60	60
LE		2	2	3	3
LF		7	7	7	7
LH		34	34	43	43
LZ		3.4	3.4	4.5	4.5
Key way	LW	14	14	20	25
	LK	12.5	12.5	18	22.5
	KW	3h9	3h9	4h9	5h9
	KH	3	3	4	5
	RH	6.2	6.2	8.5	11
	TP	M3 X 6 (depth)	M3 X 6 (depth)	M4 X 8 (depth)	M5 X 10 (depth)
Mass (kg)	Without brake	0.40	0.50	0.96	1.5
	With brake	0.60	0.70	1.36	1.9
Connector/Plug specifications		refer to Options, pages E26, 27.			

\* Cautions : Reduce the moment of inertia ratio if high speed response operation is required.  
Read the Instruction Manual carefully and understand all precautions and remarks before using the products.

# MINAS E Series Motors with Gear Reducer

## Motor types with gear reducer

Reduction ratio	Motor output (W)			Type of reducer
	100	200	400	
1/ 5	●	●	●	For high precision
1/ 9	●	●	●	
1/25	●	●	●	

Efficiency of the gear reducer shows the following inclination in relation to output torque and rotational speed.

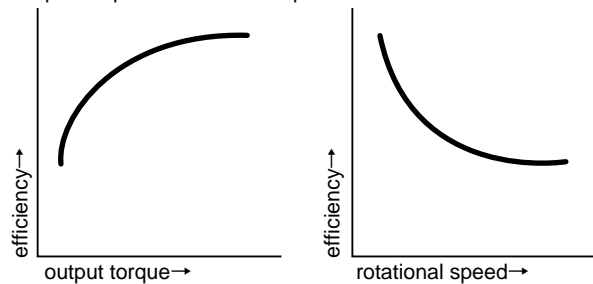

## Specifications of motor with gear reducer

Motor type		MUMA
Gear reducer	Backlash	3 minutes or smaller (initial value) at output shaft of the reducer
	Composition of gear	Planetary gear
	Gear efficiency	65% to 85%
	Rotational direction at output shaft (of reducer)	Same direction as the motor output shaft
	Composition of gear	Planetary gear
	Mounting method	Flange mounting
	Permissible moment of inertia of the load (conversion to the motor shaft)	10 times or smaller than rotor moment of inertia of the motor
Environment	Protective structure	IP44 (at gear reducer)
	Ambient temperature	0 to 40°C
	Ambient humidity	85%RH (free from condensation) or less
	Vibration resistance	49m/s <sup>2</sup> or less (at motor frame)
	Impact resistance	98m/s <sup>2</sup> or less

# Ratings and Specifications of Motor with Gear Reducer

## Model No. designation

e.g.) M U M A 0 1 1 P 3 1 N

Symbol	Type
MUMA	Low inertia (100-400W)

Motor rated output	Symbol	Rated output
	01	100W
	02	200W
	04	400W

Voltage specifications	
Symbol	Specifications
1	100V
2	200V

Symbol	Format	Pulse counts	Pulse counts	Wire
P	Incremental	2500P/r	10000	5

Motor types with gear reducer					
Symbol	Reduction ratio	Motor output			Type of reducer
		100	200	400	
1N	1/5	●	●	●	For High precision
2N	1/9	●	●	●	
4N	1/25	●	●	●	

Motor structure			
Symbol	Shaft	Holding brake	
	Key-way	w/without	w/with
3	●	●	
4	●		●

## Table of Specifications

Model	MUMA with gear reducer												
	Motor Output	Reduction ratio	Output	Rated speed	Max. speed	Rated torque	Peak max. torque	Moment of inertia (motor + reducer/converted to motor shaft)		Mass		Permissible radial load	Permissible thrust load
								w/o brake	w/ brake	w/o brake	w/ brake		
	(W)	(W)	(r/min)	(r/min)	(N·m)	(N·m)	J( $\times 10^{-4}$ kg·m <sup>2</sup> )		(kg)		(N)	(N)	
MUMA01□P□1N	100	1/5	75	600	1000	1.18	3.72	0.072	0.076	1.05	1.25	490	245
MUMA01□P□2N		1/9	80	333	555	2.25	6.86	0.0663	0.0703	1.05	1.25	588	294
MUMA01□P□4N		1/25	80	120	200	6.27	19.0	0.0645	0.0685	2.20	2.40	1670	833
MUMA02□P□1N	200	1/5	170	600	1000	2.65	8.04	0.218	0.248	1.68	2.08	490	245
MUMA02□P□2N		1/9	132	333	555	3.72	11.3	0.368	0.398	2.66	3.06	1180	588
MUMA02□P□4N		1/25	140	120	200	11.1	33.3	0.388	0.418	2.66	3.06	1670	833
MUMA04□P□1N	400	1/5	340	600	1000	5.39	16.2	0.533	0.563	3.2	3.6	980	490
MUMA04□P□2N		1/9	332	333	555	9.51	28.5	0.438	0.468	3.2	3.6	1180	588
MUMA04□P□4N		1/25	332	120	200	26.4	79.2	0.470	0.500	4.7	5.1	2060	1030

For dimensions, refer to page, E21

## The Combination of the Driver and the Motor

Combination with driver		100V		200V		
Encoder	Motor output	Single phase, 100V		3-phase, 200V		Single phase, 200V
		Part No. of motor with reducer	Part No. of driver	Part No. of motor with reducer	Part No. of driver	Part No. of driver
2500P/r Incremental	100W	MUMA011P□□N	MKDET1110P	MUMA012P□□N	MKDET1505P	MKDET1505P
	200W	MUMA021P□□N	MLDET2110P	MUMA022P□□N	MKDET1310P	MLDET2210P
	400W	—	—	MUMA042P□□N	MLDET2510P	MLDET2510P
				MLDET2310P		

For dimensions, refer to page E23

## Torque Characteristics of Motor with Gear Reducer

■ For high precision

Supply voltage to driver	Reduction ratio		1/5	1/9	1/25	
	Motor output					
100V	100W		<p>MUMA011P□1N</p>	<p>MUMA011P□2N</p>	<p>MUMA011P□4N</p>	
		200W	<p>MUMA021P□1N</p>	<p>MUMA021P□2N</p>	<p>MUMA021P□4N</p>	
	200V	100W		<p>MUMA012P□1N</p>	<p>MUMA012P□2N</p>	<p>MUMA012P□4N</p>
			200W	<p>MUMA022P□1N</p>	<p>MUMA022P□2N</p>	<p>MUMA022P□4N</p>
400W	400W		<p>MUMA042P□1N</p>	<p>MUMA042P□2N</p>	<p>MUMA042P□4N</p>	

Dotted line represents the torque at 10% less supply voltage.

# Dimensions of Motor with Gear Reducer

## ■ MUMA series with gear reducer

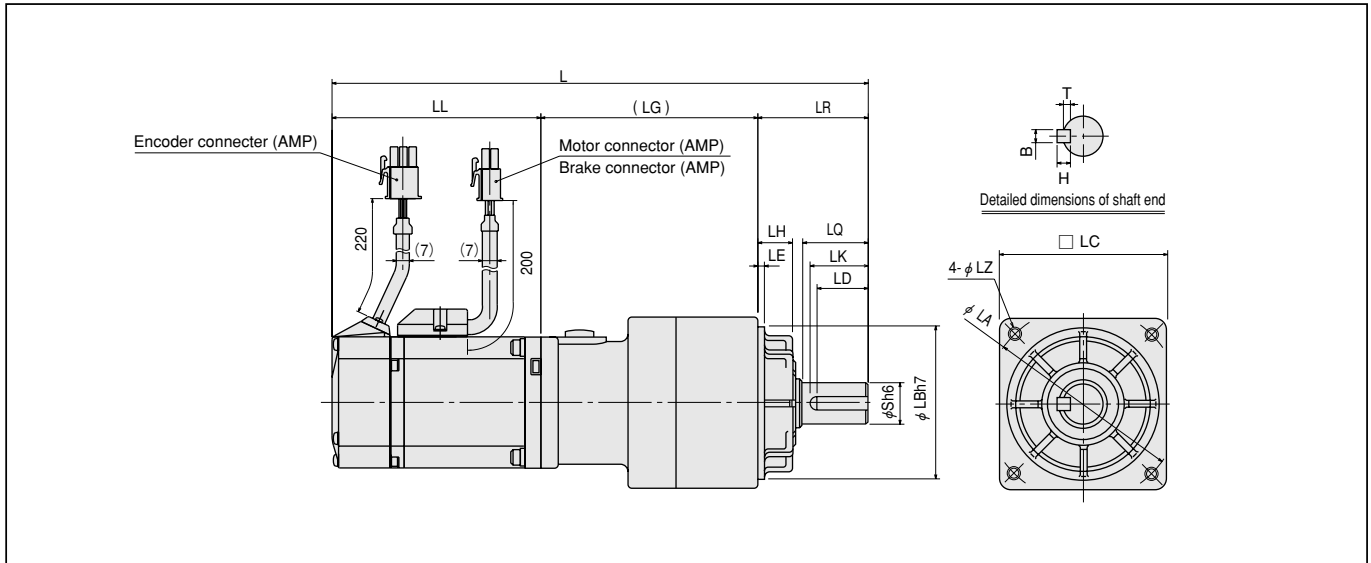

## ■ 2500P/r encoder

Model	Motor output	Reduction ratio	L	LL	LR	LQ	LC	LB	LA	S	LH	LZ	LK	(LG)	LE	Key way (BxHxD)	T		
MUMA01□P□1N	100W	1 / 5	192	92.5	32	20	52	50	60	12	10	M5 (Depth : 12)	18	67.5	3	4X4X16	2.5		
MUMA01□P□2N			223.5	124															
MUMA01□P□4N		1 / 9	192	92.5															
			223.5	124															
MUMA02□P□1N	200W	1 / 5	234.5	92.5	50	30	78	70	90	19	17	M6 (Depth : 20)	26	92		3	6X6X22	3.5	
			MUMA02□P□2N	266															124
		MUMA02□P□4N	1 / 9	200.5															96
				233.5															129
MUMA04□P□1N	400W	1 / 5	235.5	96	50	30	78	70	90	19	17	M6 (Depth : 20)	26	89.5	3		6X6X22	3.5	
			MUMA04□P□2N	268.5															129
		MUMA04□P□4N	1 / 9	246															96
				279															129
MUMA04□P□1N	400W	1 / 5	263	123.5	61	40	98	90	115	24	18	M8 (Depth : 20)	35	104		3	8X7X30	4	
			MUMA04□P□2N	296															156.5
		MUMA04□P□4N	1 / 9	263															123.5
				296															156.5
MUMA04□P□4N	1/25	288.5	123.5	61	40	98	90	115	24	18	M8 (Depth : 20)	35	104	5	8X7X30		4		
		321.5	156.5																

Upper column : without brake   
 Lower column : with brake

## Common Specifications of Driver

Basic Specifications	Input power	Single phase, 100V	Single phase, 100-115V +10% -15% 50/60Hz		
		Single phase, 200V	Single phase, 200-240V +10% -15% 50/60Hz		
		3-phase, 200V	3-phase, 200-240V +10% -15% 50/60Hz		
	Environment	Temperature	Operating : 0 to 55°C, Storage : -20 to +80°C		
		Humidity	Both operating and storage : 90%RH or less (free from condensation)		
		Altitude	1000m or lower		
		Vibration	5.88m/s <sup>2</sup> or less, 10 to 60Hz (No continuous use at resonance frequency)		
	Control method		IGBT PWM Sinusoidal wave drive		
	Encoder feedback		2500P/r (10000 resolution) incremental encoder		
	Control signal	Input	7 inputs (1) Servo-ON, (2) Alarm clear and other inputs vary depending on the control mode.		
		Output	4 outputs (1) Servo alarm, (2) Alarm, (3) Release signal of external brake and other outputs vary depending on the control mode.		
	Pulse signal	Input	2 inputs Supports both line driver I/F and open collector I/F with photo-coupler input.		
		Output	4 outputs Feed out the encoder pulse (A, B and Z-phase) in line driver. Z-phase pulse is also fed out in open collector.		
	Communication function	RS232	1 : 1 communication to a host with RS232 interface is enabled.		
	Display LED		(1) Status LED (STATUS), (2) Alarm code LED (ALM-CODE)		
	Regeneration		No built-in regenerative resistor (external resistor only)		
	Dynamic brake		Built-in		
Control mode		3 modes of (1) High-speed position control, (2) Internal velocity control and (3) High-functionality positioning control are selectable with parameter.			
Functions	Position control	Control input	① CW over-travel inhibition, ② CCW over-travel inhibition, ③ Deviation counter clear, ④ Gain switching, ⑤ Electronic gear switching		
		Control output	(1) Positioning complete (In-position)		
	Pulse input	Max. command pulse frequency	Line driver : 500kpps, Open collector : 200kpps		
		Type of input pulse train	Differential input. Selectable with parameter, ((1) CW/CCW, (2) A and B-phase, (3) Command and Direction)		
		Electronic gear (Division/Multiplication of command pulse)	Setup of electronic gear ratio Setup range of (1-10000 X 2(0-17))/(1-10000)		
		Smoothing filter	Primary delay filter or FIR type filter is selectable to the command input.		
	Internal speed control	Control input	① CW over-travel inhibition, ② CCW over-travel inhibition, ③ Selection1 of internal command speed, ④ Selection 2 of internal command speed, ⑤ Speed zero clamp		
		Control output	(1) Speed arrival (at-speed)		
		Internal speed command	Internal 4-speed is selectable with control input.		
		Soft-start/down function	Individual setup of acceleration and deceleration is enabled, with 0 to 10s/1000r/min. Sigmoid acceleration/deceleration is also enabled.		
		Zero-speed clamp	0-clamp of internal speed command with speed zero clamp input is enabled.		
	Common	Auto-gain tuning	Real-time	Estimates the load inertia in real-time in actual operation and sets up the gain automatically corresponding to the machine stiffness. Useable at (1) High-response position control, (2) Internal speed control and (3) High-functionality position control.	
			Normal mode	Estimates the load inertia with an action command inside of the driver, and sets up the gain automatically corresponding to setup of the machine stiffness. Useable at (1) High-response position control, (2) Internal speed control and (3) High-functionality position control.	
		Masking of unnecessary input		Masking of the following input signal is enabled. (1) Over-travel inhibition, (2) Speed zero clamp (3) Torque limit switching	
		Division of encoder feedback pulse		1P/r to 2500P/r (encoder pulses count is the max.).	
		Protective function	Hardware error	Over-voltage, under-voltage, over-speed over-load, over-heat, over-current and encoder error etc.	
			Software error	Excess position deviation, command pulse division error, EEPROM error etc.	
Traceability of alarm data		Traceable up to past 14 alarms including the present one.			
Damping control function		Manual setup with parameter			
Setup	Manual	Console			
	Setup support software	PANATERM <sup>®</sup> (Supporting OS : Windows98, Windows ME, Windows2000, and WindowsXP)			

# Standard Wiring Example of Main Circuit

## ■ 3-Phase, 200V

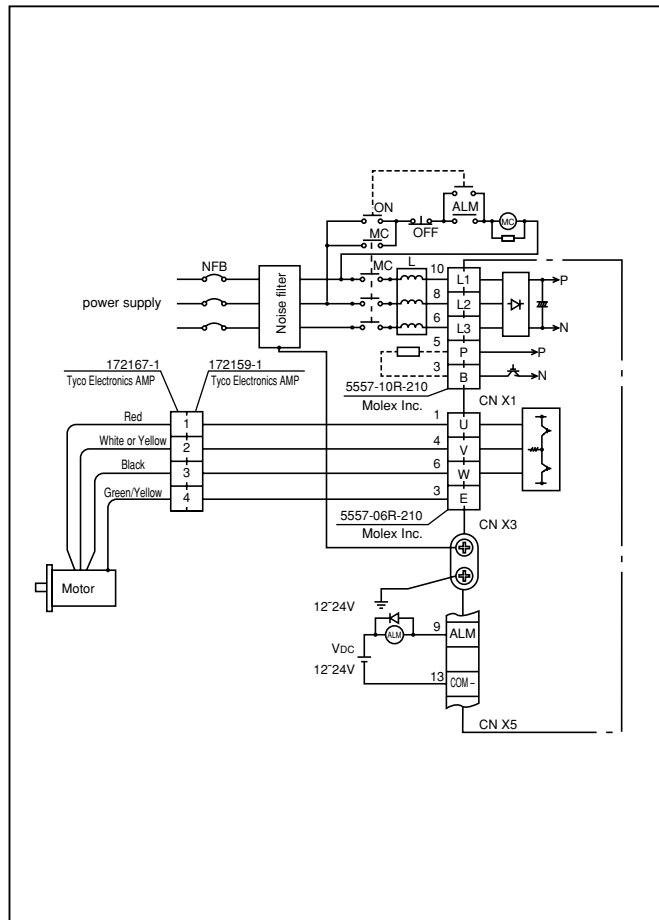

## ■ Single Phase, 100V / 200V

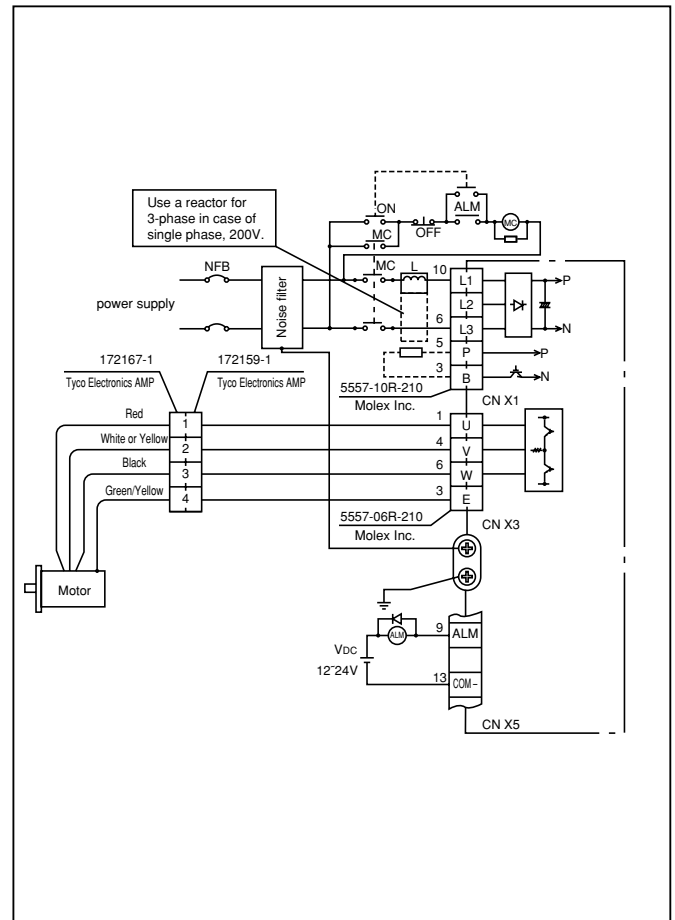

# Encoder Wiring Diagram

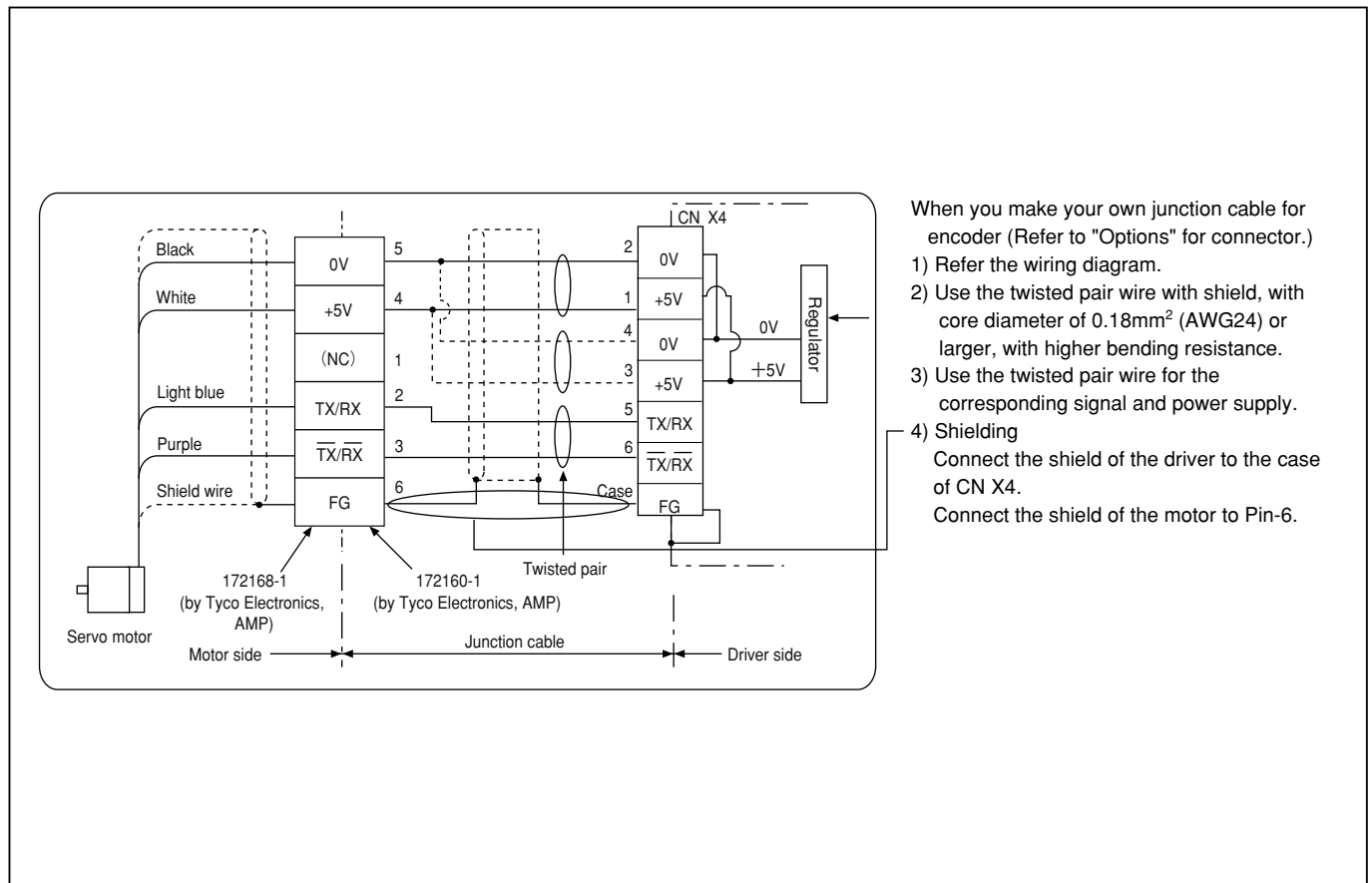

### Control Circuit Standard Wiring Example

#### ■ CN X 5 Wiring Example at Position Control Mode

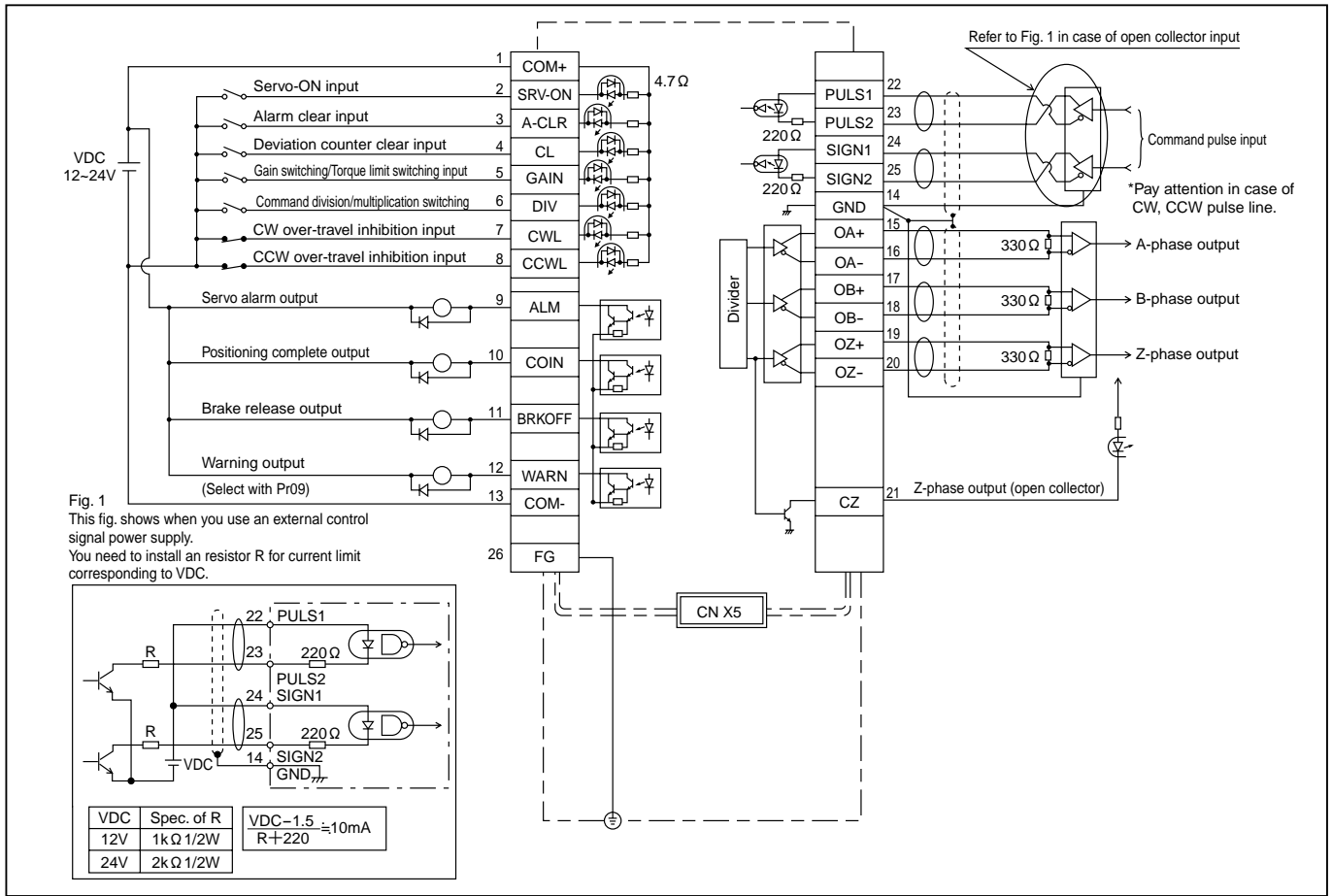

#### ■ CN X 5 Wiring Example at Internal Velocity Control Mode

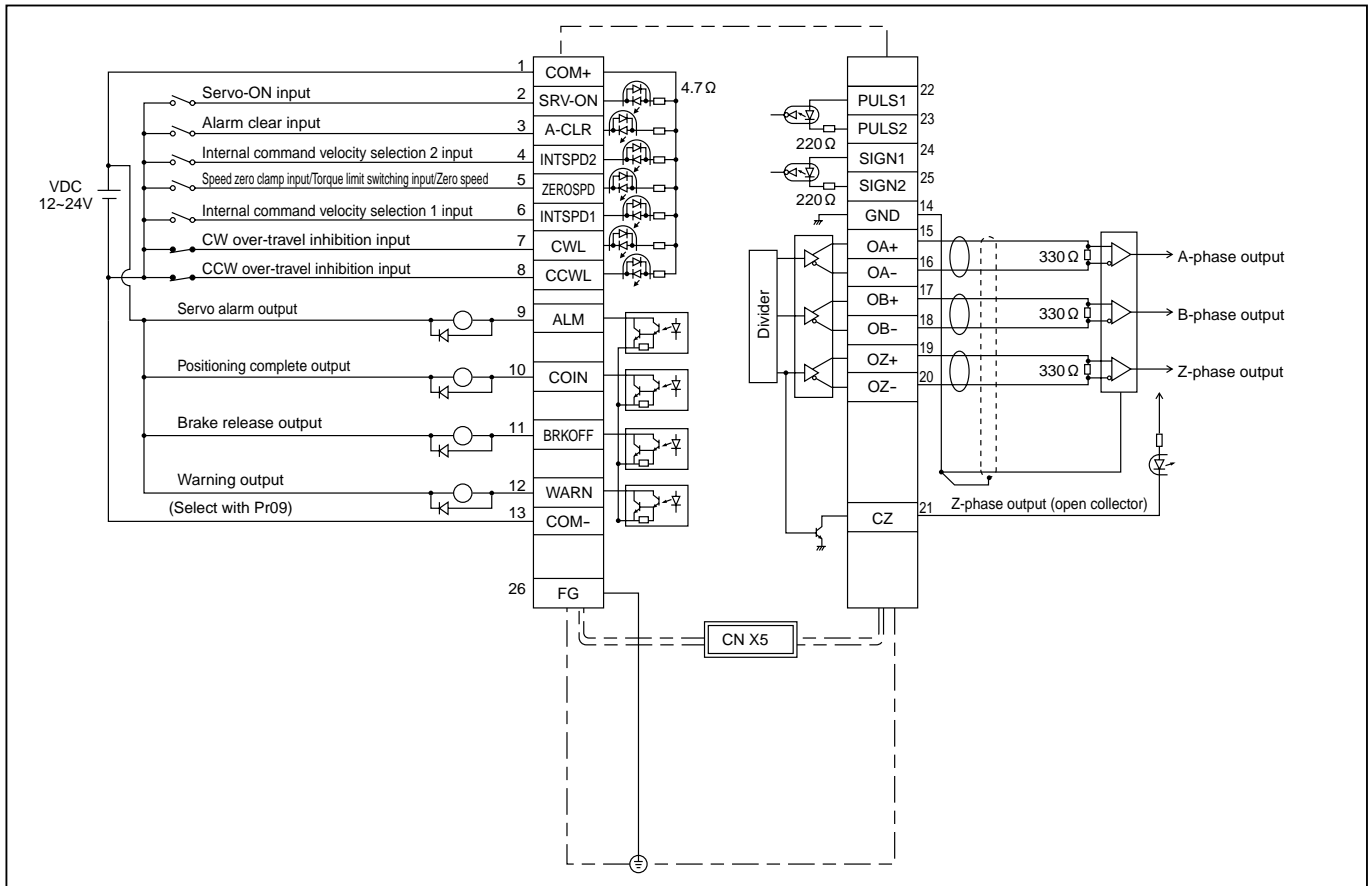

# Dimensions

## Frame K

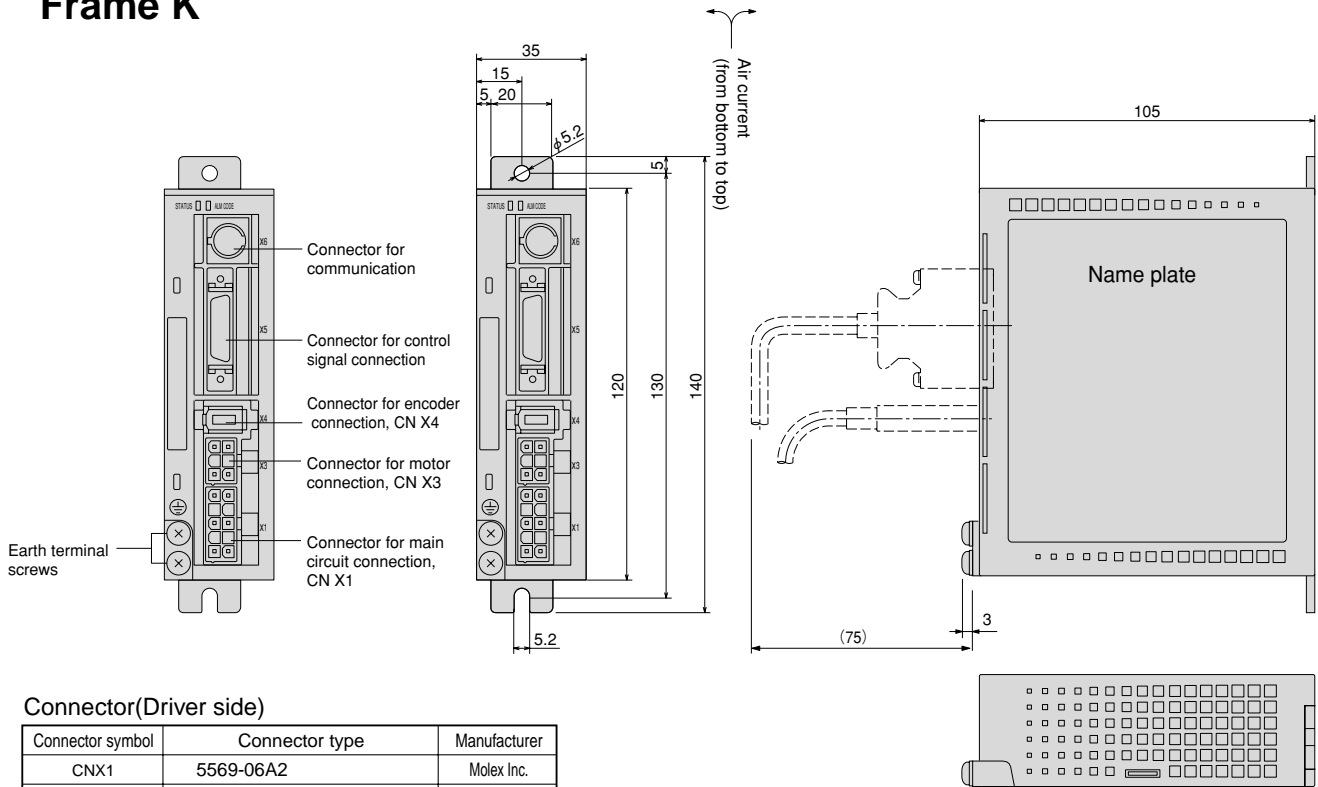

Mass : 0.35kg

## Frame L

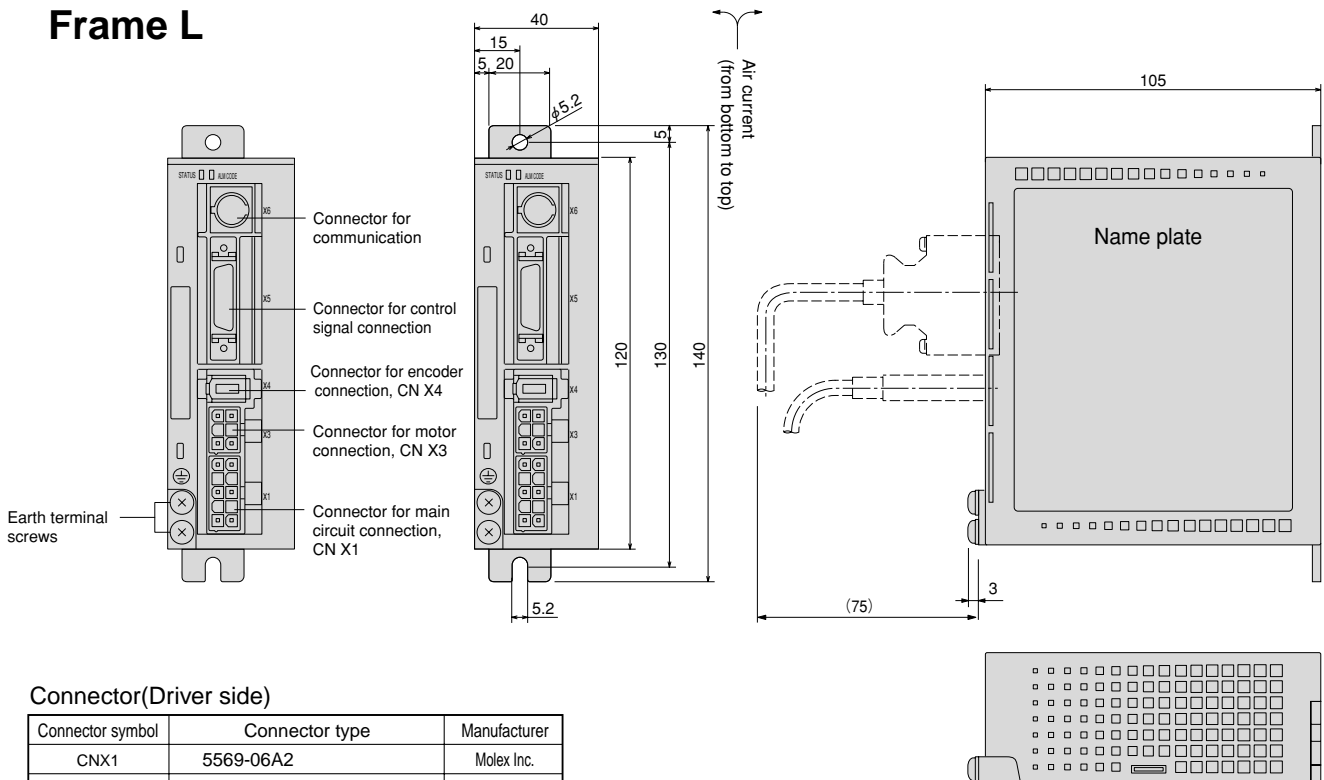

Mass : 0.40kg

## Options

### Cable part No. designation

#### Encoder cable

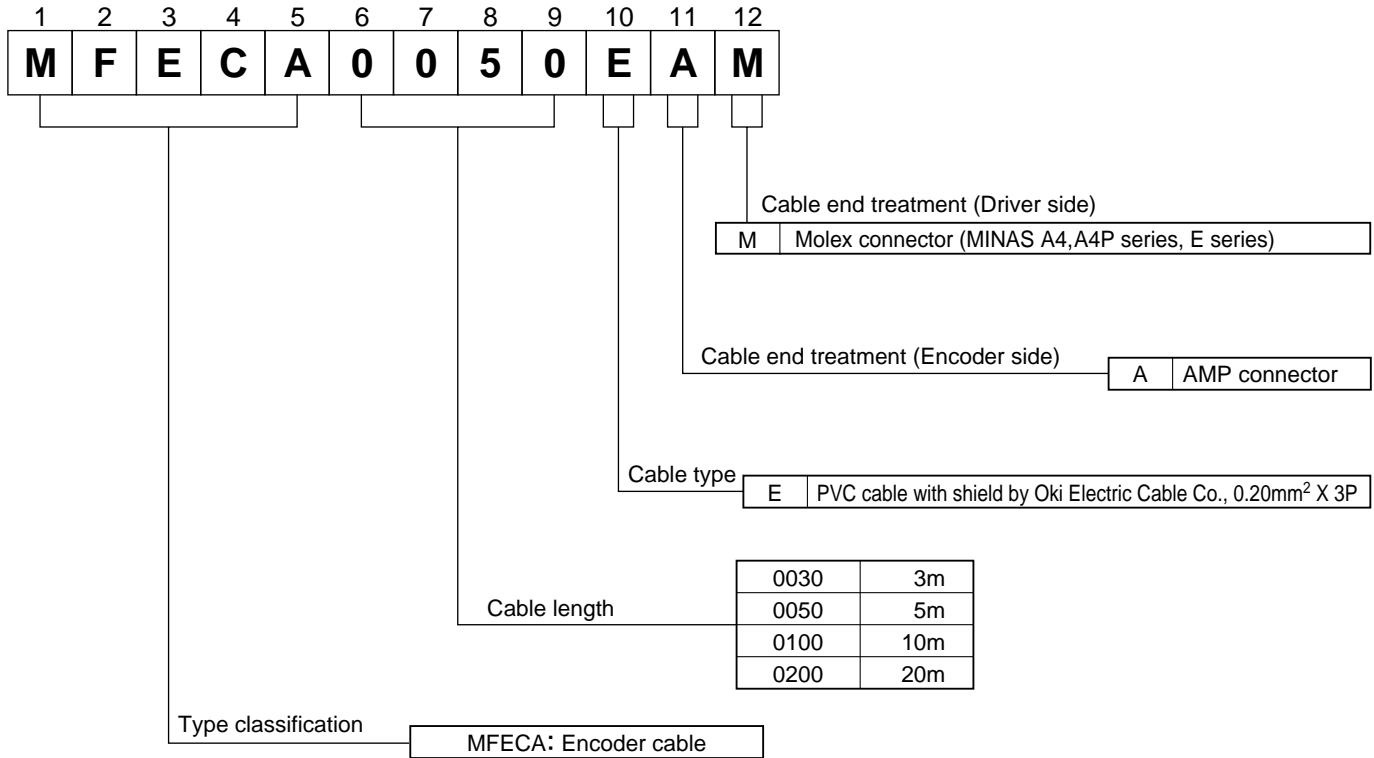

#### Motor cable

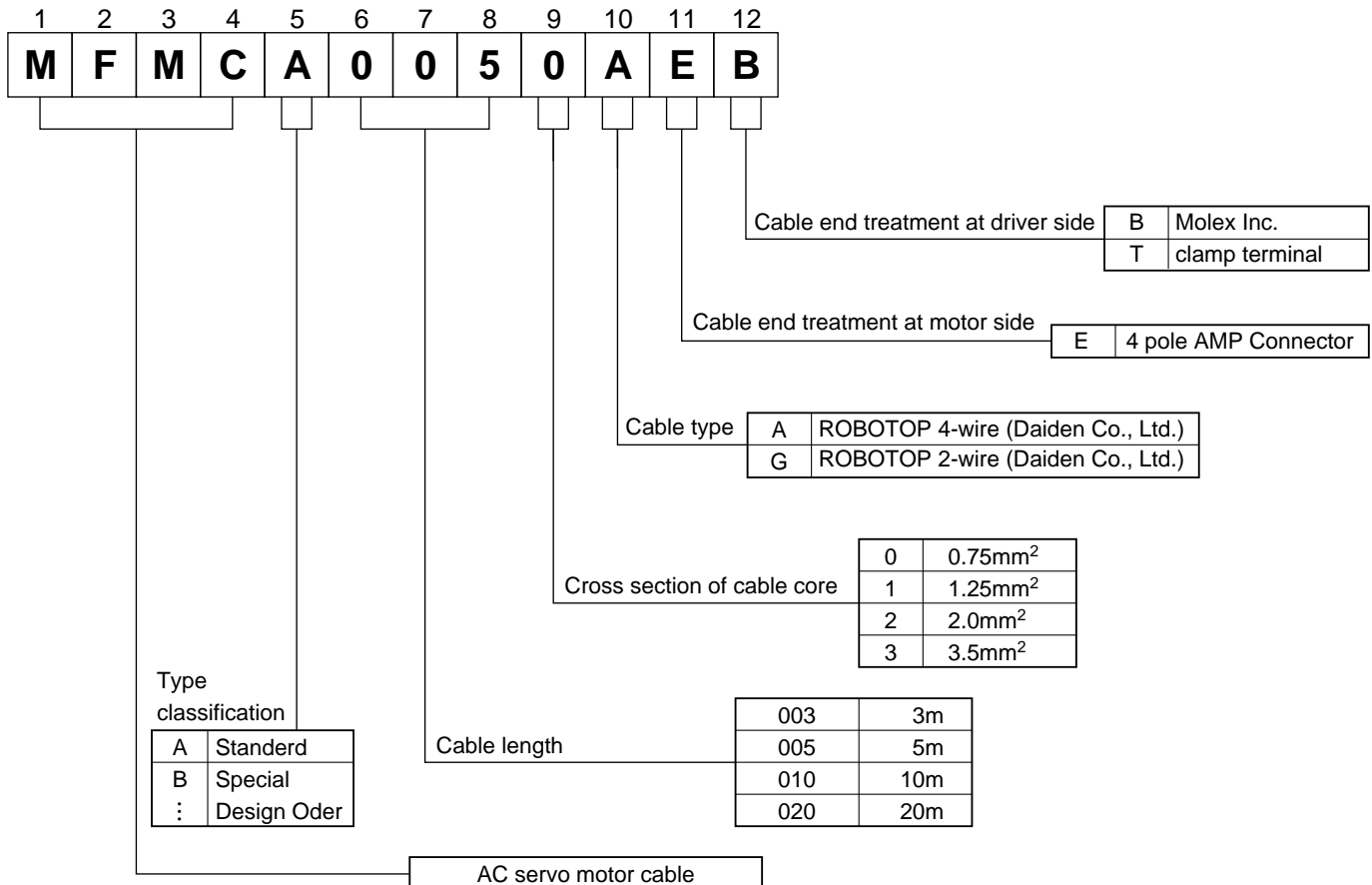

MINAS E Driver / Options

# Options

## Cable set DV0P37300 (3m)

- 1) Interface cable : DV0P0800
- 2) Encoder cable (3m) : MFECA0030EAM
- 3) Motor cable (3m) : MFMCA0030AEB
- 4) Connector kit for driver power supply connection : DV0P2870

## Cable set DV0P39200 (5m)

- 1) Interface cable : DV0P0800
- 2) Encoder cable (5m) : MFECA0050EAM
- 3) Motor cable (5m) : MFMCA0050AEB
- 4) Connector kit for driver power supply connection : DV0P2870

## Encoder cable

MFECA0 \* \* 0EAM

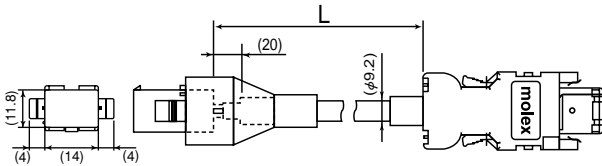

Title	Part No.	Manufacturer
Connector	55100-0600 and 55100-0670	Molex Inc.
	172160-1	
Connector Pin	170365-1	
Cable	0.20mm <sup>2</sup> X3P	Oki Electric Cable

L(m)	Part No.
3	MFECA0030EAM
5	MFECA0050EAM
10	MFECA0100EAM
20	MFECA0200EAM

## Motor cable (Robotop<sup>®</sup> 105°C · 600V · DP)

Robotop<sup>®</sup> is a trade mark of Daiden Co., Ltd.

MFMCA0 \* \* 0AEB

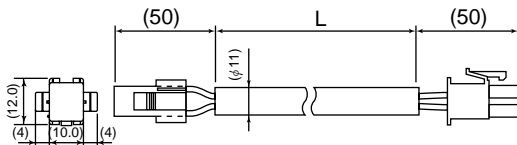

Title	Part No.	Manufacturer
Connector	172159-1	Tyco Electronics AMP
Connector Pin	170362-1,170366-1	
Connector	5557-06R-210	Molex Inc.
Connector Pin	5556T	
Cable	ROBO-TOP 600V 0.75mm <sup>2</sup>	Daiden Co., Ltd.

L(m)	Part No.
3	MFMCA0030AEB
5	MFMCA0050AEB
10	MFMCA0100AEB
20	MFMCA0200AEB

## Brake cable (Robotop<sup>®</sup> 105°C · 600V · DP)

MFMCB0 \* \* 0GET

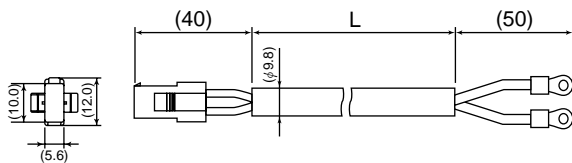

Title	Part No.	Manufacturer
Connector	172157-1	Tyco Electronics AMP
Connector Pin	170362-1,170366-1	
Nylon insulated round fermal	N1.25-M4	JST
Cable	ROBO-TOP 600V 0.75mm <sup>2</sup>	Daiden Co., Ltd.

L(m)	Part No.
3	MFMCB0030GET
5	MFMCB0050GET
10	MFMCB0100GET
20	MFMCB0200GET

## Console

1) Part No. : **DVOP4420** Caution) An existing console(DVOP3690) cannot be used for the A4P series.

2) Dimensions

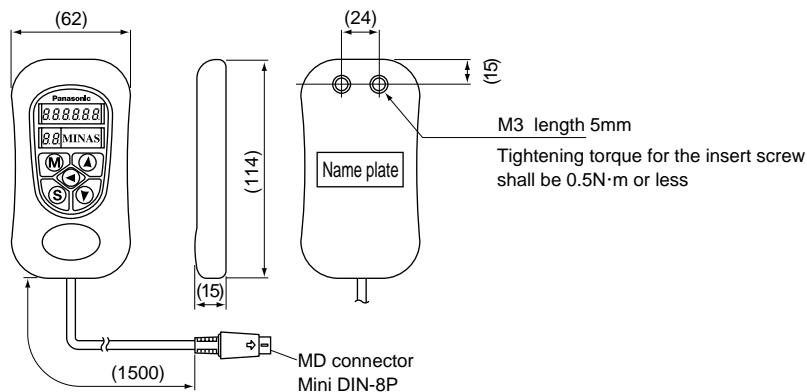

## Connector kit for power supply connection

1) Part No. : **DV0P2870**

2) Parts composition

Title	Part No.	Number	Manufacturer	Note
Connector (10pins)	5557-10R-210	1	Molex Inc.	For connector CN X1 (10 pins)
Connector pin	5556PBTL	6		

3) Pin configuration

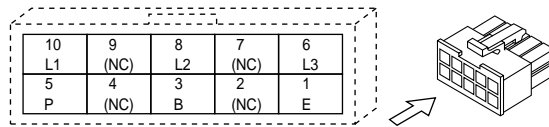

4) Recommended manual crimping tool  
(to be prepared by customer)

Part No.	Cable material
57026-5000	UL1007
57027-5000	UL1015

<Cautions>

1. The above pin disposition shows when viewed from the terminal inserting direction. Make a correct wiring by checking the stamped pin numbers on the connector itself.
2. Refer to page E21 for wiring and connection.
3. Do not connect anything to pins marked "NC".

## Connector kit for motor/encoder connection

1) Part No. : **DV0P3670** ( Incremental ) This option is required when you make your own encoder cable and motor cable.  
 2) Parts composition ( 2500 pulse, 5-wire ) ( Brake cable is required for brake.)

Title	Part No.	Number	Manufacturer	Note
Connector	55100-0600	1	Molex Inc.	For connector, CN X4
Connector (6pins)	172160-1	1	Tyco Electronics AMP	For junction to encoder cable
Connector pin	170365-1	6		
Connector (4pins)	172159-1	1	Tyco Electronics AMP	For junction to motor power cable
Connector pin	170366-1	4		
Connector (6 pins)	5557-06R-210	1	Molex Inc.	For connector, CN X3
Connector pin	5556PBTL	4		

<Remarks>

We may use parts equivalent to the above for shell and connector cover.

3) Pin configuration of connector CN X4 plug

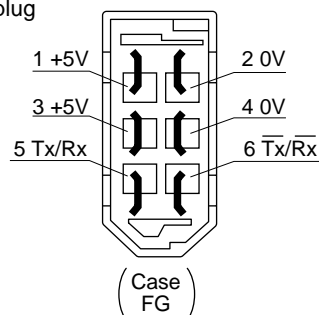

4) Recommended manual crimping tool  
(to be prepared by customer)

Title	Manufacturer's part No.	Manufacturer	Cable material
For encoder cable junction	755330-1	Tyco Electronics AMP	—
For motor power cable junction	755331-1		
For Connector CN X3	57026-5000	Molex Inc.	UL1007
	57027-5000		UL1015

<Remarks>

1. The above pin configuration shows when viewed from the pin-soldering direction. Make a correct wiring by checking the stamped pin numbers on the connector itself.
2. Connect the shield of the wire to the case (FG) without fail.
3. For wiring and connection, refer to page E21.

# Options

## Connector kit for motor/encoder connection

5) Pin configuration of encoder cable junction

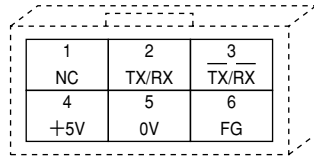

6) Pin configuration of motor power cable junction

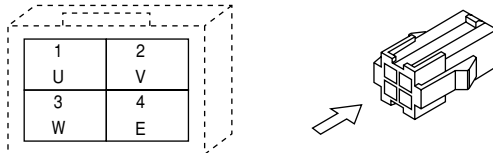

7) Pin configuration of mating connector to CN X3 connector

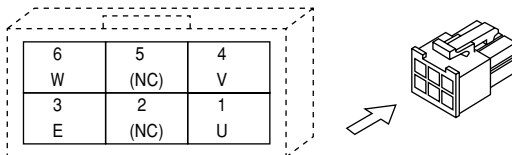

<Cautions>

1. The above pin configuration shows when viewed from the terminal inserting direction. Make a correct wiring by checking the stamped pin numbers on the connector itself.
2. Refer to page E21 for wiring and connection.

## Connector kit for external peripheral equipment

1) Part No. : **DV0P0770**

2) Parts composition

Title	Part No.	Number	Manufacturer	Note
Connector	10126-3000PE	1	Sumitomo 3M	For connector, CN X5 (26 pins)
Connector cover	10326-52A0-008	1		

3) Pin configuration of connector CN X5

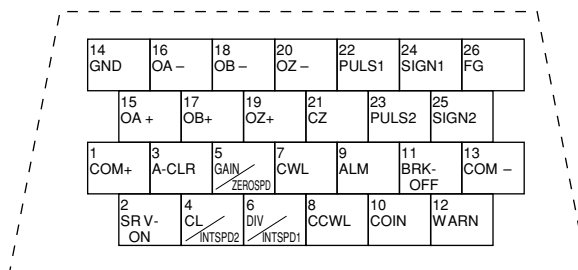

<Cautions>

1. Make a correct wiring by checking the stamped pin numbers on the connector itself.
2. Refer to page E22 for symbols and functions of the above signals.

## Interface cable

1) Part No. : **DV0P0800**

Cable of 2m is connected.

2) Dimensions

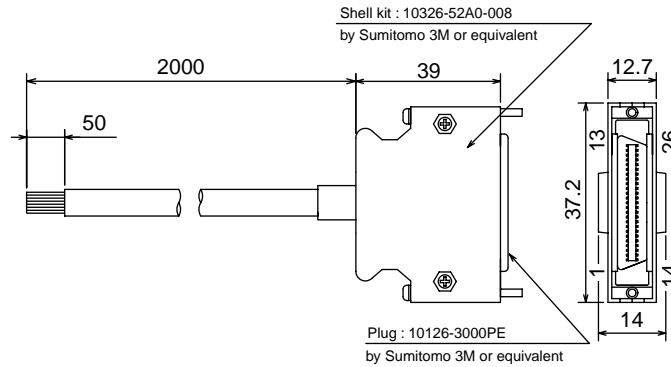

3) Wiring table

Pin No.	Title of signal	Color or cable	Pin No.	Title of signal	Color or cable	Pin No.	Title of signal	Color or cable
1	COM+	Orange (Red 1)	10	COIN	Pink (Black 1)	19	OZ+	Pink (Red 2)
2	SRV-ON	Orange (Black 1)	11	BRK-OFF	Orange (Red 2)	20	OZ-	Pink (Black 2)
3	A-CLR	Gray (Red 1)	12	WARN	Orange (Black 2)	21	CZ	Orange (Red 3)
4	CL/INTSPD2	Gray (Black 1)	13	COM-	Gray (Red 2)	22	PULS1	Gray (Red 3)
5	GAIN/ZEROSPD	White (Red 1)	14	GND	Gray (Black 2)	23	PULS2	Gray (Black 3)
6	DIV/INTSPD1	White (Black 1)	15	OA+	White (Red 2)	24	SIGN1	White (Red 3)
7	CWL	Yellow (Red 1)	16	OA-	White (Black 2)	25	SIGN2	White (Black 3)
8	CCWL	Yellow (Black 1)	17	OB+	Yellow (Red 2)	26	FG	Orange (Black 3)
9	ALM	Pink (red 1)	18	OB-	Yellow (Black 2)			

<Notes>

e. g. of Pin No. designation : Pin No. 1 ...Wire color is orange, and one red dot.  
Pin No. w ...Wire color is orange, and two black dot.

<Remarks>

The shield of this cable is not connected to a connector pin. To connect the shield to FG or GND at the driver side, use a connector kit for external device connection.

## Communication cable

1) Part No. : **DV0P1960**

2) Dimensions

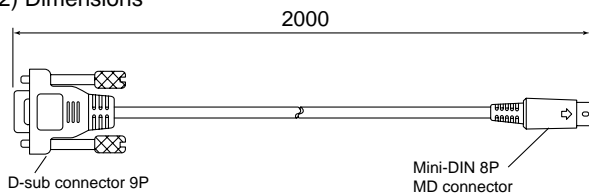

## Setup support software 「PANATERM®」

1) Part No. : **DV0P4460** (for Japanese / English version)

2) Supply media : CD-ROM

<Caution>

For action environment other details, refer to the Instruction Manual of 「PANATERM®」

# Options

## External regenerative resistor

Part No.	Manufacturer's Part No.	Specifications			Note (Input Power of drive)
		Resistance	Rated power	Activation temperature of built-in fuse	
DV0P2890	45M03	50Ω	10W	130±2°C	Single phase, 100V
DV0P2891	45M03	100Ω	10W	130±2°C	Single/3-phase, 200V

Manufactured by Iwaki Musen Kenkyuusho Co., Ltd.

### <Remarks>

Thermal fuse is installed for safety. The thermal fuse may blow due to heat dissipating condition, working temperature, supply voltage or load fluctuation.

Make it sure that the surface temperature of the resistor may not exceed 100°C at the worst running conditions with the machine, which brings large regeneration (such case as high supply voltage, load inertia is large or deceleration time is short)

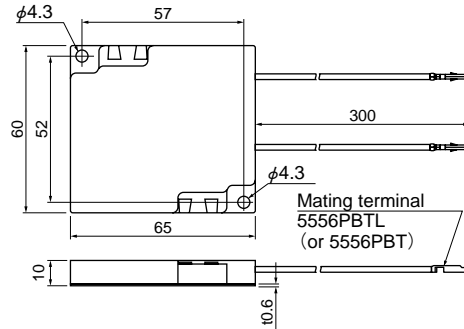

<Caution>  
Regenerative resistor gets very hot.

Take preventive measures for fire and burns.  
Avoid the installation near inflammable objects,  
and easily accessible place by hand.

## Reactor

Frame symbol of driver	Power supply specifications	Rated output	Part No.	Fig.
MKDE	Single phase, 100V	50 - 100W	DV0P227	1
	Single phase, 200V	50 - 100W	DV0P220	2
3-phase, 200V	50 - 200W			
MLDE	Single phase, 100V	200W	DV0P228	1
	Single phase, 200V	200w - 400W	DV0P220	2
	3-phase, 200V	400W		

Fig.1

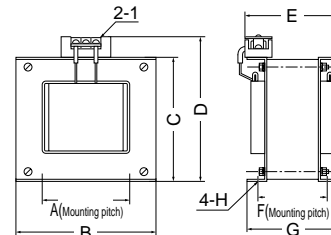

Fig.2

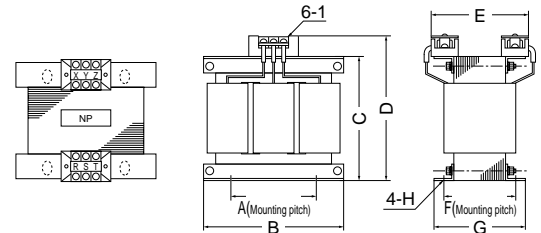

Fig.	Part No.	A	B	C	D	E	F	G	H	I	Inductance (mH)	Rated current (A)
1	DV0P227	55	80	68	90	90	41	55	$\phi 7$	M4	4.02	5
	DV0P228										2	8
2	DV0P220	65	125	83	118	145	70	85	7 (w) X 12 (L)	M4	6.81	3

### • Harmonic restraint on general-purpose inverter and servo driver

On September, 1994, Guidelines for harmonic restraint on heavy consumers who receive power through high voltage system or extra high voltage system and Guidelines for harmonic restraint on household electrical appliances and general-purpose articles established by the Agency for Natural Resources and Energy of the Ministry of Economy, Trade and Industry (the ex-Ministry of International Trade and Industry). According to those guidelines, the Japan Electrical Manufacturers Association (JEMA) have prepared technical documents (procedure to execute harmonic restraint: JEM-TR 198, JEM-TR 199 and JEM-TR 201) and have been requesting the users to understand the restraint and to cooperate with us. On January, 2004, it has been decided to exclude the general-purpose inverter and servo driver from the Guidelines for harmonic restraint on household electrical appliances and general-purpose articles". After that, the Guidelines for harmonic restraint on household electrical appliances and general-purpose articles was abolished on September 6, 2004.

We are pleased to inform you that the procedure to execute the harmonic restraint on general-purpose inverter and servo driver will be modified as follows.

1. All types of the general-purpose inverters and servo drivers used by specific users are under the control of the Guidelines for harmonic restraint on heavy consumers who receive power through high voltage system or extra high voltage system". The users who are required to apply the guidelines must calculate the equivalent capacity and harmonic current according to the guidelines and must take appropriate countermeasures if the harmonic current exceeds a limit value specified in a contract demand. (Refer to JEM-TR 210 and JEM-TR 225.)
2. The Guidelines for harmonic restraint on household electrical appliances and general-purpose articles was abolished on September 6, 2004. However, based on conventional guidelines, JEMA applies the technical documents JEM-TR 226 and JEM-TR 227 to any users who do not fit into the Guidelines for harmonic restraint on heavy consumers who receive power through high voltage system or extra high voltage system from a perspective on enlightenment on general harmonic restraint. The purpose of these guidelines is the execution of harmonic restraint at every device by a user as usual to the utmost extent.

## DIN rail mounting unit

- 1) Part No. : **DV0P3811**  
 2) Dimensions

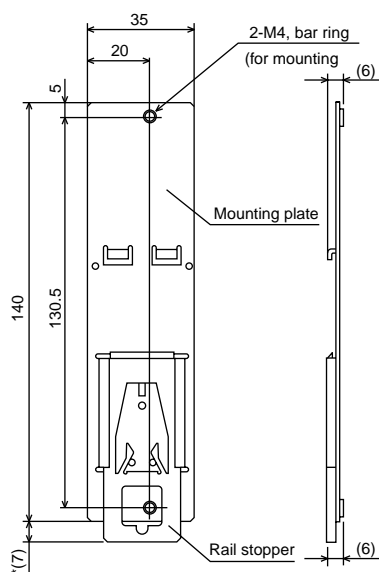

<Notes>  
 2 mounting screws (M4 X L8, Pan head) are attached.  
 Rail stopper can be extended to max. 10mm.

### <Precautions in using options>

Use options correctly after reading operation manuals of the options to better understand the precautions.  
 Take care not to apply excessive stress to each optional part.

## Recommended components

### Surge absorber for motor brake

Motor	Surge absorber for motor brake
MUMA 50W~400W	Z15D151 Ishizuka Electronics Co.

### List of peripheral components

(Reference only)

Peripheral components	Manufacturer	Tel No./Web site
Non-fuse breaker, Magnetic contactor, Surge absorber	Automation Controls Company Matsushita Electric Works, Ltd.	81-6-6908-1131 <a href="http://www.mew.co.jp">http://www.mew.co.jp</a>
Regenerative resistor	Iwaki Musen Kenkyusho Co., Ltd.	81-44-833-4311 <a href="http://www.iwakimusen.co.jp/">http://www.iwakimusen.co.jp/</a>
Surge absorber for holding brake	Ishizuka Electronics Corp.	81-3-3621-2703 <a href="http://www.semitec.co.jp/">http://www.semitec.co.jp/</a>
Noise filter for signal lines	TDK Corp.	81-3-5201-7229 <a href="http://www.tdk.co.jp/">http://www.tdk.co.jp/</a>
Surge absorber / Noise filter	Okaya Electric Industries Co. Ltd.	1-3-4544-7030 <a href="http://www.okayatec.co.jp/">http://www.okayatec.co.jp/</a>
Connector	Sumitomo 3M	81-3-5716-7290 <a href="http://www.mmmco.jp">http://www.mmmco.jp</a>
	Tyco Electronics AMP k.k,	81-44-844-8111 <a href="http://www.tycoelectronics.com/japan/amp">http://www.tycoelectronics.com/japan/amp</a>
	Japan Molex Inc.	81-462-65-2313 <a href="http://www.molex.co.jp">http://www.molex.co.jp</a>
Cable	Daiden Co., Ltd.	81-3-5805-5880 <a href="http://www.dyden.co.jp/">http://www.dyden.co.jp/</a>

\* The above list is for reference only. We may change the manufacturer without notice.