



Plug-in type



PC board type

FEATURES

- **Micro-ISO type terminals**
- **Small size:**
20 mm(L)×15 mm(W)×22 mm(H)
.787 inch(L)×.591 inch(L)×.866 inch(H)
- **Wide line-up**
PC board and Plug-in type, Resistor and diode inside type.
24V DC type is also available.
- **Compact and high-capacity 35A load switching**
N.O.: 35A 14V DC, N.C.: 20A 14V DC (Sealed type)
Min. 5×10^4
N.O.: 35A 14V DC, N.C.: 20A 14V DC (Flux-resistant type)
Min. 10^5 *12V DC type

- **Uses international standard ISO terminal arrangement.**
The ISO international standard terminal arrangement is used.

TYPICAL APPLICATIONS

- Fan motor
- Heater
- Head lamp
- Air Compressor
- EPS
- ABS
- Blower fan
- Defogger, etc.

Compliance with RoHS Directive

ORDERING INFORMATION

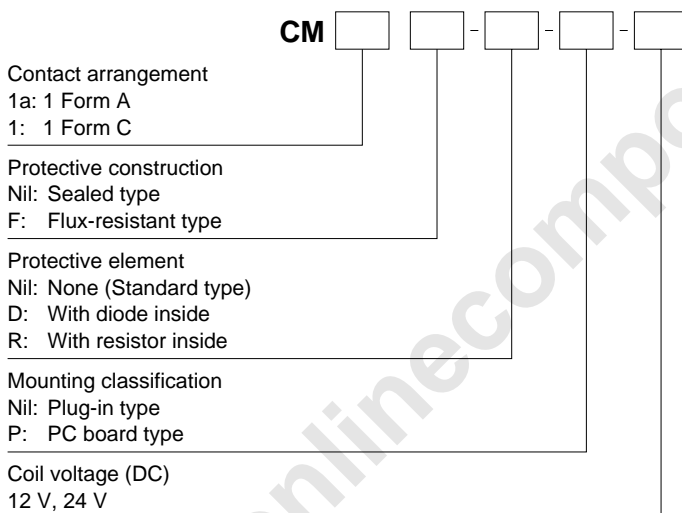

TYPES

Standard type

Contact arrangement	Coil voltage	Plug-in type		PC board type	
		Sealed type	Flux-resistant type	Sealed type	Flux-resistant type
		Part No.	Part No.	Part No.	Part No.
1 Form A	12 V DC	CM1a-12V	CM1aF-12V	—	—
	24 V DC	CM1a-24V	CM1aF-24V	CM1a-P-24V	CM1aF-P-24V
1 Form C	12 V DC	CM1-12V	CM1F-12V	—	—
	24 V DC	CM1-24V	CM1F-24V	CM1-P-24V	CM1F-P-24V

Standard packing; Carton: 50 pcs.; Case: 200 pcs.

Note: Please use "CM**-R-**-*" built-in resistor type and "CA**-D-**-*" to order built-in diode type. (Asterisks "*" should be filled in from ORDERING INFORMATION.)

1. Coil data

Nominal coil voltage	Pick-up voltage (at 20°C 68°F)	Drop-out voltage (at 20°C 68°F)	Nominal operating current [±10%] (at 20°C 68°F)	Coil resistance [±10%] (at 20°C 68°F)	Nominal operating power	Usable voltage range
12 V DC	3 to 7 V DC	1.2 to 4.2 V DC	125 mA	96Ω	1.5 W	10 to 16V DC
24 V DC	6 to 14 V DC	2.4 to 8.4 V DC	75 mA	320Ω	1.8 W	20 to 32V DC

2. Specifications

Characteristics	Item	Specifications			
		12 V DC		24 V DC	
Contact	Arrangement	1 Form A	1 Form C	1 Form A	1 Form C
	Contact resistance (Initial)	Typ 2mΩ (By voltage drop 6V DC 1A)			
	Contact voltage drop (after electrical life test)	N.O.: Max. 0.5 V (By voltage drop 14 V DC 35 A)	N.O.: Max. 0.5 V (By voltage drop 14 V DC 35 A) N.C.: Max. 0.3 V (By voltage drop 14 V DC 20 A)	N.O.: Max. 0.3 V (By voltage drop 28 V DC 15 A)	N.O.: Max. 0.3 V (By voltage drop 28 V DC 15 A) N.C.: Max. 0.2 V (By voltage drop 28 V DC 8 A)
	Contact material	Ag alloy (Cadmium free)			
Rating	Nominal switching capacity (resistive load)	N.O.: 35 A 14V DC	N.O.: 35 A 14V DC N.C.: 20 A 14V DC	N.O.: 15 A 28V DC	N.O.: 15 A 28V DC N.C.: 8 A 28V DC
	Max. carrying current (at 85°C 185°F, continuous)	N.O.: 20 A 14V DC	N.O.: 20 A 14V DC N.C.: 10 A 14V DC	N.O.: 15 A 28V DC	N.O.: 15 A 28V DC N.C.: 8 A 28V DC
	Nominal operating power	1.5 W, 1.7 W (with resistor inside type)		1.8 W, 2.0 W (with resistor inside type)	
	Min. switching capacity (resistive load)*1	1 A 12V DC		1 A 24V DC	
Electrical characteristics	Insulation resistance (Initial)	Min. 20 MΩ (at 500V DC, Measurement at same location as "Breakdown voltage" section.)			
	Breakdown voltage (Initial)	Between open contacts	500 Vrms for 1 min. (Detection current: 10mA)		
		Between contacts and coil	500 Vrms for 1 min. (Detection current: 10mA)		
	Operate time (at nominal voltage) (at 20°C 68°F)	Max. 10ms (excluding contact bounce time) (Initial)			
Release time (at nominal voltage) (at 20°C 68°F)	Max. 10ms (excluding contact bounce time), Max. 15ms (with diode inside type, excluding contact bounce time) (Initial)				
Mechanical characteristics	Shock resistance	Functional	Min. 200 m/s ² {20G} (Half-wave pulse of sine wave: 11ms; detection time: 10μs)		
		Destructive	Min. 1,000 m/s ² {100G} (Half-wave pulse of sine wave: 6ms)		
	Vibration resistance	Functional	10 Hz to 500 Hz, Min. 44.1 m/s ² {4.5G}		
		Destructive	10 Hz to 2,000 Hz, Min. 44.1 m/s ² {4.5G}, Time of vibration for each direction; X, Y, Z direction: 4 hours		
Expected life	Mechanical (at 120 cpm)	Min. 10 ⁶			
	Electrical (operating frequency: 2s ON, 2s OFF)	Flux-resistant type: Min. 10 ⁵ , Sealed type: Min. 5 × 10 ⁴			
Conditions	Conditions for operation, transport and storage*2	Ambient temperature: -40°C to +85°C -40°F to +185°F*3, Humidity: 5% R.H. to 85% R.H. (Not freezing and condensing at low temperature), Air pressure: 86 to 106 kPa			
Mass		Approx. 20 g .71 oz			

Notes: *1. This value can change due to the switching frequency, environmental conditions, and desired reliability level, therefore it is recommended to check this with the actual load.

*2. The upper operation ambient temperature limit is the maximum temperature that can satisfy the coil temperature rise value. Please refer to "Usage ambient condition" in CAUTIONS FOR USE OF AUTOMOTIVE RELAYS.

*3. Please inquire if you will be using the relay in a high temperature atmosphere.

REFERENCE DATA

1-(1). Coil temperature rise (12V type)

Sample: CM1F-12V, 3 pcs.
Measured portion: Inside the coil
Contact carrying current: 20A, 35A
Ambient temperature: 85°C 185°F

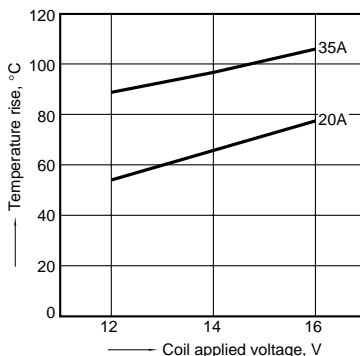

1-(2). Coil temperature rise (24V type)

Sample: CM1F-24V, 4 pcs.
Measured portion: Inside the coil
Contact carrying current: 0A, 15A
Ambient temperature: 85°C 185°F

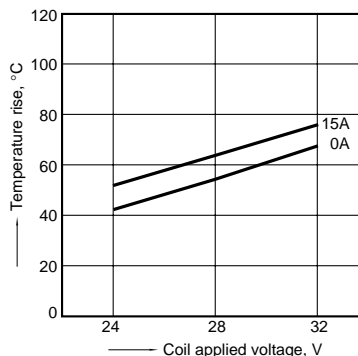

2. Max. switching capability (Resistive load, initial)

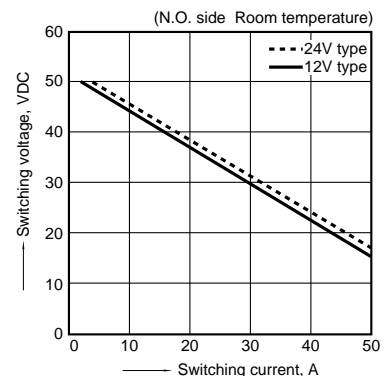

3. Ambient temperature and operating voltage range (12V type)

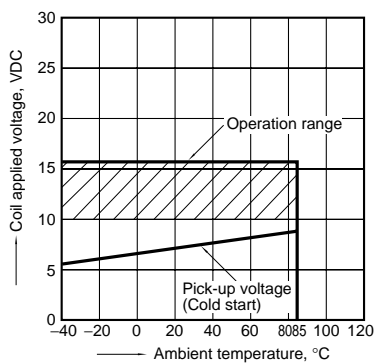

4. Ambient temperature characteristics (Cold/initial)

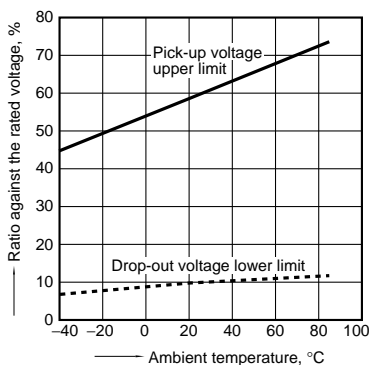

5. Distribution of pick-up and drop-out voltage
Sample: CM1F-12V, 100pcs.

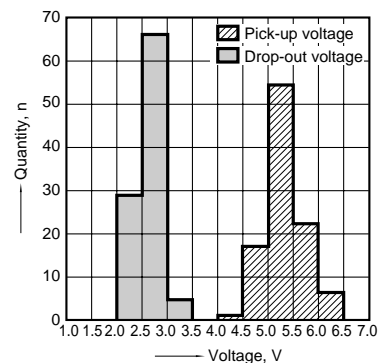

6. Distribution of operate time

Sample: CM1F-12V, 30pcs.

* Max. 10ms standard (excluding contact bounce)

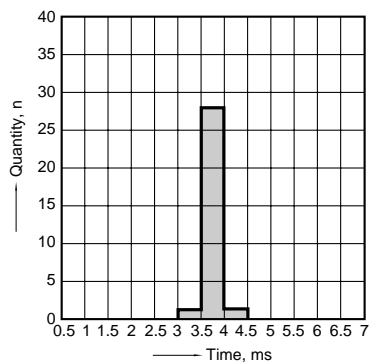

7. Distribution of release time

Sample: CM1F-12V, 30pcs.

* Max. 10ms standard (excluding contact bounce)
Without diode

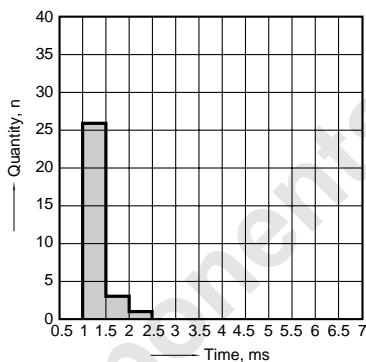

8-(1). Electrical life test (Motor free)

Sample: CM1aF-R-12V, 6pcs.

Load: 16 A 13.5 V DC

Cooling fan motor actual load (free condition)

Operating frequency: ON 2s, OFF 6s

Ambient temperature: Room temperature

Circuit

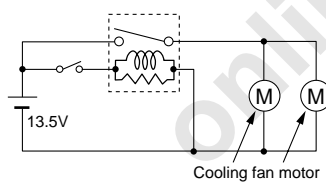

Change of pick-up and drop-out voltage

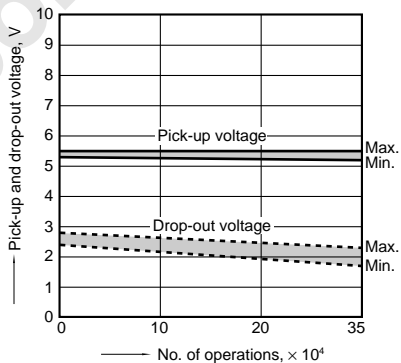

Change of contact resistance

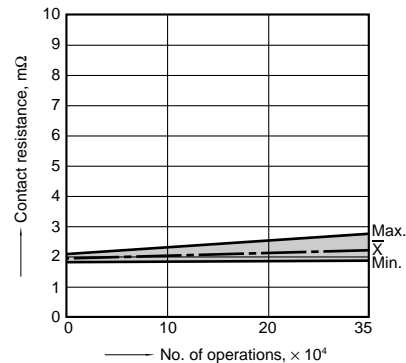

Load current waveform

Inrush current: 85A, Steady current: 18A,

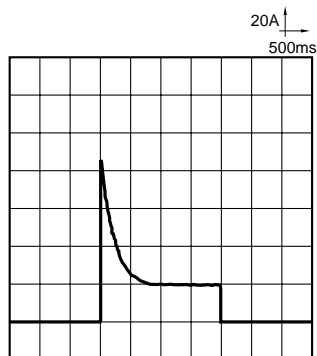

8-(2). Electrical life test (Halogen lamp load)
 Sample: CM1aF-R-12V, 6pcs.
 Load: 20A 13.5V DC
 Operating frequency: ON 1s, OFF 14s
 Ambient temperature: Room temperature

Change of pick-up and drop-out voltage

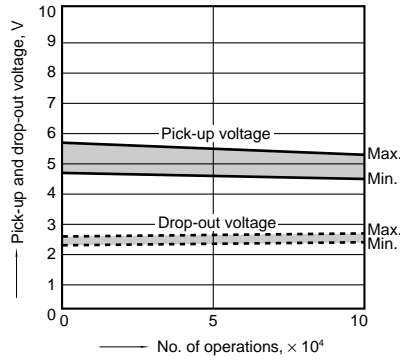

Change of contact resistance

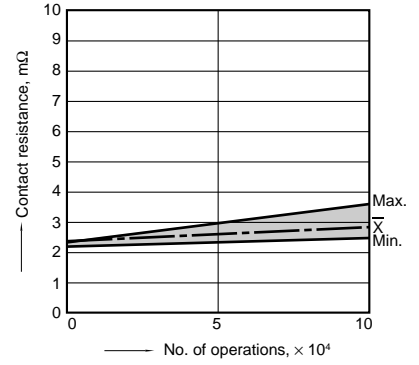

DIMENSIONS (mm inch)

The CAD data of the products with a **CAD Data** mark can be downloaded from: <http://panasonic-electric-works.net/ac>

1. Micro-ISO Plug-in type (1 Form C)

CAD Data

External dimensions

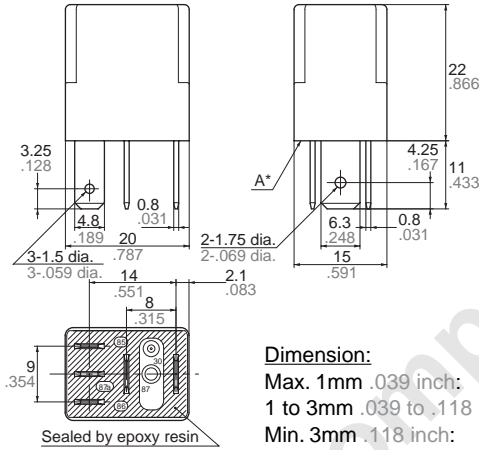

Dimension:	General tolerance
Max. 1mm .039 inch:	±0.1 ±.004
1 to 3mm .039 to .118 inch:	±0.2 ±.008
Min. 3mm .118 inch:	±0.3 ±.012

Schematic (Bottom view)

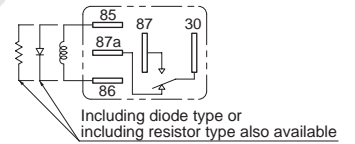

* Intervals between terminals is measured at A surface level.

2. Micro-ISO Plug-in type (1 Form A)

CAD Data

External dimensions

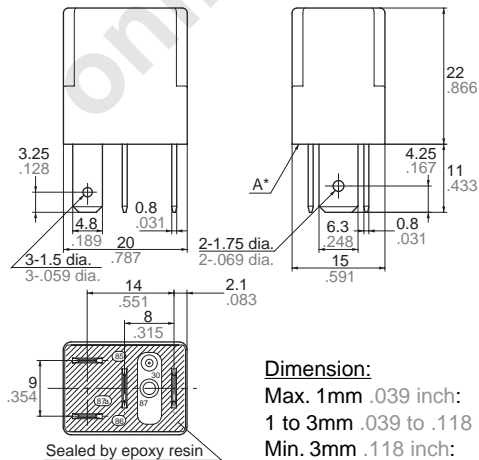

Dimension:	General tolerance
Max. 1mm .039 inch:	±0.1 ±.004
1 to 3mm .039 to .118 inch:	±0.2 ±.008
Min. 3mm .118 inch:	±0.3 ±.012

Schematic (Bottom view)

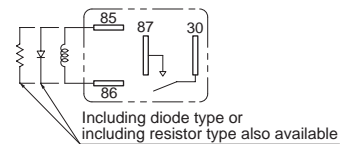

* Intervals between terminals is measured at A surface level.

3. Micro-ISO PC board type (1 Form C)

CAD Data

External dimensions

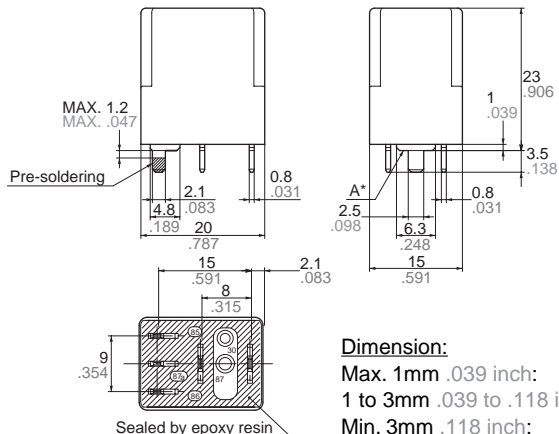

Dimension:
 Max. 1mm .039 inch: $\pm 0.1 \pm .004$
 1 to 3mm .039 to .118 inch: $\pm 0.2 \pm .008$
 Min. 3mm .118 inch: $\pm 0.3 \pm .012$

Schematic (Bottom view)

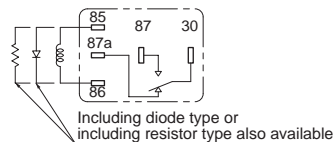

PC board pattern (Bottom view)

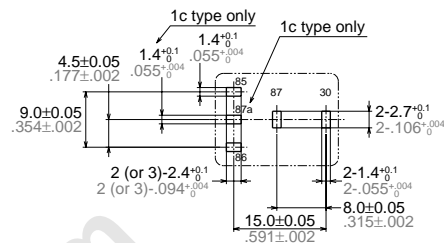

* Dimensions (thickness and width) of terminal is measured before pre-soldering.
 Intervals between terminals is measured at A surface level.

4. Micro-ISO PC board type (1 Form A)

CAD Data

External dimensions

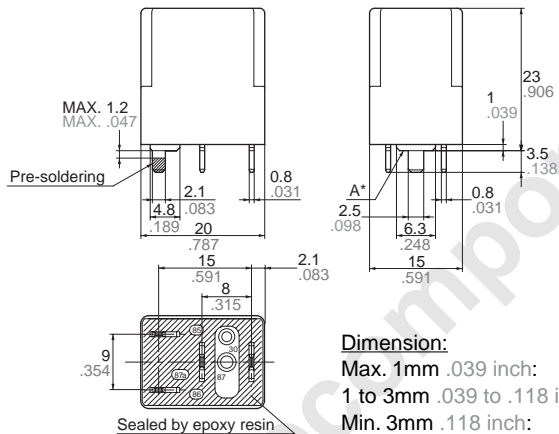

Dimension:
 Max. 1mm .039 inch: $\pm 0.1 \pm .004$
 1 to 3mm .039 to .118 inch: $\pm 0.2 \pm .008$
 Min. 3mm .118 inch: $\pm 0.3 \pm .012$

Schematic (Bottom view)

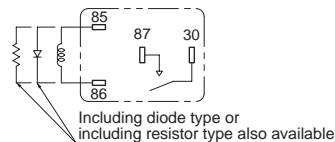

* Dimensions (thickness and width) of terminal is measured before pre-soldering.
 Intervals between terminals is measured at A surface level.

For Cautions for Use, see Relay Technical Information.